

A 700V, 1us pulse from model AVR-7B-B

The AVR-5B, AVR-7B, and AVR-8A series of pulse generators are fast high-voltage pulse generators capable of driving load impedances of 50Ω and higher. (Lower impedance loads are also acceptable if the maximum current rating is respected). These easy-to-use models are suitable for many different test applications, including resistor and attenuator testing, semiconductor and laser diode characterization, time-of-flight applications, and many other applications.

Model AVR-5B-B provides up to 500V / 10A with rise times of 20 ns and pulse widths variable from 100 ns to 100 us. The pulse repetition frequency (or “PRF”) is variable from 1 Hz to 10 kHz. This model will provide peak output power of 5000 Watts and average outputs of 50 Watts (optionally 100 or 200 Watts). The standard output connector is N-type.

Model AVR-7B-B is similar, but provides up to 700V / 14A. This model will provide peak output power of 10000 Watts and average outputs of 50 Watts (optionally 80 or 160 Watts).

The AVR-8A-B provides up to 1000V / 20A with rise times of 50 ns and pulse widths variable from 200 ns to 200 us. PRF is variable from 1 Hz to 1 kHz. This model will provide peak output power of 20000 Watts and average outputs of 40 Watts (optionally 100 or 200 Watts). The standard output connector is SHV-type.

The output stages in all models will safely withstand any combination of front panel control settings, output open or short circuits, and high-duty cycles. An internal power supply monitor removes the power to the output stage for several seconds if an average power overload exists. The peak instantaneous currents are also actively limited to protect the output.

Aside from the internal clock, all models can also be triggered by a single-pulse pushbutton or an external TTL-level trigger input. When triggered externally, the output pulse width can be set to track the input trigger pulse width ($PW_{OUT} = PW_{IN}$). A delay control and a sync output are provided for oscilloscope triggering. A gate input is also provided. Either output polarity can be provided, as well as a dual output polarity option.

- ◆ Amplitudes to 500, 700, or 1000 Volts
- ◆ Peak powers of up to 20 kilowatts
- ◆ Average powers of up to 200 Watts
- ◆ 20 or 50 ns rise and fall times
- ◆ Pulse widths variable from 0.1-100 us, or 0.2-200 us
- ◆ PRF to 1 kHz or 10 kHz
- ◆ For time-of-flight and many other applications
- ◆ IEEE-488.2 GPIB and RS-232 interfaces
- ◆ Optional ethernet port for VXI-11.3 support

All models include a computer control interface (see <http://www.avtechpulse.com/gpib> for details). This provides GPIB and RS-232 computer-control, as well as front panel keypad and adjust knob control of the output pulse parameters. A large back-lit LCD displays the output amplitude, polarity, frequency, pulse width, and delay. To allow easy integration into automated test systems, the programming command set is based on the SCPI standard, and LabView drivers are available for download at <http://www.avtechpulse.com/labview>.

The -VXI option adds a rear-panel Ethernet connector, allowing an instrument to be remotely controlled using the VXI-11.3, ssh, telnet, and web protocols. In particular, the VXI-11.3 features allows software like LabView to control an instrument using standard VISA communications drivers and network cabling, instead of using older-style GPIB cabling and GPIB controller cards. See <http://www.avtechpulse.com/options/vxi>.

All models are available with optional electronic analog control of the amplitude (the “-EA” option). With this feature, the output amplitude may be controlled by an externally applied analog DC voltage (0 to +10 V), in addition to the standard front panel and computer control methods.

The amplitude is controlled by internal high-voltage DC power supplies. Standard models use a simple low-power discharge circuit to reduce the amplitude when settings are lowered. A higher-power / higher-speed active-discharge circuit is available as an option (-QD option), which reduces the discharge times significantly. This option is recommended for high-throughput production-line test applications.

The standard output connectors may optionally be changed from N (on the AVR-5 and AVR-7 series) or SHV (AVR-8) to SHV, MHV or HN by adding “-SHV”, “-MHV”, or “-HN” to the model number. All models require 100 - 240 V, 50 - 60 Hz, and are mounted in a rugged all-metal 3.9” x 17” x 14.8” chassis.

A burst mode option is also available, allowing a burst of 1-500 pulses to be generated in response to a single trigger event (<http://www.avtechpulse.com/options/br>).

The maximum pulse widths and duty cycles of these instruments may be extended if the intended load is high-impedance (i.e., much greater than 50Ω, such as a plate load). Contact the factory with your special requirements. A parametric search engine is available online at <http://www.avtechpulse.com/pick> to assist you in selecting the best instrument for your application.

Models in the AVR series may be suitable for replacing obsolete models from the former Velonex Corporation in many applications.

For applications requiring high-voltage pulses with faster rise times, see the AVRZ-5 series (datasheets & pricing

are available at <http://www.avtechpulse.com/speed>), which offers 0 to 500V pulses with 9 ns rise times, and pulse widths as low as 15 ns or as high as 10 us.

See also the AVRF Series (datasheets and pricing at <http://www.avtechpulse.com/medium/avr-7a>) for 600 Volt and 750 Volt units with 6 and 7.5 ns rise times.

Actual test waveforms from shipped units are available from the online data pages for each model, at:

- <http://www.avtechpulse.com/medium/avr-5b/#testresults>
- <http://www.avtechpulse.com/medium/avr-7b/#testresults>
- <http://www.avtechpulse.com/medium/avr-8a/#testresults>



AVR-5B-B

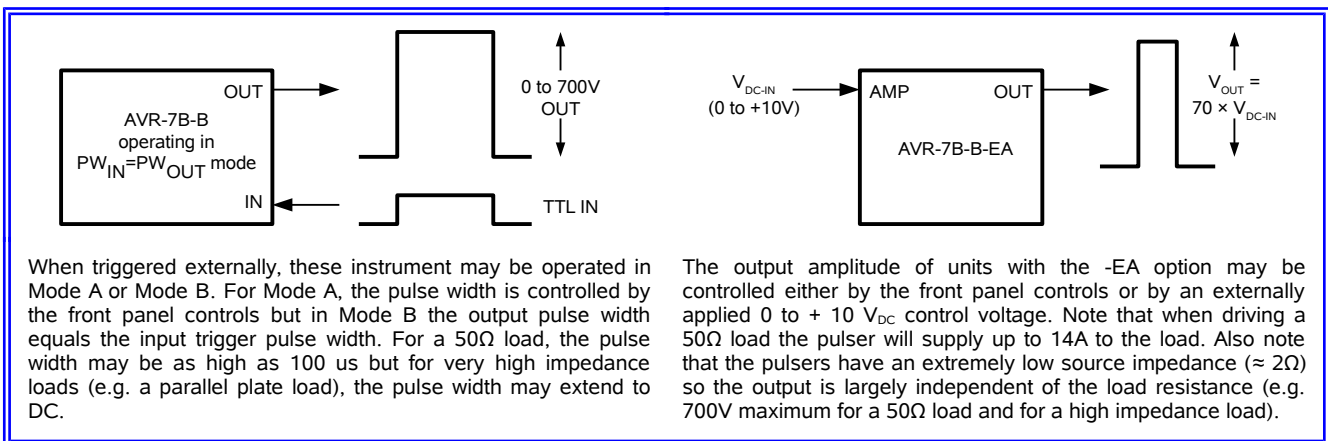

Use the “Pick the Perfect Pulser” parametric search engine
at <http://www.avtechpulse.com/pick>
to find the best pulser for your application!



SPECIFICATIONS

AVR-5B,-7B,-8A SERIES

Model ¹ :	AVR-5B-B	AVR-7B-B	AVR-8A-B
Amplitude into 50Ω ^{2,3,16} :	< 20 to 500 Volts	< 25 to 700 Volts	< 25 to 1000 Volts
Maximum output current:	10 Amps	14 Amps	20 Amps
Output impedance:	< 2Ω		
Rise & fall times (20%-80%) into 50Ω:	≤ 20 ns		≤ 50 ns
Pulse width (FWHM) ⁴ :	100 ns to 100 us		200 ns to 200 us
PRF: external trigger mode:	0 to 10 kHz		0 to 1 kHz
internal trigger:	1 Hz to 10 kHz		1 Hz to 1 kHz
Maximum duty cycle and maximum average output power:	Standard: 1%, 50W With -XP1 option: 2%, 100W With -XP2 option: 4%, 200W	Standard: 0.5%, 50W With -XP1 option: 0.8%, 80W With -XP2 option: 1.6%, 160W	Standard: 0.2%, 40W With -XP1 option: 0.5%, 100W With -XP2 option: 1%, 200W
Maximum droop at maximum pulse width, into 50Ω ¹⁵ :	4%		6%
Amplitude discharge time constant, τ _{DIS} (typical) ¹² :	2 seconds	Standard: 16 seconds With -QD option: 1 second	Standard: 30 seconds With -QD option: 1 second
Minimum time between full discharges of the HV PS ¹³ :	10 seconds	Standard: > 5 τ _{DIS} With -QD option: 10 seconds	
Amplitude charge-up time ¹⁴ :	< 8 seconds		
Polarity ⁵ :	Positive or negative or both (specify -P, -N, or -PN). Dual polarity not available with -XP2 option.		
GPIB and RS-232 control ² :	Standard on -B units. See http://www.avtechpulse.com/gpib for more information.		
LabView Drivers:	Available at http://www.avtechpulse.com/labview .		
Ethernet port, for remote control using VXI-11.3, ssh, telnet, web:	Optional ⁶ . Recommended as a modern alternative to GPIB / RS-232. See http://www.avtechpulse.com/options/vxi for details.		
Settings resolution:	The resolution of the timing parameters (pulse width, delay, period) varies, but is always better than 0.15% of ([set value] + 20 ns). The amplitude resolution is < 0.1% of the maximum amplitude.		
Settings accuracy (into 50Ω):	Typically ± 3% (plus ±1V or ± 2 ns) after 10 minute warmup. For high-accuracy applications requiring traceable calibration, verify the output parameters with a calibrated oscilloscope.		
Burst mode:	Optional ¹¹ . Generates 1-500 pulses per trigger event. See http://www.avtechpulse.com/options/br .		
Propagation delay:	≤ 200 ns (Ext trig in to pulse out)		
Jitter (Ext trig in to pulse out):	± 100 ps ± 0.03% of sync delay		
Trigger modes:	Internal trigger, external trigger (TTL level pulse, > 10 ns, 1 kΩ input impedance), front-panel "Single Pulse" pushbutton, or single pulse trigger via computer command. In the external trigger mode, the pulse width may be set by the instrument, or it may be set to track the input pulse width.		
Variable delay:	Sync to main out: 0 to 1.0 seconds, for all trigger modes (including external trigger).		
Sync output:	> +3 Volts, > 50 ns, will drive 50 Ohm loads		
Gated operation:	Synchronous or asynchronous, active high or low, switchable. Suppresses triggering when active.		
Connectors:	OUT: N ^{7,8} Trig, Sync, Gate: BNC	OUT: SHV ^{9,10} Trig, Sync, Gate: BNC	
Power requirements:	100 - 240 Volts, 50 - 60 Hz		
Dimensions (H x W x D):	100 mm x 430 mm x 375 mm (3.9" x 17" x 14.8")		
Chassis material:	cast aluminum frame and handles, blue vinyl on aluminum cover plates		
Temperature range:	+5°C to +40°C		

- 1) -B suffix indicates GPIB-equipped model.
- 2) For analog electronic control (0 to +10V) of amplitude, add the suffix -EA to the model number. Electronic control units also include the standard front panel controls.
- 3) For operation at amplitudes of less than 10% of full-scale, best results will be obtained by setting the amplitude near full-scale and using external attenuators on the output.
- 4) The output pulse width may also be controlled externally by applying a TTL-level trigger of the desired width to a rear-panel BNC connector (PW_{IN} = PW_{OUT} mode).
- 5) Indicate desired polarity by suffixing the model number with -P or -N (i.e. positive or negative) or -PN for dual polarity option.
- 6) Add the suffix -VXI to the model number to specify the Ethernet port.
- 7) SHV, MHV or HN output connectors can also be provided. To specify, suffix the model number with -SHV, -MHV or -HN as required.
- 8) An N-male to BNC-female adapter (Amphenol P/N 31-216) is available. Add the suffix -ADPT2 to the model number to order this adapter.
- 9) An adapter kit, consisting of an SHV PLUG to MHV FEMALE adapter and an MHV MALE to BNC FEMALE adapter, is available. Add the suffix -ADPT1 to the model number to order this kit.

- 10) MHV, N or HN output connectors can also be provided. To specify, suffix the model number with -MHV, -NC or -HN as required.
- 11) Add the suffix -BR to the model number to specify the burst mode option. See <http://www.avtechpulse.com/options/br> for details about this option.
- 12) The output amplitude is controlled by internal high-voltage DC power supplies. When the amplitude setting is reduced, the high voltage decays in an exponential fashion, with the typical time constant noted in this specification. The -QD option provides a fast active-discharge circuit.
- 13) More frequent discharges will cause the instrument to overheat, and may cause damage.
- 14) The output amplitude is controlled by internal high-voltage DC power supplies. This is the time required for the power supplies to rise from 5% to 95% of their full value in response to a change in settings from zero to the maximum setting.
- 15) Valid for 50 Ohm loads. The droop will be proportionally higher into lower resistance loads.
- 16) The instrument may be used to drive resistive loads of less than 50 Ohms, as long as the maximum output current specification is not exceeded. The rise and fall times may increase.