

PULSE GENERATOR  
PERFORMANCE CHECK

Model: *APR-AP-HV3-C-US1-P*  
S.N.: *3956*  
Date: *AUG 27 87*

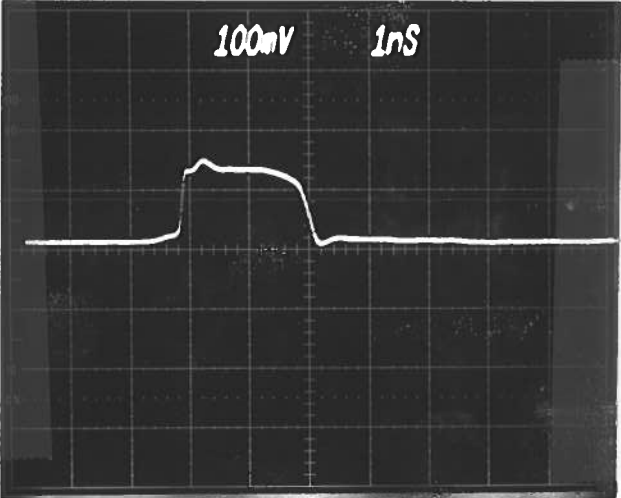

*32 VOLT/DIV*  
*1.0 NSEC/DIV*  
*1.0 MHz*

- a) Output signal amplitude:  
*0 TO +40 VOLTS*
- b) Pulse width:  
*0.4 TO 2.0 NSEC*
- c) Rise time:  
*≤ 150 PSEC*
- d) Fall time:  
*≤ 250 PSEC*
- e) PRF:  
*0.7/1.0 MHz*
- f) Jitter, stability:  
*OK*
- g) Prime power:  
*120/240 V*  
*50-60 Hz*

# AN INTRODUCTION TO AVTECH NANOSECOND WAVEFORM GENERATORS

Most Avtech models are available in either of the following three formats:

- Stand alone lab instrument including internal clock and line powering (110/220 volts, 50-60 Hz, with detachable line cord). See Fig. 1. Standard controls generally include pulse width, amplitude, pulse repetition frequency, delay (0 to 200 nsec for sampling scope triggering) and sync output. Units may also be triggered externally using a slow speed TTL signal. To specify suffix model number by -C.
- Line powered chassis (110/220 volts, 50-60 Hz, with detachable line cord) requiring external slow speed TTL

trigger signal. See Fig. 2. Output PRF equals input trigger PRF. Standard controls generally include pulse width and amplitude. To specify suffix model number by -PS.

- DC powered miniature module (either +15 or +24V) requiring external slow speed TTL trigger signal. See Fig. 3. Output PRF equals the input trigger PRF. Standard controls generally include output pulse width and amplitude. No suffix needed to specify.

See the drawing below for typical instrument block diagrams and page 12 for typical chassis photographs of the three formats.

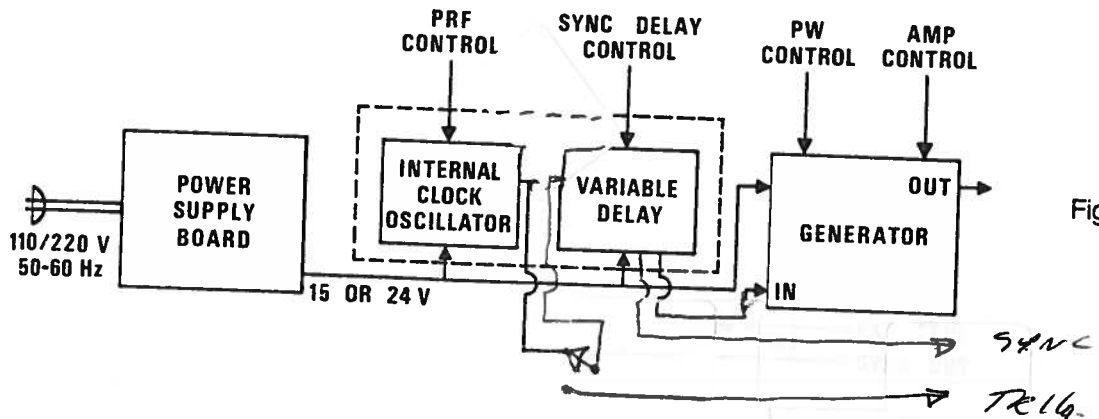

Fig. 1 C Format

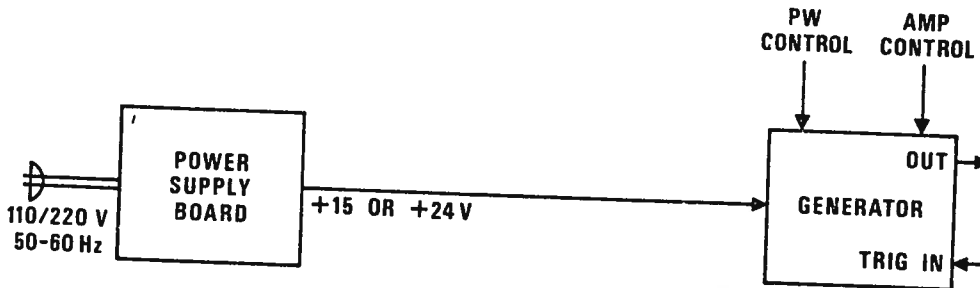

Fig. 2 PS Format

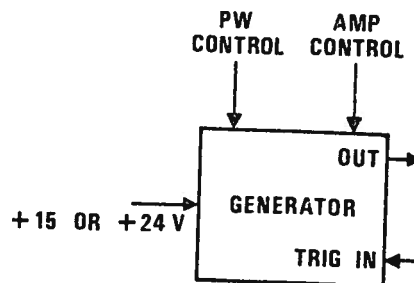

Fig. 3 Module Format

Avtech waveform generators combine aspects of micro-wave integrated circuit technology with ultra-fast semiconductor device switching technology (including SRD, hot carrier diodes, avalanche, VMOS and bipolar transistor switches) to yield 100 psec rise and fall times, PRF beyond 250 MHz, amplitudes to 350 volts, peak currents to 100 Amps and single cycles of RF to 1500 MHz. Avtech continues to redefine the state-of-the-art of fast waveform

technology for optical communications, GHz logic, laser, SAW, radar, device switching, nuclear and TDR applications including both laboratory and OEM aspects.

All units are produced using top quality components and methods and at least 90% of the components are supplied by U.S. manufacturers.