



AVTECH ELECTROSYSTEMS LTD.

NANOSECOND WAVEFORM ELECTRONICS
SINCE 1975

P.O. BOX 265
OGDENSBURG, NY
U.S.A. 13669-0265
TEL: (315) 472-5270
FAX: (613) 226-2802

TEL: 1-800-265-6681
FAX: 1-800-561-1970

e-mail: info@avtechpulse.com
<http://www.avtechpulse.com/>

BOX 5120, LCD MERIVALE
OTTAWA, ONTARIO
CANADA K2C 3H4
TEL: (613) 226-5772
FAX: (613) 226-2802

INSTRUCTIONS

MODEL AV-1011-C-MSHA

0 TO ± 100 VOLTS, 2 AMP,

10 ns RISE & FALL TIME

LAB PULSE GENERATOR AND LASER DIODE DRIVER

SERIAL NUMBER: _____

WARRANTY

Avtech Electrosystems Ltd. warrants products of its manufacture to be free from defects in material and workmanship under conditions of normal use. If, within one year after delivery to the original owner, and after prepaid return by the original owner, this Avtech product is found to be defective, Avtech shall at its option repair or replace said defective item. This warranty does not apply to units which have been disassembled, modified or subjected to conditions exceeding the applicable specifications or ratings. This warranty is the extent of the obligation assumed by Avtech with respect to this product and no other warranty or guarantee is either expressed or implied.

TECHNICAL SUPPORT

Phone: 613-226-5772 or 1-800-265-6681

Fax: 613-226-2802 or 1-800-561-1970

E-mail: info@avtechpulse.com

World Wide Web: <http://www.avtechpulse.com>

TABLE OF CONTENTS

WARRANTY.....	2
TECHNICAL SUPPORT.....	2
TABLE OF CONTENTS.....	3
INTRODUCTION.....	4
-MSHA Option.....	4
SPECIFICATIONS.....	5
INSTALLATION.....	6
VISUAL CHECK.....	6
PLUGGING IN THE INSTRUMENT.....	6
FRONT PANEL CONTROLS.....	8
REAR PANEL CONTROLS.....	11
GENERAL INFORMATION.....	12
BASIC TEST ARRANGEMENT.....	12
BASIC PULSE CONTROL.....	12
MINIMIZING WAVEFORM DISTORTIONS.....	14
OUTPUT IMPEDANCE.....	14
GENERATING LOW-VOLTAGE WAVEFORMS.....	14
USE 50Ω TRANSMISSION LINES.....	14
USE LOW-INDUCTANCE LOADS.....	14
OPERATIONAL CHECK.....	16
MECHANICAL INFORMATION.....	18
TOP COVER REMOVAL.....	18
RACK MOUNTING.....	18
ELECTROMAGNETIC INTERFERENCE.....	18
MAINTENANCE.....	19
REGULAR MAINTENANCE.....	19
CLEANING.....	19
PERFORMANCE CHECK SHEET.....	20

INTRODUCTION

The AV-1011-C-MSHA is a high performance instrument capable generating amplitudes up to ± 100 V into 50Ω at repetition rates up to 1 MHz. Pulse widths are variable up to 1 ms. Rise and fall times are fixed at less than 10 ns. The AV-1011-C-MSHA provides single or double pulse output and can be triggered or gated by an external source. A front-panel pushbutton can also be used to trigger the instrument. The output pulse width can be set to follow an input trigger pulse width and the output amplitude can be controlled by an externally applied 0 to +10 Volts DC control voltage.

The output impedance depends on the amplitude range selected. For the ± 100 V ranges, the output impedance is approximately 2Ω . In the lower ranges (± 50 V and below), the output impedance is 50Ω .

The MOSFET output stages will safely withstand any combination of front panel control settings, output open or short circuits, and high duty cycles. An internal power supply monitor removes the power to the output stage for five seconds if an average power overload exists. After that time, the unit operates normally for one second, and if the overload condition persists, the power is cut again. This cycle repeats until the overload is removed. With a 50Ω load the unit will withstand duty cycles as high as 10%. The output stage will source up to 2.5 Amps (and will automatically shut down if the load current exceeds 2.5 Amps).

Application notes describing the use of the AV-1010 and AV-1011 families of pulse generators are available on the Avtech web site, <http://www.avtechpulse.com>. In particular, application notes describing techniques for driving laser diodes, and for using pulse transformers to boost the output current, are presented.

This instrument is intended for use in research and development laboratories.

-MSHA Option

The -MSHA option lowers the minimum pulse width rating of the standard AV-1011-C from 100 ns to 50 ns.

SPECIFICATIONS

Model:	AV-1011-C-MSHA
Rise time, fall time:	≤ 10 ns
Pulse output amplitude ¹ : (R _L = 50 Ohms)	0 to 100 Volts (for Z _{out} = 2Ω) 0 to 50 Volts (for Z _{out} = 50Ω)
Pulse width ² :	50 ns to 1 ms
Pulse repetition rate:	100 Hz to 1.0 MHz
Maximum duty cycle:	10% into 50Ω loads, 80% into >10kΩ loads
Output impedance:	±1.5,5,15,50V ranges: 50Ω ±100V ranges: 2Ω
Required load impedance:	≥ 50 Ω
Output polarity:	Positive or negative, switchable
Jitter:	Pulse width: ≤ 0.1 %, (typically ≤ 0.01 %), Delay/Advance, Period: ≤ 0.1%, + 0.5 ns
Pulse aberrations:	≤ ± 0.5V ± 5 % of amplitude
Double pulse spacing:	100 ns to 1 ms
Sync to main-output delay:	± 100 ns to ± 1 ms
Sync output:	+ 3 Volts, 50 ns (R _L ≥ 1 kΩ)
Gated operation:	triggering stops when gate is TTL-low (0V)
External trigger:	May be triggered by a signal with Amp: +3 to +5V, Rep. Rate: ≤ 1 MHz, Pulse width: ≥ 50 ns
Minimum propagation delay, external trigger modes:	Advance: 200 ns Double pulse: 200 ns Delay: 300 ns PW _{IN} = PW _{OUT} : 100 ns
Output protection:	The output is protected against short circuits, open circuits, and high duty cycle
Connectors:	BNC female
Power source:	120/240 Volts, ± 10 % (switchable), 48 Hz to 66 Hz
Dimensions (H x W x D):	100 mm x 430 mm x 375 mm (3.9" x 17" x 14.8")
Chassis material, Weight:	Anodized aluminum with blue-gray plastic trim. ≤ 10 kg (22 lbs).
Operating temperature:	+5°C to +40°C
Optional rack-mount kit:	Add "-R5" to model number to include 19" rack mount kit

1) The output amplitude may also be controlled by applying 0 to +10 V DC to a rear-panel BNC connector.

2) The output pulse width may also be controlled externally by applying a TTL-level trigger of the desired width to a rear-panel BNC connector (PW_{IN} = PW_{OUT} mode).

INSTALLATION

VISUAL CHECK

After unpacking the instrument, examine to ensure that it has not been damaged in shipment. Visually inspect all connectors, knobs, and handles. Confirm that a power cord is with the instrument. If the instrument has been damaged, file a claim immediately with the company that transported the instrument.

PLUGGING IN THE INSTRUMENT

Examine the rear of the instrument. There will be a male power receptacle, a fuse holder and the edge of the power selector card visible. Confirm that the power selector card is in the correct orientation.

For AC line voltages of 110-120V, the power selector card should be installed so that the “120” marking is visible from the rear of the instrument, as shown below:



For AC line voltages of 220-240V, the power selector card should be installed so that the “240” marking is visible from the rear of the instrument, as shown below:



If it is not set for the proper voltage, remove the fuse and then grasp the card with a pair of pliers and remove it. Rotate horizontally through 180 degrees. Reinstall the card and the correct fuse.

In the 120V setting, a 1.0A slow blow fuse is required. In the 240V setting, a 0.5A slow blow fuse is required.

FRONT PANEL CONTROLS

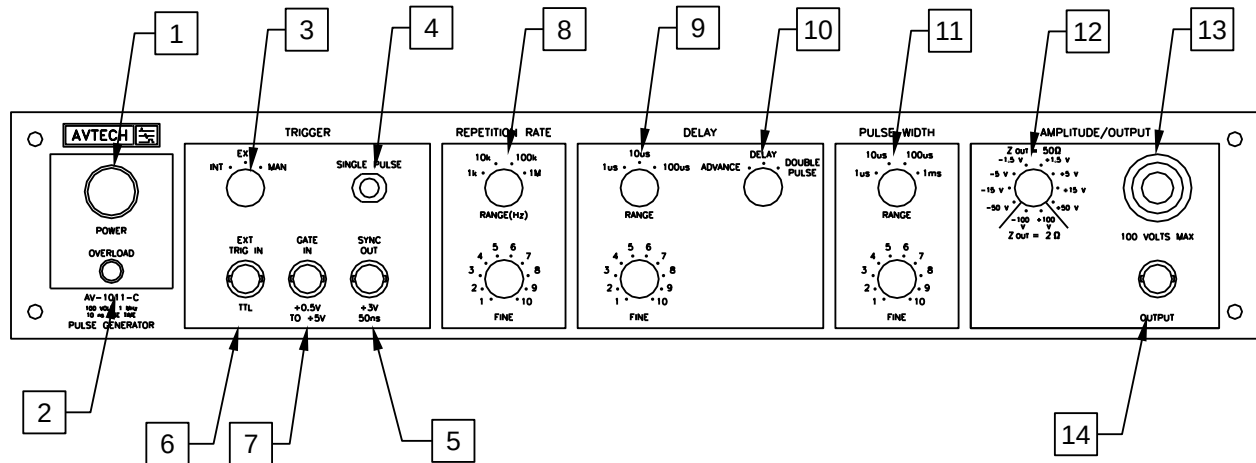

- 1) POWER Switch. This is the main power switch. When turning the instrument on, there may be a delay of several seconds before the instrument appears to respond.
- 2) OVERLOAD Indicator. An automatic overload protective circuit controls the front panel overload light. If the unit is overloaded (by operating at an exceedingly high duty cycle or by operating into a very low impedance), the protective circuit will turn the output of the instrument OFF and turn the indicator light ON. The light will stay ON (i.e. output OFF) for about 5 seconds after which the instrument will attempt to turn ON (i.e. light OFF) for about 1 second. If the overload condition persists, the instrument will turn OFF again (i.e. light ON) for another 5 seconds. If the overload condition has been removed, the instrument will turn on and resume normal operation. Overload conditions may be removed by:
 - a) Reducing PRF (i.e. switch to a lower range)
 - b) Reducing pulse width (i.e. switch to a lower range)
 - c) Removing output low load impedance (if any)
 - d) Reducing the output amplitude (i.e. switch to a lower range)
- 3) INT/EXT Switch. This switch sets the triggering mode for the instrument. When set to the "EXT" position, the instrument is triggered by externally-generated TTL-level (0 and 3-5V logic levels) pulses on the "EXT TRIG" input connector, or by pressing the "SINGLE PULSE" push-button. When set to the "INT" position, the instrument is triggered by the internal oscillator, whose frequency is controlled by the "REPETITION RATE" controls.
- 4) SINGLE PULSE Push Button. The "SINGLE PULSE" push button will trigger the instrument manually for one cycle of output, when the "INT/EXT" switch is in the "EXT" position. Otherwise, the push button has no effect.

- 5) SYNC OUT. When the "INT/EXT" switch is in the "INT" position, this connector supplies a SYNC output that can be used to trigger other equipment, particularly oscilloscopes. This signal leads, or lags, the main output by a duration set by the "DELAY" controls and has an approximate amplitude of +3 Volts to $R_L > 1 \text{ k}\Omega$ with a pulse width of approximately 50 ns.
- 6) TRIG IN. When the "INT/EXT" switch is in the "EXT" position, the external trigger (standard TTL logic levels of 0 and +3 to +5 Volts, pulse width $>50 \text{ ns}$) is applied to this connector. This input presents a high impedance ($> 10 \text{ k}\Omega$). Depending on the length of cable attached to this input, and the source driving it, it may be desirable to add a coaxial 50 Ohm terminator to this input to provide a proper transmission line termination. The Pasternack (www.pasternack.com) PE6008-50 BNC feed-thru 50 Ohm terminator is suggested for this purpose.
- 7) GATE Input. The GATE input will suppress the triggering of the instrument if taken to a TTL LOW level (i.e. 0V). If it is left open or taken to a TTL HIGH (i.e., between 3V and 5V), normal triggering will occur. ($R_{IN} > 1 \text{ k}\Omega$).
- 8) REPETITION RATE Controls. The rotary switch marked "RANGE" selects the pulse repetition rate for the internally triggered mode. The vernier (labelled "MIN- MAX") provides continuously variable control of each range. There are six ranges and the instrument is set to the rate indicated on the front panel when the vernier is in the "MAX" position. The ranges are:

100 Hz - 1 kHz
 1 kHz - 10 kHz
 10 kHz - 100 kHz
 100 kHz - 1.0 MHz

- 9) DELAY Controls. The rotary switch selects one of six ranges and the vernier provides continuously variable control of each range. The instrument is set to the delay indicated on the front panel when the vernier is in the "MAX" position. The six ranges are:

100 ns - 1 us
 1 us - 10 us
 10 us - 100 us

- 10) ADVANCE, DELAY, DOUBLE PULSE. With this three-position switch in the ADVANCE position, the leading edge of the output pulse precedes the leading edge of the SYNC output. When in the DELAY position, the leading edge of the SYNC output precedes the leading edge of the main output. When in the DOUBLE PULSE position, the main output provides two successive output pulses having a separation determined by the DELAY controls.

- 11) PULSE WIDTH Controls. The rotary switch selects one of six ranges and the vernier provides continuously variable control of each range. The instrument is set to the pulse width indicated on the front panel when the vernier is in the "MAX" position.

The six ranges are:

50 ns - 1 us
 1 us - 10 us
 10 us - 100 us
 100 us - 1 ms

12) AMPLITUDE RANGE Switch. The rotary switch selects one of ten ranges and the vernier provides continuously variable control of each range. The instrument is set to the amplitude indicated on the front panel when the vernier is in the "MAX" position. The range setting also affects the output impedance. The output impedance is nominally 2 Ohms in the highest ranges, and 50 Ohms in the lower ranges. The ten ranges are:

0 to -100 Volts ($Z_{OUT} = 2 \text{ Ohm}$)
 0 to -50 Volts ($Z_{OUT} = 50 \text{ Ohm}$)
 0 to -15 Volts ($Z_{OUT} = 50 \text{ Ohm}$)
 0 to -5 Volts ($Z_{OUT} = 50 \text{ Ohm}$)
 0 to -1.5 Volt ($Z_{OUT} = 50 \text{ Ohm}$)
 0 to +1.5 Volts ($Z_{OUT} = 50 \text{ Ohm}$)
 0 to +5 Volt ($Z_{OUT} = 50 \text{ Ohm}$)
 0 to +15 Volts ($Z_{OUT} = 50 \text{ Ohm}$)
 0 to +50 Volts ($Z_{OUT} = 50 \text{ Ohm}$)
 0 to +100 Volts ($Z_{OUT} = 2 \text{ Ohm}$)

13) AMPLITUDE FINE. The ten-turn amplitude vernier provides continuously variable control of the peak amplitude of the main output from 0 Volts to the maximum set by the range switch.

14) OUT. BNC connector provides output to load impedance of 50 Ohms or higher.

⚠ Caution: Voltages as high as $\pm 100\text{V}$ may be present on the center conductor of this output connector. Avoid touching this conductor. Connect to this connector using standard coaxial cable, to ensure that the center conductor is not exposed.

REAR PANEL CONTROLS



1. **AC POWER INPUT.** A three-pronged recessed male connector is provided on the back panel for AC power connection to the instrument. Also contained in this assembly is a slow blow fuse and a removable card that can be removed and repositioned to switch between 120V AC in and 240V AC in.

For AC line voltages of 110-120V, the power selector card should be installed so that the “120” marking is visible from the rear of the instrument.

For AC line voltages of 220-240V, the power selector card should be installed so that the “240” marking is visible from the rear of the instrument.

If it is not set for the proper voltage, remove the fuse and then grasp the card with a pair of pliers and remove it. Rotate horizontally through 180 degrees. Reinstall the card and the correct fuse.

In the 120V setting, a 1.0A slow blow fuse is required. In the 240V setting, a 0.5A slow blow fuse is required.

2. **2.0A SB.** This fuse protects the output stage if the output duty cycle rating is exceeded.
3. **AMP.** To voltage control the output amplitude, set the switch in the EXT position and apply 0 to +10 Volts to the "A" BNC connector ($R_{IN} \geq 10 \text{ k}\Omega$).
4. **PW.** The pulse generator may be triggered externally in a $PW_{OUT} = PW_{IN}$ mode by setting this switch in the EXT position and the front panel INT/EXT/MAN switch in the EXT position and applying a TTL level pulse of the desired pulse width to the A BNC connector.

GENERAL INFORMATION

BASIC TEST ARRANGEMENT

The AV-1011-C-MSHA should normally be connected as shown below:

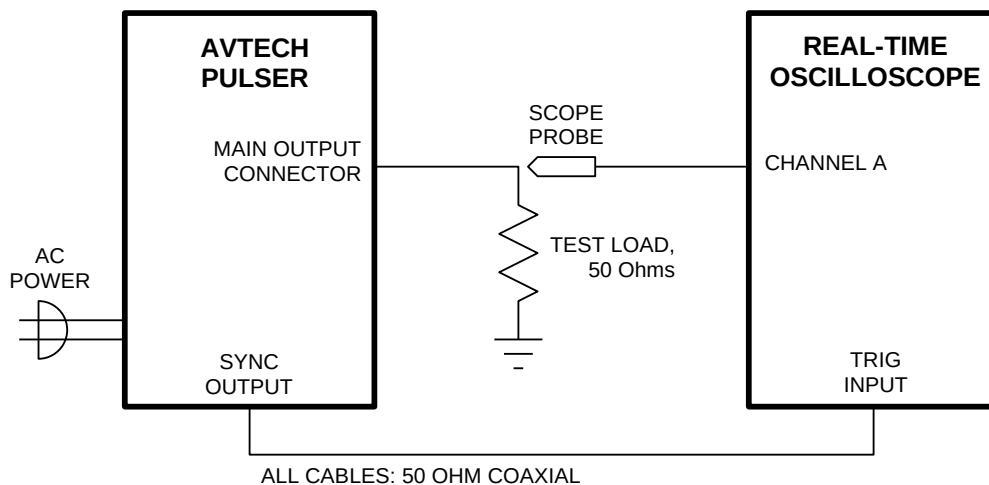

BASIC PULSE CONTROL

This instrument can be triggered by its own internal clock or by an external TTL trigger signal. When triggered internally, two mainframe output channels respond to the trigger: OUT and SYNC.

- OUT. This is the main output. The maximum output voltage is 50V.
- SYNC. The SYNC pulse is a fixed-width TTL-level reference pulse used to trigger oscilloscopes or other measurement systems.

When the ADVANCE/DELAY switch is set to "ADVANCE", the SYNC output precedes the main output. These pulses are illustrated below:

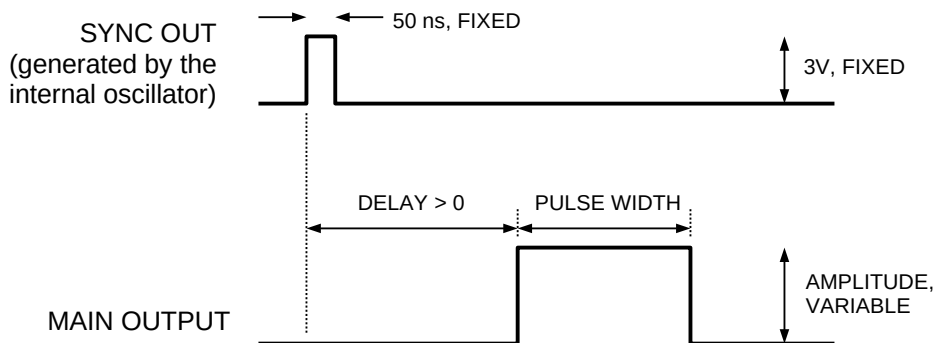

When the ADVANCE/DELAY switch is set to “DELAY”, the TRIG output occurs after the main output. This illustrated below:

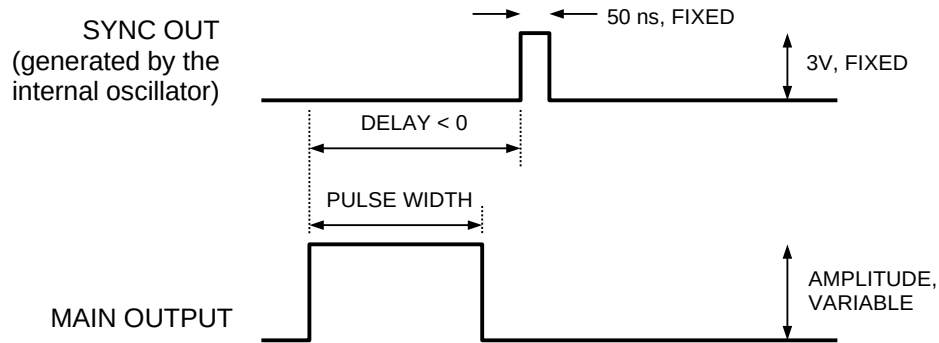

When triggered externally, the EXT TRIG connector acts as an input:

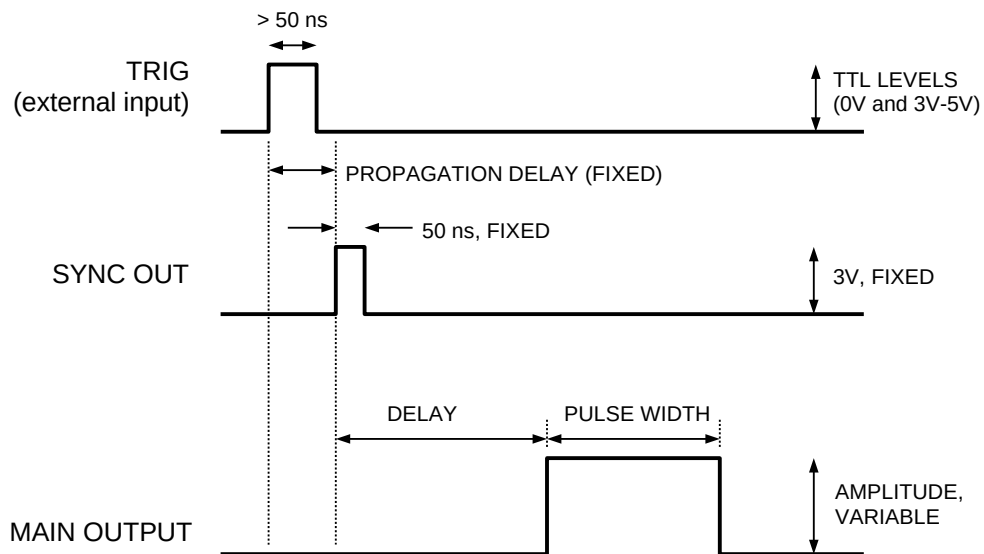

An external trigger may alternatively be applied to the rear-panel “PW” input. If the adjacent switch is set to “EXT”, the instrument will be triggered by this input, and the output pulse width will be approximately equal to the input pulse width. The front-panel timing controls are disabled in this mode.

MINIMIZING WAVEFORM DISTORTIONS

OUTPUT IMPEDANCE

The output impedance of the AV-1011-C-MSHA can be set at 2Ω or 50Ω using the amplitude range switch. The output impedance is 2Ω in the ±100V ranges, and 50Ω in the lower ranges.

When driving a high impedance load (i.e., $R_L \gg 50\Omega$), the amplitude range should be set so that the output impedance is 50Ω. This will minimize waveform ringing and transmission line reflections, without adversely affecting the pulse amplitude. In this configuration, the output voltage will be twice the voltage that would be observed into a 50Ω load (i.e., the +50V range will actually provide up to +100V).

When driving a 50Ω load, it is also highly desirable to set the output impedance to 50Ω. However, the output impedance and the load resistance will cause a resistive voltage-divider effect, reducing the output amplitude at the load by a factor of two. Thus, the 50Ω output impedance ranges can only be used to generate amplitudes of up to ±50V.

See Application Note 1A, at <http://www.avtechpulse.com/appnote/av1010/>, for more information.

GENERATING LOW-VOLTAGE WAVEFORMS

When generating low-voltage waveforms, the output waveforms will have much less distortion (i.e. ringing) if the output impedance is set to 50Ω.

USE 50Ω TRANSMISSION LINES

Connect the load to the pulse generator with 50Ω transmission lines (e.g. RG-58 or RG-174 cable). If possible, use a 50Ω load. If the actual device under test has a high impedance, consider adding a 50Ω termination in parallel with the load to properly terminate the transmission line.

Setting the pulse generator output impedance to 50Ω will “back-match” the transmission line, resulting in improved performance.

USE LOW-INDUCTANCE LOADS

Lenz's Law predicts that for an inductive voltage spike will be generated when the current through an inductance changes. Specifically, $V_{\text{SPIKE}} = L \times dI_{\text{LOAD}}/dt$, where L is the inductance, I_{LOAD} is the load current change, and t is time. For this reason, it is important to keep any parasitic in the load low. This means keeping wiring short, and

using low inductance components. In particular, wire-wound resistors should be avoided.

OPERATIONAL CHECK

This check is to confirm that the instrument is fully functional. Set the controls to the following values:

FRONT PANEL

- INT/EXT Switch: INT position
- REPETITION RATE RANGE Switch: 10 kHz
- REPETITION RATE Vernier: Maximum (fully clockwise)
- DELAY RANGE Switch: 1 us
- DELAY Vernier: MID range
- ADVANCE, DELAY, DOUBLE PULSE: DELAY
- PULSE WIDTH RANGE Switch: 1 us
- PULSE WIDTH Vernier: Maximum (fully clockwise)
- AMPLITUDE RANGE Switch: +100V
- AMPLITUDE Vernier: 5.0 (half-maximum)

REAR PANEL

- AMP: INT
- PW: INT

Connect a cable from the SYNC OUT connector to the TRIG input of an oscilloscope. Connect a 2W (or higher) 50 Ohm load to the OUT connector and place the scope probe across this load.

Set the oscilloscope to trigger externally with the vertical setting at 5 Volts/div and the horizontal setting at 1 us/div. Then follow the instructions below and compare what is seen on the oscilloscope to what is described. Only approximate values are needed to confirm operation.

STEP	CONTROL	OPERATION	RESULTS
1	POWER	Push in (ON)	+25V pulses at the main output, with period 100 us, pulse width 1.0 us, <10ns rise & fall times.
2	REPETITION RATE VERNIER	Rotate to Minimum (fully counter-clockwise), then to Maximum (fully clockwise)	Period rises to about 1 ms then falls to about 100 us.
3	DELAY VERNIER	Rotate to Maximum (fully clockwise), then to Minimum (fully counter-clockwise)	Pulses shift to the right on the oscilloscope by 1 us, then back.
4	PULSE WIDTH VERNIER	Rotate to Minimum (fully counter-clockwise), then to Maximum (fully clockwise)	Pulse width varies from 100 ns to 1.0 us.
5	AMPLITUDE RANGE SWITCH	Switch to -50V, then to +50V	Pulse polarity becomes negative & then positive.
6	AMPLITUDE RANGE SWITCH	Switch to +100V	The output pulse amplitude will jump to +50V.

MECHANICAL INFORMATION

TOP COVER REMOVAL

If necessary, the interior of the instrument may be accessed by removing the four Phillips screws on the top panel. With the four screws removed, the top cover may be slid back (and off).

Always disconnect the power cord before opening the instrument.

There are no user-adjustable internal circuits. For repairs other than fuse replacement, please contact Avtech (info@avtechpulse.com) to arrange for the instrument to be returned to the factory for repair.

⚠ Caution: High voltages are present inside the instrument during normal operation. Do not operate the instrument with the cover removed.

RACK MOUNTING

A rack mounting kit is available. The -R5 rack mount kit may be installed after first removing the one Phillips screw on the side panel adjacent to the front handle.

ELECTROMAGNETIC INTERFERENCE

To prevent electromagnetic interference with other equipment, all used outputs should be connected to shielded 50Ω loads using shielded 50Ω coaxial cables. Unused outputs should be terminated with shielded 50Ω coaxial terminators or with shielded coaxial dust caps, to prevent unintentional electromagnetic radiation. All cords and cables should be less than 3m in length.

MAINTENANCE

REGULAR MAINTENANCE

This instrument does not require any regular maintenance.

On occasion, one or more of the four rear-panel fuses may require replacement. All fuses can be accessed from the rear panel.

CLEANING

If desired, the interior of the instrument may be cleaned using compressed air to dislodge any accumulated dust. (See the "TOP COVER REMOVAL" section for instructions on accessing the interior.) No other cleaning is recommended.

PERFORMANCE CHECK SHEET