



AVTECH ELECTROSYSTEMS LTD.

NANOSECOND WAVEFORM ELECTRONICS
SINCE 1975

□ P.O. BOX 265
OGDENSBURG, NY
U.S.A. 13669-0265
TEL: (315) 472-5270
FAX: (613) 226-2802

TEL: 1-800-265-6681
FAX: 1-800-561-1970

e-mail: info@avtechpulse.com
<http://www.avtechpulse.com>

□ P.O. BOX 5120 STN. F
OTTAWA, ONTARIO
CANADA K2C 3H4
TEL: (613) 226-5772
FAX: (613) 226-2802

INSTRUCTIONS

MODEL AV-1015-C

±50 V, 10 MHz
PULSE-DELAY GENERATOR

SERIAL NUMBER: _____

WARRANTY

Avtech Electrosystems Ltd. warrants products of its manufacture to be free from defects in material and workmanship under conditions of normal use. If, within one year after delivery to the original owner, and after prepaid return by the original owner, this Avtech product is found to be defective, Avtech shall at its option repair or replace said defective item. This warranty does not apply to units which have been disassembled, modified or subjected to conditions exceeding the applicable specifications or ratings. This warranty is the extent of the obligation assumed by Avtech with respect to this product and no other warranty or guarantee is either expressed or implied.

TECHNICAL SUPPORT

Phone: 613-226-5772 or 1-800-265-6681

Fax: 613-226-2802 or 1-800-561-1970

E-mail: info@avtechpulse.com

World Wide Web: <http://www.avtechpulse.com>

EC DECLARATION OF CONFORMITY

We

Avtech Electrosystems Ltd.
P.O. Box 5120, Stn. F
Ottawa, Ontario
Canada K2C 3H4

declare that the AV-1015-C pulse generator meets the intent of Directive 89/336/EEC for Electromagnetic Compatibility. Compliance pertains to the following specifications as listed in the official Journal of the European Communities:

EN 50081-1 Emission

EN 50082-1 Immunity



TABLE OF CONTENTS

WARRANTY	_____
TECHNICAL SUPPORT	_____
EC DECLARATION OF CONFORMITY	_____
TABLE OF CONTENTS	_____
INTRODUCTION	_____
SPECIFICATIONS	_____
INSTALLATION	_____
VISUAL CHECK	_____
PLUGGING IN THE INSTRUMENT	_____
OPERATIONAL CHECK	_____
FRONT PANEL CONTROLS	_____
REAR PANEL CONTROLS	_____
GENERAL INFORMATION	_____
TOP COVER REMOVAL AND RACK MOUNTING	_____
ELECTROMAGNETIC INTERFERENCE	_____
THEORY OF OPERATION AND BASIC CIRCUITS	_____
PS-PN MODULE	_____
POSITIVE PULSE GENERATOR MODULE	_____
NEGATIVE PULSE GENERATOR MODULE	_____
POLR MODULE	_____



INTRODUCTION

The Model AV-1015-C is a high performance instrument capable of 50 W peak pulse power at repetition rates up to 10 MHz. The output polarity is selectable and the amplitude is variable up to 50 V into 50 Ohms. Pulse delay, advance and width are variable up to 10 ms. Rise and fall times are fixed at less than 10 ns. Model AV-1015-C provides single or double pulse output and can be triggered or gated by an external source. The output pulse width can be set to follow an input trigger pulse width and the output amplitude can be controlled by an externally applied 0 to +10 Volts DC control voltage.

SPECIFICATIONS

Model:	AV-1015-C
Output amplitude ¹ :	0.3V to 50V, into 50Ω
Output polarity:	+ or -, switch-selectable
Rise time, fall time:	≤ 10 ns
Pulse aberrations:	≤ ± 5 % of amplitude
Pulse width ² :	20 ns to 10 ms ²
Jitter:	Pulse width: ≤ .1%, typically < .01% Delay/Advance: ≤ .1%, + 0.5 ns Period: ≤ .1%, + 0.5 ns
Pulse repetition rate:	10 Hz to 10 MHz
Maximum duty cycle:	50% for 1V, 5V, 15V amplitude ranges 25% for 50V amplitude range
Output impedance:	50Ω in the 1V, 5V and 15V ranges 2Ω in the 50V range
Double pulse spacing:	100ns to 10 ms
Delayed/advanced pulse range:	0 to 10 ms, (relative to SYNC OUT)
Sync output:	+3 Volts, 50 ns (R _L > 1 kΩ)
Gated operation:	Triggering suppressed when the gate input is grounded (0 Volts)
External trigger:	Mode A: TTL (0 - 5V), > 50 ns width Mode B: TTL (0 - 5V), PW _{IN} = PW _{OUT} Includes single-pulse pushbutton
Minimum propagation delay, external trigger modes:	Advance: 75 ns Delay: 125 ns Double pulse: 75 ns PW _{IN} = PW _{OUT} : 50 ns
Protected against:	open and short circuits, high duty cycle
Connectors:	BNC female
Mechanical, power, temperature:	See AV-1010-C data sheet
Accessories included:	6' power cord, instruction manual
Option available:	19" rack mount kit

- 1) The output amplitude may also be controlled by applying 0 to +10 Volts DC to a rear panel banana connector.
- 2) The output pulse width may also be controlled externally by applying a TTL level trigger of the desired width to a rearpanel banana connector (PW_{IN} = PW_{OUT} mode).

INSTALLATION

VISUAL CHECK

After unpacking the instrument, examine to ensure that it has not been damaged in shipment. Visually inspect all connectors, knobs and the handles. Confirm that a power cord and instrumentation manual are with the instrument. (If the instrument has been damaged, file a claim immediately with the company that transported the instrument).

PLUGGING IN THE INSTRUMENT

Examine the rear of the instrument. There will be a male power receptacle, a fuse holder and the edge of the power selector card visible. Confirm that the power selector is in the correct orientation - it should be marked either 120 or 240, indicating whether it expects 120V AC or 240V AC. If it is not set for the proper voltage, remove the fuse and then grasp the card with a pair of pliers and remove it. Rotate horizontally through 180 degrees. Reinstall the card and the correct fuse. In the 120V setting, a 1.0A slow blow fuse is required. In the 240V setting, a 1/2A slow blow fuse is required.

OPERATIONAL CHECK

This check is to confirm that the instrument is fully operational. Set the controls to the following values:

FRONT PANEL

- INT/EXT Switch: INT position
- REPETITION RATE RANGE Switch: 10 kHz
- REPETITION RATE Vernier: MAX
- DELAY RANGE Switch: 1 us
- DELAY Vernier: MID range
- ADVANCE, DELAY, DOUBLE PULSE: DELAY
- PULSE WIDTH RANGE Switch: 1 us
- PULSE WIDTH Vernier: MAX
- POLARITY Switch: +
- AMPLITUDE RANGE Switch: 15V

- AMPLITUDE Vernier: MAX

REAR PANEL

- AMP: INT
- PW: INT
 - HV: ON

Connect a cable from the SYNC OUT connector to the TRIG input of an oscilloscope. Connect a 2W (or higher) 50 Ohm load to the OUT connector and place the scope probe across this load.

Set the oscilloscope to trigger externally with the vertical setting at 5 Volts/div and the horizontal setting at 1 us/div. Then follow the instructions below and compare what is seen on the oscilloscope to what is described. Only approximate values are needed to confirm operation.

STEP	CONTROL	OPERATION	RESULTS
1	POWER	Push in (ON)	+15V pulses at the main output, with period 100 us, pulse width 1.0 us, < 10ns rise & fall times.
2	REPETITION RATE VERNIER	Rotate to MIN, then to MAX	Period rises to about 1 ms then falls to about 100 us.
3	DELAY VERNIER	Rotate to MAX, then to MIN	Pulses shift to the right on the oscilloscope by 1 us, then back.
4	PULSE WIDTH VERNIER	Rotate to MIN, then to MAX	Pulse width varies from 100 ns to 1.0 us.
5	AMPLITUDE RANGE	Switch to 50 Volts and then back to 15	The output pulse amplitude will jump to 50 Volts and then will decay slowly to 15 Volts.

This completes the operational check.

FRONT PANEL CONTROLS

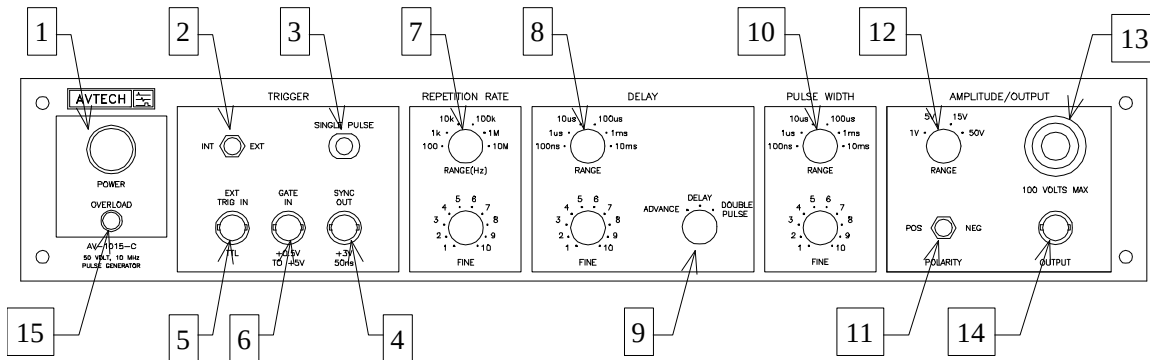

(1) POWER Switch. The POWER push button switch applies AC prime power to the primaries of the transformer, turning the instrument on. The push button lamp (#382 type) is connected to the +15V DC supply.

(2) INT/EXT Switch. In the "INT" position the instrument is internally triggered and the "SYNC OUT" connector provides a SYNC output which allows one to trigger other instruments, such as oscilloscopes. In the "EXT" position the instrument is triggered by a +5V 50 ns (or wider) input pulse on the "TRIG IN" connector, or by pressing the "SINGLE PULSE" push button.

(3) SINGLE PULSE Push Button. The "SINGLE PULSE" push button will trigger the instrument manually for one cycle of output, when the "INT/EXT" switch is in the "EXT" position. Otherwise, the push button has no effect.

(4) SYNC OUT. When the "INT/EXT" switch is in the "INT" position, this connector supplies a SYNC output that can be used to trigger other equipment, particularly oscilloscopes. This signal leads, or lags, the main output by a duration set by the "DELAY" controls and has an approximate amplitude of +3 Volts to $R_L > 1K$ with a pulse width of about 50 ns.

(5) TRIG IN. When the "INT/EXT" switch is in the "EXT" position, the external trigger (+5 Volts, PW 50 ns) is applied to this connector. This input presents a high impedance (1 M Ohm).

(6) GATE Input. The GATE input will suppress the triggering of the instrument if taken to a TTL HIGH level (i.e. 0.5 to 5.0V). If it is left open or taken to a TTL LOW, normal triggering will occur ($R_{IN} = 1K$).

(7) REPETITION RATE Controls. The rotary switch marked "RANGE" selects the pulse repetition rate for the internally triggered mode. The vernier (labeled "MIN-MAX") provides continuously variable control of each range. There are six ranges and the instrument is set to the rate indicated on the front panel when the vernier is in the "MAX" position.

10 Hz - 100 Hz
 100 Hz - 1 kHz
 1 kHz - 10 kHz
 10 kHz - 100 kHz
 100 kHz - 1.0 MHz
 1.0 MHz - 10 MHz

(8) DELAY Controls. The rotary switch selects one of six ranges and the vernier provides continuously variable control of each range. The instrument is set to the delay indicated on the front panel when the vernier is in the "MAX" position.

20 ns - 100 ns
 100 ns - 1 us
 1 us - 10 us
 10 us - 100 us
 100 us - 1 ms
 1 ms - 10 ms

(9) ADVANCE, DELAY, DOUBLE PULSE. With this three position switch in the ADVANCE position, the leading edge of the output pulse precedes the leading edge of the SYNC output. When in the DELAY position, the leading edge of the SYNC output precedes the leading edge of the main output. When in the DOUBLE PULSE position, the main output provides two successive output pulses having a separation determined by the DELAY (8) controls.

(10) PULSE WIDTH Controls. The rotary switch selects one of six ranges and the vernier provides continuously variable control of each range. The instrument is set to the pulse width indicated on the front panel when the vernier is in the "MAX" position.

20 ns - 100 ns
 100 ns - 1 us
 1 us - 10 us
 10 us - 100 us
 100 us - 1 ms
 1 ms - 10 ms

(11) POLARITY Switch. If the polarity switch is in the "+" position, the main output pulse will pulse upwards (i.e. to a more positive level). If it is in the "-" position, the output will pulse downwards to a more negative level. If the setting of the polarity switch is changed when the output amplitude is relatively high (eg. > 10 Volts in the 50 Volt range), the output pulse will vanish for several tens of seconds until the high voltage levels on the output stage decay to a safe level. At that time the output will again become active. Note that the decay-delay time may be reduced significantly by briefly setting the rear panel HV switch in the "OFF" position (and then returning it to the "ON" position).

(12) AMPLITUDE RANGE Switch. The rotary switch selects one of four ranges and the vernier (13) provides continuously variable control of each range. The instrument is set to the amplitude indicated on the front panel when the vernier is in the "MAX" position.

0 to 1 Volt	($Z_{OUT} = 50 \text{ Ohm}$)
0 to 5 Volts	($Z_{OUT} = 50 \text{ Ohm}$)
0 to 15 Volts	($Z_{OUT} = 50 \text{ Ohm}$)
0 to 50 Volts	($Z_{OUT} = 2 \text{ Ohm}$)

(13) AMPLITUDE FINE. The ten turn amplitude vernier provides continuously variable control of the peak amplitude of the main output from 0 Volts to the maximum set by the range switch (see (12)). When the unit is operating at a low duty cycle and an attempt is made to reduce the output amplitude, the amplitude will decay slowly with a time constant of several tens of seconds. If a rapid decay is required, briefly switch the rear panel HV switch to the "OFF" position (and then back to the "ON" position).

(14) OUT. BNC connector provides output to load impedance of 50 Ohms or higher.

(15) OVERLOAD. An automatic overload protective circuit controls the front panel overload light. If the unit is overloaded (by operating at an exceedingly high duty cycle or by operating into a very low impedance), the protective circuit will turn the output of the instrument OFF and turn the indicator light ON. The light will stay ON (i.e. output OFF) for about 5 seconds after which the instrument will attempt to turn ON (i.e. light OFF) for about 1 second. If the overload condition persists, the instrument will turn OFF again (i.e. light ON) for another 5 seconds. If the overload condition has been removed, the instrument will turn on and resume normal operation. Overload conditions may be removed by:

- 1) Reducing PRF (i.e. switch to a lower range)
- 2) Reducing pulse width (i.e. switch to a lower range)
- 3) Removing output low load impedance (if any)
- 4) Reducing the output amplitude (i.e. switch to a lower range)

The overload light may illuminate when the prime power is first applied. The light will extinguish after a few seconds and the unit will then operate normally.

Note that the output stage will safely withstand a short circuited load condition.

REAR PANEL CONTROLS

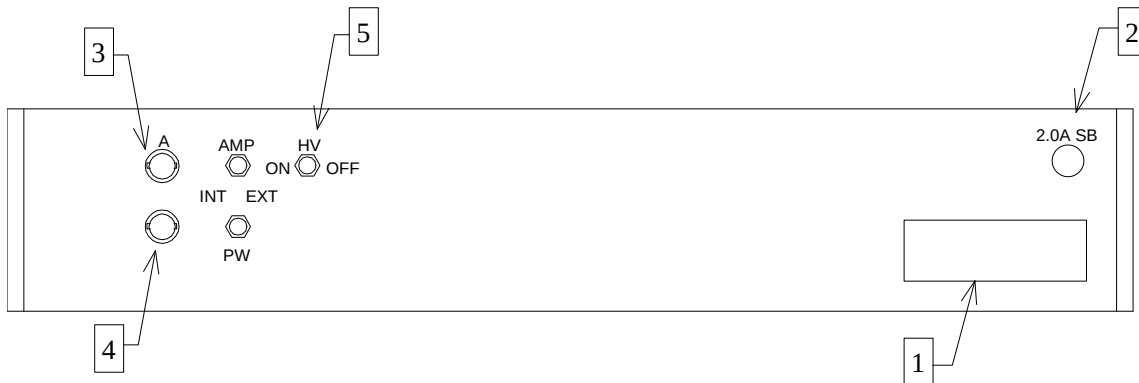

(1) AC POWER INPUT. A three-pronged recessed male connector is provided on the back panel for AC power connection to the instrument. Also contained in this assembly is a 1.0A slow blow fuse and a removable card that can be removed and repositioned to switch between 120V AC in and 240V AC in.

(2) 2.0A SB. This fuse protects the output stage if the output duty cycle rating is exceeded.

(3) AMP. To voltage control the output amplitude, set the switch in the EXT position and apply 0 to +10 Volts between terminal A and ground ($R_{IN} > 10K$). The front panel controls are still active in this mode.

(4) PW. The pulse generator may be triggered externally in a $PW_{OUT} = PW_{IN}$ mode by setting the switch in the EXT position and applying a TTL level pulse of the desired pulse width to the A connector.

(5) HV SWITCH. This switch must be in the "ON" position to obtain an output pulse. Note when the unit is operating at a low duty cycle and an attempt is made to reduce the output amplitude, the amplitude will decay slowly with a time constant of several tens of seconds. If a rapid decay is required, briefly switch the rear panel HV switch to the "OFF" position (and then back to the "ON" position). Also note that if the output pulse vanishes due to a changing of the position of the polarity (see paragraph 12, Front Panel Controls), the pulse recovery time may be reduced significantly by briefly setting the HV switch in the "OFF" position (and then returning it to the "ON" position).

GENERAL INFORMATION

TOP COVER REMOVAL AND RACK MOUNTING

- 1) The interior of the instrument may be accessed by removing the four Phillips screws on the top panel. With the four screws removed, the top cover may be slid back (and off).
- 2) The -R5 rack mount kit may be installed after first removing the one Phillips screw on the side panel adjacent to the front handle.

ELECTROMAGNETIC INTERFERENCE

To prevent electromagnetic interference with other equipment, all used outputs should be connected to shielded 50 Ohm loads using shielded 50 Ohm coaxial cables. Unused outputs should be terminated with shielded 50 Ohm BNC terminators or with shielded BNC dust caps, to prevent unintentional electromagnetic radiation. All cords and cables should be less than 3m in length.

THEORY OF OPERATION AND BASIC CIRCUITS

Refer to the attached Block Diagram for the following explanation.

The instrument is triggered by either an internal oscillator or an external source.

The INT/EXT switch controls a gate that selects either the internal oscillator or the output of the threshold comparator. The output of this gate leads to an AND gate. The second input of the AND gate is the TTL complement of the GATE input, so that when the GATE input is TTL low (0V), the AND gate passes the trigger pulses and inhibits them when the GATE input is high.

At this point, the trigger signal is split into two parts. The lower channel drives a one-shot circuit, which delays the pulse, which is then buffered. The upper channel is buffered only. When in the DELAY or DOUBLE PULSE modes, the upper channel is connected, by a switch, to the front panel SYNC output. In the ADVANCE mode, the lower channel is connected instead.

The two channels then pass through the double-pulse circuitry. When in the ADVANCE or DELAY modes, both signal pass unaltered. In the DOUBLE PULSE mode, the upper channel is unaltered, but the two input channels are combined to create a new signal on the lower channel, yielding a series of double pulses.

When in the ADVANCE mode, the upper channel is switched in to drive the next circuit stage, the pulse width controller. In the DELAY or DOUBLE PULSE mode, the delayed

lower channel drives the pulse width circuit. The output of the pulse width stage is a TTL pulse whose pulse width is equal to the pulse width of the instrument's front panel output.

At this stage, the user has the option of completely bypassing the instrument's timing circuitry by using the back panel PW switch and input connector. When the switch is in the INT position, the output of the pulse width stage is connected to the output stages of the instrument. In the EXT position, the output stages can be driven by TTL pulses on the back panel connector.

The output stages are all-solid-state, MOSFET totem pole circuits. There is a positive output and a negative output stage and the polarity switch selects one of the two outputs. The pulse width of the output pulse is equal to the pulse width of the input pulse and the amplitude of the output pulse is controlled by a combination of the DC voltage applied to the circuit and T-attenuators selected by the Amplitude Range switch.

PS-PN MODULE

The PS-PN module supplies DC power to various other modules in the AV-1015. The PS-PN is supplied with +24VDC on pin 9. It, in turn, supplies -15V from pin 10. This module also provides the high voltage power to the two pulse generator modules. Pin 7 supplies +10V to the AMP FINE potentiometer. This control divides this voltage down to somewhere between 0 and 10V, which is then supplied to either pin 1 or 2, depending on the position of the polarity switch. If the polarity switch is in the POS position, the voltage is applied to pin 1 and +24V is supplied to pin 3. The PS-PN module amplifies the voltage on pin 3 by a factor of +5.5 using high voltage operational amplifiers and supplies this high voltage to pin 5 which then connects to pin 4 of the positive pulse generator module. Similarly, if the polarity switch is in the NEG position, the AMP FINE pot varies the voltage on pin 2 between 0 and +10V and +24VDC is supplied to pin 4, which activates the amplifier that supplies 0 to -55V to pin 6. Pin 6 connects to pin 4 of the negative pulse generator.

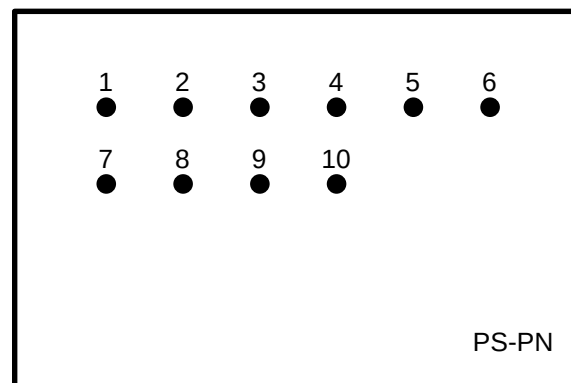

Pin connections

1. Positive Amplitude Control. The voltage on this pin is amplified by a factor of +5.5 and the amplified voltage is supplied to pin 5.
2. Negative Amplitude Control. The voltage on this pin is amplified by a factor of -5.5 and the amplified voltage is supplied to pin 6.
3. +24V In. When +24V is applied to this pin, the positive amplifier (that amplifies the voltage on pin 1) is enabled.
4. +24V In. When +24V is applied to this pin, the negative amplifier (that amplifies the voltage on pin 2) is enabled.
5. 0 to + 55V Out. This voltage is equal to the voltage on pin 1 multiplied by +5.5. This supplies power to pin 4 of the positive pulse generator module.
6. 0 to -55V Out. This voltage is equal to the voltage on pin 1 multiplied by -5.5. This supplies power to pin 4 of the negative pulse generator module.

7. +10V Out
8. No connection
9. +24V In.
10. -15V Out

POSITIVE PULSE GENERATOR MODULE

The positive pulse generator module has an all-solid-state totem pole MOSFET output stage. A TTL level input, applied to pin 1, triggers the module. The input source is either the pulse width circuit on the front-panel board or a connector on the back panel of the instrument, selected by rear panel control (4). The output pulse width is equal to the input pulse width and the output amplitude is equal to the voltage on pin 4 (which can vary between 0 and +55 V) minus a voltage drop due to the module's 2 Ohm output resistance. The voltage on pin 4 is controlled by the PS-PN module which, in turn, is controlled by the AMP RANGE SWITCH and the AMP FINE potentiometer. Pin 4 is bypassed with large energy-storage capacitors to minimize droop.

The module's output is taken from the SMA connector and fed into the range selector board. When not in the 50V range, the output is connected to one of several T attenuators, depending on the voltage range.

When the polarity switch is in the POS position, the module is supplied with power by the +24VDC solder terminal on the rear of the module.

The MOSFET transistors (AVTECH Part No SL28T) are field replaceable and are accessed by removing the 5 cm x 10 cm cover plate on the bottom of the instrument. The two SL28T transistors in each module are bonded to a copper heat sink using-WAKEFIELD TYPE 155 thermally conductive epoxy. The copper heat sink is attached to the bottom surface of the -PG module by four 2-56 screws.

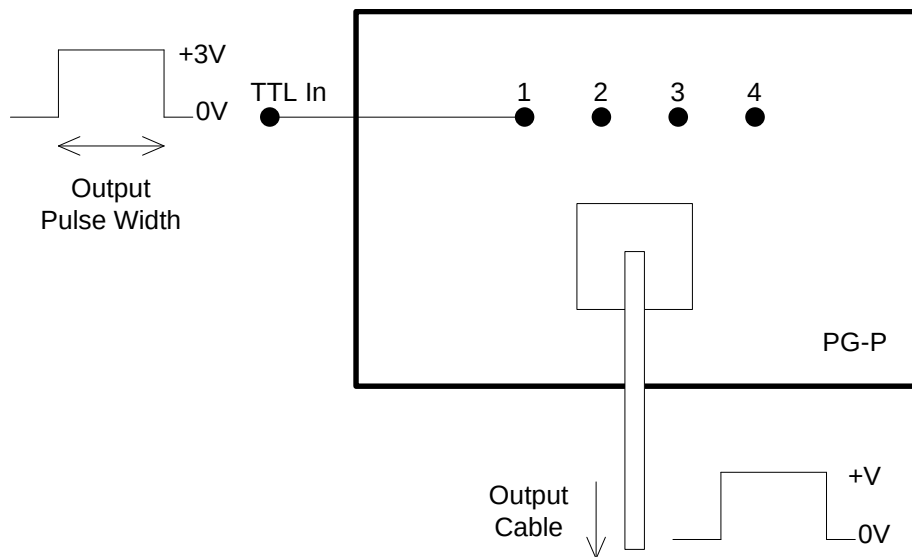

Pin connections

1. TTL In. Connected to either pin 2 of the pulse width module or to a back-panel connector.
2. No connection
3. No connection
4. Amplitude Control Voltage. This sets the output amplitude of the module. Connected to pin 5 of PS-PN module.

SMA. Output.

Rear. +24VDC in

NEGATIVE PULSE GENERATOR MODULE

The negative pulse generator module has an all-solid-state totem pole MOSFET output stage. A TTL level input, applied to pin 1, triggers the module. The input source is either the pulse width circuit on the front-panel board or a connector on the back panel of the instrument, selected by rear panel control (4). The output pulse width is equal to the input pulse width and the output amplitude is equal to the voltage on pin 4 (which can vary between 0 and -55 V) minus a voltage drop due to the module's 2 Ohm output resistance. The voltage on pin 4 is controlled by the PS-PN module which, in turn, is controlled by the AMP RANGE SWITCH and the AMP FINE potentiometer. Pin 4 is bypassed with large energy-storage capacitors to minimize droop.

The module's output is taken from the SMA connector and fed into the range selector board. When not in the 50V range, the output is connected to one of several T attenuators, depending on the voltage range.

When the polarity switch is in the NEG position, the module is supplied with power by the +24VDC solder terminal on the rear of the module.

The MOSFET transistors (AVTECH Part No SL28T) are field replaceable and are accessed by removing the 5 cm x 10 cm cover plate on the bottom of the instrument. The two SL28T transistors in each module are bonded to a copper heat sink using WAKEFIELD TYPE 155 thermally conductive epoxy. The copper heat sink is attached to the bottom surface of the -PG module by four 2-56 screws.

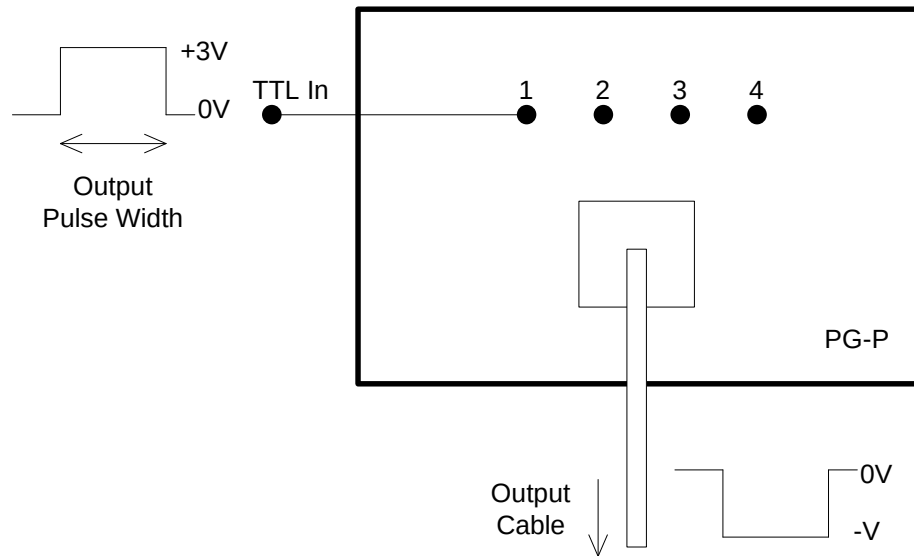

Pin connections

1. TTL In. Connected to either pin 2 of the pulse width module or to a back-panel connector.
2. No connection
3. No connection
4. Amplitude Control Voltage. This sets the output amplitude of the module. Connected to pin 6 of PS-PN module.

SMA. Output.

Rear. +24VDC in

POLR MODULE

The POLR module is designed to prevent the output polarity from being reversed while the output amplitude is high. This prevents damage to the output stages.