

INSTRUCTIONS

MODEL AV-1022-C-AS4

5 V, 1 MHz LAB
PULSE-DELAY GENERATOR

SERIAL NUMBER: _____

WARRANTY

Avtech Electrosystems Ltd. warrants products of its manufacture to be free from defects in material and workmanship under conditions of normal use. If, within one year after delivery to the original owner, and after prepaid return by the original owner, this Avtech product is found to be defective, Avtech shall at its option repair or replace said defective item. This warranty does not apply to units which have been disassembled, modified or subjected to conditions exceeding the applicable specifications or ratings. This warranty is the extent of the obligation assumed by Avtech with respect to this product and no other warranty or guarantee is either expressed or implied.

TECHNICAL SUPPORT

Phone: 613-226-5772 or 1-800-265-6681

Fax: 613-226-2802 or 1-800-561-1970

E-mail: info@avtechpulse.com

World Wide Web: <http://www.avtechpulse.com>

TABLE OF CONTENTS

WARRANTY	_____
TECHNICAL SUPPORT	_____
TABLE OF CONTENTS	_____
INTRODUCTION	_____
SPECIFICATIONS	_____
INSTALLATION	_____
VISUAL CHECK	_____
PLUGGING IN THE INSTRUMENT	_____
OPERATIONAL CHECK	_____
FRONT PANEL CONTROLS	_____
GENERAL INFORMATION	_____
BASIC PULSE CONTROL	_____
ELECTROMAGNETIC INTERFERENCE	_____
TOP AND BOTTOM COVER REMOVAL	_____
USER-ACCESSIBLE INTERNAL ADJUSTMENTS	_____
USING THE GPIB INTERFACE	_____
INTERFACE TO THE GPIB	_____
AVAILABLE COMMANDS	_____
COMMAND INTERPRETATION	_____
TYPICAL COMMAND SEQUENCE INTERPRETATION	_____
SAMPLE PROGRAM	_____
CHANGING THE UNIT GPIB ADDRESS	_____
TROUBLE-SHOOTING AID	_____
MAINTENANCE	_____
MECHANICAL LAYOUT	_____
KEY FUNCTIONAL AREAS	_____
PARTS LIST	_____
CIRCUIT AND WIRING DIAGRAMS	_____

INTRODUCTION

The AV-1022-C-AS4 is a general-purpose lab pulse-delay generator, which can generate waveforms of 0 to +5V in amplitude, at frequencies up to 1 MHz. Internal protection circuits limit the output duty cycle to less than 45% ($\pm 2\%$). The AV-1022-C-AS4 will drive 50 Ω loads, and has a 50 Ω output impedance. The output rise and fall times are 10 ns or less.

A monitor output is provided, which has the same pulse width, delay and frequency as the main output. The monitor amplitude is fixed at +1V (into a 50 Ω load).

The instrument can be controlled either by the front-panel controls, or via the GPIB IEEE-488 computer interface. The control method is selected by a switch on the back panel of the AV-1022-C-AS4.

SPECIFICATIONS

Model:	AV-1022-C-AS4
Pulse Repetition Rate:	100 Hz to 1 MHz
Amplitude (to 50 Ω):	0V (≤ 20 mV) to +5V (± 0.2 V)
Source Impedance:	50 Ω
Delay (relative to SYNC output):	50 ns to 50 μ s
Pulse width (PW):	50 ns to 50 μ s
Rise time, fall time:	10 ns
Maximum duty cycle:	45% ($\pm 2\%$)
Duty cycle protection:	Triggering is inhibited if the settings would result in a duty cycle greater than 45% ($\pm 2\%$). An overload indicator on the front panel lights when this occurs.
Trigger required (Ext trig mode):	+5 Volts, ≥ 40 ns TTL
Monitor output:	+1V into 50 Ω (+4V into 1k Ω) with same delay, pulse width, and frequency as the main output
Period, delay and pulse width jitter:	$< \pm 0.1\%$ of setting ± 50 ps
Period, delay and pulse width long-term average instability:	$< \pm 0.5\%$ of setting
Sync output:	+2 Volts, 50 ns, will drive 50 Ω loads
Signal connectors:	BNC
Power requirement:	120/240 Volts (switchable), 50 - 60 Hz
Dimensions (H x W x D):	100 mm x 215 mm x 315 mm 3.9" x 8.5" x 14.8"
Temperature range:	+10 $^{\circ}$ C to +40 $^{\circ}$ C

INSTALLATION

VISUAL CHECK

After unpacking the instrument, examine to ensure that it has not been damaged in shipment. Visually inspect all connectors, knobs and the handles. Confirm that a power cord and instrumentation manual are with the instrument. (If the instrument has been damaged, file a claim immediately with the company that transported the instrument).

PLUGGING IN THE INSTRUMENT

Examine the rear of the instrument. There will be a male power receptacle, a fuse holder and the edge of the power selector card visible. Confirm that the power selector is in the correct orientation - it should be marked either 120 or 240, indicating whether it expects 120V AC or 240V AC. If it is not set for the proper voltage, remove the fuse and then grasp the card with a pair of pliers and remove it. Rotate horizontally through 180 degrees. Reinstall the card and the correct fuse. In the 120V setting, a 1/2A slow blow fuse is required. In the 240V setting, a 1/4A slow blow fuse is required.

OPERATIONAL CHECK

This check is to confirm that the instrument is fully operational. Set the controls to the following values:

- REPETITION RATE range switch: 100 kHz position
- REPETITION RATE fine control: fully counter-clockwise (minimum frequency)

- PULSE DELAY range switch: 50us position
 - PULSE DELAY fine control: fully counter-clockwise (minimum delay)

- PULSE WIDTH range switch: 5us position
 - PULSE WIDTH fine control: fully clockwise (maximum pulse width)

- AMPLITUDE fine control: fully clockwise (maximum amplitude)
 - REMOTE/LOCAL switch (on the back panel): LOCAL

Connect a 50 Ω coaxial cable from the SYNC connector to the TRIG input of an oscilloscope. Connect 50 Ω , 2 Watt load between the OUT connector signal line and ground. Connect an oscilloscope probe to the main output.

Set the oscilloscope to trigger externally with the vertical setting at 2 Volts/div and the horizontal setting at 20 μ s/div. Then follow the instructions below and compare what is seen on the oscilloscope to what is described. Only approximate values are needed to confirm operation.

STEP	CONTROL	OPERATION	RESULTS
1	POWER	Push in (on) and wait for a 5 minute warm-up period.	+5V pulses with period 100 μ s, pulse width 5 μ s, and rise & fall times of 10 ns.
2	PULSE DELAY fine control	Rotate fully clockwise, then fully counter-clockwise	The pulses shift to the right on the oscilloscope by 50 μ s, then back
3	PULSE WIDTH fine control	Rotate fully counter-clockwise, then fully clockwise	The pulses narrow to 0.5 μ s, then widen back to 5 μ s.
4	REPETITION RATE fine control	Rotate fully clockwise, then fully counter-clockwise	Period falls to 11.1 μ s, at which point the duty cycle exceeds 45% and the pulse triggering will stop. The overload indicator will come on. When the knob is rotated counter-clockwise, the period will increase and triggering will resume.
5	AMPLITUDE fine control	Rotate fully counter-clockwise, then fully clockwise	The pulse amplitude falls to 0 V, then rises back to +5 V.

Steps 1 to 5 confirm that the pulse delay, pulse width, amplitude controls, and the duty cycle limit and internal clock circuit (controlled by the REPETITION RATE controls) are functioning properly.

Step 6 is optional, and is to confirm that the instrument can be triggered externally. First connect a pulse generator or other signal source with a 10 kHz frequency, a pulse with of at least 40ns, and TTL logic levels (0 and 5V) to the EXT TRIG input connector. (The voltage applied to this input must not go below zero volts, or exceed +5V.) Then proceed with step 6:

6	REPETITION RATE range switch	Set at "EXT"	+5V pulses with period 100 μ s, pulse width 5 μ s, and rise & fall times of 10 ns.
---	------------------------------	--------------	--

Step 7 and 8 are optional, and are to confirm that the GPIB interface is operating.

7	REMOTE/LOCAL switch (on the back panel)	Set at "REMOTE"	No output pulses. Zero volts out.
---	---	-----------------	-----------------------------------

In the absence of computer commands, the AV-1022-C-AS4 defaults to a quiescent zero-amplitude state when in the REMOTE mode. This is demonstrated by step 7.

To fully test the instrument's REMOTE mode, a computer with a properly-configured GPIB controller card and the appropriate software is required. Connect the controller to the AV-1022-C-AS4's rear-panel GPIB connector using the supplied GPIB cable. The AV-1022-C-AS4 is shipped with its GPIB address set at "8". Send the following sequence of four commands to the AV-1022-C-AS4 via the GPIB bus:

```
R10000
W5
D5
V5
```

Then observe the output on the oscilloscope.

8	GPIB interface.	Send GPIB commands.	+5V pulses with period 100 μ s, delay 5 μ s, pulse width 5 μ s, and rise & fall times of 10 ns.
---	-----------------	---------------------	---

This completes the operational check.

FRONT PANEL CONTROLS

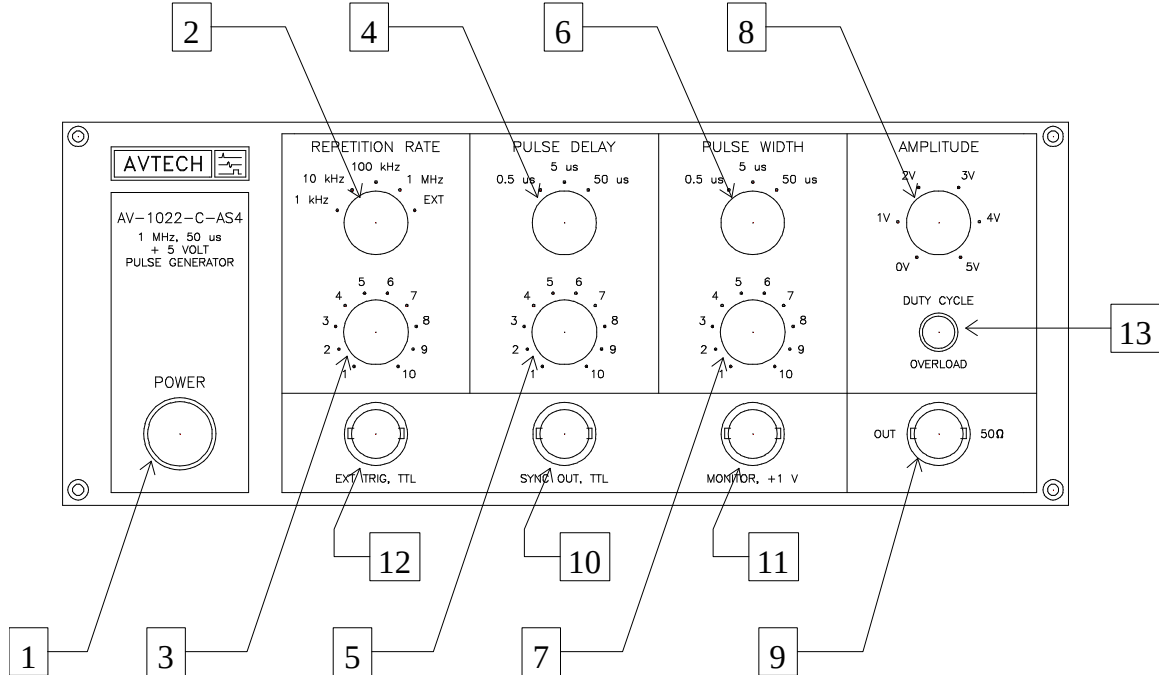

(1) POWER switch. The POWER pushbutton switch applies AC prime power to the primaries of the transformer, turning the instrument on.

(2) REPETITION RATE range switch. This selects one of the five pulse repetition rate ranges:

100 Hz - 1 kHz
 1 kHz - 10 kHz
 10 kHz - 100 kHz
 100 kHz - 1 MHz
 EXT

In the "EXT" position the instrument is triggered by a TTL pulse (0 to +5V) on the "EXT TRIG" connector.

(3) REPETITION RATE fine control. This varies the pulse repetition rate within the selected range.

(4) PULSE DELAY range switch. This controls the delay between the SYNC OUT output (see item 10) and the main OUT output (item 9). This switch selects one of the three delay ranges.

50 ns - 0.5 μ s
 0.5 μ s - 5 μ s
 5 μ s - 50 μ s

(5) PULSE DELAY fine control. This varies the delay within the selected range.

(6) PULSE WIDTH range switch. This selects one of three pulse width ranges:

0.05 μs - 0.5 μs

0.5 μs - 5 μs

5 μs - 50 μs

(7) PULSE WIDTH fine control. This varies the pulse width within the selected range.

(8) AMPLITUDE A fine control. This varies the output amplitude between 0 and +5 Volts.

(9) OUT connector. This connector provides the main output. It will supply up to +5V into 50 Ω . The output impedance is 50 Ω .

(10) SYNC OUT connector. This output supplies a TTL-level pulse (nominally) to trigger oscilloscopes or other measurement equipment. The output pulse width is nominally fixed at 50ns.

(11) MONITOR connector. This output provides +1V into 50 Ω (+4V into 1k Ω) with same delay, pulse width, and frequency as the main output. The amplitude of this output is completely independent of the amplitude of the main output.

(12) EXT TRIG connector. If the REPETITION RATE range switch (item 2) is in the "EXT" position, the instrument will be triggered by an external TTL-level trigger applied to this connector. Note that this is a high-impedance input; it is not terminated in 50 Ω . If the REPETITION RATE range switch is not in the "EXT" position, this input has no effect. However, it should be left unconnected to avoid electromagnetic interference with the internal clock.

(13) DUTY CYCLE OVERLOAD indicator. This LED indicator will light if the duty cycle exceeds 45%. If this light is on, the pulse generator has stopped triggering and the duty cycle should be reduced.

GENERAL INFORMATION

BASIC PULSE CONTROL

This pulse-delay generated can be triggered by its own internal clock or by an external TTL trigger signal. In either case, three output channels respond to the trigger: SYNC OUT, MONITOR, and OUT. The SYNC OUT pulse is a fixed-width pulse that is generated immediately after triggering. This pulse can be used to trigger oscilloscopes or other measurement systems. The two other output channels are referenced to the SYNC OUT pulse. This relationship is illustrated in Figure 4.

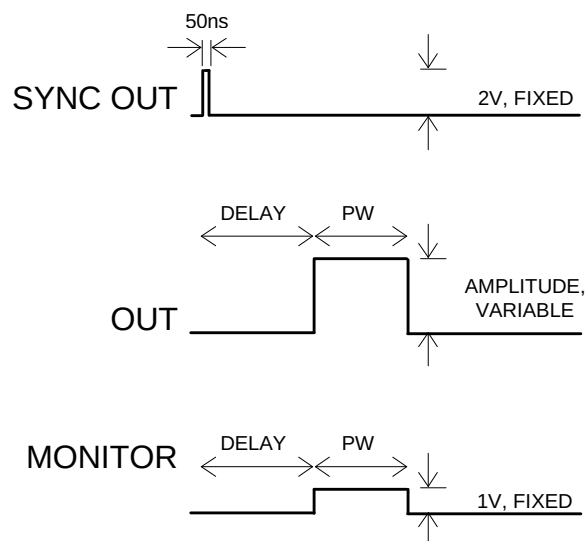

Figure 4 - Basic Output Pulses

The delay, pulse width, and amplitude parameters indicated in Figure 4, as well as the frequency, can be varied with front panel controls or via the GPIB computer interface.

This pulse generator incorporates a special duty cycle protection circuit, to prevent the output duty cycle (the pulse width divided by the period) from exceeding 45%. The instrument will stop triggering if the duty cycle exceeds 45%, and will not start triggering again until the duty cycle has been reduced. (To reduce the duty cycle, either the frequency or the pulse width must be decreased.) The "DUTY CYCLE OVERLOAD" indicator on the front panel will come on if the duty cycle limit has been exceeded.

ELECTROMAGNETIC INTERFERENCE

To prevent electromagnetic interference with other equipment, all used outputs should be connected to shielded 50 Ohm loads using shielded 50 Ohm coaxial cables. Unused outputs should be terminated with shielded 50 Ohm BNC terminators or with shielded BNC dust caps, to prevent unintentional electromagnetic radiation.

TOP AND BOTTOM COVER REMOVAL

The top cover of the instrument may be removed by removing the four Phillips screws on the top panel. With these four screws removed, the top panel may be slid off by pulling it towards the rear. The bottom panel may be similarly removed.

USER-ACCESSIBLE INTERNAL ADJUSTMENTS

Several trimming potentiometers are accessible inside the instrument to tweak the duty cycle protection circuit, and to null any voltage offsets present on the output waveform. These potentiometers are factory-set and should not normally require any adjusting. These controls can be accessed by removing the top panel, and by locating the large, horizontal board mounted on the left-side and the front panel of the instrument.

If an amplitude-independent offset is present on the output waveform, this can be nulled by adjusting the potentiometer labeled "OFFSET1". (The potentiometer may be obscured by a ribbon cable. Simple move the ribbon cable out of the way.) If an amplitude-dependent offset in excess of $\pm 20\text{mV}$ is present on the output waveform, this can be nulled by adjusting the potentiometer labeled "OFFSET2".

Three separate duty-cycle adjustment controls are present, and are labeled "DUTY1", "DUTY2", and "DUTY3". Each corresponds to a different pulse width range:

Adjust this control	to protect this PW range
DUTY1	0.05 μs - 0.5 μs
DUTY2	0.5 μs - 5 μs
DUTY3	5 μs - 50 μs

If the protection circuit is being triggered at duty cycles outside of the 43% - 47% range for one (or more) of the PW ranges, adjust the appropriate "DUTY" potentiometer(s).

USING THE GPIB INTERFACE

The AV-1022-C-AS4 incorporates the Avtech OP1 "GPIB bus listener interface". This section describes how to use the IEEE 488 General Purpose Interface Bus (GPIB) for remote computer control of the AV-1022-C-AS4.

INTERFACE TO THE GPIB

The Avtech OP1 interface is a simple "listener" interface for the GPIB. It will receive simple commands from a computer over the GPIB bus, but it does not have the capability to send any data back to the computer. In more concise terms, the OP1 interface implements the following IEEE 488.1 Capabilities as defined in the IEEE 488.1 Standard:

SH0	no "Source Handshake" capability (can not send information)
AH1	complete "Acceptor Handshake" capability (can receive information)
T0	no "Talk" capability (can not send information)
TE0	no "Talk Extended" capability (can not send information)
L2	basic "Listen" capability (can receive information)
LE0	no "Listen Extended" capability (because it is a basic listener only)
SR0	no "Service Request" capability (because it is a basic listener only)
RL0	"Remote/Local" switching controlled by a back panel switch (not computer controlled)
PP0	no "Parallel Poll" capability (because it is a basic listener only)
DC0	no "Device Clear" capability (can not be remotely reset)
DT0	no "Device Trigger" capability (can not be triggered by the computer)
C0	no "Controller" capability (because it is a basic listener only)

AVAILABLE COMMANDS

The OP1 GPIB user interface is designed to be used to remotely program the Avtech pulse generator to control the pulse repetition rate, delay, pulse width, and amplitude.

The available commands, outputs, units and range of acceptable values for the AV-1022-C-AS4 generator are defined in the table below:

Command Acronym	Function	Units	Range
V	set voltage	V	0 to 5
R	set repetition rate	Hz	100 to 1000000
W	set pulse width	μ S	0.05 to 50
D	set delay	μ S	0.05 to 50

COMMAND INTERPRETATION

The command may utilize the defined single letter acronym, or may be expanded to a longer word to make the control program easier to understand. This is because letters following the defined acronym letter are ignored. For example, a command of "V2" will cause exactly the same result if the command is sent as "Voltage level of output pulse = 2". However, it is mandatory that the first letter of each command be one of the four defined acronyms.

If desired, trailing text may be added to make the control program easier to understand, since it will be ignored. For example, a command of "delay=0.2" will result in the same output as the command "delay = 0.2 micro-seconds".

Acronyms are case insensitive, for example, "R" or "r" are the same.

The number following the acronym letter may be any number in the range specified, however, the number of significant digits are limited to one part in 255 (for 8 bits of output resolution). For example, rep rate values of 128.2, 128.3 or 128.2145 will all result in the same output. (Note that output resolution and accuracy are not necessarily the same). Numbers outside the specified ranges will be ignored.

Leading or trailing zeros in numbers will be ignored. Numbers expressed in "exponential" format will NOT be interpreted correctly. For example, 3e+2 will be interpreted as 3, not as 300.

If an invalid command is sent, the unit will ignore the command and the previous value will remain unchanged. If an "out-of-range" value is sent, the unit will also ignore the command.

TYPICAL COMMAND SEQUENCE INTERPRETATION

Assume the following commands are sent using the computer, using the appropriate command structure as specified for the user's GPIB controller. Note that the default GPIB address is eight.

```
R=100  
V=5  
D=1  
W=2
```

For example, for a GPIB controller from National Instruments, the following set of commands would be sent:

```
ibwrt "r=100"
ibwrt "v=5"
ibwrt "d=1"
ibwrt "w=2"
```

This command sequence will cause the generator to produce an output with a repetition rate of 100 Hz, delay of 1 μ s, pulse of width 2 μ s and an amplitude of 5 Volts.

SAMPLE PROGRAM

To illustrate the remote control process by means of the GPIB, a sample program written in BASIC is provided. While this example is prepared for use with the B&C MicroSystems PC488 circuit card, the general principles of control apply to any IEEE 488 GPIB Controller.

```
'TEST of Pulser Controller
OPEN "PC488" FOR OUTPUT AS #1
PRINT #1, "ABORT"
PRINT #1, "CLEAR"
PRINT #1, "OUTPUT 8;V", 5
PRINT #1, "OUTPUT 8;R", 100
PRINT #1, "OUTPUT 8;D",1
PRINT #1, "OUTPUT 8;W",2
END
```

CHANGING THE UNIT GPIB ADDRESS

The GPIB data bus address for the pulse generator has been preset to "8" in the factory. However, the user may wish to change the address to any address in the allowed range of 0 to 30. This address may be easily changed by re-setting the GPIB address switch on the GPIB Interface board located inside the pulse generator chassis.

The address is set by means of a five position "Dipswitch " located on the top of a small circuit card located inside the enclosure near the top rear. The switch may be observed to be set to the default address by noting that the Dipswitch position 4 is set in the OFF position, defining a binary address of 8.

The switch setting is calculated as the sum of the switch weights in the OFF position, calculated as follows: (a switch in the ON position it has a weight of zero):

Switch Number	OFF Weight
1	1
2	2
3	4
4	8
5	16

For example, a switch with positions 1, 4 and 5 set to OFF will result in an address setting of 25 (16 plus 8 plus 1 = 25).

TROUBLE-SHOOTING AID

In the event that difficulties are encountered communicating via the GPIB interface, two auxiliary communications status indicators have been included on the GPIB interface circuit card. These status indicators are small LED lamps, one which flashes briefly whenever a properly addressed command is received. The second LED will light whenever an out-of-range value or invalid command is received, and will remain lit until a valid command with a valid in-range value is subsequently received.

