

INSTRUCTIONS

MODEL AV-1023-C

DUAL-CHANNEL LAB
PULSE-DELAY GENERATOR

SERIAL NUMBER: _____

WARRANTY

Avtech Electrosystems Ltd. warrants products of its manufacture to be free from defects in material and workmanship under conditions of normal use. If, within one year after delivery to the original owner, and after prepaid return by the original owner, this Avtech product is found to be defective, Avtech shall at its option repair or replace said defective item. This warranty does not apply to units which have been disassembled, modified or subjected to conditions exceeding the applicable specifications or ratings. This warranty is the extent of the obligation assumed by Avtech with respect to this product and no other warranty or guarantee is either expressed or implied.

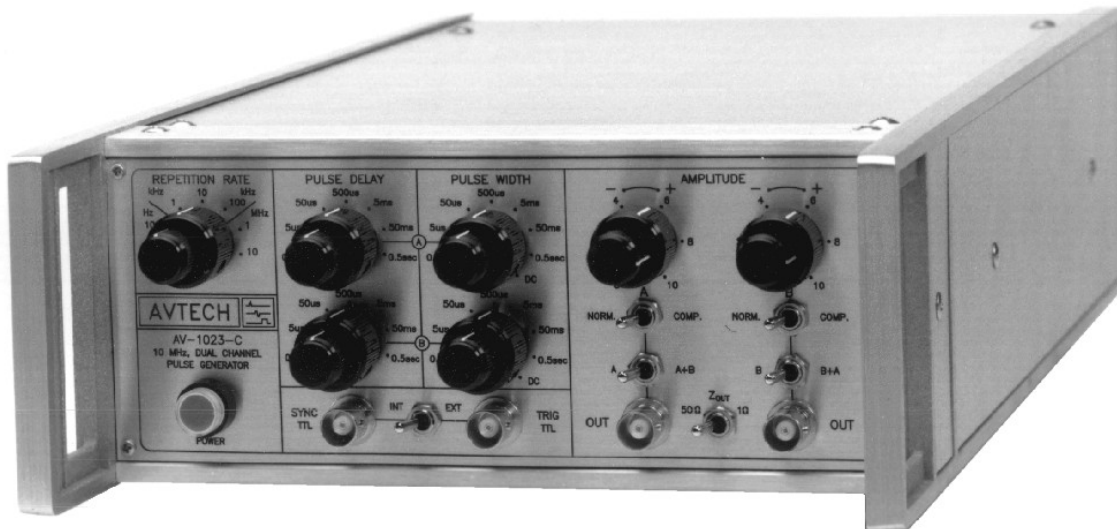

EC Declaration of Conformity

We

Avtech Electrosystems Ltd.
P.O. Box 5120, Stn. F
Ottawa, Ontario
Canada K2C 3H4

declare that the AV-1023-C pulse generator meets the intent of Directive 89/336/EEC for Electromagnetic Compatibility. Compliance pertains to the following specifications as listed in the official Journal of the European Communities:

EN 50081-1 Emission

EN 50082-1 Immunity



Fig. 1

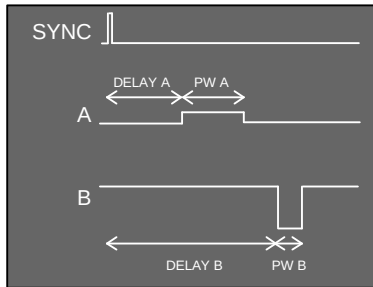

- Two channels with independent amplitudes, polarities, delays and pulse widths
- Outputs can be inverted, complemented, and added together
- ± 10 Volt outputs, 10 MHz
- 10 ns rise and fall times
- User-friendly front panel
- Extremely versatile
- Dual pulse generator, delay generator, and DC power supply all-in-one!

The versatile Model AV-1023-C is a 10 MHz dual-channel general-purpose lab pulse generator and delay generator providing 0 to ± 10 Volts, 10 ns rise time, variable pulse widths and delays, self-explanatory front panel controls and a heavy-duty metal chassis for low emissions and decades of trouble-free service.

Channels A and B share a common trigger source, but have independently controlled delays, pulse widths, polarities, and amplitudes (see Figure 1). The two output channels can be summed together, if desired. One output connector can supply either A or A+B, and the other can supply B or B+A. Two examples of summing are shown in Figure 2.

Fig. 2

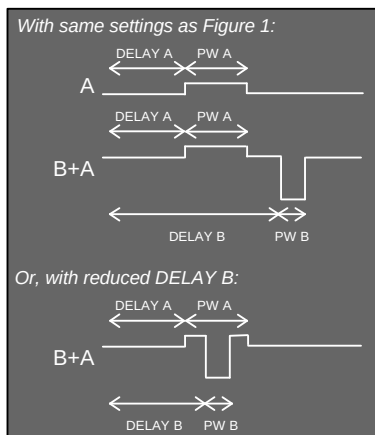

Number of channels out:	Two
Pulse Repetition Rate:	1 Hz to 10 MHz
Amplitude (to 50 Ohms):	0 to ± 10 V (± 5 V if $Z_{OUT} = 50 \Omega$)
Pulse width (PW):	50 ns to 0.5 sec
Rise time, fall time:	10 ns
DC offset:	0 to ± 10 Volts (± 5 V if $Z_{OUT} = 50 \Omega$) when used in summing mode with one channel's PW set at DC
Source impedance:	1 Ohm or 50 Ohms
Polarity:	Positive or negative
Duty cycle (max):	>80%, 100% if complemented 100% in PW DC mode
Overshoot, undershoot, ringing and slope aberration:	< $\pm 3\%$ at amplitudes of >300 mV with outputs terminated in 50 Ω .
Propagation delay:	80 ns to 0.5 sec (Ext trig in to pulse out)
Trigger required (Ext trig mode):	+ 5 Volts, ≥ 40 ns TTL
Sync delay, jitter:	35 ns to 0.5 sec, $\leq \pm 50$ ps or $\pm 0.05\%$ (sync out to pulse out)
Sync output:	+2 Volts, 50 ns, will drive 50 Ohm loads
Signal connectors:	BNC
Power requirement:	120/240 Volts (switchable) 50 - 60 Hz, 30 Watts
Dimensions (H x W x D):	100 mm x 215 mm x 315 mm (3.9" x 8.5" x 14.8")
Weight & chassis material:	4.5 kg (10 lbs), anodized aluminum, with blue-grey plastic trim
Mounting & Temperature range:	Any, $+10^\circ$ C to $+40^\circ$ C

The AV-1023-C can be triggered internally, with the frequency controlled by a 7-position range switch and a one-turn fine control, from 1Hz to 10MHz. The AV-1023-C can also be triggered externally by a TTL (0 to +5V) signal on the TRIG input. A SYNC output provides a narrow pulse to trigger oscilloscopes. The A and B channels are delayed relative to this SYNC output. The pulse widths and delays are variable from 50 ns to 0.5 sec and are controlled by 7-position range switches and one turn fine controls. The pulse widths may also be set to the "DC" mode, allowing each channel to act as a variable ± 10 Volt, 200 mA DC power supply, or to supply a DC offset when summed with the other channel.



Channels A and B may be polarity-inverted (i.e. from positive to negative voltages) or logic-complemented (i.e. high and low voltage levels reversed) to provide a wide variety of output waveforms.

The output impedance can be set at 50 Ω (for transmission-line backmatching) or at 1 Ω for maximum voltage output.

With this degree of versatility, the AV-1023-C is a general-purpose workhorse - perhaps the only pulser-delay generator that you'll ever need!

Fig. 3 demonstrates the versatility of the AV-1023-C, by showing the ease with which the waveforms for measuring semiconductor switching recovery times can be generated:

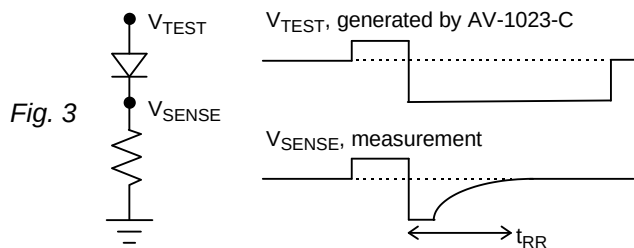

Model:	AV-1023-C
--------	-----------

INSTALLATION

VISUAL CHECK

After unpacking the instrument, examine to ensure that it has not been damaged in shipment. Visually inspect all connectors, knobs and the handles. Confirm that a power cord and instrumentation manual are with the instrument. (If the instrument has been damaged, file a claim immediately with the company that transported the instrument).

PLUGGING IN THE INSTRUMENT

Examine the rear of the instrument. There will be a male power receptacle, a fuse holder and the edge of the power selector card visible. Confirm that the power selector is in the correct orientation - it should be marked either 120 or 240, indicating whether it expects 120V AC or 240V AC. If it is not set for the proper voltage, remove the fuse and then grasp the card with a pair of pliers and remove it. Rotate horizontally through 180 degrees. Reinstall the card and the correct fuse. In the 120V setting, a 1/2A slow blow fuse is required. In the 240V setting, a 1/4A slow blow fuse is required.

OPERATIONAL CHECK

This check is to confirm that the instrument is fully operational. Set the controls to the following values:

- INT/EXT switch: INT position
- REPETITION RATE outer knob: 10 kHz position
- REPETITION RATE inner knob: fully clockwise (max. frequency)
- PULSE DELAY outer knobs, both A and B: 50us position
 - PULSE DELAY inner knobs, both A and B: fully counter-clockwise (minimum delay)
- PULSE WIDTH outer knobs, both A and B: 5us position
 - PULSE WIDTH inner knobs, both A and B: fully clockwise (maximum pulse width)
- AMPLITUDE outer knobs, both A and B: + position

- AMPLITUDE inner knobs, both A and B: fully clockwise (maximum amplitude)
- NORM/COMPL switches, both A and B: NORM (normal) position
- A/A+B switch: A position
- B/B+A switch: B position
 - Z_{OUT} switch: 1 Ω

Connect a 50 Ω coaxial cable from the SYNC connector to the TRIG input of an oscilloscope. Connect 50 Ω , 2 Watt loads to both OUT connectors. Connect the left OUT connector to one oscilloscope probe, and the right OUT connector to another. Position the oscilloscope trace of the left OUT connector above the other trace of the right OUT connector on the oscilloscope screen.

Set the oscilloscope to trigger externally with the vertical setting at 5 Volts/div and the horizontal setting at 20 μ s/div. Then follow the instructions below and compare what is seen on the oscilloscope to what is described. Only approximate values are needed to confirm operation.

<u>STEP</u>	<u>CONTROL</u>	<u>OPERATION</u>	<u>RESULTS</u>
1	POWER	Push in (on)	Nearly-identical +10V pulses at both outputs, with period 100 μ s, pulse width 5 μ s, and rise & fall times of 10 ns.
2	REPETITION RATE inner knob	Rotate fully counter-clockwise, then fully clockwise	Period rises to about 1ms, then falls back to 100 μ s.
3	PULSE DELAY inner knob A	Rotate fully clockwise, then fully counter-clockwise	The upper pulse shifts to the right on the oscilloscope by 50 μ s, then back
4	PULSE DELAY inner knob B	Rotate fully clockwise and leave it there	The lower pulse shifts to the right on the oscilloscope by 50 μ s

5	PULSE WIDTH inner knob A	Rotate fully counter-clockwise, then fully clockwise	The upper pulse narrows to 0.5 μ s, then widens back to 5 μ s.
6	PULSE WIDTH inner knob B	Rotate fully counter-clockwise, then fully clockwise	The lower pulse narrows to 0.5 μ s, then widens back to 5 μ s.
7	AMPLITUDE outer knob A	Switch to "-" position, then back to "+"	The upper pulse polarity becomes negative, then positive.
8	AMPLITUDE outer knob B	Switch to "-" position, then back to "+"	The lower pulse polarity becomes negative, then positive.
9	NORM/COMP A	Switch to "COMP", then back to "NORM"	The upper pulse becomes inverted, then non-inverted
10	NORM/COMP B	Switch to "COMP", then back to "NORM"	The lower pulse becomes inverted, then non-inverted
11	A/A+B	Switch to "A+B", then back to "A".	The upper trace becomes a double pulse, separated by 50 μ s, and then returns to a single pulse.
12	B/B+A	Switch to "B+A", then back to "B".	The lower trace becomes a double pulse, separated by 50 μ s, and then returns to a single pulse.

FRONT PANEL CONTROLS

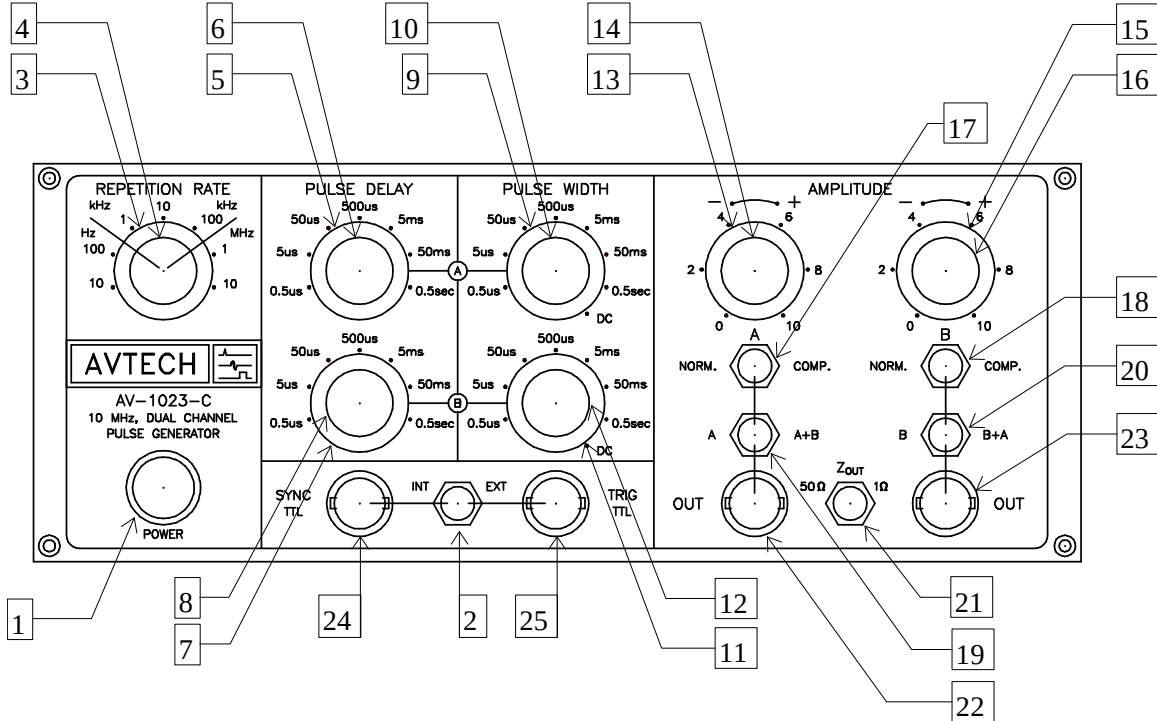

(1) POWER switch. The POWER pushbutton switch applies AC prime power to the primaries of the transformer, turning the instrument on.

(2) INT/EXT switch. In the "INT" position the instrument is internally triggered (i.e. the pulse repetition frequency is controlled by the REPETITION RATE front panel controls). In the "EXT" position the instrument is triggered by a TTL pulse (0 to +5V) on the "TRIG" connector.

(3) REPETITION RATE outer knob. This selects one of the seven pulse repetition rate ranges:

- 1 Hz - 10 Hz
- 10 Hz - 100 Hz
- 100 Hz - 1 kHz
- 1 kHz - 10 kHz
- 10 kHz - 100 kHz
- 100 kHz - 1 MHz
- 1 MHz - 10 MHz

(4) REPETITION RATE inner knob. This varies the pulse repetition rate within the selected range.

(5) PULSE DELAY A outer knob. This selects one of the seven delay ranges for channel "A":

- 0.05 μ s - 0.5 μ s
- 0.5 μ s - 5 μ s

5 μs - 50 μs
50 μs - 500 μs
500 μs - 5 ms
5 ms - 50 ms
50 ms - 0.5 sec

(6) PULSE DELAY A inner knob. This varies the channel "A" delay within the selected range.

(7) PULSE DELAY B outer knob. This selects one of the seven delay ranges for channel "B".

(8) PULSE DELAY B inner knob. This varies the channel "B" delay within the selected range.

(9) PULSE WIDTH A outer knob. This selects one of the seven pulse width ranges for channel "A":

0.05 μs - 0.5 μs
0.5 μs - 5 μs
5 μs - 50 μs
50 μs - 500 μs
500 μs - 5 ms
5 ms - 50 ms
50 ms - 0.5 sec
DC (i.e. constant output)

(10) PULSE WIDTH A inner knob. This varies the channel "A" pulse width within the selected range.

(11) PULSE WIDTH B outer knob. This selects one of the seven pulse width ranges for channel "B".

(12) PULSE WIDTH B inner knob. This varies the channel "B" pulse width within the selected range.

(13) AMPLITUDE A outer knob. This switch selects the output polarity (positive or negative) of channel "A".

(14) AMPLITUDE A inner knob. This varies the output amplitude of channel "A" between 0 and 10 Volts.

(15) AMPLITUDE B outer knob. This switch selects the output polarity (positive or negative) of channel "B".

(16) AMPLITUDE B inner knob. This varies the output amplitude of channel "B" between 0 and 10 Volts.

(17) NORM/COMP A switch. In the "NORM" position, channel "A" is logically non-inverted. In the "COMP" position, channel "A" is logically complemented (i.e. inverted). In the complemented state, the high and low voltage levels are reversed relative to the "NORM" state. The polarities do not change.

(18) NORM/COMP B switch. In the "NORM" position, channel "B" is logically non-inverted. In the "COMP" position, channel "B" is logically complemented (i.e. inverted). In the complemented state, the high and low voltage levels are reversed relative to the "NORM" state. The polarities do not change.

(19) A/A+B switch. In the "A" position, the leftmost OUT connector (item 22) outputs channel "A". In the "A+B" position, this connector provides the sum of channels "A" and "B" instead.

(20) B/B+A switch. In the "B" position, the rightmost OUT connector (item 23) outputs channel "B". In the "B+A" position, this connector provides the sum of channels "B" and "A" instead.

(21) Z_{OUT} switch. This switch sets the output impedance of the two main outputs (items 22 and 23). The output impedance can be 1Ω or 50Ω.

(22) OUT, left connector. This connector provides either "A" or "A+B" outputs, depending on this position of the A/A+B switch. The output impedance is set by the Z_{OUT} switch.

(23) OUT, right connector. This connector provides either "B" or "B+A" outputs, depending on this position of the B/B+A switch. The output impedance is set by the Z_{OUT} switch.

(24) SYNC connector. This output supplies a TTL-level pulse to trigger oscilloscopes or other measurement equipment. The output pulse width is nominally fixed at 50ns.

(25) TRIG connector. If the INT/EXT switch (item 2) is in the "EXT" position, the external TTL-level trigger should be applied to this input. When the INT/EXT switch is in the "INT" position, this input has no effect. However, it should be left unconnected to avoid electromagnetic interference with the internal clock.

GENERAL INFORMATION

BASIC PULSE CONTROL

This pulse-delay generated can be triggered by its own internal clock or by an external TTL trigger signal. In either case, three output channels respond to the trigger: SYNC, A, and B. The SYNC pulse is a fixed-width pulse that is generated immediately after triggering. This pulse can be used to trigger oscilloscopes or other measurement systems. The two main output channels, A and B, are referenced to the SYNC pulse. This relationship is illustrated in Figure 4.

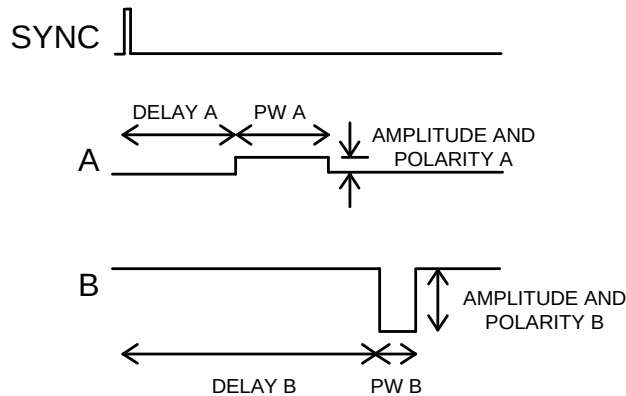

Figure 4 - Basic Output Pulses

Each of the parameters indicated in Figure 4 can be varied with a front panel control.

SUMMING OUTPUTS

The output connectors can supply A and B directly, or they can be added together, and the two output connectors can be used to supply two of A, B, or $A+B=B+A$. This allows complex waveforms to be constructed. Some examples are shown in Figure 5.

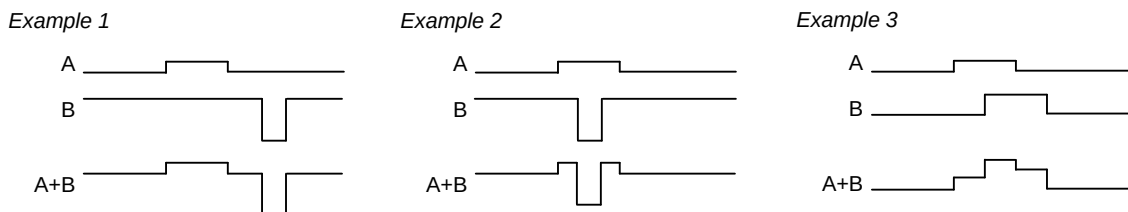

Figure 5

NORM/COMP MODES

The pulses of channels A and B may be of either polarity (i.e. positive or negative). In addition, the NORM/COMP switches allow pulses to be inverted logically - the high and low voltages can be swapped. This is illustrated in figure 6.

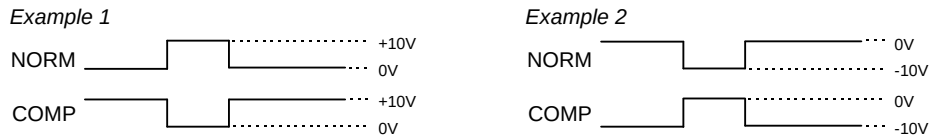

Figure 6

OUTPUT IMPEDANCE

The output impedance can be set to be 1Ω or 50Ω . The 50Ω position is useful for driving 50Ω transmission lines since this output impedance will provide back-matching, which suppresses transmission line reflections. Note however that when driving a 50Ω load with the switch in the 50Ω position will reduce the output voltage by a factor of 2, due to a voltage divider effect. The 1Ω position eliminates this voltage reduction.

ELECTROMAGNETIC INTERFERENCE

To prevent electromagnetic interference with other equipment, all used outputs should be connected to shielded 50 Ohm loads using shielded 50 Ohm coaxial cables. Unused outputs should be terminated with shielded 50 Ohm BNC terminators or with shielded BNC dust caps, to prevent unintentional electromagnetic radiation. All cords and cables should be less than 3m in length.

TOP AND BOTTOM COVER REMOVAL

The top cover of the instrument may be removed by removing the four Phillips screws on the top panel. With these four screws removed, the top panel may be slid off by pulling it towards the rear. The bottom panel may be similarly removed.