

INSTRUCTIONS

MODEL AV-1020-C

±10 V, 10 MHz LAB
PULSE-DELAY GENERATOR

SERIAL NUMBER: _____



EC Declaration of Conformity

We

Avtech Electrosystems Ltd.
P.O. Box 5120, Stn. F
Ottawa, Ontario
Canada K2C 3H4

declare that the AV-1020-C pulse generator meets the intent of Directive 89/336/EEC for Electromagnetic Compatibility. Compliance pertains to the following specifications as listed in the official Journal of the European Communities:

EN 50081-1 Emission

EN 50082-1 Immunity



WARRANTY

Avtech Electrosystems Ltd. warrants products of its manufacture to be free from defects in material and workmanship under conditions of normal use. If, within one year after delivery to the original owner, and after prepaid return by the original owner, this Avtech product is found to be defective, Avtech shall at its option repair or replace said defective item. This warranty does not apply to units which have been disassembled, modified or subjected to conditions exceeding the applicable specifications or ratings. This warranty is the extent of the obligation assumed by Avtech with respect to this product and no other warranty or guarantee is either expressed or implied.

TECHNICAL SUPPORT

Phone: 613-226-5772 or 1-800-265-6681

Fax: 613-226-2802 or 1-800-561-1970

E-mail: info@avtechpulse.com

World Wide Web: <http://www.avtechpulse.com>

TABLE OF CONTENTS

<i>EC Declaration of Conformity</i>	_____
WARRANTY	_____
TECHNICAL SUPPORT	_____
TABLE OF CONTENTS	_____
INTRODUCTION	_____
SPECIFICATIONS	_____
INSTALLATION	_____
VISUAL CHECK	_____
PLUGGING IN THE INSTRUMENT	_____
OPERATIONAL CHECK	_____
FRONT PANEL CONTROLS	_____
GENERAL INFORMATION	_____
BASIC PULSE CONTROL	_____
ELECTROMAGNETIC INTERFERENCE	_____
TOP AND BOTTOM COVER REMOVAL	_____

INTRODUCTION

The AV-1020-C is a general-purpose lab pulse-delay generator, which can generate waveforms of 0 to $\pm 10\text{V}$ in amplitude, with adjustable offset, into 50Ω loads at frequencies up to 10 MHz. The AV-1020-C has a 50Ω output impedance in its 1V and 5V ranges, and a 1Ω output impedance in its 10V range. The output rise and fall times are 10 ns. Inverted and non-inverted logic-level outputs are also provided, which can generate TTL or ECL levels into 50Ω loads. The AV-1020-C also features a single pulse pushbutton, a double pulse mode, a gating input, and a DC output mode.

The AV-1020-C can be triggered internally or by an external TTL signal.

SPECIFICATIONS

Model:	AV-1020-C
No. of channels out:	One, plus logic and logic-complement outputs
PRF:	1 Hz to 10 MHz
Amplitude (to 50 Ohms):	Main out: 0 to ± 10 Volts; TTL: 0 and +5V; ECL: -0.8V and -1.6V
Pulse width:	50 ns to 0.5 sec, or DC
Rise time, fall time:	Main: ≤ 10 ns, TTL: 5 ns, ECL: 2 ns
DC offset:	10 Volt range: 0 to ± 10 V; 1, 5 Volt range: 0 to ± 5 V
Source impedance (main output):	50 Ohms (1, 5 V ranges), 1 Ohm (10 V range)
Polarity (main output):	Positive or negative (two-position selector switch)
Duty cycle (max):	80% (100% in PW DC mode)
Waveform aberrations:	Overshoot, undershoot, ringing and slope aberration are less than $\pm 3\%$ at amplitudes of 300 mV and higher with outputs terminating in 50Ω .
Propagation delay:	70 ns to 0.5 sec (Ext trig in to pulse out)
Trigger required (Ext trig mode):	+5 Volts, ≥ 40 ns TTL
Trigger required (Gate in):	0 to 0.8 V: No output; +2.8 to +5 V (or open): normal out
Sync delay, jitter:	35 ns to 0.5 sec, $\leq \pm 50$ ps or $\pm 0.05\%$ (SYNC to pulse out)
SYNCput:	+2 Volts, 50 ns, will drive 50 Ohm loads
Single pulse mode:	manual push button
Signal connectors:	BNC
Power requirement:	120/240 Volts (switchable) 50 - 60 Hz (30 Watts)
Dimensions (H x W x D):	100 mm x 215 mm x 315 mm (3.9" x 8.5" x 14.8")
Chassis:	4.5 kg (10 lbs), anodized aluminum, with blue-grey plastic trim
Temperature range:	Any, $+10^\circ\text{C}$ to $+40^\circ\text{C}$

INSTALLATION

VISUAL CHECK

After unpacking the instrument, examine to ensure that it has not been damaged in shipment. Visually inspect all connectors, knobs and the handles. Confirm that a power cord and instrumentation manual are with the instrument. (If the instrument has been damaged, file a claim immediately with the company that transported the instrument).

PLUGGING IN THE INSTRUMENT

Examine the rear of the instrument. There will be a male power receptacle, a fuse holder and the edge of the power selector card visible. Confirm that the power selector is in the correct orientation - it should be marked either 120 or 240, indicating whether it expects 120V AC or 240V AC. If it is not set for the proper voltage, remove the fuse and then grasp the card with a pair of pliers and remove it. Rotate horizontally through 180 degrees. Reinstall the card and the correct fuse. In the 120V setting, a 1/2A slow blow fuse is required. In the 240V setting, a 1/4A slow blow fuse is required.

OPERATIONAL CHECK

This check is to confirm that the instrument is fully operational. Set the controls to the following values:

- INT/EXT switch: INT position
- SGL/DBL switch: SGL (single) position
- TTL/ECL switch: TTL position

- REPETITION RATE range switch: 100 kHz position
- REPETITION RATE fine control: fully counter-clockwise (minimum frequency)

- PULSE DELAY range switch: 50us position
- PULSE DELAY fine control: fully counter-clockwise (minimum delay)

- PULSE WIDTH range switch: 5us position
- PULSE WIDTH fine control: fully clockwise (maximum pulse width)

- BASELINE range switch: GND
- BASELINE fine control: mid-range

- AMPLITUDE range switch: 5V position
- AMPLITUDE fine control: fully clockwise (maximum amplitude)

- POLARITY switch: +

Connect a 50Ω coaxial cable from the SYNC connector to the TRIG input of an oscilloscope. Connect 50Ω, 2 Watt load between the OUT connector signal line and ground. Connect an oscilloscope probe to the main output.

Set the oscilloscope to trigger externally with the vertical setting at 2 Volts/div and the horizontal setting at 20 μs/div. Then follow the instructions below and compare what is seen on the oscilloscope to what is described. Only approximate values are needed to confirm operation.

STEP	CONTROL	OPERATION	RESULTS
1	POWER	Push in (on).	+5V pulses with period 100μs, pulse width 5μs, and rise & fall times of 10 ns.
2	PULSE DELAY fine control	Rotate fully clockwise	The pulses shift to the right on the oscilloscope by 50 μs
3	SGL/DBL switch	Switch to DBL, then back to SGL	A second pulse appears at the beginning of each period, then disappears.
4	PULSE DELAY fine control	Rotate fully counter-clockwise	The pulses shift to the left on the oscilloscope
5	PULSE WIDTH fine control	Rotate fully counter-clockwise, then fully clockwise	The pulses narrow to <0.5μs, then widen back to 5 μs.
6	REPETITION RATE fine control	Rotate fully clockwise, then fully counter-clockwise	The frequency rises to 100 kHz, then falls back to 10 kHz.
7	AMPLITUDE fine control	Rotate fully counter-clockwise, then fully clockwise	The pulse amplitude falls to 0 V, then rises back to +5 V.
8	POLARITY switch	Switch to "-"	Pulse amplitude switches from +5V to -5V.
9	BASE LINE switch and fine control	Switch to "VAR" and vary the fine control knob.	The waveform shifts up and down with a DC offset. The output voltages can not be higher than +5V or lower than -5V in this mode.
10	BASE LINE switch	switch to "GND"	The DC offset is removed.
11	PULSE WIDTH	Set to "DC"	Constant -5V DC output.

	range switch		(No pulsing).
12	PULSE WIDTH range switch	Set to "5 μ s"	-5V pulses with period 100 μ s, pulse width 5 μ s.
13	LOGIC connector	move the load and probe from the OUT connector to the LOGIC connector	+5V pulses with period 100 μ s, pulse width 5 μ s.
14	TTL/ECL switch	Switch to "ECL"	Pulses between -1.6V and -0.8V with period 100 μ s, pulse width 5 μ s.

Steps 1 to 14 confirm that the pulse delay, pulse width, amplitude controls, and the signal outputs are functioning properly.

Step 15 is optional, and is to confirm that the instrument can be triggered externally. First connect a pulse generator or other signal source with a 20 kHz frequency, a pulse width of at least 40ns, and TTL logic levels (0 and 5V) to the TRIG input connector. (The voltage applied to this input must not go below zero volts, or exceed +5V.) Then proceed with step 15:

15	INT/EXT switch	Set at "EXT"	Pulses between -1.6V and -0.8V with period 50 μ s, pulse width 5 μ s.
----	----------------	--------------	---

This completes the operational check.

FRONT PANEL CONTROLS

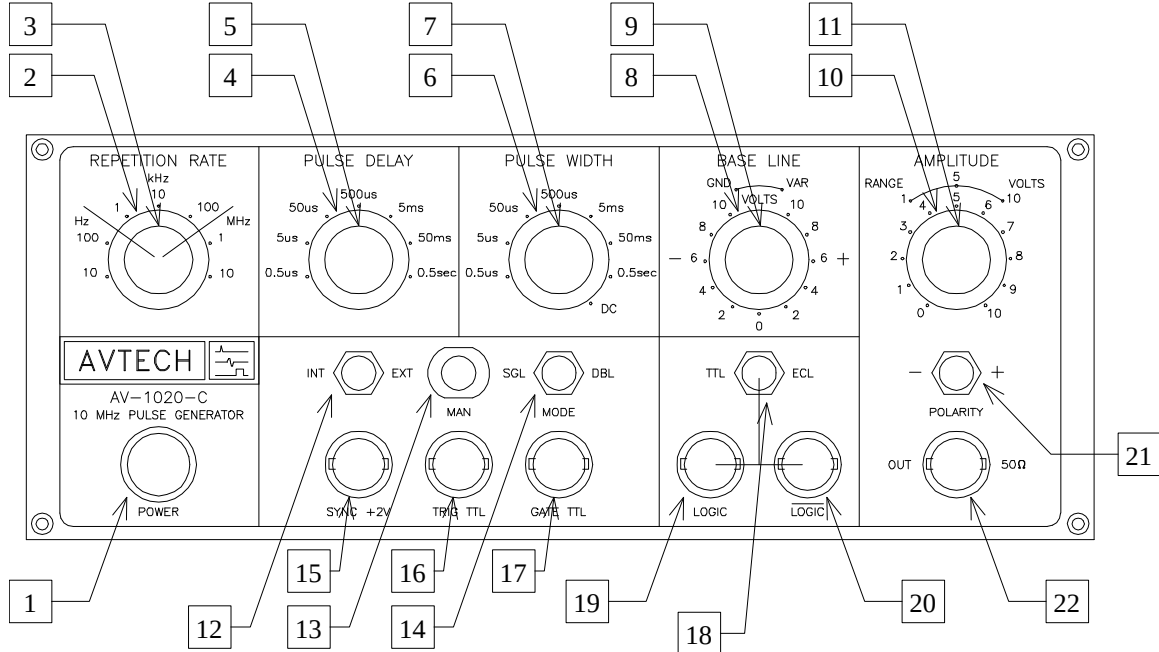

(1) POWER switch. The POWER pushbutton switch applies AC prime power to the primaries of the transformer, turning the instrument on.

(2) REPETITION RATE range switch. This selects one of the seven internal clock pulse repetition rate ranges:

1 Hz - 10 Hz
 10 Hz - 100 Hz
 100 Hz - 1 kHz
 1 kHz - 10 kHz
 10 kHz - 100 kHz
 100 kHz - 1 MHz
 1 MHz - 10 MHz

(3) REPETITION RATE fine control. This varies the pulse repetition rate within the selected range.

(4) PULSE DELAY range switch. This controls the delay between the SYNC output (see item 15) and the other outputs (items 19, 20, and 22). This switch selects one of the seven delay ranges.

50 ns - 0.5 μ s
 0.5 μ s - 5 μ s
 5 μ s - 50 μ s

50 μ s - 500 μ s
 500 μ s - 5 ms
 5 ms - 50 ms
 50 ms - 0.5 s

(5) PULSE DELAY fine control. This varies the delay within the selected range.

(6) PULSE WIDTH range switch. This selects one of eight pulse width ranges:

50 ns - 0.5 μ s
 0.5 μ s - 5 μ s
 5 μ s - 50 μ s
 50 μ s - 500 μ s
 500 μ s - 5 ms
 5 ms - 50 ms
 50 ms - 0.5 s
 DC

When set to the "DC" position, the output waveform is a constant DC voltage (i.e. there is no pulsing).

(7) PULSE WIDTH fine control. This varies the pulse width within the selected range. This control has no effect in the DC mode.

(8) BASE LINE switch. When this switch is set at "GND", the waveform on the OUT connector (22) has no offset voltage. (i.e., the waveform swings between 0V and the set amplitude). When this switch is set at "VAR", a variable offset (controlled by (9)) is added to the main output.

(9) BASE LINE fine control. When (8) is set at "VAR", this controls the offset added to the output waveform on (22).

(10) AMPLITUDE range switch. This selects one of three amplitude ranges:

0 to ± 1 V (50 Ω output impedance)
 0 to ± 5 V (50 Ω output impedance)
 0 to ± 10 V (1 Ω output impedance)

(11) AMPLITUDE fine control. This varies the magnitude of the output amplitude within the selected range.

(12) INT/EXT Switch. When in the "INT" position, the pulse generator is triggered by its internal clock, which is controlled by (2) and (3). In the "EXT" position, the pulse generator is triggered by a TTL-level signal on connector (16) or by the manual pushbutton (13).

(13) MAN pushbutton. If the INT/EXT switch is in the "EXT" position, pushing this button will generate a single pulse on the outputs.

(14) SGL/DBL switch. When this switch is in the "SGL" (single) position, a single pulse is generated each time the pulse generator is triggered. This pulse lags the pulse on the SYNC output (15) by a delay time set by controls (4) and (5). When in the "DBL" (double) position, two pulses are generated each time the pulse generator is triggered. The first pulse is (approximately) coincident with the SYNC pulse, and the second pulse lags the SYNC pulse by a delay time set by controls (4) and (5).

(15) SYNC connector. This output supplies a narrow TTL-level pulse (nominally) to trigger oscilloscopes or other measurement equipment.

(16) TRIG connector. If the INT/EXT switch (12) is in the "EXT" position, the instrument will be triggered by an external TTL-level trigger applied to this connector. Note that this input is terminated in 50Ω. If the INT/EXT switch is not in the "EXT" position, this input has no effect. However, it should be left unconnected to avoid electromagnetic interference with the internal clock.

(17) GATE connector. When this input is unconnected or is TTL high (+5V), the pulse generator triggers normally. When this input is TTL low (0V), further triggering is suppressed.

(18) TTL/ECL switch. This selects the logic levels used on the logic outputs (19) and (20). TTL levels are nominally 0 (low) and +5V (high), ECL levels are nominally -1.6V (low) and -0.8V (high).

(19) LOGIC output connector. This output has nominally the same delay and pulse width as the main output (22), but the voltage levels are preset by the TTL/ECL switch (18).

(20) LOGIC complement output connector. This output has nominally the same delay and pulse width as the main output (22), but the voltage levels are preset by the TTL/ECL switch (18). This output is inverted relative to (19), i.e. the high and low voltages are switched.

(21) POLARITY switch. This controls the polarity (+ or -) of the output waveform.

(22) OUT connector. This connector provides the main output. It will supply up to ±10V into 50Ω.

GENERAL INFORMATION

BASIC PULSE CONTROL

This pulse-delay generator can be triggered by its own internal clock or by an external TTL trigger signal. In either case, four output channels respond to the trigger: SYNC, OUT, and the two logic-level outputs. The SYNC pulse is a fixed-width pulse that is generated immediately after triggering. This pulse can be used to trigger oscilloscopes or other measurement systems. The other output channels are referenced to the SYNC pulse. This relationship is illustrated below, for the single pulse mode:

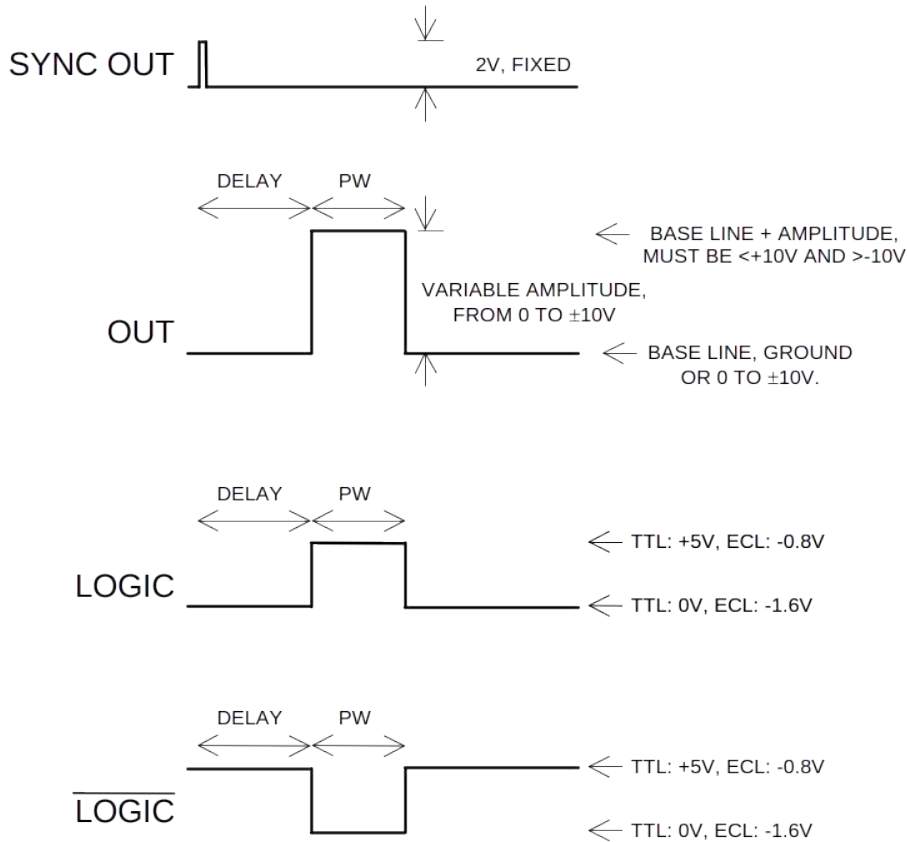

Basic Output Pulses in the Single Pulse Mode

If the "SGL/DBL" switch is in the "DBL" position, a double pulse is generated - a second pulse occurs, approximately coincident with the SYNC pulse. This is illustrated below:

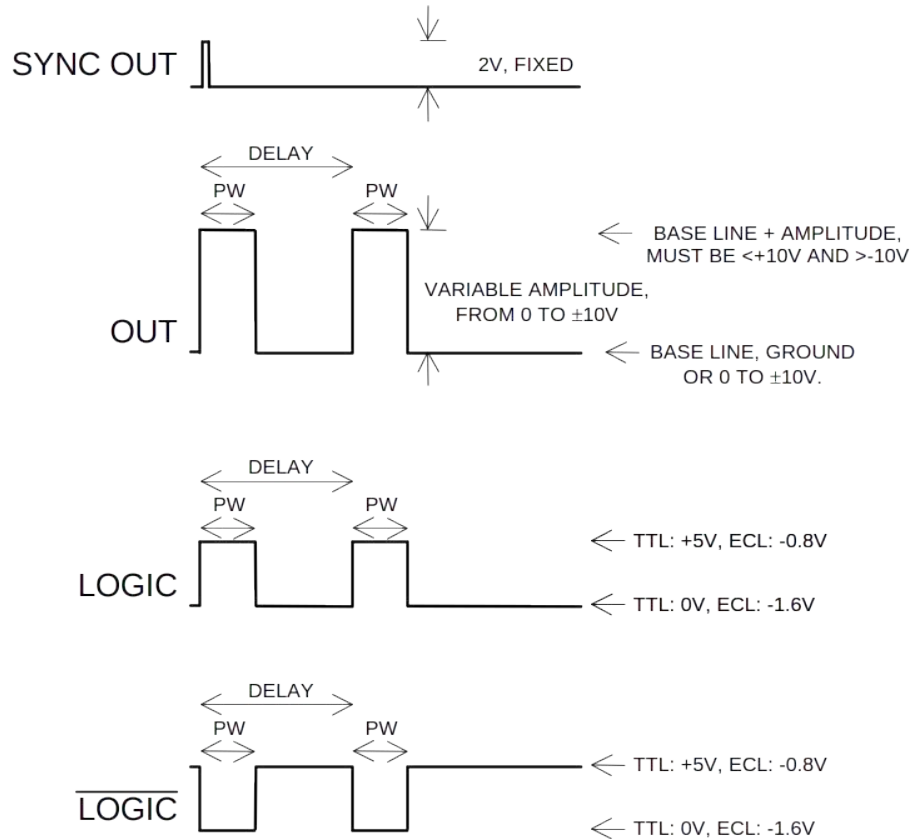

Basic Output Pulses in the Double Pulse Mode

ELECTROMAGNETIC INTERFERENCE

To prevent electromagnetic interference with other equipment, all used outputs should be connected to shielded 50 Ohm loads using shielded 50 Ohm coaxial cables. Unused outputs should be terminated with shielded 50 Ohm BNC terminators or with shielded BNC dust caps, to prevent unintentional electromagnetic radiation.

TOP AND BOTTOM COVER REMOVAL

The top cover of the instrument may be removed by removing the four Phillips screws on the top panel. With these four screws removed, the top panel may be slid off by pulling it towards the rear. The bottom panel may be similarly removed.