

INSTRUCTIONS

MODEL AV-1022-C

± 5 V, 10 MHz LAB
PULSE-DELAY GENERATOR

SERIAL NUMBER: _____

WARRANTY

Avtech Electrosystems Ltd. warrants products of its manufacture to be free from defects in material and workmanship under conditions of normal use. If, within one year after delivery to the original owner, and after prepaid return by the original owner, this Avtech product is found to be defective, Avtech shall at its option repair or replace said defective item. This warranty does not apply to units which have been disassembled, modified or subjected to conditions exceeding the applicable specifications or ratings. This warranty is the extent of the obligation assumed by Avtech with respect to this product and no other warranty or guarantee is either expressed or implied.

TECHNICAL SUPPORT

Phone: 613-226-5772 or 1-800-265-6681

Fax: 613-226-2802 or 1-800-561-1970

E-mail: info@avtechpulse.com

World Wide Web: <http://www.avtechpulse.com>

TABLE OF CONTENTS

WARRANTY	ii
TECHNICAL SUPPORT	ii
TABLE OF CONTENTS	iii
INTRODUCTION	1
SPECIFICATIONS	1
INSTALLATION	2
VISUAL CHECK	2
PLUGGING IN THE INSTRUMENT	2
OPERATIONAL CHECK	3
FRONT PANEL CONTROLS	5
GENERAL INFORMATION	7
BASIC PULSE CONTROL	7
ELECTROMAGNETIC INTERFERENCE	7
TOP AND BOTTOM COVER REMOVAL	7

Manual Reference: /filesserver1/officefiles/instructword/av-1020/av-1022-c,edition2.doc, created December 4, 2002

INTRODUCTION

The AV-1022-C is a general-purpose lab pulse-delay generator, which can generate waveforms of 0 to ± 5 V in amplitude, at frequencies up to 10 MHz. The AV-1022-C will drive 50 Ω loads, and has a 50 Ω output impedance. The output rise and fall times are 10 ns or less.

The AV-1022-C can be triggered internally or by an external TTL signal.

SPECIFICATIONS

Model:	AV-1022-C
No. of channels out:	One
PRF:	1 Hz to 10 MHz
Amplitude (to 50 Ohms):	0 to ± 5 Volts
Pulse width:	50 ns to 0.5 sec, or DC
Rise time, fall time:	≤ 10 ns
Source impedance (main output):	50 Ohms
Polarity (main output):	Positive or negative (two-position selector switch)
Duty cycle (max):	80% (100% in PW DC mode)
Waveform aberrations:	Overshoot, undershoot, ringing and slope aberration are less than $\pm 3\%$ at amplitudes of 300 mV and higher with outputs terminating in 50 Ω .
Propagation delay:	130 ns to 0.5 sec
Trigger required (Ext trig mode):	+ 5 Volts ≥ 25 ns TTL
Sync delay, jitter:	35 ns to 0.5 sec, $\leq \pm 50$ ps or $\pm 0.05\%$ (sync out to pulse out)
Sync output:	+2 Volts, 50 ns, will drive 50 Ohm loads
Single pulse mode:	manual push button
Signal connectors:	BNC
Power requirement:	120/240 Volts (switchable) 50 - 60 Hz (30 Watts)
Dimensions (H x W x D):	100 mm x 215 mm x 315 mm (3.9" x 8.5" x 14.8")
Weight & chassis material:	4.5 kg (10 lbs), anodized aluminum, with blue-grey plastic trim
Mounting & Temperature range:	Any, +10° C to +40° C

INSTALLATION

VISUAL CHECK

After unpacking the instrument, examine to ensure that it has not been damaged in shipment. Visually inspect all connectors, knobs and the handles. Confirm that a power cord and instrumentation manual are with the instrument. (If the instrument has been damaged, file a claim immediately with the company that transported the instrument).

PLUGGING IN THE INSTRUMENT

Examine the rear of the instrument. There will be a male power receptacle, a fuse holder and the edge of the power selector card visible. Confirm that the power selector card is in the correct orientation.

For AC line voltages of 110-120V, the power selector card should be installed so that the "120" marking is visible from the rear of the instrument, as shown below:

For AC line voltages of 220-240V, the power selector card should be installed so that the "240" marking is visible from the rear of the instrument, as shown below:

If it is not set for the proper voltage, remove the fuse and then grasp the card with a pair of pliers and remove it. Rotate horizontally through 180 degrees. Reinstall the card and the correct fuse.

In the 120V setting, a 1/4A slow blow fuse is required. In the 240V setting, a 1/8A slow blow fuse is required.

OPERATIONAL CHECK

This check is to confirm that the instrument is fully operational. Set the controls to the following values:

- REPETITION RATE range switch: 100 kHz position
- REPETITION RATE fine control: fully counter-clockwise (minimum frequency)

- PULSE DELAY range switch: 50us position
- PULSE DELAY fine control: fully counter-clockwise (minimum delay)

- PULSE WIDTH range switch: 5us position
- PULSE WIDTH fine control: fully clockwise (maximum pulse width)

- AMPLITUDE control: fully clockwise (maximum amplitude)

- POLARITY switch: +

Connect a 50 Ω coaxial cable from the SYNC OUT connector to the TRIG input of an oscilloscope. Connect 50 Ω , 2 Watt load between the OUT connector signal line and ground. Connect an oscilloscope probe to the main output.

Set the oscilloscope to trigger externally with the vertical setting at 2 Volts/div and the horizontal setting at 20 μ s/div. Then follow the instructions below and compare what is seen on the oscilloscope to what is described. Only approximate values are needed to confirm operation.

STEP	CONTROL	OPERATION	RESULTS
1	POWER	Push in (on).	+5V pulses with period 100 μ s, pulse width 5 μ s, and rise & fall times of 10 ns.
2	PULSE DELAY fine control	Rotate fully clockwise, then fully counter-clockwise	The pulses shift to the right on the oscilloscope by 50 μ s, then back
3	PULSE WIDTH fine control	Rotate fully counter-clockwise, then fully clockwise	The pulses narrow to <0.5 μ s, then widen back to 5 μ s.
4	REPETITION	Rotate fully	The frequency rises to 100

	RATE fine control	clockwise, then fully counter-clockwise	kHz, then falls back to 10 kHz.
5	AMPLITUDE fine control	Rotate fully counter-clockwise, then fully clockwise	The pulse amplitude falls to 0 V, then rises back to +5 V.
6	POLARITY switch	Switch to "-"	Pulse amplitude switches from +5V to -5V.
7	PULSE WIDTH range switch	Set to "DC"	Constant -5V DC output. (No pulsing).

Steps 1 to 7 confirm that the pulse delay, pulse width, and amplitude controls are functioning properly.

Step 8 is optional, and is to confirm that the instrument can be triggered externally. First connect a pulse generator or other signal source with a 10 kHz frequency, a pulse with of at least 40ns, and TTL logic levels (0 and 5V) to the EXT TRIG input connector. (The voltage applied to this input must not go below zero volts, or exceed +5V.) Then proceed with step 8:

8	REPETITION RATE range switch	Set at "EXT"	+5V pulses with period 100 μ s, pulse width 5 μ s, and rise & fall times of 10 ns.
---	------------------------------	--------------	--

This completes the operational check.

FRONT PANEL CONTROLS

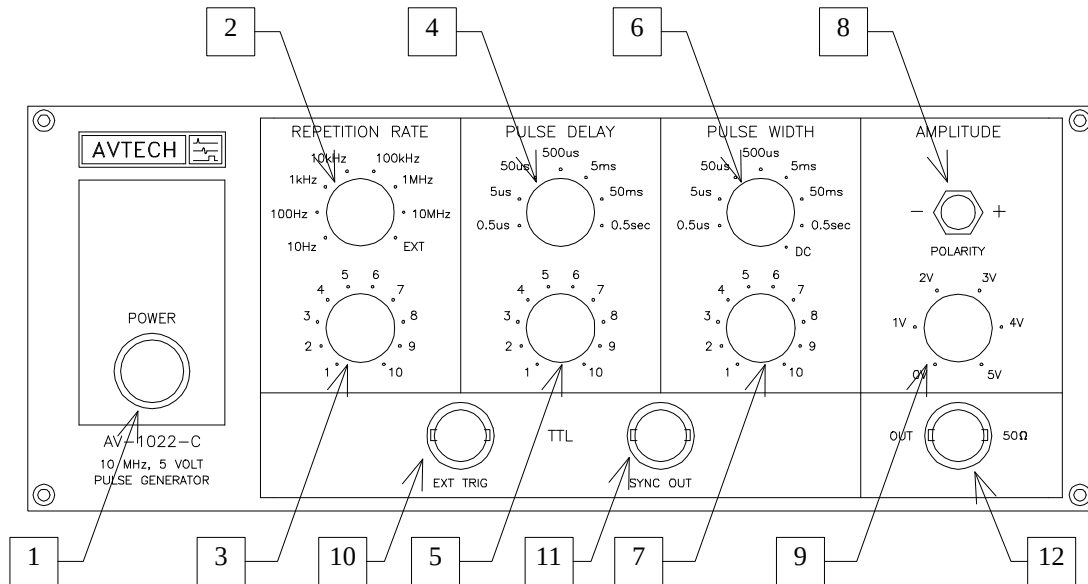

(1) POWER switch. The POWER pushbutton switch applies AC prime power to the primaries of the transformer, turning the instrument on.

(2) REPETITION RATE range switch. This selects one of the seven internal clock pulse repetition rate ranges, or the external triggering mode:

1 Hz - 10 Hz
 10 Hz - 100 Hz
 100 Hz - 1 kHz
 1 kHz - 10 kHz
 10 kHz - 100 kHz
 100 kHz - 1 MHz
 1 MHz - 10 MHz
 EXT

In the "EXT" position the instrument is triggered by a TTL pulse (0 to +5V) on the "EXT TRIG" connector.

(3) REPETITION RATE fine control. This varies the pulse repetition rate within the selected range.

(4) PULSE DELAY range switch. This controls the delay between the SYNC OUT output (see item 11) and the main OUT output (item 12). This switch selects one of the seven delay ranges.

50 ns - 0.5 μ s
 0.5 μ s - 5 μ s

5 μ s - 50 μ s
 50 μ s - 500 μ s
 500 μ s - 5 ms
 5 ms - 50 ms
 50 ms - 0.5 s

(5) PULSE DELAY fine control. This varies the delay within the selected range.

(6) PULSE WIDTH range switch. This selects one of eight pulse width ranges:

50 ns - 0.5 μ s
 0.5 μ s - 5 μ s
 5 μ s - 50 μ s
 50 μ s - 500 μ s
 500 μ s - 5 ms
 5 ms - 50 ms
 50 ms - 0.5 s
 DC

When set to the "DC" position, the output waveform is a constant DC voltage (i.e. there is no pulsing).

(7) PULSE WIDTH fine control. This varies the pulse width within the selected range. This control has no effect in the DC mode.

(8) POLARITY switch. This controls the polarity (+ or -) of the output waveform.

(9) AMPLITUDE fine control. This varies the magnitude of the output amplitude between 0 and 5 Volts.

(9) OUT connector. This connector provides the main output. It will supply up to +5V into 50 Ω . The output impedance is 50 Ω .

(10) EXT TRIG connector. If the REPETITION RATE range switch (item 2) is in the "EXT" position, the instrument will be triggered by an external TTL-level trigger applied to this connector. Note that this input is terminated in 50 Ω . If the REPETITION RATE range switch is not in the "EXT" position, this input has no effect. However, it should be left unconnected to avoid electromagnetic interference with the internal clock.

(11) SYNC OUT connector. This output supplies a TTL-level pulse (nominally) to trigger oscilloscopes or other measurement equipment. The output pulse width is nominally fixed at 50ns.

GENERAL INFORMATION

BASIC PULSE CONTROL

This pulse-delay generated can be triggered by its own internal clock or by an external TTL trigger signal. In either case, two output channels respond to the trigger: SYNC OUT and OUT. The SYNC OUT pulse is a fixed-width pulse that is generated immediately after triggering. This pulse can be used to trigger oscilloscopes or other measurement systems. The main output channel is referenced to the SYNC OUT pulse. This relationship is illustrated below:

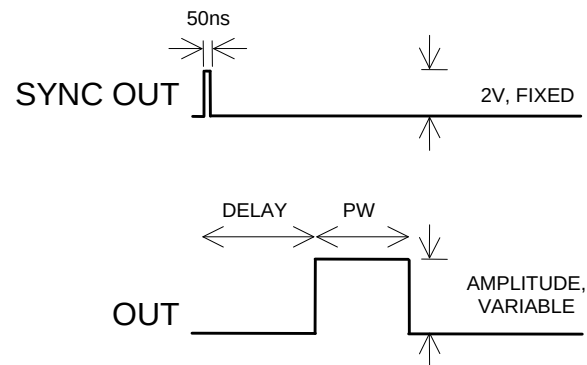

Basic Output Pulses

The delay, pulse width, and amplitude parameters can be varied with front panel controls.

ELECTROMAGNETIC INTERFERENCE

To prevent electromagnetic interference with other equipment, all used outputs should be connected to shielded 50 Ohm loads using shielded 50 Ohm coaxial cables. Unused outputs should be terminated with shielded 50 Ohm BNC terminators or with shielded BNC dust caps, to prevent unintentional electromagnetic radiation.

TOP AND BOTTOM COVER REMOVAL

The top cover of the instrument may be removed by removing the four Phillips screws on the top panel. With these four screws removed, the top panel may be slid off by pulling it towards the rear. The bottom panel may be similarly removed.