



AVTECH ELECTROSYSTEMS LTD.

NANOSECOND WAVEFORM ELECTRONICS
SINCE 1975

info@avtechpulse.com
<http://www.avtechpulse.com/>

Tel: 888-670-8729 (USA & Canada) or +1-613-686-6675 (Intl)
Fax: 800-561-1970 (USA & Canada) or +1-613-686-6679 (Intl)

BOX 5120, LCD MERIVALE
OTTAWA, CANADA K2C3H5

INSTRUCTIONS

MODEL AV-1023-C

±10 VOLT, 10 MHz

DUAL-CHANNEL

GENERAL PURPOSE PULSE GENERATOR

SERIAL NUMBER: 13964

WARRANTY

Avtech Electrosystems Ltd. warrants products of its manufacture to be free from defects in material and workmanship under conditions of normal use. If, within one year after delivery to the original owner, and after prepaid return by the original owner, this Avtech product is found to be defective, Avtech shall at its option repair or replace said defective item. This warranty does not apply to units which have been disassembled, modified or subjected to conditions exceeding the applicable specifications or ratings. This warranty is the extent of the obligation assumed by Avtech with respect to this product and no other warranty or guarantee is either expressed or implied.

TECHNICAL SUPPORT

Phone: 888-670-8729 (USA & Canada) or +1-613-686-6675 (International)

Fax: 800-561-1970 (USA & Canada) or +1-613-686-6679 (International)

E-mail: info@avtechpulse.com

World Wide Web: <http://www.avtechpulse.com>

TABLE OF CONTENTS

WARRANTY.....	2
TECHNICAL SUPPORT.....	2
TABLE OF CONTENTS.....	3
INTRODUCTION.....	5
SPECIFICATIONS.....	6
REGULATORY NOTES.....	7
FCC PART 18.....	7
EC DECLARATION OF CONFORMITY.....	7
DIRECTIVE 2011/65/EU (RoHS).....	8
DIRECTIVE 2002/96/EC (WEEE).....	8
INSTALLATION.....	10
VISUAL CHECK.....	10
POWER RATINGS.....	10
CONNECTION TO THE POWER SUPPLY.....	10
PROTECTION FROM ELECTRIC SHOCKS.....	11
ENVIRONMENTAL CONDITIONS.....	12
FUSES.....	13
AC FUSE REPLACEMENT.....	13
DC FUSE REPLACEMENT.....	14
FUSE RATINGS.....	14
FRONT PANEL CONTROLS.....	15
REAR PANEL CONTROLS.....	18
GENERAL INFORMATION.....	19
BASIC PULSE CONTROL.....	19
SUMMING OUTPUTS.....	20
OUTPUT IMPEDANCE.....	21
MINIMIZING WAVEFORM DISTORTIONS.....	22
USE 50Ω TRANSMISSION LINES.....	22
USE LOW-INDUCTANCE LOADS.....	22
MECHANICAL INFORMATION.....	23
TOP COVER REMOVAL.....	23
ELECTROMAGNETIC INTERFERENCE.....	23

- MAINTENANCE..... 24**
 - REGULAR MAINTENANCE..... 24
 - CLEANING..... 24
- WIRING DIAGRAMS..... 25**
 - WIRING OF AC POWER..... 25
 - PCB 158R4 - LOW VOLTAGE POWER SUPPLY..... 26
 - PCB 134B - MAIN BOARD..... 27
 - PCB 134B - MAIN BOARD - DC POWER..... 28
 - PCB 134B - MAIN BOARD - OSCILLATOR..... 29
 - PCB 134B - MAIN BOARD - TIMING A..... 30
 - PCB 134B - MAIN BOARD - TIMING B..... 31
 - PCB 134B - MAIN BOARD - AMPLITUDE A..... 32
 - PCB 134B - MAIN BOARD - AMPLITUDE B..... 33
 - PCB 134B - MAIN BOARD - FRONT PANEL..... 34
- PERFORMANCE CHECK SHEET..... 35**

Manual Reference: /files/server1/officefiles/instructword/av-1020/av-1023-c,ed4.odt.
Last modified February 29, 2024.
Copyright © 2024 Avtech Electrosystems Ltd, All Rights Reserved.

INTRODUCTION

The Avtech AV-1023-C is a versatile, general-purpose, low-cost, dual-channel 10 MHz laboratory pulse generator, useful everywhere from undergraduate university classrooms to the most advanced research and development laboratories. This pulse generator features variable pulse repetition frequency (PRF), delays, pulse widths, and amplitudes.

The generator can be triggered internally or externally. The internal trigger is continuously variable from 1 Hz to 10 MHz. The delays and pulse widths are variable up to 500 ms. The amplitudes are variable up to $\pm 10V$. Rise and fall times less than 10 ns (20%-80%).

The two main outputs ("A" and "B") have all of their characteristics variable, and are designed to drive 50Ω loads. A synchronizing trigger output ("SYNC") is also supplied, for triggering oscilloscopes and other test equipment (50 ns wide, +2V into 50Ω).

The two output channels can be summed together, if desired. One output connector can supply either A or A+B, and the other can supply B or B+A.

This instrument is intended for use in research and development laboratories by qualified personnel.

SPECIFICATIONS

Model:	AV-1023-C
Number of channels out:	Two
Pulse Repetition Rate:	1 Hz to 10 MHz
Amplitude (to 50 Ohms):	0 to ± 10 V (± 5 V if $Z_{OUT} = 50 \Omega$)
Pulse width (FWHM):	50 ns to 0.5 sec
Rise & fall times (20%-80%):	≤ 10 ns
DC offset:	0 to ± 10 Volts (± 5 V if $Z_{OUT} = 50 \Omega$) when used in summing mode with one channel's PW set at "DC"
Source impedance:	1 Ohm or 50 Ohms
Polarity:	Positive or negative
Duty cycle (maximum) ¹ :	0 - 3 MHz: 80%, 3 - 5 MHz: 70%, 5 - 10 MHz: 50%, 100% in PW DC mode
Overshoot, undershoot, ringing and slope aberration:	$< \pm 3\%$ at amplitudes of >300 mV with outputs terminated in 50Ω .
Propagation delay:	80 ns to 0.5 sec (Ext trig in to pulse out)
Trigger required (Ext trig mode):	+ 5 Volts, > 40 ns (TTL) Trig input impedance: $1 \text{ k } \Omega$
Sync delay, jitter:	35 ns to 0.5 sec, $\leq \pm 50$ ps or $\pm 0.05\%$ (sync out to pulse out)
Sync output:	+2 Volts, 50 ns, will drive 50 Ohm loads
Signal connectors:	BNC
Power requirement:	100 - 240 Volts, 50 - 60 Hz
Dimensions (H x W x D):	100 mm x 430 mm x 375 mm (3.9" x 17" x 14.8")
Chassis material:	Anodized aluminum, with blue-grey plastic trim
Temperature range:	+5°C to +40°C
Rack-mount kit:	Optional. Specify -R5 option.

1)The outputs can be logically-complemented, effectively extending the duty cycle range.

REGULATORY NOTES

FCC PART 18

This device complies with part 18 of the FCC rules for non-consumer industrial, scientific and medical (ISM) equipment.

This instrument is enclosed in a rugged metal chassis and uses a filtered power entry module (where applicable). The main output signal is provided on a shielded connector that is intended to be used with shielded coaxial cabling and a shielded load. Under these conditions, the interference potential of this instrument is low.

If interference is observed, check that appropriate well-shielded cabling is used on the output connectors. Contact Avtech (info@avtechpulse.com) for advice if you are unsure of the most appropriate cabling. Also, check that your load is adequately shielded. It may be necessary to enclose the load in a metal enclosure.

If any of the connectors on the instrument are unused, they should be covered with shielded metal "dust caps" to reduce the interference potential.

This instrument does not normally require regular maintenance to minimize interference potential. However, if loose hardware or connectors are noted, they should be tightened. Contact Avtech (info@avtechpulse.com) if you require assistance.

EC DECLARATION OF CONFORMITY



We Avtech Electrosystems Ltd.
 P.O. Box 5120, LCD Merivale
 Ottawa, Ontario
 Canada K2C 3H5

declare that this pulse generator meets the intent of Directive 2004/108/EG for Electromagnetic Compatibility. Compliance pertains to the following specifications as listed in the official Journal of the European Communities:

EN 50081-1 Emission

EN 50082-1 Immunity

and that this pulse generator meets the intent of the Low Voltage Directive 2006/95/EC. Compliance pertains to the following specifications as listed in the official Journal of the European Communities:

EN 61010-1:2001 Safety requirements for electrical equipment for measurement, control, and laboratory use

DIRECTIVE 2011/65/EU (RoHS)

We Avtech Electrosystems Ltd.
P.O. Box 5120, LCD Merivale
Ottawa, Ontario
Canada K2C 3H5

declare that, to the best of our knowledge, all electrical and electronic equipment (EEE) sold by the company are in compliance with Directive 2011/65/EU of the European Parliament and of the Council of 8 June 2011 on the restriction of the use of certain hazardous substances in electrical and electronic equipment (also known as “RoHS Recast”). In addition, this declaration of conformity is issued under the sole responsibility of Avtech Electrosystems Ltd. Specifically, products manufactured do not contain the substances listed in the table below in concentrations greater than the listed maximum value.

<i>Material/Substance</i>	<i>Threshold level</i>
Lead (Pb)	< 1000 ppm (0.1% by mass)
Mercury (Hg)	< 1000 ppm (0.1% by mass)
Hexavalent Chromium (Cr6+)	< 1000 ppm (0.1% by mass)
Polybrominated Biphenyls (PBB)	< 1000 ppm (0.1% by mass)
Polybrominated Diphenyl ethers (PBDE)	< 1000 ppm (0.1% by mass)
Cadmium (Cd)	< 100 ppm (0.01% by mass)
Bis(2-ethylhexyl) phthalate (DEHP)	< 1000 ppm (0.1% by mass)
Butyl benzyl phthalate (BBP)	< 1000 ppm (0.1% by mass)
Dibutyl phthalate (DBP)	< 1000 ppm (0.1% by mass)
Diisobutyl phthalate (DIBP)	< 1000 ppm (0.1% by mass)

DIRECTIVE 2002/96/EC (WEEE)

European customers who have purchased this equipment directly from Avtech will have completed a “WEEE Responsibility Agreement” form, accepting responsibility for WEEE compliance (as mandated in Directive 2002/96/EC of the European Union and local

laws) on behalf of the customer, as provided for under Article 9 of Directive 2002/96/EC.

Customers who have purchased Avtech equipment through local representatives should consult with the representative to determine who has responsibility for WEEE compliance. Normally, such responsibilities will lie with the representative, unless other arrangements (under Article 9) have been made.

Requirements for WEEE compliance may include registration of products with local governments, reporting of recycling activities to local governments, and financing of recycling activities.

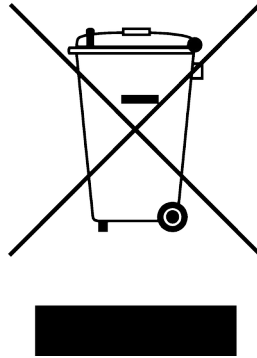

INSTALLATION

VISUAL CHECK

After unpacking the instrument mainframe and the transformer module, examine to ensure that they have not been damaged in shipment. Visually inspect all connectors, knobs, and handles. Confirm that a power cord and an instrumentation manual (this manual), are with the instrument. If the instrument has been damaged, file a claim immediately with the company that transported the instrument.

POWER RATINGS

This instrument is intended to operate from 100 - 240 V, 50 - 60 Hz.

The maximum power consumption is 57 Watts. Please see the "FUSES" section for information about the appropriate AC and DC fuses.

This instrument is an "Installation Category II" instrument, intended for operation from a normal single-phase supply.

CONNECTION TO THE POWER SUPPLY

An IEC-320 three-pronged recessed male socket is provided on the back panel for AC power connection to the instrument. One end of the detachable power cord that is supplied with the instrument plugs into this socket. The other end of the detachable power cord plugs into the local mains supply. Use only the cable supplied with the instrument. The mains supply must be earthed, and the cord used to connect the instrument to the mains supply must provide an earth connection. (The supplied cord does this.)

 Warning: Failure to use a grounded outlet may result in injury or death due to electric shock. This product uses a power cord with a ground connection. It must be connected to a properly grounded outlet. The instrument chassis is connected to the ground wire in the power cord.

The table below describes the power cord that is normally supplied with this instrument, depending on the destination region:

Destination Region	Description	Option	Manufacturer	Part Number
United Kingdom, Hong Kong, Singapore, Malaysia	BS 1363, 230V, 50 Hz	-AC00	Qualtek	370001-E01
Australia, New Zealand	AS 3112:2000, 230-240V, 50 Hz	-AC01	Qualtek	374003-A01
Continental Europe, Korea, Indonesia, Russia	European CEE 7/7 "Schuko" 230V, 50 Hz	-AC02	Qualtek	364002-D01
North America, Taiwan	NEMA 5-15, 120V, 60 Hz	-AC03	Qualtek	312007-01
Switzerland	SEV 1011, 230V, 50 Hz	-AC06	Qualtek	378001-E01
South Africa, India	SABS 164-1, 220-250V, 50 Hz	-AC17	Volex	2131H 10 C3
Japan	JIS 8303, 100V, 50-60 Hz	-AC18	Qualtek	397002-01
Israel	SI 32, 220V, 50 Hz	-AC19	Qualtek	398001-01
China	GB 1002-1 / 2099-1, 220V, 50 Hz	-AC22	Qualtek	399012-01

PROTECTION FROM ELECTRIC SHOCKS

 Operators of this instrument must be protected from electric shock at all times. The owner must ensure that operators are prevented access and/or are insulated from every connection point. In some cases, connections must be exposed to potential human contact. Operators must be trained to protect themselves from the risk of electric shock. This instrument is intended for use by qualified personnel who recognize shock hazards and are familiar with safety precautions required to avoid possibly injury. In particular, operators should:

1. Keep exposed high-voltage wiring to an absolute minimum.
2. Wherever possible, use shielded connectors and cabling.
3. Connect and disconnect loads and cables only when the instrument is turned off.
4. Keep in mind that all cables, connectors, oscilloscope probes, and loads must have an appropriate voltage rating.
5. Do not attempt any repairs on the instrument, beyond the fuse replacement procedures described in this manual. Contact Avtech technical support (see page 2 for contact information) if the instrument requires servicing. Service is to be performed solely by qualified service personnel.

ENVIRONMENTAL CONDITIONS

This instrument is intended for use under the following conditions:

1. indoor use;
2. altitude up to 2 000 m;
3. temperature 5 °C to 40 °C;
4. maximum relative humidity 80 % for temperatures up to 31 °C decreasing linearly to 50 % relative humidity at 40 °C;
5. Mains supply voltage fluctuations up to ± 10 % of the nominal voltage;
6. no pollution or only dry, non-conductive pollution.

FUSES

This instrument contains four fuses. All are accessible from the rear-panel. Two protect the AC prime power input, and two protect the internal DC power supplies. The locations of the fuses on the rear panel are shown in the figure below:

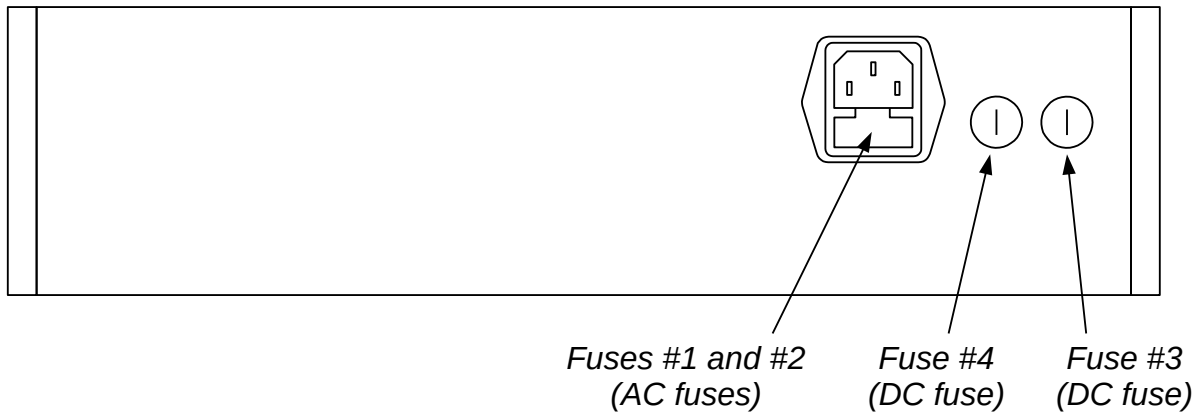

AC FUSE REPLACEMENT

To physically access the AC fuses, the power cord must be detached from the rear panel of the instrument. The fuse drawer may then be extracted using a small flat-head screwdriver, as shown below:

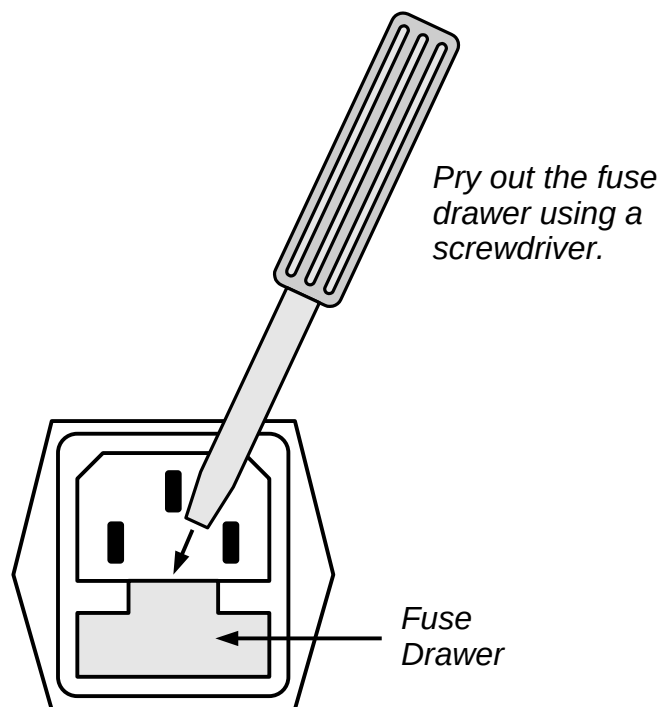

DC FUSE REPLACEMENT

The DC fuses may be replaced by inserting the tip of a flat-head screwdriver into the fuse holder slot, and rotating the slot counter-clockwise. The fuse and its carrier will then pop out.

FUSE RATINGS

The following table lists the required fuses:

Fuses	Nominal Mains Voltage	Rating	Case Size	Recommended Replacement Part	
				Littelfuse Part Number	Digi-Key Stock Number
#1, #2 (AC)	100-240V	0.5A, 250V, Time-Delay	5×20 mm	0218.500HXP	F2416-ND
#3 (DC)	N/A	1.0A, 250V, Time-Delay	5×20 mm	0218001.HXP	F2419-ND
#4 (DC)	N/A	Not used. A spare 1.0A fuse is installed here.			

The recommended fuse manufacturer is Littelfuse (<http://www.littelfuse.com>).

Replacement fuses may be easily obtained from Digi-Key (<http://www.digikey.com>) and other distributors.

FRONT PANEL CONTROLS

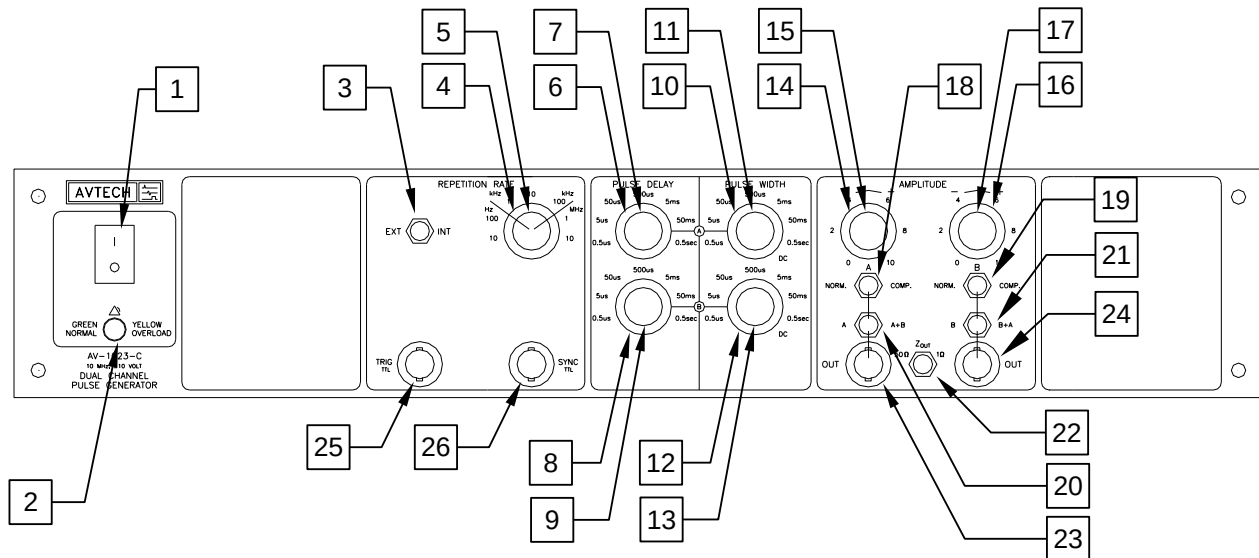

1. POWER Switch. This is the main power switch. When turning the instrument on, there may be a delay of several seconds before the instrument appears to respond.
2. OVERLOAD Indicator. When the instrument is powered, this indicator is normally green, indicating normal operation. If this indicator is yellow, an internal automatic overload protection circuit has been tripped. If the unit is overloaded (by operating at an exceedingly high duty cycle or by operating into a very low impedance), the protective circuit will disable the output of the instrument and turn the indicator light yellow. The light will stay yellow (i.e. output disabled) for about 5 seconds after which the instrument will attempt to re-enable the output (i.e. light green) for about 1 second. If the overload condition persists, the output will be disabled again (i.e. light yellow) for another 5 seconds. If the overload condition has been removed, the instrument will resume normal operation.

This overload indicator may flash yellow briefly at start-up. This is not a cause for concern.
3. INT/EXT switch. In the "INT" position the instrument is internally triggered (i.e. the pulse repetition frequency is controlled by the REPETITION RATE front panel controls). In the "EXT" position the instrument is triggered by a TTL pulse (0 to +5V) on the "TRIG" connector.
4. REPETITION RATE outer knob. This selects one of the seven pulse repetition rate ranges:

1 Hz - 10 Hz
 10 Hz - 100 Hz
 100 Hz - 1 kHz
 1 kHz - 10 kHz

10 kHz - 100 kHz
 100 kHz - 1 MHz
 1 MHz - 10 MHz

5. REPETITION RATE inner knob. This varies the pulse repetition rate within the selected range.
6. PULSE DELAY A outer knob. This selects one of the seven delay ranges for channel "A":
 - 0.05 ms - 0.5 ms
 - 0.5 ms - 5 ms
 - 5 ms - 50 ms
 - 50 ms - 500 ms
 - 500 ms - 5 ms
 - 5 ms - 50 ms
 - 50 ms - 0.5 sec
7. PULSE DELAY A inner knob. This varies the channel "A" delay within the selected range.
8. PULSE DELAY B outer knob. This selects one of the seven delay ranges for channel "B".
9. PULSE DELAY B inner knob. This varies the channel "B" delay within the selected range.
10. PULSE WIDTH A outer knob. This selects one of the seven pulse width ranges for channel "A":
 - 0.05 ms - 0.5 ms
 - 0.5 ms - 5 ms
 - 5 ms - 50 ms
 - 50 ms - 500 ms
 - 500 ms - 5 ms
 - 5 ms - 50 ms
 - 50 ms - 0.5 sec
 - DC (i.e. constant output)
11. PULSE WIDTH A inner knob. This varies the channel "A" pulse width within the selected range.
12. PULSE WIDTH B outer knob. This selects one of the seven pulse width ranges for channel "B".
13. PULSE WIDTH B inner knob. This varies the channel "B" pulse width within the selected range.
14. AMPLITUDE A outer knob. This switch selects the output polarity (positive or negative) of channel "A".

15. AMPLITUDE A inner knob. This varies the output amplitude of channel "A" between 0 and 10 Volts.
16. AMPLITUDE B outer knob. This switch selects the output polarity (positive or negative) of channel "B".
17. AMPLITUDE B inner knob. This varies the output amplitude of channel "B" between 0 and 10 Volts.
18. NORM/COMP A switch. In the "NORM" position, channel "A" is logically non-inverted. In the "COMP" position, channel "A" is logically complemented (i.e. inverted). In the complemented state, the high and low voltage levels are reversed relative to the "NORM" state. The polarities do not change.
19. NORM/COMP B switch. In the "NORM" position, channel "B" is logically non-inverted. In the "COMP" position, channel "B" is logically complemented (i.e. inverted). In the complemented state, the high and low voltage levels are reversed relative to the "NORM" state. The polarities do not change.
20. A/A+B switch. In the "A" position, the leftmost OUT connector (item 23) outputs channel "A". In the "A+B" position, this connector provides the sum of channels "A" and "B" instead.
21. B/B+A switch. In the "B" position, the rightmost OUT connector (item 24) outputs channel "B". In the "B+A" position, this connector provides the sum of channels "B" and "A" instead.
22. ZOUT switch. This switch sets the output impedance of the two main outputs (items 23 and 24). The output impedance can be 1W or 50W.
23. OUT, left connector. This connector provides either "A" or "A+B" outputs, depending on this position of the A/A+B switch. The output impedance is set by the ZOUT switch.
24. OUT, right connector. This connector provides either "B" or "B+A" outputs, depending on this position of the B/B+A switch. The output impedance is set by the ZOUT switch.
25. SYNC connector. This output supplies a TTL-level pulse to trigger oscilloscopes or other measurement equipment. The output pulse width is nominally fixed at 50ns.
26. TRIG connector. If the INT/EXT switch (item 3) is in the "EXT" position, the external TTL-level trigger should be applied to this input. When the INT/EXT switch is in the "INT" position, this input has no effect. However, it should be left unconnected to avoid electromagnetic interference with the internal clock.

REAR PANEL CONTROLS

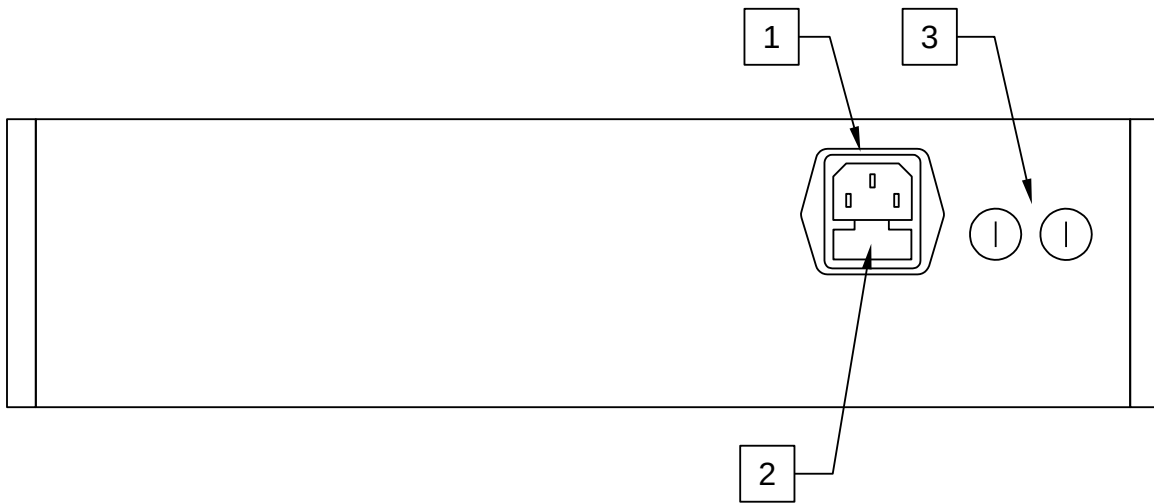

1. AC POWER INPUT. An IEC-320 C14 three-pronged recessed male socket is provided on the back panel for AC power connection to the instrument. One end of the detachable power cord that is supplied with the instrument plugs into this socket.
2. AC FUSE DRAWER. The two fuses that protect the AC input are located in this drawer. Please see the “FUSES” section of this manual for more information.
3. DC FUSES. These two fuses protect the internal DC power supplies. Please see the “FUSES” sections of this manual for more information.

GENERAL INFORMATION

BASIC PULSE CONTROL

This instrument can be triggered by its own internal clock or by an external TTL trigger signal. In either case, three output channels respond to the trigger: A, B, and SYNC.

- A. This is the main signal for left OUT connector. The pulse width, amplitude, and offset are all adjustable. The maximum output voltage is $\pm 10\text{V}$. (This voltage is reduced by a factor of two if the output impedance is set at 50Ω , and a 50Ω load is used.)
- B. This is the main signal for right OUT connector. The pulse width, amplitude, and offset are all adjustable. The maximum output voltage is $\pm 10\text{V}$. (This voltage is reduced by a factor of two if the output impedance is set at 50Ω , and a 50Ω load is used.)
- SYNC. The SYNC pulse is a fixed-width TTL-level reference pulse used to trigger oscilloscopes or other measurement systems. It precedes all other outputs.

These pulses are illustrated below, assuming internal triggering and a non-zero delay setting:

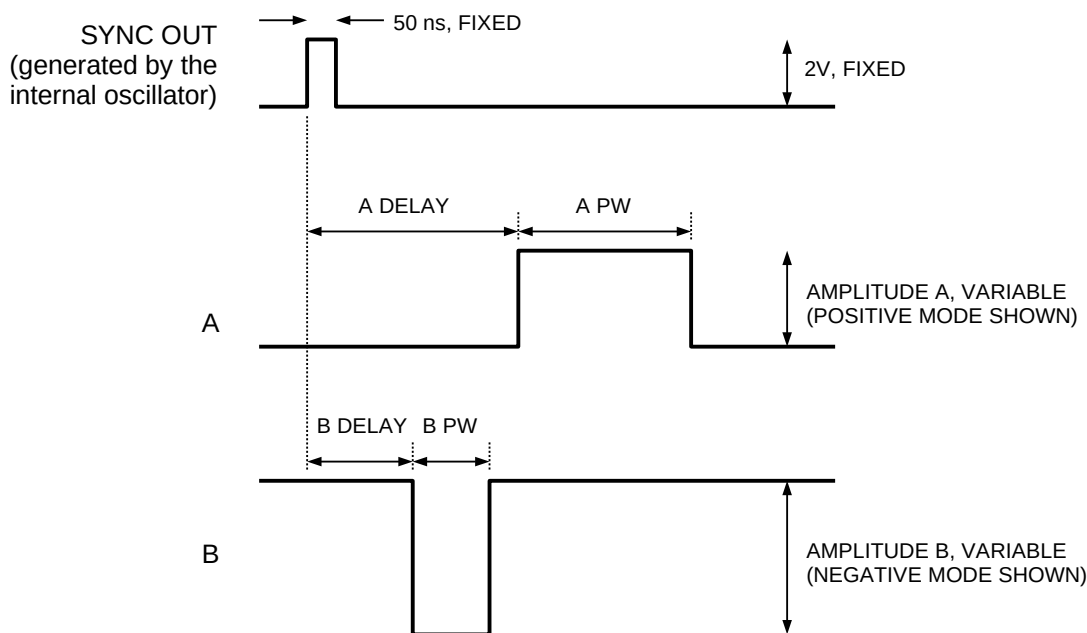

The next figure illustrates the relationship between the signals when an external TTL-level trigger is used (i.e., the INT/EXT switch is set to “EXT”):

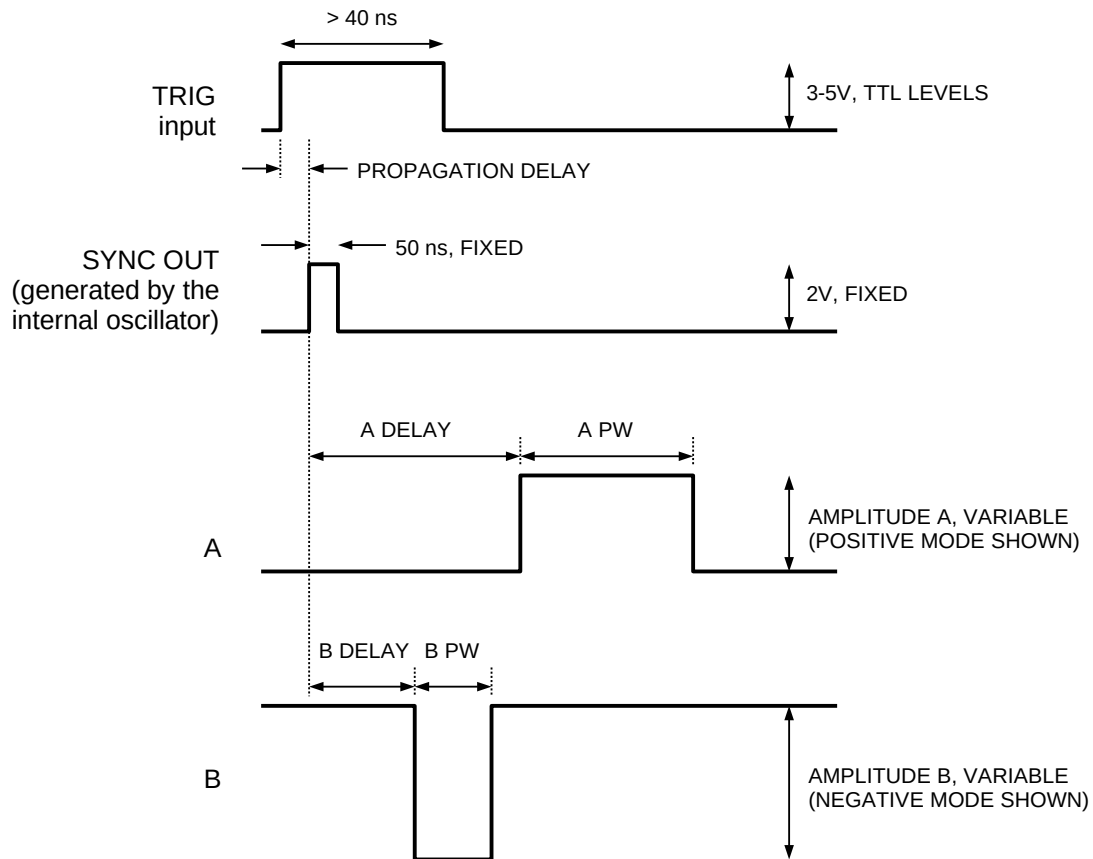

SUMMING OUTPUTS

The two output connectors can supply A and B directly, or they can be added together, and the two output connectors can be used to supply two of A, B, or $A+B=B+A$. This allows complex waveforms to be constructed. Some examples are shown below.

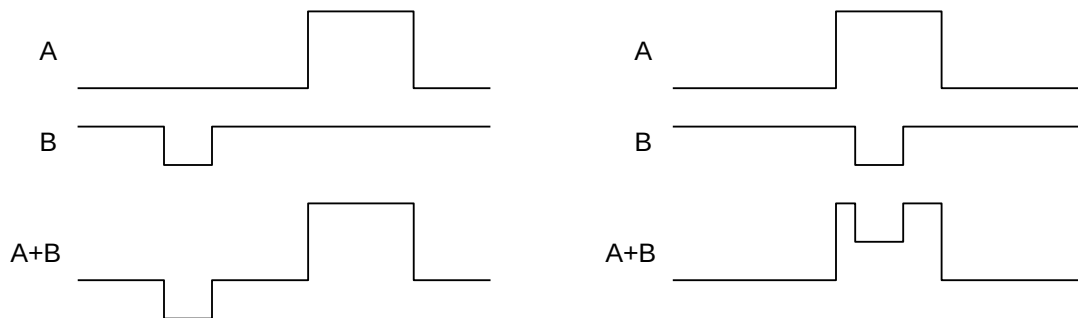

NORM/COMP MODES

The pulses of channels A and B may be of either polarity (i.e. positive or negative). In addition, the NORM/COMP switches allow pulses to be inverted logically - the high and low voltages can be swapped. This is illustrated below.

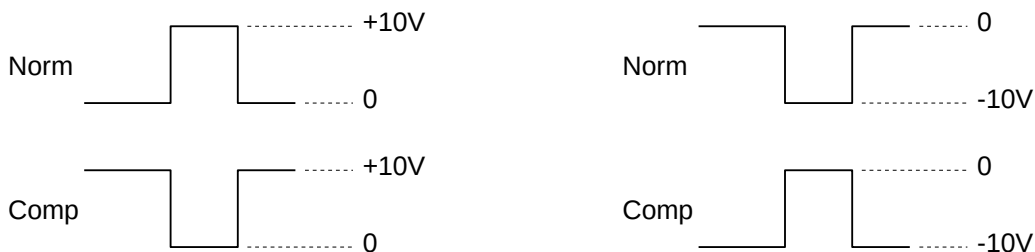

OUTPUT IMPEDANCE

The output impedance can be set to be 1Ω or 50Ω . The 50Ω position is useful for driving 50Ω transmission lines since this output impedance will provide back-matching, which suppresses transmission line reflections. Note however that when driving a 50Ω load with the switch in the 50Ω position will reduce the output voltage by a factor of 2, due to a voltage divider effect. The 1Ω position eliminates this voltage reduction.

MINIMIZING WAVEFORM DISTORTIONS

USE 50Ω TRANSMISSION LINES

Connect the load to the pulse generator with 50Ω transmission lines (e.g. RG-58 or RG-174 cable). If possible, use a 50Ω load. If the actual device under test has a high impedance, consider adding a 50Ω termination in parallel with the load to properly terminate the transmission line.

USE LOW-INDUCTANCE LOADS

Lenz's Law predicts that for an inductive voltage spike will be generated when the current through an inductance changes. Specifically, $V_{\text{SPIKE}} = L \times di_{\text{LOAD}}/dt$, where L is the inductance, i_{LOAD} is the load current change, and t is time. For this reason, it is important to keep any parasitic in the load low. This means keeping wiring short, and using low inductance components. In particular, wire-wound resistors should be avoided.

MECHANICAL INFORMATION

TOP COVER REMOVAL

If necessary, the interior of the instrument may be accessed by removing the four Phillips screws on the top panel. With the four screws removed, the top cover may be slid back (and off).

 Always disconnect the power cord and allow the instrument to sit unpowered for 10 minutes before opening the instrument. This will allow any internal stored charge to discharge.

There are no user-adjustable internal circuits. For repairs other than fuse replacement, please contact Avtech (info@avtechpulse.com) to arrange for the instrument to be returned to the factory for repair. Service is to be performed solely by qualified service personnel.

 Caution: High voltages are present inside the instrument during normal operation. Do not operate the instrument with the cover removed.

ELECTROMAGNETIC INTERFERENCE

To prevent electromagnetic interference with other equipment, all used outputs should be connected to shielded loads using shielded coaxial cables. Unused outputs should be terminated with shielded coaxial terminators or with shielded coaxial dust caps, to prevent unintentional electromagnetic radiation. All cords and cables should be less than 3m in length.

MAINTENANCE

REGULAR MAINTENANCE

This instrument does not require any regular maintenance.

On occasion, one or more of the four rear-panel fuses may require replacement. All fuses can be accessed from the rear panel. See the “FUSES” section for details.

CLEANING

If desired, the interior of the instrument may be cleaned using compressed air to dislodge any accumulated dust. (See the “TOP COVER REMOVAL” section for instructions on accessing the interior.) No other cleaning is recommended.

WIRING DIAGRAMS

WIRING OF AC POWER

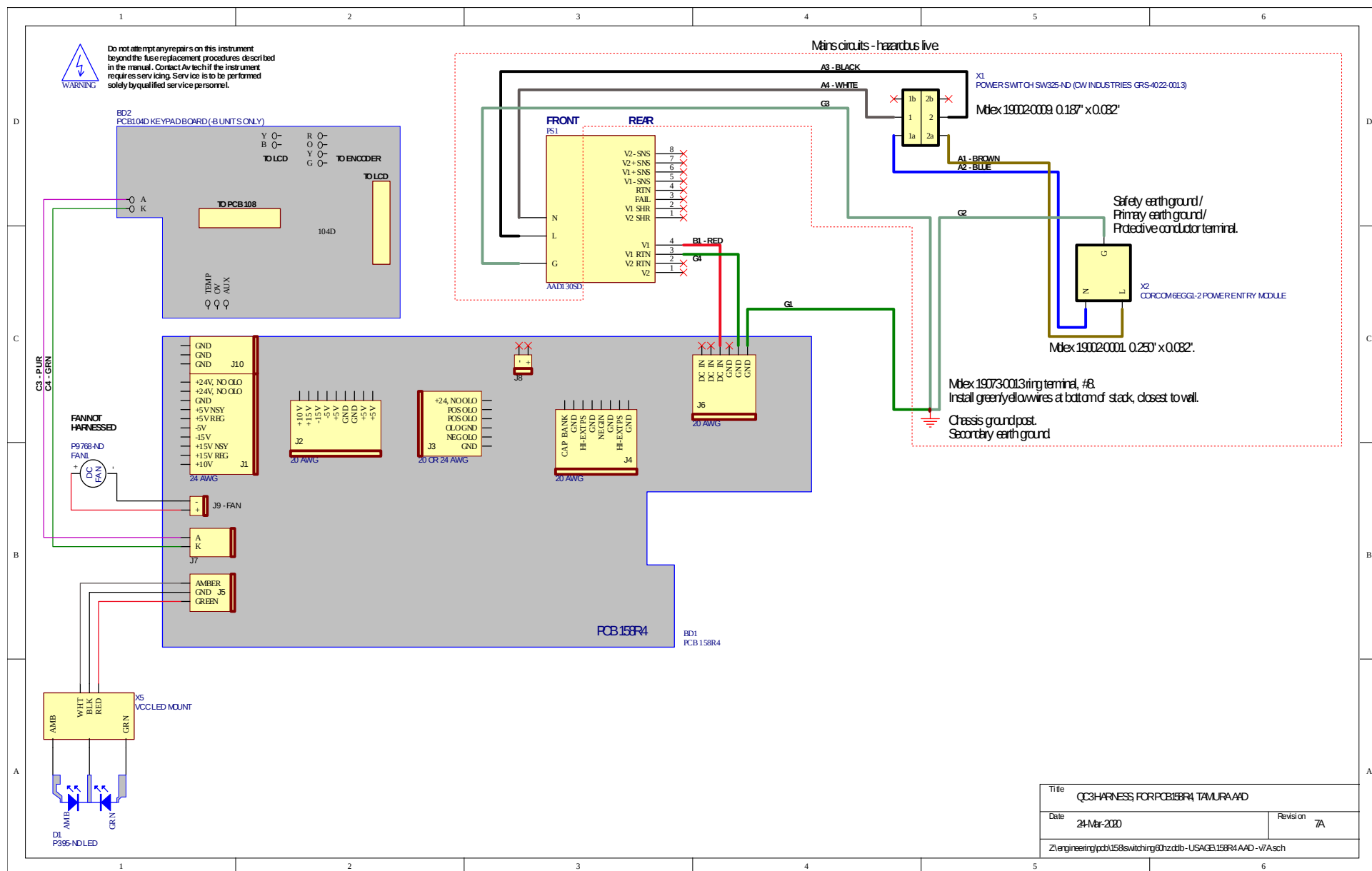

Title		QC3 HARNESS FOR PCB158R4 TAMURA AD	
Date	24-Mar-2020	Revision	7A
Z:\engineering\pcb\158switching\0hz\dlb-USAGE\158R4 AAD-V7A.sch			

PCB 134B - MAIN BOARD

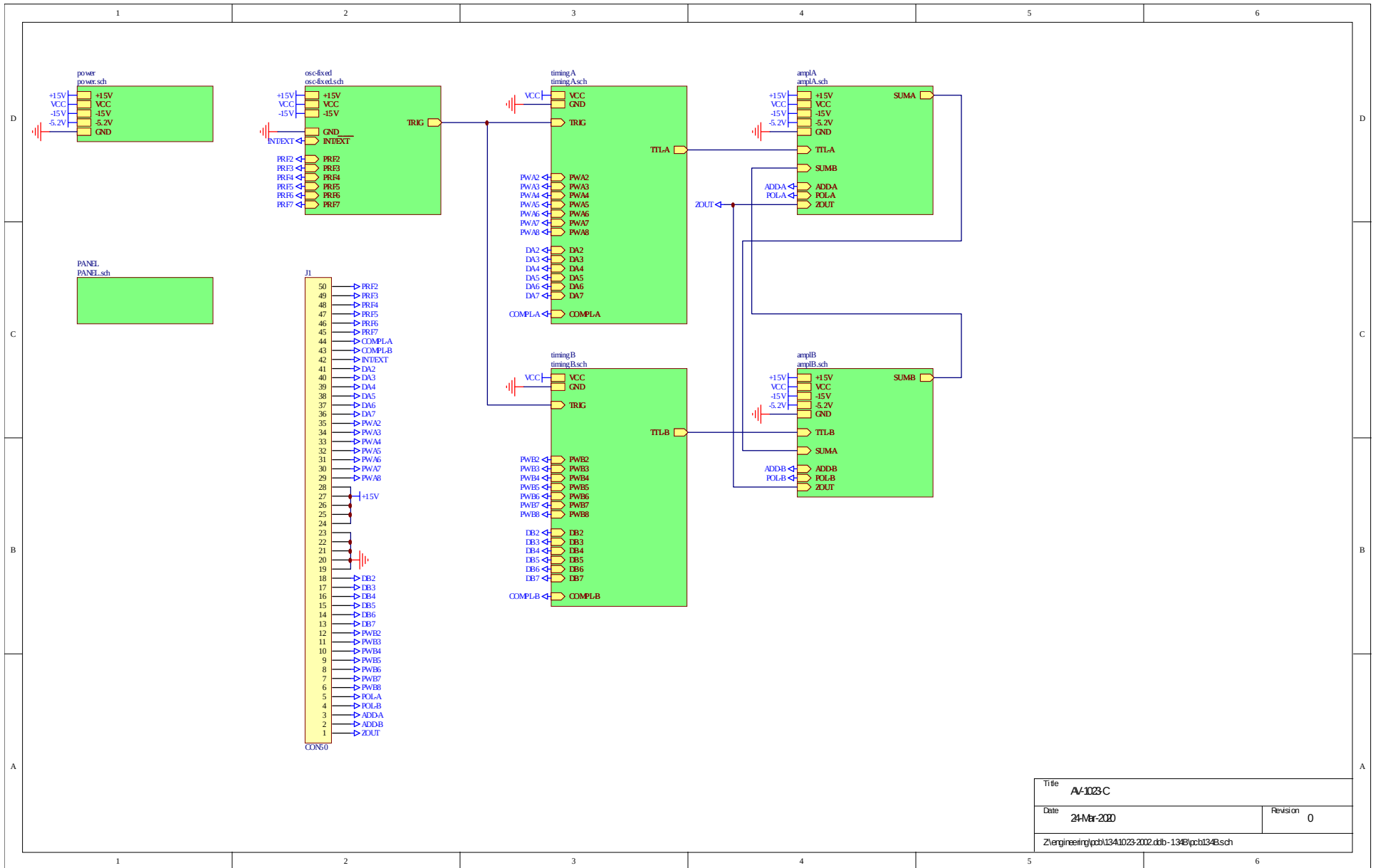

Title	A-1023 C	
Date	24-Mar-2020	Revision 0
Z:\engineering\pcb\134\1023-2020.dtb-134B\pcb134B.sch		

PCB 134B - MAIN BOARD - DC POWER

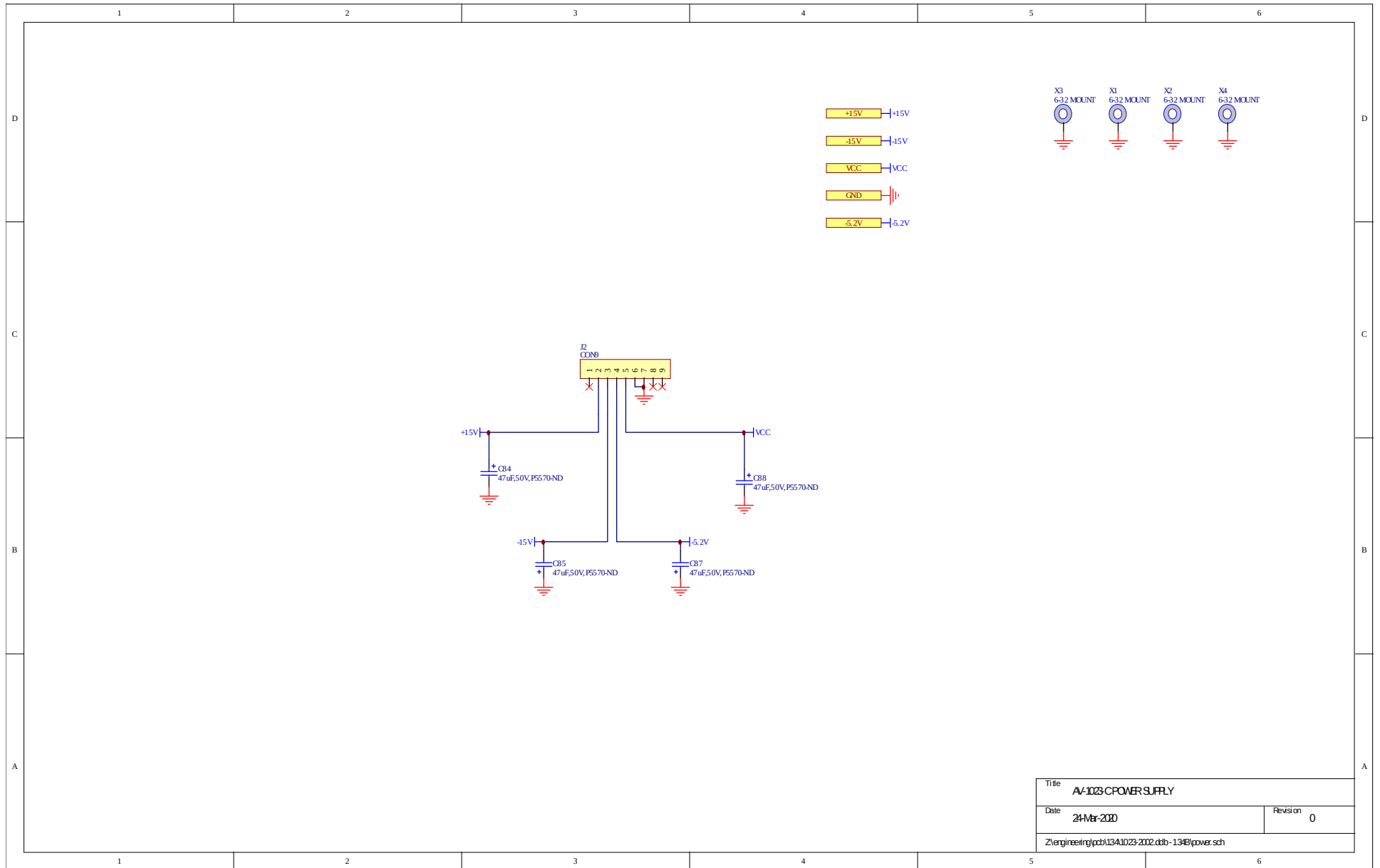

PCB 134B - MAIN BOARD - OSCILLATOR

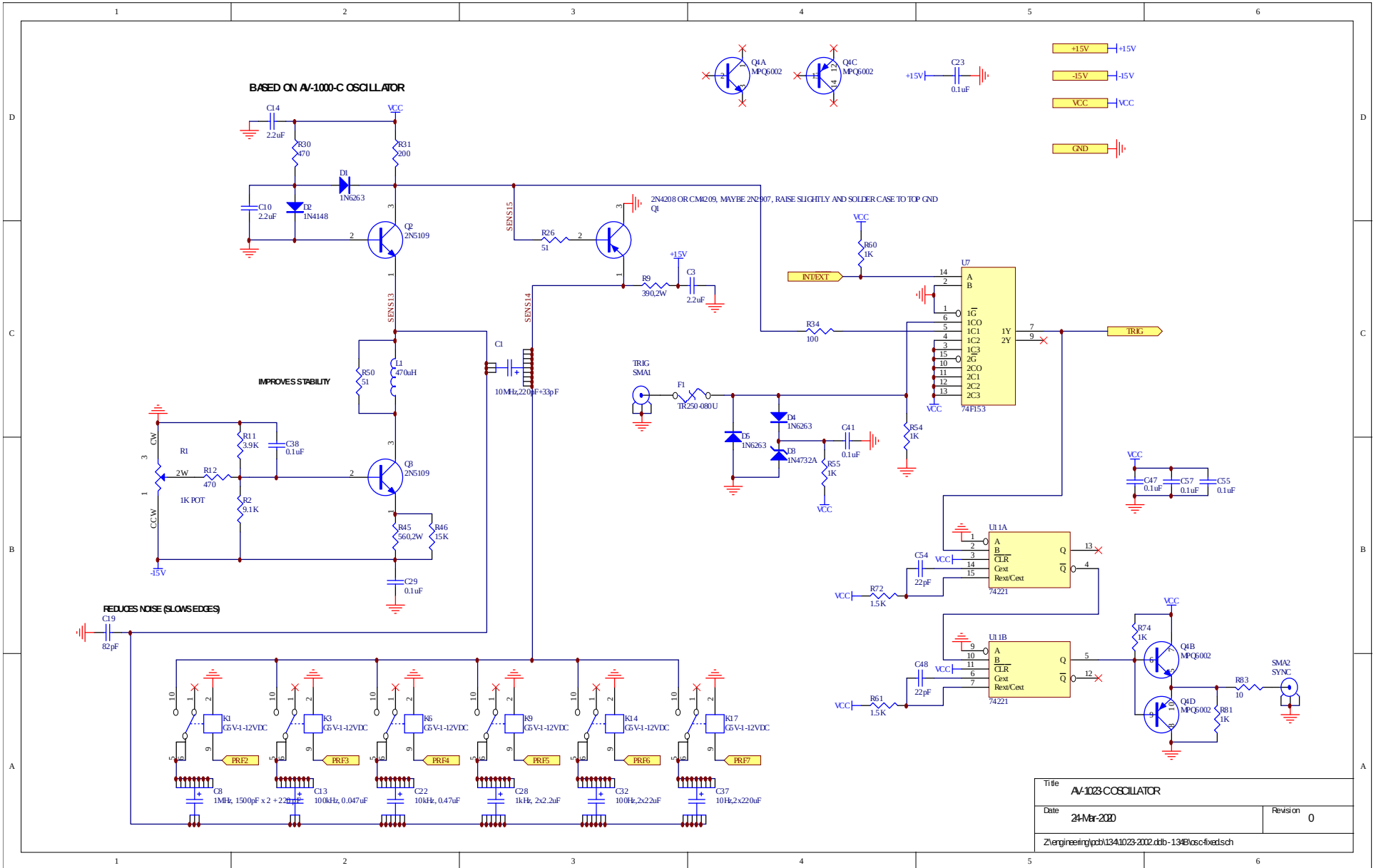

Title: A-1000-C OSCILLATOR	
Date: 24-Mar-2002	Revision: 0
Z:\engineering\pcb\134\1023-2002\dib-134B\osc\fixed.sch	

PCB 134B - MAIN BOARD - TIMING A

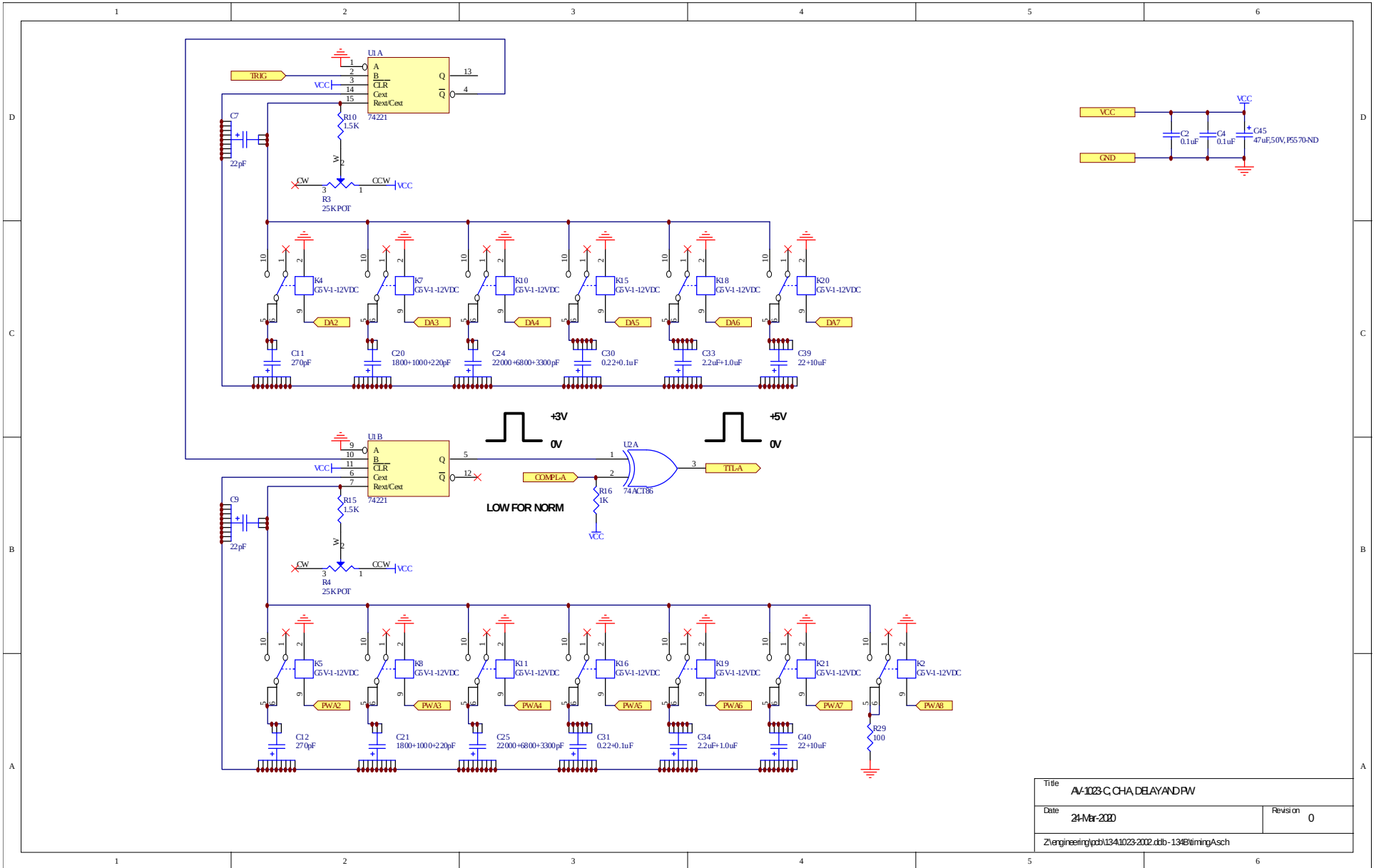

Title		AV-1023-C,CHA,DELAY,ANDRW
Date	24-Mar-2020	Revision 0
Z:\engineering\pcb\134\1023-2020.dtb-134B\timingA.sch		

PCB 134B - MAIN BOARD - TIMING B

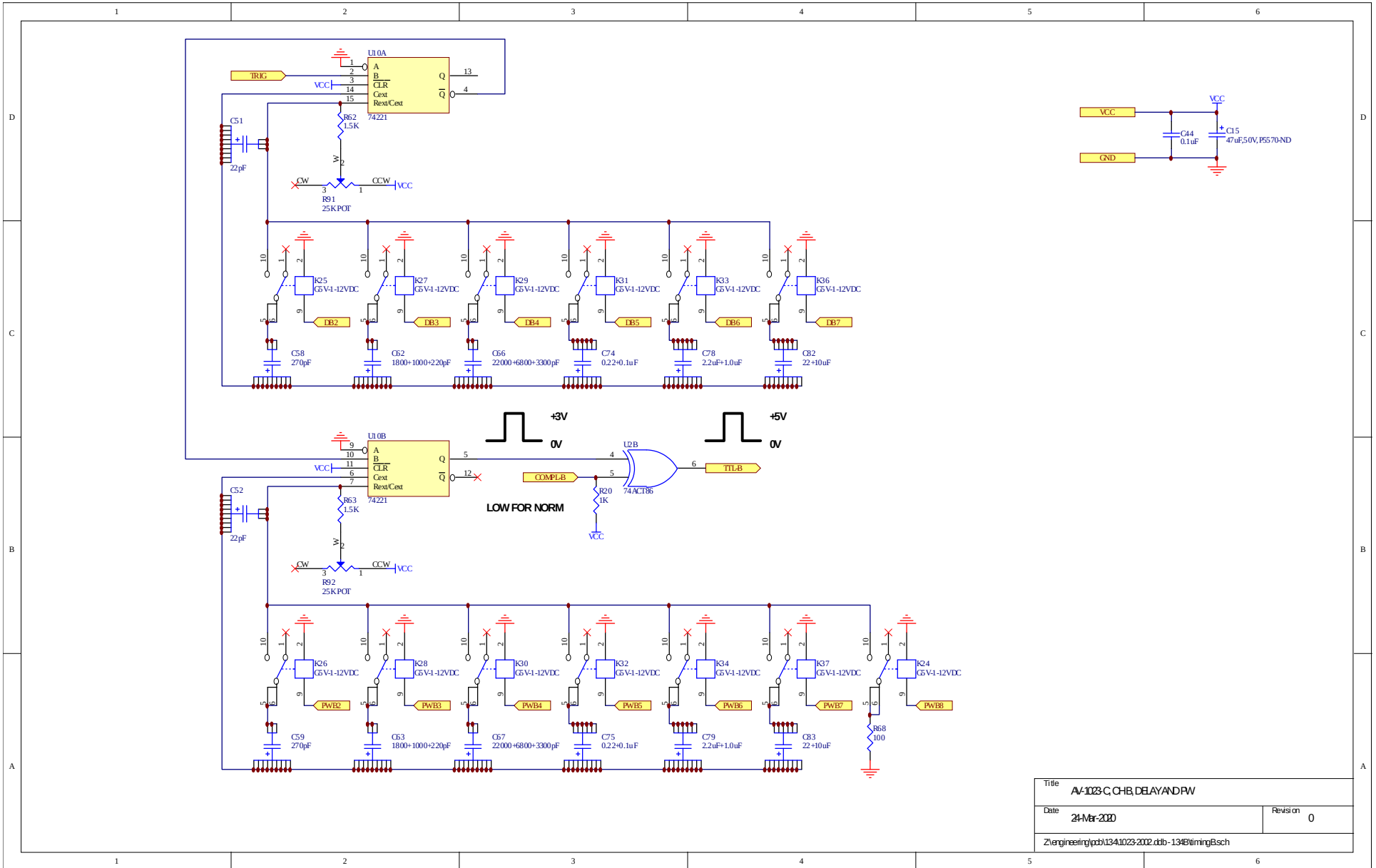

PCB 134B - MAIN BOARD - AMPLITUDE A

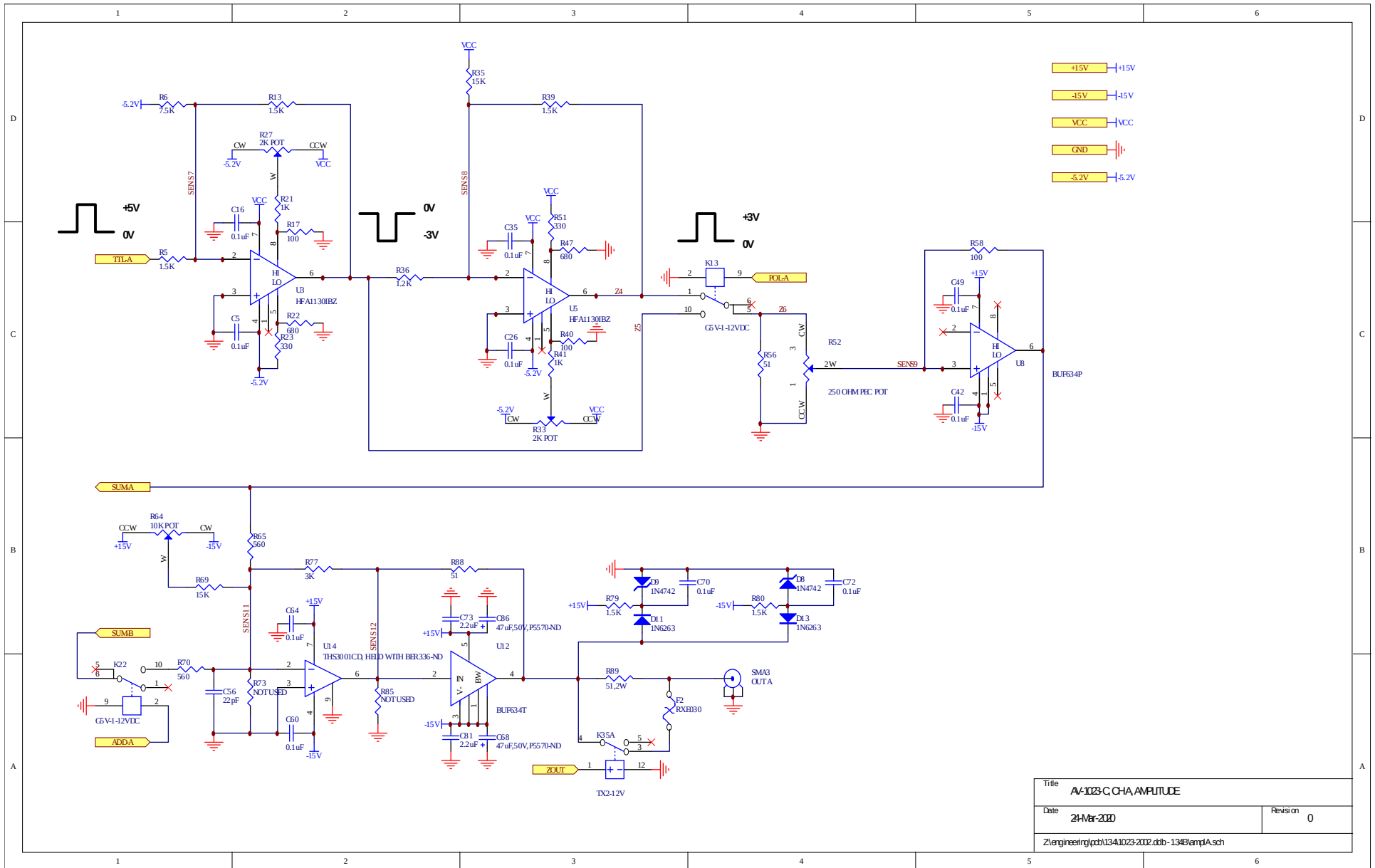

PCB 134B - MAIN BOARD - AMPLITUDE B

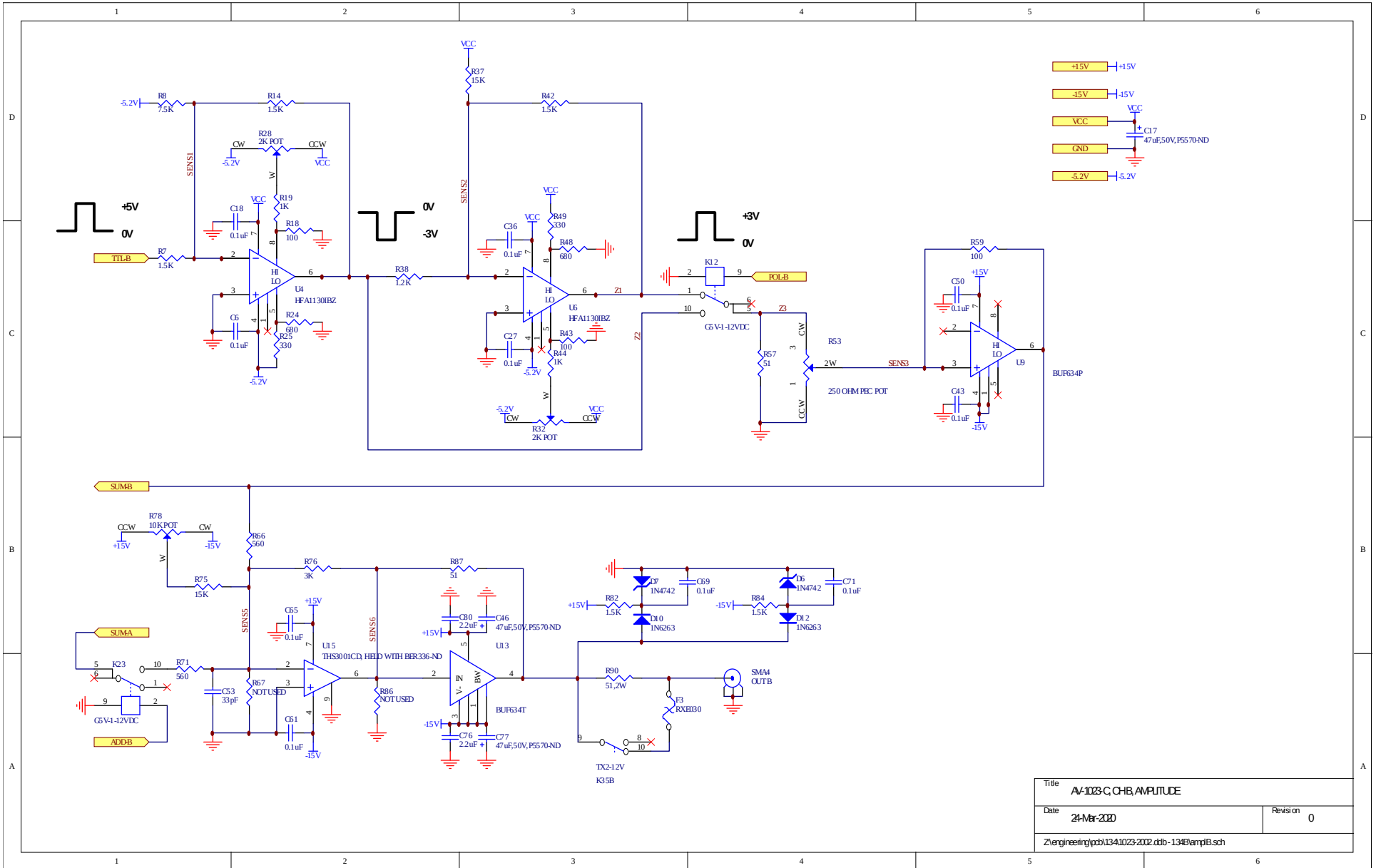

Title: A-1023-C, CHB, AMPLITUDE	
Date: 24-Mar-2022	Revision: 0
Z:\engineering\pcb\134\1023-2022.dtb-134B\amp1B.sch	

PCB 134B - MAIN BOARD - FRONT PANEL

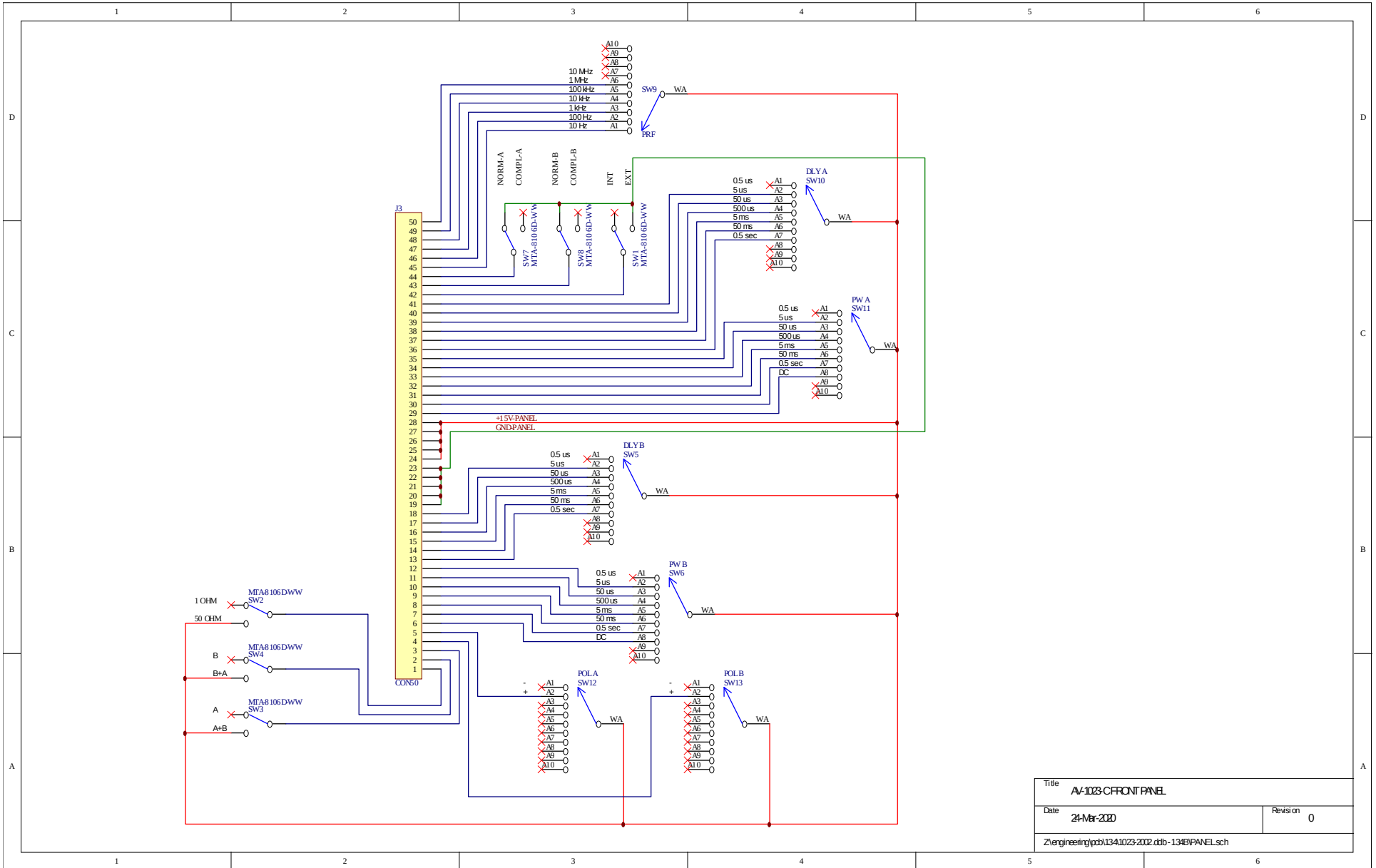

Title		A-1023-CFRONT PANEL
Date	24-Mar-2020	Revision 0
Z:\engineering\pcb\134\1023-2020.dtb-134BPANEL.sch		

PERFORMANCE CHECK SHEET