

INSTRUCTIONS

MODEL AV-1030-C

0 TO 5 VOLTS, 10 MHz

GENERAL PURPOSE PULSE GENERATOR

WITH 200 ps RISE TIME, 300 ps FALL TIME

SERIAL NUMBER: _____

WARRANTY

Avtech Electrosystems Ltd. warrants products of its manufacture to be free from defects in material and workmanship under conditions of normal use. If, within one year after delivery to the original owner, and after prepaid return by the original owner, this Avtech product is found to be defective, Avtech shall at its option repair or replace said defective item. This warranty does not apply to units which have been disassembled, modified or subjected to conditions exceeding the applicable specifications or ratings. This warranty is the extent of the obligation assumed by Avtech with respect to this product and no other warranty or guarantee is either expressed or implied.

TECHNICAL SUPPORT

Phone: 613-226-5772 or 1-800-265-6681

Fax: 613-226-2802 or 1-800-561-1970

E-mail: info@avtechpulse.com

World Wide Web: <http://www.avtechpulse.com>

TABLE OF CONTENTS

WARRANTY	2
TECHNICAL SUPPORT	2
TABLE OF CONTENTS	3
INTRODUCTION	4
SPECIFICATIONS	5
INSTALLATION	6
VISUAL CHECK	6
PLUGGING IN THE INSTRUMENT	6
FRONT PANEL CONTROLS	7
REAR PANEL CONTROLS	10
GENERAL INFORMATION	11
BASIC PULSE CONTROL	11
TRIGGER MODES	13
GATING MODES	13
MINIMIZING WAVEFORM DISTORTIONS	15
USE 50Ω TRANSMISSION LINES AND LOADS	15
USE LOW-INDUCTANCE LOADS	15
MECHANICAL INFORMATION	16
TOP COVER REMOVAL	16
RACK MOUNTING	16
ELECTROMAGNETIC INTERFERENCE	16
OPERATIONAL CHECK	17
TYPICAL WAVEFORMS	20
REPAIR INSTRUCTIONS	21
BLOWN AC FUSE	21
DAMAGED MAIN OUTPUT	21
PERFORMANCE CHECK SHEET	22

INTRODUCTION

The Avtech AV-1030-C is a versatile, general-purpose, low-cost, 10 MHz laboratory pulse generator, useful everywhere from undergraduate university classrooms to the most advanced research and development laboratories. This pulse generator features variable pulse repetition frequency (PRF), delay, pulse width, and amplitude. It also features an exceptionally fast 200 ps rise time, and 300 ps fall time.

The generator can be triggered internally or externally, or by the manual "Single Pulse" pushbutton. All trigger sources can be gated by a TTL-type pulse. The internal trigger is continuously variable from 1 Hz to 10 MHz. The delay is variable up to 1 second, and the pulse width is variable to 1 ms. The amplitude is variable from 0 to 5V.

The main output has all of its characteristics variable, and is designed to drive 50 loads. (A 50 load is required for proper operation.) The main output is AC-coupled. Two logic outputs (TTL and ECL) have approximately the same timing characteristics as the main output, but have their amplitudes fixed at standard logic levels.

A synchronizing trigger output is also supplied, for triggering oscilloscopes and other test equipment (50 ns wide, +2V into 50).

Several points should be noted when operating this instrument:

This unit *requires* a 50 ohm load.

The maximum main output duty cycle is 10%.

The main output is AC-coupled.

SPECIFICATIONS

Model:	AV-1030-C
Amplitude (to 50 Ohms):	0 to 5 Volts
Output impedance:	50 Ohms
Rise time:	200 ps
Fall time:	300 ps
PRF:	1 Hz to 10 MHz
Pulse width:	10 ns to 1 ms
Required load impedance:	50 Ohms
Jitter (Sync out to pulse out):	25 ps 0.01 % of sync delay
Polarity (main output):	Positive or negative (switch-selectable)
Duty cycle (max):	10 %
Waveform aberrations:	Overshoot, undershoot, ringing and slope aberration are less than 5% at amplitudes of 300 mV and higher with outputs terminating in 50 .
Propagation delay (Ext trig in to pulse out):	60 ns to 1 s
Trigger required (Ext trig mode):	+ 5 Volts, 4 ns TTL
Trigger required (Gate in):	0 to 0.8 V (or grounded): No output + 2.8 V to + 5.0 V (or open): Normal output
Sync delay (Sync out to pulse out):	45 ns to 1 s
Sync output:	+2 Volts, 50 ns, will drive 50 Ohm loads
Single pulse mode:	Manual Push Button
Signal connectors:	Main output: SMA Other: BNC
Power requirement:	120/240 Volts (switchable), 50 - 60 Hz
Dimensions (H x W x D):	100 mm x 430 mm x 375 mm (3.9" x 17" x 14.8")
Weight & chassis material:	4.5 kg (10 lb.), anodized aluminum, with blue plastic trim
Mounting & Temperature range:	Any, +10 C to +40 C

INSTALLATION

VISUAL CHECK

After unpacking the instrument, examine to ensure that it has not been damaged in shipment. Visually inspect all connectors, knobs, and handles. Confirm that a power cord is with the instrument. If the instrument has been damaged, file a claim immediately with the company that transported the instrument.

PLUGGING IN THE INSTRUMENT

Examine the rear of the instrument. There will be a male power receptacle, a fuse holder and the edge of the power selector card visible. Confirm that the power selector card is in the correct orientation.

For AC line voltages of 110-120V, the power selector card should be installed so that the "120" marking is visible from the rear of the instrument.

For AC line voltages of 220-240V, the power selector card should be installed so that the "240" marking is visible from the rear of the instrument.

If it is not set for the proper voltage, remove the fuse and then grasp the card with a pair of pliers and remove it. Rotate horizontally through 180 degrees. Reinstall the card and the correct fuse.

In the 120V setting, a 1.0A slow blow fuse is required. In the 240V setting, a 0.5A slow blow fuse is required.

FRONT PANEL CONTROLS

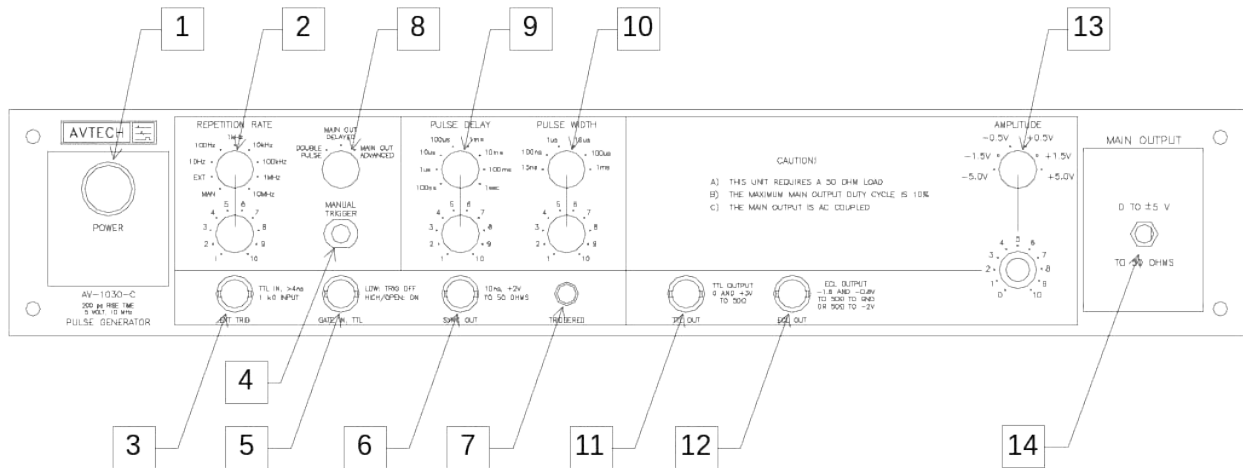

1. **POWER Switch.** The POWER push button switch applies AC prime power to the primaries of the transformer, turning the instrument on. The push button lamp (#382 type) is connected to the internal +15V DC supply.
2. **REPETITION RATE Controls.** This switch sets the triggering mode for the instrument.

In the “MAN” position, the instrument is triggered by the “Manual Trigger” pushbutton (item 4).

In the “EXT” rate position, the instrument is triggered by externally-generated TTL-level (0 and 3-5V logic levels) pulses on the “EXT TRIG” input connector (item 3).

The remaining positions serve as decade-range controls for the internal oscillator, which triggers the instrument in these positions. The vernier control immediately below the switch provides continuous adjustment of the frequency within each decade range.

3. **EXT TRIG Connector.** When the REPETITION RATE switch (item 2) is set to the “EXT” position, a TTL-level pulse applied to this input will trigger the instrument.
4. **MANUAL TRIGGER Pushbutton.** When the REPETITION RATE switch (item 2) is set to the “MAN” position, the instrument is triggered by pressing this pushbutton. A single trigger event occurs for each press of the pushbutton.
5. **GATE IN Connector.** This TTL-level (i.e., 0 and 3-5V logic levels) input gates the trigger. If this input is unconnected or TTL-high (3 to 5V), the instrument will trigger

normally. If this input is TTL-low (0 Volts), triggering is inhibited.

6. SYNC OUT Connector. This output generates a 50 ns wide TTL-level pulse for each trigger event. This output can be used to trigger an oscilloscope, or other test equipment.

The PULSE DELAY controls (item 9) and DELAY MODE switch (item 8) affect the operation of this output. When the DELAY MODE switch is in the “Main Out Delayed” position, the pulses on the main output (item 14) and the logic outputs (items 11 and 12) are delayed relative to the SYNC OUT pulse by a time controlled by the PULSE DELAY controls (item 9).

When the DELAY MODE switch is in the “Main Out Advanced” position, the pulses on the main output (item 14) and the logic outputs (items 11 and 12) are advanced relative to the SYNC OUT pulse by a time controlled by the PULSE DELAY controls (item 9).

When the DELAY MODE switch is in the “Double Pulse” position, the SYNC OUT pulse is approximately coincident with the first pulse of the pair of pulses on the main output.

For this output to operate correctly, the delay setting must be less than the period.

7. TRIGGERED Indicator. This indicator is lit when pulses are detected on the logic outputs (items 11 and 12), and it gives an indication that the timing parameters have been set properly and do not conflict.

If this indicator is not lit, it suggests that instrument is not triggering, or that the delay or pulse width settings exceed the pulse period.

8. DELAY MODE Switch. This switch determines the function of the PULSE DELAY controls (item 9). When this switch is set in the “DOUBLE PULSE” position, the main output (item 14) and the logic outputs (items 11 and 12) generate a pair of pulses in response to each trigger event. The DELAY controls determine the spacing between the first and second pulses in the pair. The SYNC OUT pulse is approximately coincident with the first pulse of the pair of pulses on the main output.

When the DELAY MODE switch is in the “Main Out Delayed” position, the pulses on the main output (item 14) and the logic outputs (items 11 and 12) are delayed relative to the SYNC OUT pulse by a time controlled by the PULSE DELAY controls (item 9). The SYNC OUT pulse itself is generated after a minimal delay relative to the trigger source. (This is the most common mode of operation.)

When the DELAY MODE switch is in the “Main Out Advanced” position, the pulses on the main output (item 14) and the logic outputs (items 11 and 12) are approximately coincident with the trigger event, and the SYNC output is delayed

relative to the main output and logic outputs by a time controlled by the PULSE DELAY controls (item 9).

9. PULSE DELAY Controls. This decade range switch, and the vernier control immediately below, control the separation between the main and logic outputs (items 11, 12 and 14) and the SYNC OUT output (item 6).
10. PULSE WIDTH Controls. This decade range switch, and the vernier control immediately below, control the pulse width of the main and logic outputs (items 11, 12 and 14).
11. TTL OUT Connector. This output provides a TTL-level pulse (quiescent level: 0V, pulse level: 3-5V) whose triggering, delay, and pulse width are controlled by the front-panel controls. The amplitude and rise and fall times are fixed. This output will drive impedances of 50 Ohms or greater. To minimize distortion, this output should ideally be connected using 50 Ohm coaxial cabling, and terminated with a 50 Ohm load.
12. ECL OUT Connector. This output provides an ECL-level pulse (quiescent level: -1.6V, pulse level: -0.8V) whose triggering, delay, and pulse width are controlled by the front-panel controls. The amplitude and rise and fall times are fixed. This output will drive a load of 50 Ohms or greater, connected to ground or to -2V. To minimize distortion, this output should ideally be connected using 50 Ohm coaxial cabling, and terminated with a 50 Ohm load.
13. AMPLITUDE Controls. This range switch and vernier dial control the amplitude of the main output (item 14).

The best performance will be obtained when the lowest amplitude range consistent with the desired amplitude is used.

14. MAIN OUTPUT Connector. This is the main output. The amplitude may be varied between -5V and +5V. A 50 Ω load is *required* for proper operation. (This output will not operate properly into a high impedance load.) This output is AC-coupled.

REAR PANEL CONTROLS



15. AC POWER INPUT. A three-pronged recessed male connector is provided on the back panel for AC power connection to the instrument. Also contained in this assembly is a slow blow fuse and a removable card that can be removed and repositioned to switch between 120V AC in and 240V AC in.

For AC line voltages of 110-120V, the power selector card should be installed so that the “120” marking is visible from the rear of the instrument.

For AC line voltages of 220-240V, the power selector card should be installed so that the “240” marking is visible from the rear of the instrument.

If it is not set for the proper voltage, remove the fuse and then grasp the card with a pair of pliers and remove it. Rotate horizontally through 180 degrees. Reinstall the card and the correct fuse.

In the 120V setting, a 1.0A slow blow fuse is required. In the 240V setting, a 0.5A slow blow fuse is required.

GENERAL INFORMATION

BASIC PULSE CONTROL

This instrument can be triggered by its own internal clock, by an external TTL trigger signal, or by the front-panel MANUAL TRIGGER pushbutton. In any case, four output channels respond to the trigger: MAIN OUTPUT, SYNC, TTL and ECL. The MAIN OUTPUT channel is the signal that is normally applied to the load. Its amplitude and pulse width are variable. The SYNC pulse is a fixed-width TTL-level reference pulse used to trigger oscilloscopes or other measurement systems. When the delay is set to a positive value the SYNC pulse precedes the OUT pulse. When the delay is set to a negative value the SYNC pulse follows the OUT pulse.

The two logic outputs (TTL and ECL) are approximately coincident with the main output, but have fixed amplitudes and rise and fall times.

These pulses are illustrated below, assuming that internal triggering is used, and the delay mode is set to "MAIN OUT DELAYED":

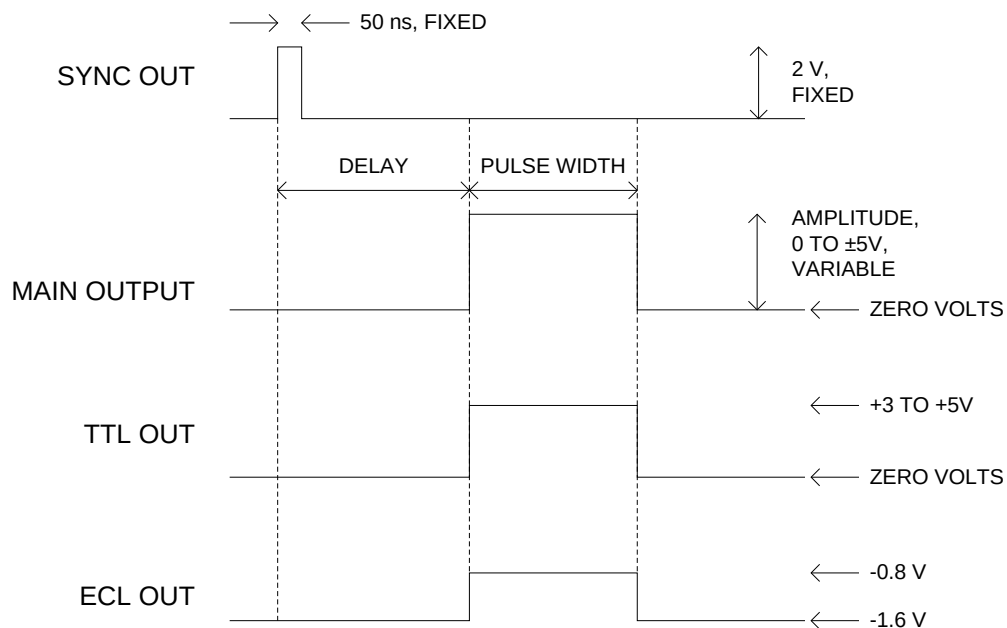

If the delay mode is set to "MAIN OUT ADVANCED", the order of the SYNC and OUT pulses is reversed:

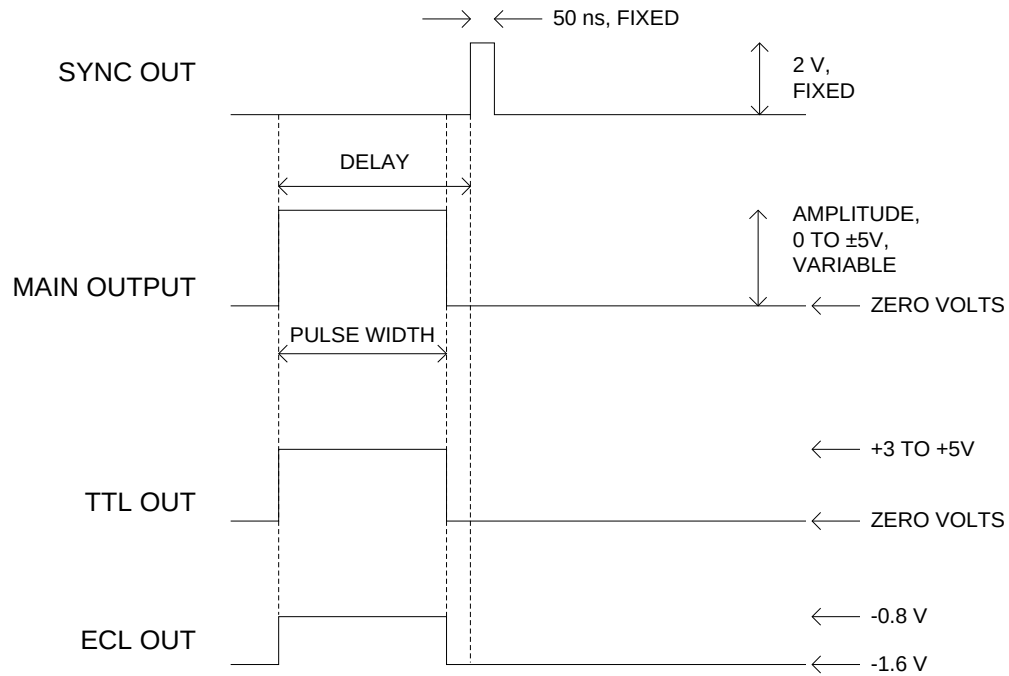

The next figure illustrates the relationship between the signals when an external TTL-level trigger is used (i.e., the REPETITION RATE switch is set to "EXT"), assuming that the delay mode is set to "MAIN OUT DELAYED":

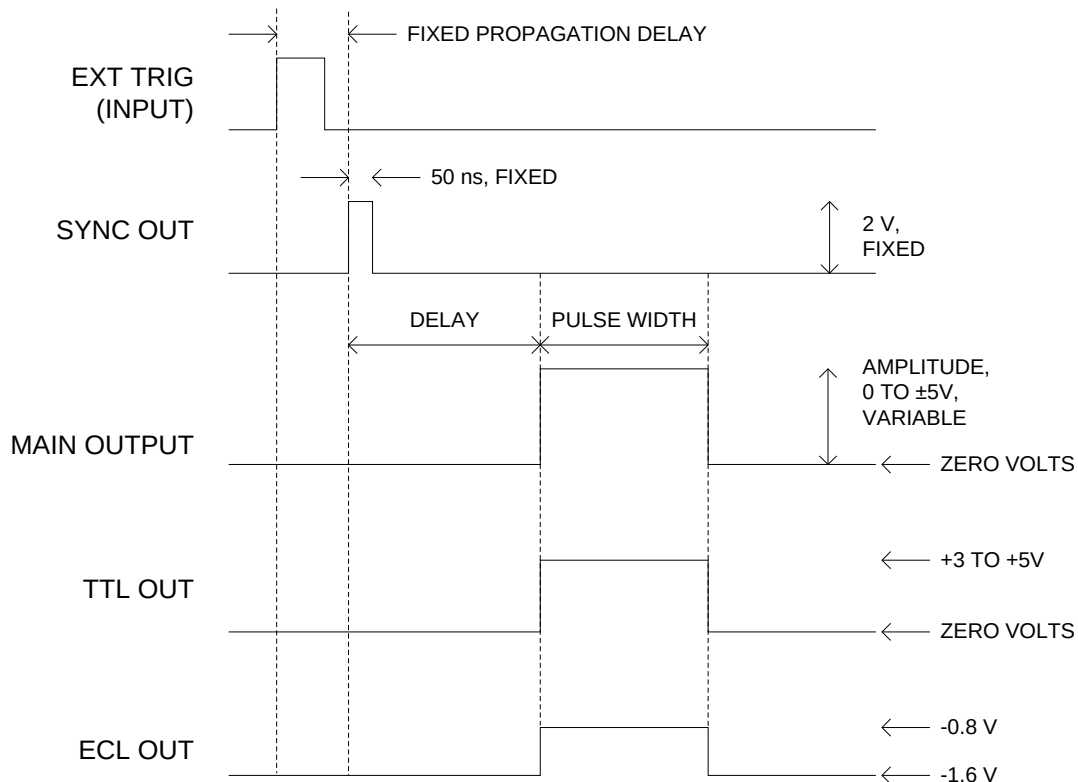

As before, if the delay mode is set to “MAIN OUT ADVANCED”, the order of the SYNC and OUT pulses is reversed.

TRIGGER MODES

This instrument has three trigger modes:

Internal Trigger: the instrument controls the trigger frequency, and generates the clock internally. This mode is enabled by setting the REPETITION RATE switch to one of the positions labeled with a frequency (i.e., 1kHz, 10 kHz, etc). The labeled frequency represents the upper end of that frequency range.

External Trigger: the instrument is triggered by an external TTL-level clock on the EXT TRIG connector. This mode is enabled by setting the REPETITION RATE switch to the “EXT” position.

Manual Trigger: the instrument is triggered by the front-panel “MANUAL TRIGGER” pushbutton. This mode is enabled by setting the REPETITION RATE switch to the “MAN” position.

GATING MODES

Triggering can be suppressed by a TTL-level signal on the GATE IN connector. If the GATE IN input is unconnected or TTL-high (3 to 5V), the instrument will trigger normally. If this input is TTL-low (0 Volts), triggering is inhibited.

MINIMIZING WAVEFORM DISTORTIONS

USE 50 Ω TRANSMISSION LINES AND LOADS

Connect the load to the pulse generator with 50 Ω transmission lines (e.g. RG-58 or RG-174 cable).

This instrument requires a 50 Ω load for proper operation. It will not properly drive a high-impedance load.

USE LOW-INDUCTANCE LOADS

Lenz's Law predicts that for an inductive voltage spike will be generated when the current through an inductance changes. Specifically, $V_{\text{SPIKE}} = L \frac{dI_{\text{LOAD}}}{dt}$, where L is the inductance, I_{LOAD} is the load current change, and t is time. For this reason, it is important to keep any parasitic in the load low. This means keeping wiring short, and using low inductance components. In particular, wire-wound resistors should be avoided.

MECHANICAL INFORMATION

TOP COVER REMOVAL

The interior of the instrument may be accessed by removing the four Phillips screws on the top panel. With the four screws removed, the top cover may be slid back (and off).

RACK MOUNTING

A rack mounting kit is available. The -R5 rack mount kit may be installed after first removing the one Phillips screw on the side panel adjacent to the front handle.

ELECTROMAGNETIC INTERFERENCE

To prevent electromagnetic interference with other equipment, all used outputs should be connected to shielded 50 Ω loads using shielded 50 Ω coaxial cables. Unused outputs should be terminated with shielded 50 Ω BNC terminators or with shielded BNC dust caps, to prevent unintentional electromagnetic radiation. All cords and cables should be less than 3m in length.

OPERATIONAL CHECK

This check is to confirm that the instrument is fully functional. In all tests, use 50 coaxial cabling. Two basic test arrangements are shown below. The first figure shows the general connection scheme for testing with a sampling oscilloscope.

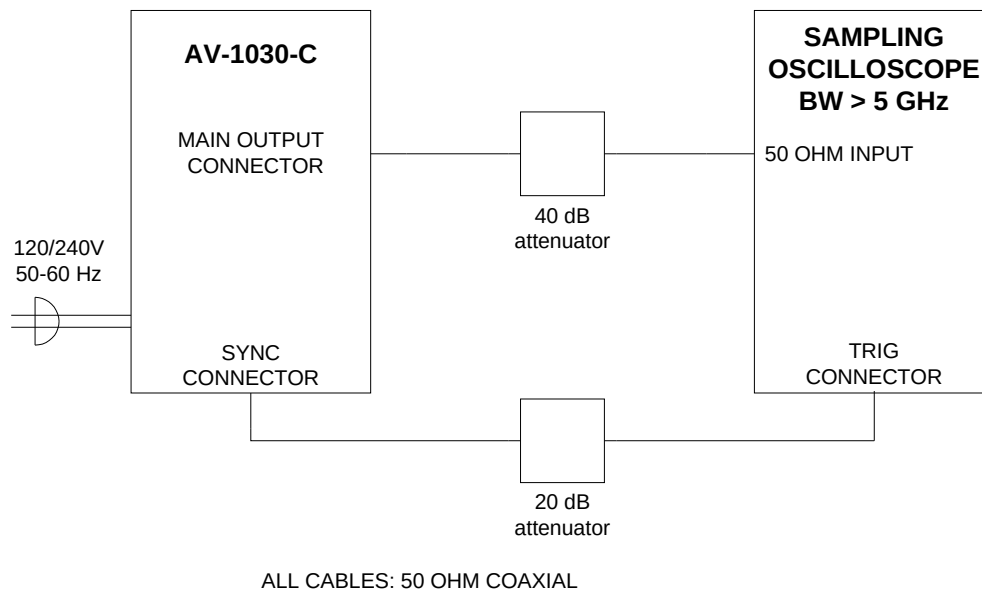

The use of the sampling oscilloscope will allow proper observation of the fast rising and falling edges of the waveform. However, if a high bandwidth sampling oscilloscope is not available, a slower real-time oscilloscope may be used, as shown below. Pronounced ringing may appear on the rising and falling edges due to the bandwidth limitations of the oscilloscope.

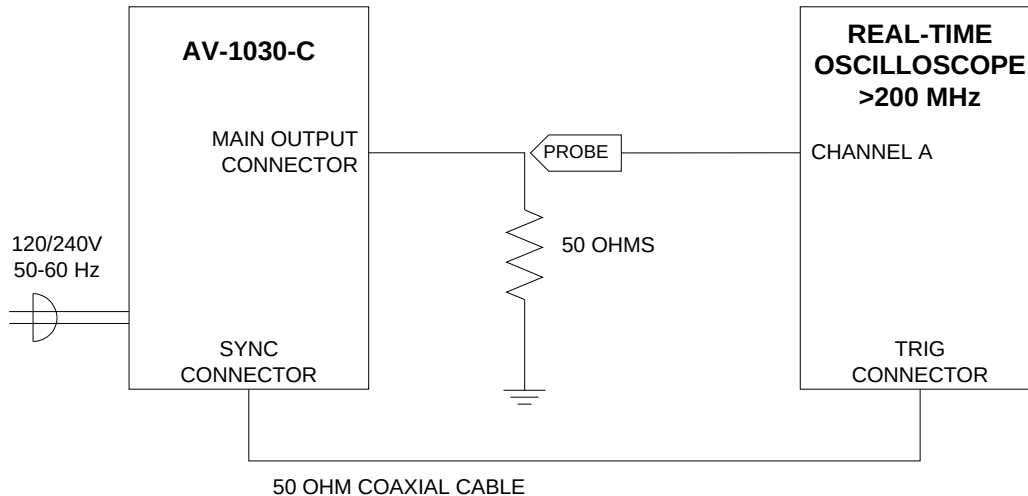

Set the AV-1030-C controls to the following values:

REPETITION RATE RANGE Switch: 100 kHz

REPETITION RATE Vernier: fully clockwise (maximum)

PULSE DELAY Switch: 100ns

PULSE DELAY Vernier: fully counter-clockwise (minimum)

PULSE WIDTH Switch: 100ns

PULSE WIDTH Vernier: fully clockwise (maximum)

AMPLITUDE Switch: +5V

AMPLITUDE Vernier: fully clockwise (maximum)

Set the oscilloscope to trigger externally. Then follow the instructions in the following table, and compare what is seen on the oscilloscope to what is described. Only approximate values are needed to confirm operation. (If the sampling oscilloscope test arrangement is used, the observed waveform will be reduced by a factor of 100 in amplitude, due to the use of a 40 dB attenuator.)

STEP	CONTROL	OPERATION	RESULTS
1	Power	Push in (ON)	+5V pulses at the main output, with period 10 μ s, pulse width 100ns, <10ns rise and fall times.
2	Repetition Rate	Rotate to MIN (1),	Period rises to about 100 μ s, then falls

	Vernier	then to MAX (10)	to about 10 s.
3	Delay Vernier	Rotate to MAX, then to MIN	Pulses shift to the right on the oscilloscope by 100ns, then back.
4	Pulse Width Vernier	Rotate to MIN, then to MAX	Pulses become very narrow (about 10ns wide), then return to 100ns pulse width.
5	Amplitude Switch	Switch to -5V, then to +5V	Pulses swing between 0 and -5V, then swing between 0 and +5V.
6	TTL OUT	Remove cable from MAIN OUTPUT connector, place on TTL OUT connector.	Oscilloscope shows pulses swinging between 0V and +3V, with period 10 s, and pulse width 100ns.
7	ECL OUT	Remove cable, place on ECL OUT connector	Oscilloscope shows pulses swinging between -0.8V and -1.6V, with period 10 s, and pulse width 100ns.

This completes the operational check.

TYPICAL WAVEFORMS

The following waveform photo shows the rising and falling edges of the main output with the AV-1030-C set to 100 kHz repetition rate, 100 ns pulse width, +5V amplitude, into a 50 Ohm load:

Top: Rising edge
Bottom: Falling edge

Both: 2 V/div (i.e., 20 mV/div 40 dB), 1 ns/div

REPAIR INSTRUCTIONS

BLOWN AC FUSE

If the entire instrument appears to have failed, unplug the power cord from the rear panel. Slide the plastic cover on the rear-panel power entry model to expose the fuse. Pull the plastic lever to eject the fuse. Replace the fuse if required. (See the “REAR PANEL CONTROLS” section for details.)

DAMAGED MAIN OUTPUT

The integrated circuit (IC) that generates the MAIN OUTPUT signal is installed in a socket, and may be replaced if it has been damaged through improper use. (The output stage does feature protection circuitry).

To replace this IC, turn off the instrument and remove the top cover. Locate the 24-pin IC labelled “U30” immediately behind the MAIN OUTPUT connector. This IC has a black clip-on heatsink. The IC can be removed by gently pulling it up and out of its socket.

Replacement ICs may be ordered directly from the manufacturer, Fairchild Semiconductor (www.fairchildsemi.com). The part number is KH103AI. The following part numbers are also acceptable substitutes: KH103AK, CLC103AI, and CLC103AM.

PERFORMANCE CHECK SHEET