



AVTECH ELECTROSYSTEMS LTD.

NANOSECOND WAVEFORM ELECTRONICS
SINCE 1975

P.O. BOX 265
OGDENSBURG, NY
U.S.A. 13669-0265

TEL: 888-670-8729 (USA & Canada) or +1-613-226-5772 (Intl)
FAX: 800-561-1970 (USA & Canada) or +1-613-226-2802 (Intl)

info@avtechpulse.com - <http://www.avtechpulse.com/>

BOX 5120, LCD MERIVALE
OTTAWA, ONTARIO
CANADA K2C 3H4

INSTRUCTIONS

MODEL AV-1030-B

0 TO ± 5 VOLTS, 10 MHz
GENERAL PURPOSE LAB PULSE GENERATOR
WITH 300 ps RISE TIMES
AND IEEE 488.2, RS-232 CONTROL

SERIAL NUMBER: _____

WARRANTY

Avtech Electrosystems Ltd. warrants products of its manufacture to be free from defects in material and workmanship under conditions of normal use. If, within one year after delivery to the original owner, and after prepaid return by the original owner, this Avtech product is found to be defective, Avtech shall at its option repair or replace said defective item. This warranty does not apply to units which have been disassembled, modified or subjected to conditions exceeding the applicable specifications or ratings. This warranty is the extent of the obligation assumed by Avtech with respect to this product and no other warranty or guarantee is either expressed or implied.

TECHNICAL SUPPORT

Phone: 888-670-8729 (USA & Canada) or +1-613-226-5772 (Intl)

Fax: 800-561-1970 (USA & Canada) or +1-613-226-2802 (Intl)

E-mail: info@avtechpulse.com

World Wide Web: <http://www.avtechpulse.com>

TABLE OF CONTENTS

WARRANTY.....	2
TECHNICAL SUPPORT.....	2
TABLE OF CONTENTS.....	3
INTRODUCTION.....	5
SPECIFICATIONS.....	6
EUROPEAN REGULATORY NOTES.....	7
EC DECLARATION OF CONFORMITY.....	7
DIRECTIVE 2002/95/EC (RoHS).....	7
DIRECTIVE 2002/96/EC (WEEE).....	7
INSTALLATION.....	9
VISUAL CHECK.....	9
POWER RATINGS.....	9
CONNECTION TO THE POWER SUPPLY.....	9
PROTECTION FROM ELECTRIC SHOCK.....	10
ENVIRONMENTAL CONDITIONS.....	10
LABVIEW DRIVERS.....	11
FUSES.....	12
AC FUSE REPLACEMENT.....	12
DC FUSE REPLACEMENT.....	13
FUSE RATINGS.....	13
FRONT PANEL CONTROLS.....	14
REAR PANEL CONTROLS.....	16
GENERAL INFORMATION.....	18
BASIC PULSE CONTROL.....	18
TRIGGER MODES.....	21
PULSE WIDTH MODES.....	22
PULSE WIDTH – AMPLITUDE INTERACTION.....	22
GATING MODES.....	22
MINIMIZING WAVEFORM DISTORTIONS.....	23
USE 50 OHM TRANSMISSION LINES AND LOADS.....	23
USE LOW-INDUCTANCE LOADS.....	23
TYPICAL WAVEFORMS.....	24
OPERATIONAL CHECK.....	25

PROGRAMMING YOUR PULSE GENERATOR.....	28
KEY PROGRAMMING COMMANDS.....	28
ALL PROGRAMMING COMMANDS.....	29
MECHANICAL INFORMATION.....	31
TOP COVER REMOVAL.....	31
RACK MOUNTING.....	31
ELECTROMAGNETIC INTERFERENCE.....	31
MAINTENANCE.....	32
REGULAR MAINTENANCE.....	32
CLEANING.....	32
WIRING DIAGRAMS.....	33
WIRING OF AC POWER.....	33
PCB 158E - LOW VOLTAGE POWER SUPPLY, 1/3.....	34
PCB 158E - LOW VOLTAGE POWER SUPPLY, 2/3.....	35
PCB 158E - LOW VOLTAGE POWER SUPPLY, 3/3.....	36
PCB 104D - KEYPAD / DISPLAY BOARD, 1/3.....	37
PCB 104D - KEYPAD / DISPLAY BOARD, 2/3.....	38
PCB 104D - KEYPAD / DISPLAY BOARD, 3/3.....	39
MAIN WIRING.....	40
PERFORMANCE CHECK SHEET.....	41

Manual Reference: /files/officefiles/instructword/av-1030/OBS/av-1030-b,edition2.odt.

Last modified February 29, 2024.

Copyright © 2024 Avtech Electrosystems Ltd, All Rights Reserved.

INTRODUCTION

The Avtech AV-1030-B is a versatile, general-purpose, low-cost, GPIB and RS232-equipped 10 MHz laboratory pulse generator, useful everywhere from undergraduate university classrooms to the most advanced research and development laboratories. This pulse generator features variable pulse repetition frequency (PRF), delay, pulse width, and amplitude. It also features an exceptionally fast 300 ps rise and 350 ps fall times.

The AV-1030-B is a highly flexible instrument. Aside from the internal trigger source, it can also be triggered or gated by external TTL-level signals. A front-panel pushbutton or a computer command can also be used to trigger the instrument. In the external trigger mode, the output pulse width can be set by the pulse generator, or it can be set to follow the input trigger's pulse width.

The main output has all of its characteristics variable, and is designed to drive 50 Ω loads. (A 50 Ω load is required for proper operation.) The main output is AC-coupled. Two logic outputs (TTL and ECL) have approximately the same timing characteristics as the main output, but have their amplitudes fixed at standard logic levels.

A synchronizing trigger output is also supplied, for triggering oscilloscopes and other test equipment (50 ns wide, +3V into 50 Ω).

Several points should be noted when operating this instrument:

- ◆ This unit *requires* a 50 ohm load.
- ◆ The maximum main output duty cycle is 10%.
- ◆ The main output is AC-coupled.

The AV-1030-B features front panel keyboard and adjust knob control of the output pulse parameters along with a four line by 40 character back-lit LCD display of the output amplitude, polarity, pulse width, pulse repetition frequency, source resistance and delay. The instrument includes memory to store up to four complete instrument setups. The operator may use the front panel or the computer interface to store a complete "snapshot" of all key instrument settings, and recall this setup at a later time.

This instrument is intended for use in research and development laboratories.

SPECIFICATIONS

Model:	AV-1030-B
GPIB and RS-232 control:	yes
Amplitude (to 50 Ohms) ¹ :	0 to ± 5 Volts
Output impedance:	50 Ohms
Rise time (20%-80%):	≤ 300 ps
Fall time (80%-20%):	≤ 350 ps
Pulse repetition frequency (PRF):	1 Hz to 10 MHz
Pulse width:	10 ns to 1 ms
Required load impedance:	50 Ohms
Jitter (Sync out to pulse out):	$\leq \pm 25$ ps ± 0.01 % of sync delay
Polarity (main output):	Positive or negative (switch-selectable)
Duty cycle (max):	10 %
Waveform aberrations:	Overshoot, undershoot, ringing and slope aberration are less than $\pm 10\%$ at amplitudes of 0.5V and higher ¹ with outputs terminating in 50 Ω .
Trigger required (Ext trig mode):	+ 5 Volts, ≥ 4 ns TTL
Trigger required (Gate in):	0 to 0.8 V (or grounded): No output + 2.8 V to + 5.0 V (or open): Normal output
Minimum propagation delay: (Ext Trig In to Main Out)	< 100 ns
Sync delay: (Sync Out to Main Out)	0 to ± 1 ms
Sync output:	+3 Volts, 50 ns, will drive 50 Ohm loads
Single pulse mode:	Manual Push Button
Signal connectors:	Main output: SMA Other: BNC
LabView Drivers:	-B units only: check http://www.avtechpulse.com/labview for availability and downloads
Power requirement:	100 - 240 Volts, 50 - 60 Hz
Dimensions (H x W x D):	100 mm x 430 mm x 375 mm (3.9" x 17" x 14.8")
Weight & chassis material:	4.5 kg (10 lb.), anodized aluminum, with blue plastic trim
Mounting & Temperature range:	Any, +5°C to +40°C

1) For operation at amplitudes of less than 5% of maximum, best results will be obtained by setting the amplitude near maximum and using external attenuators on the output.

EUROPEAN REGULATORY NOTES

EC DECLARATION OF CONFORMITY

We Avtech Electrosystems Ltd.
P.O. Box 5120, LCD Merivale
Ottawa, Ontario
Canada K2C 3H4

declare that this pulse generator meets the intent of Directive 89/336/EEC for Electromagnetic Compatibility. Compliance pertains to the following specifications as listed in the official Journal of the European Communities:

EN 50081-1 Emission

EN 50082-1 Immunity

and that this pulse generator meets the intent of the Low Voltage Directive 72/23/EEC as amended by 93/68/EEC. Compliance pertains to the following specifications as listed in the official Journal of the European Communities:

EN 61010-1:2001 Safety requirements for electrical equipment for measurement, control, and laboratory use



DIRECTIVE 2002/95/EC (RoHS)

This instrument is exempt from Directive 2002/95/EC of the European Parliament and of the Council of 27 January 2003 on the Restriction of the use of certain Hazardous Substances (RoHS) in electrical and electronic equipment. Specifically, Avtech instruments are considered "Monitoring and control instruments" (Category 9) as defined in Annex 1A of Directive 2002/96/EC. The Directive 2002/95/EC only applies to Directive 2002/96/EC categories 1-7 and 10, as stated in the "Article 2 - Scope" section of Directive 2002/95/EC.

DIRECTIVE 2002/96/EC (WEEE)

European customers who have purchased this equipment directly from Avtech will have completed a "WEEE Responsibility Agreement" form, accepting responsibility for WEEE

compliance (as mandated in Directive 2002/96/EC of the European Union and local laws) on behalf of the customer, as provided for under Article 9 of Directive 2002/96/EC.

Customers who have purchased Avtech equipment through local representatives should consult with the representative to determine who has responsibility for WEEE compliance. Normally, such responsibilities will lie with the representative, unless other arrangements (under Article 9) have been made.

Requirements for WEEE compliance may include registration of products with local governments, reporting of recycling activities to local governments, and financing of recycling activities.

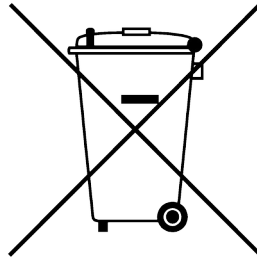

INSTALLATION

VISUAL CHECK

After unpacking the instrument, examine to ensure that it has not been damaged in shipment. Visually inspect all connectors, knobs, liquid crystal displays (LCDs), and the handles. Confirm that a power cord, a GPIB cable, and two instrumentation manuals (this manual and the “Programming Manual for -B Instruments”) are with the instrument. If the instrument has been damaged, file a claim immediately with the company that transported the instrument.

POWER RATINGS

This instrument is intended to operate from 100 - 240 V, 50 - 60 Hz.

The maximum power consumption is 57 Watts. Please see the “FUSES” section for information about the appropriate AC and DC fuses.

This instrument is an “Installation Category II” instrument, intended for operation from a normal single-phase supply.

CONNECTION TO THE POWER SUPPLY

An IEC-320 three-pronged recessed male socket is provided on the back panel for AC power connection to the instrument. One end of the detachable power cord that is supplied with the instrument plugs into this socket. The other end of the detachable power cord plugs into the local mains supply. Use only the cable supplied with the instrument. The mains supply must be earthed, and the cord used to connect the instrument to the mains supply must provide an earth connection. (The supplied cord does this.)

 Warning: Failure to use a grounded outlet may result in injury or death due to electric shock. This product uses a power cord with a ground connection. It must be connected to a properly grounded outlet. The instrument chassis is connected to the ground wire in the power cord.

The table below describes the power cord that is normally supplied with this instrument, depending on the destination region:

Destination Region	Description	Manufacturer	Part Number
Continental Europe	European CEE 7/7 "Schuko" 230V, 50Hz	Qualtek (http://www.qualtekusa.com)	319004-T01
United Kingdom	BS 1363, 230V, 50Hz	Qualtek (http://www.qualtekusa.com)	370001-E01
Switzerland	SEV 1011, 2 30V, 50Hz	Volex (http://www.volex.com)	2102H-C3-10
Israel	SI 32, 220V, 50Hz	Volex (http://www.volex.com)	2115H-C3-10
North America, and all other areas	NEMA 5-15, 120V, 60 Hz	Qualtek (http://www.qualtekusa.com)	312007-01

PROTECTION FROM ELECTRIC SHOCK

 Operators of this instrument must be protected from electric shock at all times. The owner must ensure that operators are prevented access and/or are insulated from every connection point. In some cases, connections must be exposed to potential human contact. Operators must be trained to protect themselves from the risk of electric shock. This instrument is intended for use by qualified personnel who recognize shock hazards and are familiar with safety precautions required to avoid possibly injury. In particular, operators should:

1. Keep exposed high-voltage wiring to an absolute minimum.
2. Wherever possible, use shielded connectors and cabling.
3. Connect and disconnect loads and cables only when the instrument is turned off.
4. Keep in mind that all cables, connectors, oscilloscope probes, and loads must have an appropriate voltage rating.
5. Do not attempt any repairs on the instrument, beyond the fuse replacement procedures described in this manual. Contact Avtech technical support (see page 2 for contact information) if the instrument requires servicing. Service is to be performed solely by qualified service personnel.

ENVIRONMENTAL CONDITIONS

This instrument is intended for use under the following conditions:

1. indoor use;
2. altitude up to 2 000 m;
3. temperature 5 °C to 40 °C;

4. maximum relative humidity 80 % for temperatures up to 31 °C decreasing linearly to 50 % relative humidity at 40 °C;
5. Mains supply voltage fluctuations up to ± 10 % of the nominal voltage;
6. no pollution or only dry, non-conductive pollution.

LABVIEW DRIVERS

A LabVIEW driver for this instrument is available for download on the Avtech web site, at <http://www.avtechpulse.com/labview>. A copy is also available in National Instruments' Instrument Driver Library at <http://www.natinst.com/>.

FUSES

This instrument contains four fuses. All are accessible from the rear-panel. Two protect the AC prime power input, and two protect the internal DC power supplies. The locations of the fuses on the rear panel are shown in the figure below:

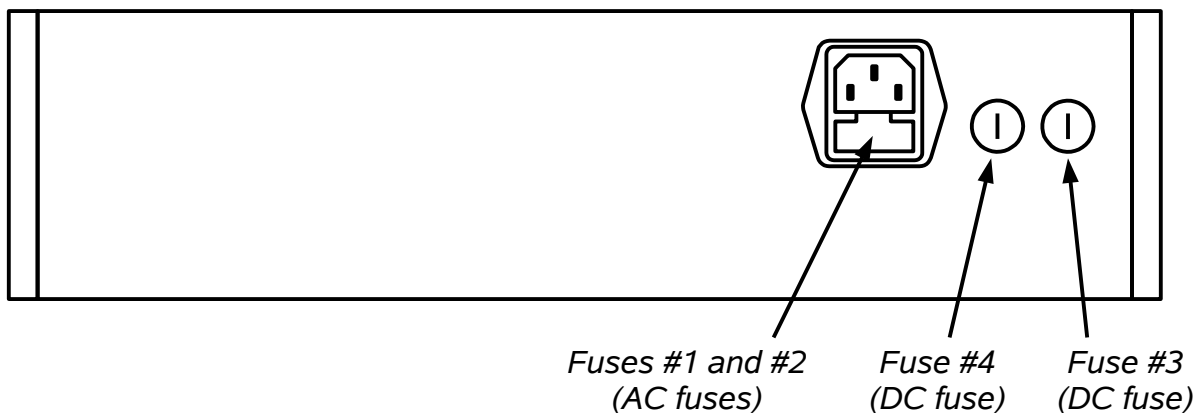

AC FUSE REPLACEMENT

To physically access the AC fuses, the power cord must be detached from the rear panel of the instrument. The fuse drawer may then be extracted using a small flat-head screwdriver, as shown below:

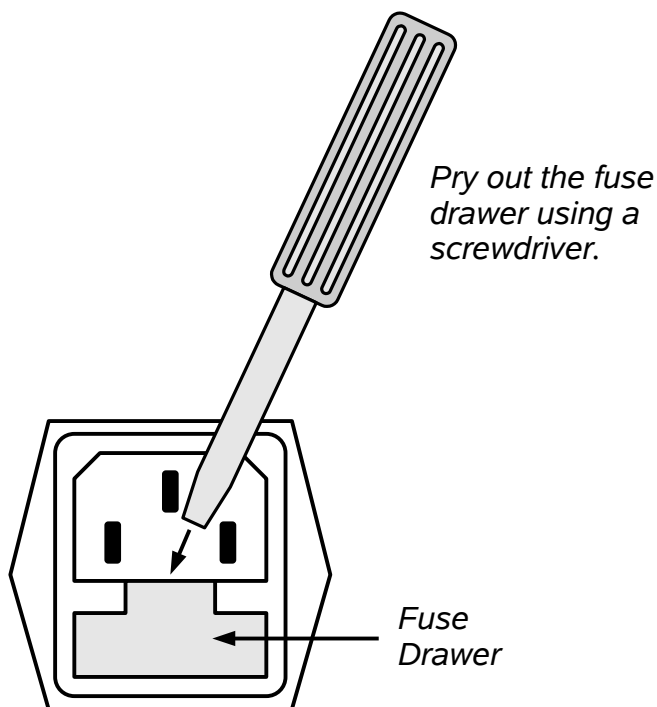

DC FUSE REPLACEMENT

The DC fuses may be replaced by inserting the tip of a flat-head screwdriver into the fuse holder slot, and rotating the slot counter-clockwise. The fuse and its carrier will then pop out.

FUSE RATINGS

The following table lists the required fuses:

Fuses	Nominal Mains Voltage	Rating	Case Size	Recommended Replacement Part	
				Littelfuse Part Number	Digi-Key Stock Number
#1, #2 (AC)	100-240V	0.5A, 250V, Time-Delay	5×20 mm	0218.500HXP	F2416-ND
#3 (DC)	N/A	1.6A, 250V, Time-Delay	5×20 mm	021801.6HXP	F2424-ND
#4 (DC)	N/A	Not used. A spare 1.6A fuse is installed here.			

The recommended fuse manufacturer is Littelfuse (<http://www.littelfuse.com>).

Replacement fuses may be easily obtained from Digi-Key (<http://www.digikey.com>) and other distributors.

FRONT PANEL CONTROLS

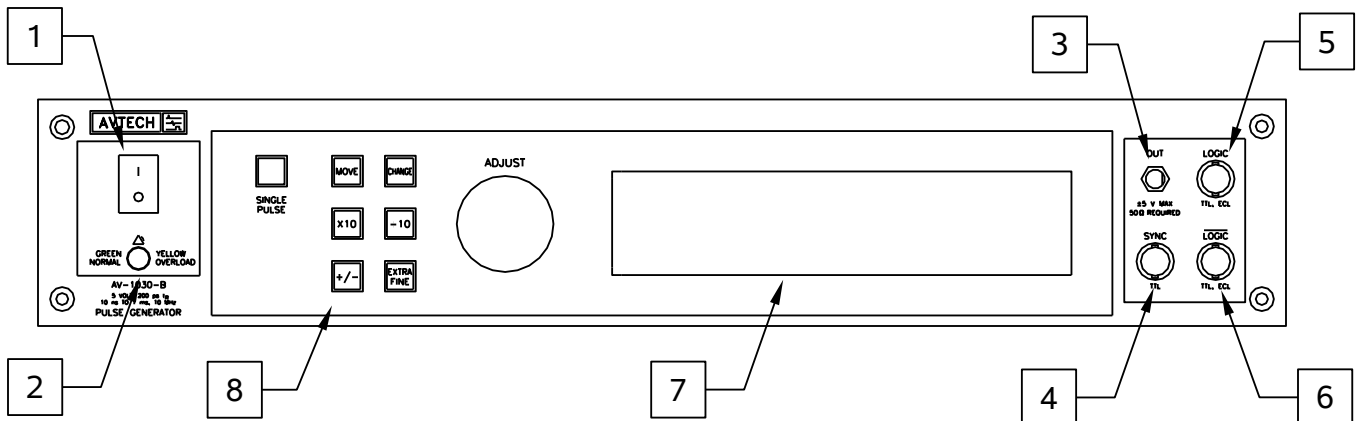

1. POWER Switch. This is the main power switch. When turning the instrument on, there may be a delay of several seconds before the instrument appears to respond.
2. OVERLOAD Indicator. When the instrument is powered, this indicator is normally green, indicating normal operation. If this indicator is yellow, an internal automatic overload protection circuit has been tripped. If the unit is overloaded (by operating at an exceedingly high duty cycle or by operating into a very low impedance), the protective circuit will disable the output of the instrument and turn the indicator light yellow. The light will stay yellow (i.e. output disabled) for about 5 seconds after which the instrument will attempt to re-enable the output (i.e. light green) for about 1 second. If the overload condition persists, the output will be disabled again (i.e. light yellow) for another 5 seconds. If the overload condition has been removed, the instrument will resume normal operation.

This overload indicator may flash yellow briefly at start-up. This is not a cause for concern.
3. OUT CONNECTOR. This SMA connector provides the main output signal, into load impedances of 50Ω. (A 50Ω load is *required*.) It can generate voltages of up to ±5V.
4. SYNC OUT. This connector supplies a SYNC output that can be used to trigger other equipment, particularly oscilloscopes. This signal leads (or lags) the main output by a duration set by the "DELAY" controls and has an approximate amplitude of +3 Volts to $R_L > 1\text{k}\Omega$ with a pulse width of approximately 50 ns.
5. LOGIC Output. The signal on this output has approximately the timing parameters as the main output (i.e. frequency, pulse width, and delay) but the amplitude is fixed at either TTL logic levels (0 and +5V, approximately) or ECL logic levels (-1.6V and -0.8V, approximately), depending on the settings. When using this output, it is recommended that it be terminated with a 50Ω load.
6. LOGIC-Complement Output. The signal on this output is the logical complement of the signal on the LOGIC output (item 4). That is, the high and low logic levels are

reversed.

7. LIQUID CRYSTAL DISPLAY (LCD). This LCD is used in conjunction with the keypad to change the instrument settings. Normally, the main menu is displayed, which lists the key adjustable parameters and their current values. The "Programming Manual for -B Instruments" describes the menus and submenus in detail.
8. KEYPAD.

Control Name	Function
MOVE	This moves the arrow pointer on the display.
CHANGE	This is used to enter the submenu, or to select the operating mode, pointed to by the arrow pointer.
×10	If one of the adjustable numeric parameters is displayed, this increases the setting by a factor of ten.
÷10	If one of the adjustable numeric parameters is displayed, this decreases the setting by a factor of ten.
+/-	If one of the adjustable numeric parameters is displayed, and this parameter can be both positive or negative, this changes the sign of the parameter.
EXTRA FINE	This changes the step size of the ADJUST knob. In the extra-fine mode, the step size is twenty times finer than in the normal mode. This button switches between the two step sizes.
ADJUST	This large knob adjusts the value of any displayed numeric adjustable values, such as frequency, pulse width, etc. The adjust step size is set by the "EXTRA FINE" button. When the main menu is displayed, this knob can be used to move the arrow pointer.

REAR PANEL CONTROLS

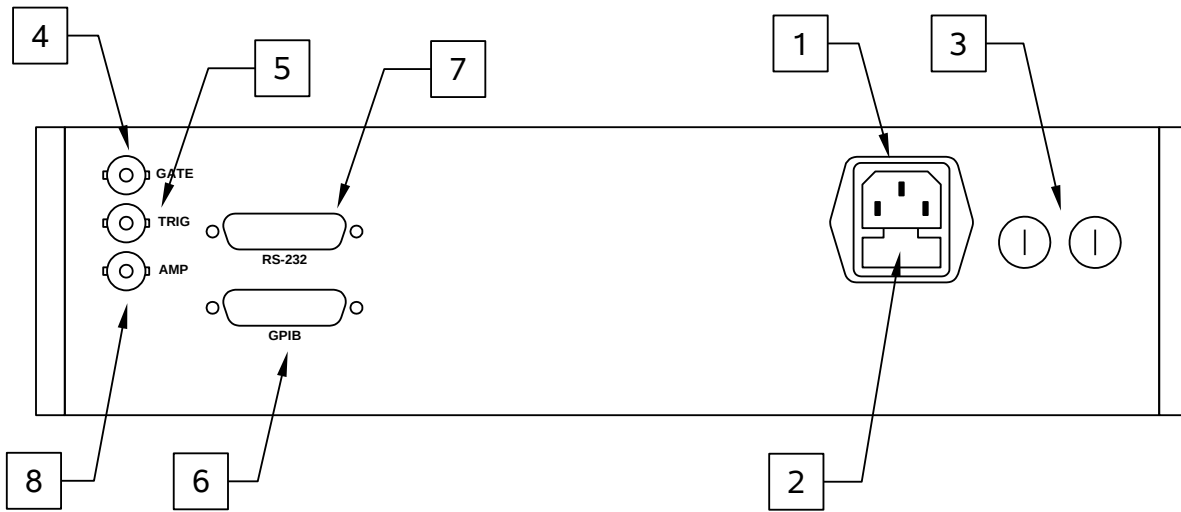

1. AC POWER INPUT. An IEC-320 C14 three-pronged recessed male socket is provided on the back panel for AC power connection to the instrument. One end of the detachable power cord that is supplied with the instrument plugs into this socket.
2. AC FUSE DRAWER. The two fuses that protect the AC input are located in this drawer. Please see the “FUSES” section of this manual for more information.
3. DC FUSES. These two fuses protect the internal DC power supplies. Please see the “FUSES” sections of this manual for more information.
4. GATE. This TTL-level (0 and +5V) logic input can be used to gate the triggering of the instrument. This input can be either active high or active low, depending on the front panel settings or programming commands. (The instrument triggers normally when this input is unconnected). When set to active high mode, this input is pulled-down to ground by a 1 k Ω resistor. When set to active low mode, this input is pulled-up to +5V by a 1 k Ω resistor.
5. TRIG. This TTL-level (0 and +5V) logic input can be used to trigger the instrument, if the instrument is set to triggering externally. The instrument triggers on the rising edge of this input. The input impedance of this input is 1 k Ω . (Depending on the length of cable attached to this input, and the source driving it, it may be desirable to add a coaxial 50 Ohm terminator to this input to provide a proper transmission line termination. The Pasternack (www.pasternack.com) PE6008-50 BNC feed-thru 50 Ohm terminator is suggested for this purpose.)

When triggering externally, the instrument can be set such that the output pulse width tracks the pulse width on this input, or the output pulse width can be set independently.

6. GPIB Connector. A standard GPIB cable can be attached to this connector to allow the instrument to be computer-controlled. See the “Programming Manual for -B Instruments” for more details on GPIB control.
7. RS-232 Connector. A standard serial cable with a 25-pin male connector can be attached to this connector to allow the instrument to be computer-controlled. See the “Programming Manual for -B Instruments” for more details on RS-232 control.
8. AMP Connector. This connector is not used on the AV-1030-B.

If any additional items are present, they are unused or inactive.

GENERAL INFORMATION

BASIC PULSE CONTROL

This instrument can be triggered by its own internal clock or by an external TTL trigger signal. In either case, four output channels respond to the trigger: OUT, SYNC, LOGIC, and LOGIC-Complement.

- **OUT.** This is the main output. The pulse width, amplitude, and offset are all adjustable. The maximum output voltage is $\pm 10\text{V}$. (This voltage is reduced by a factor of two if the output impedance is set at 50Ω , and a 50Ω load is used.)
- **SYNC.** The SYNC pulse is a fixed-width TTL-level reference pulse used to trigger oscilloscopes or other measurement systems. When the delay is set to a positive value the SYNC pulse precedes the OUT pulse. When the delay is set to a negative value the SYNC pulse follows the OUT pulse.
- **LOGIC.** The signal on this output has approximately the timing parameters as the main output (i.e. frequency, pulse width, and delay) but the amplitude is fixed at either TTL logic levels (0 and +5V, approximately) or ECL logic levels (-1.6V and -0.8V, approximately), depending on the settings. When using this output, it is recommended that it be terminated with a 50Ω load.
- **LOGIC-Complement Output.** The signal on this output is the logical complement of the signal on the LOGIC output. That is, the high and low logic levels are reversed.

These pulses are illustrated below, assuming internal triggering and a positive delay:

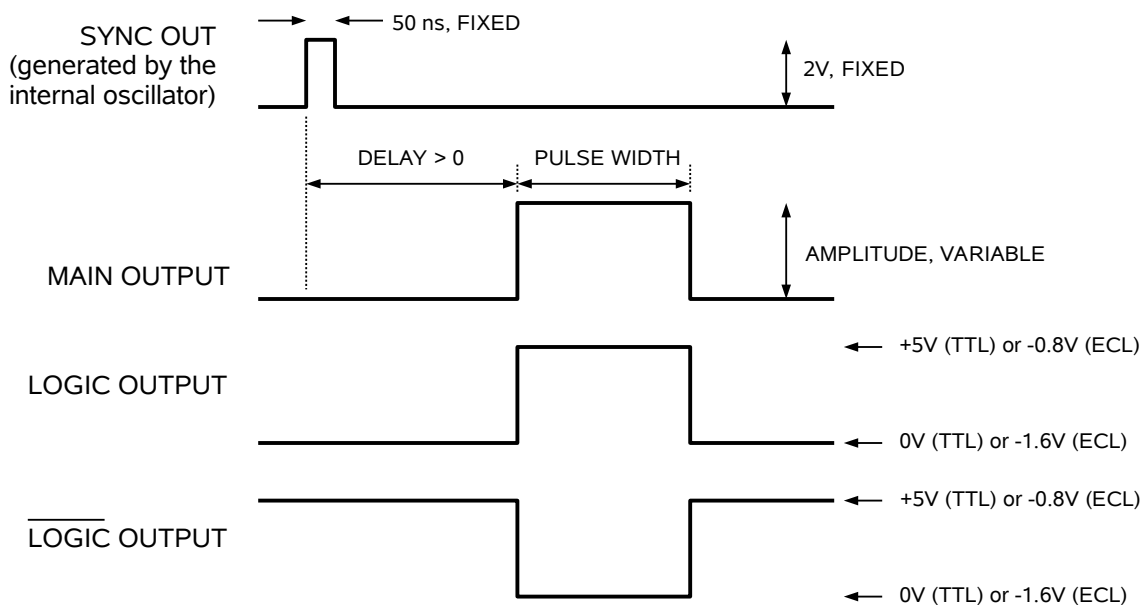

If the delay is negative, the order of the SYNC and OUT pulses is reversed:

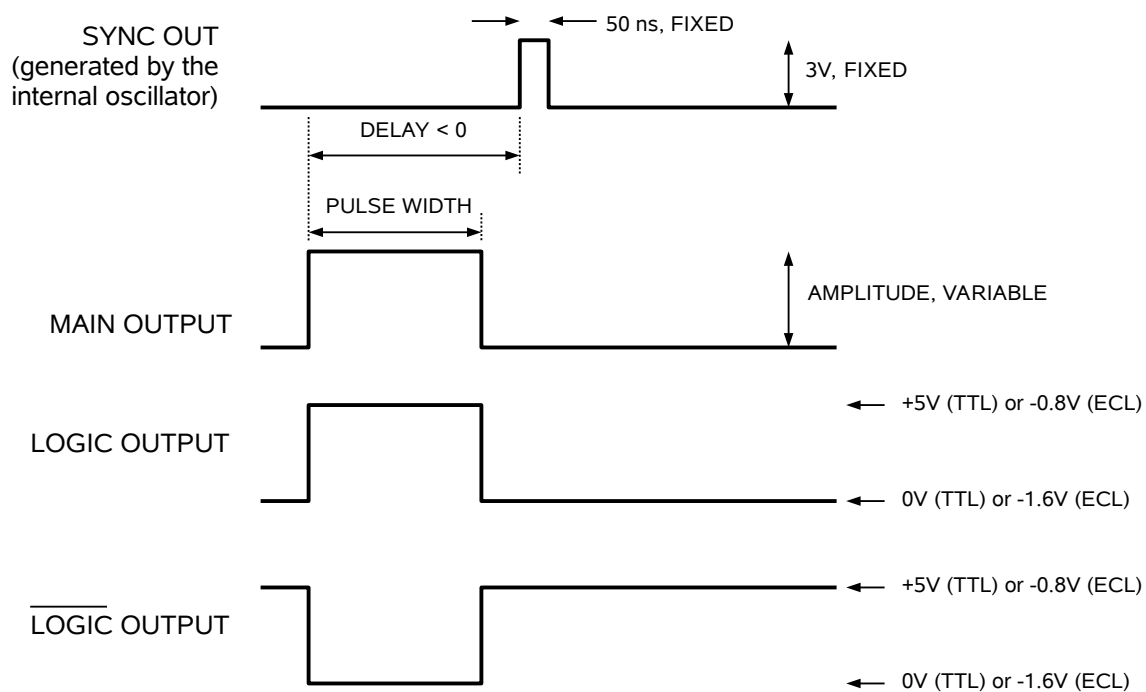

The next figure illustrates the relationship between the signals when an external TTL-level trigger is used:

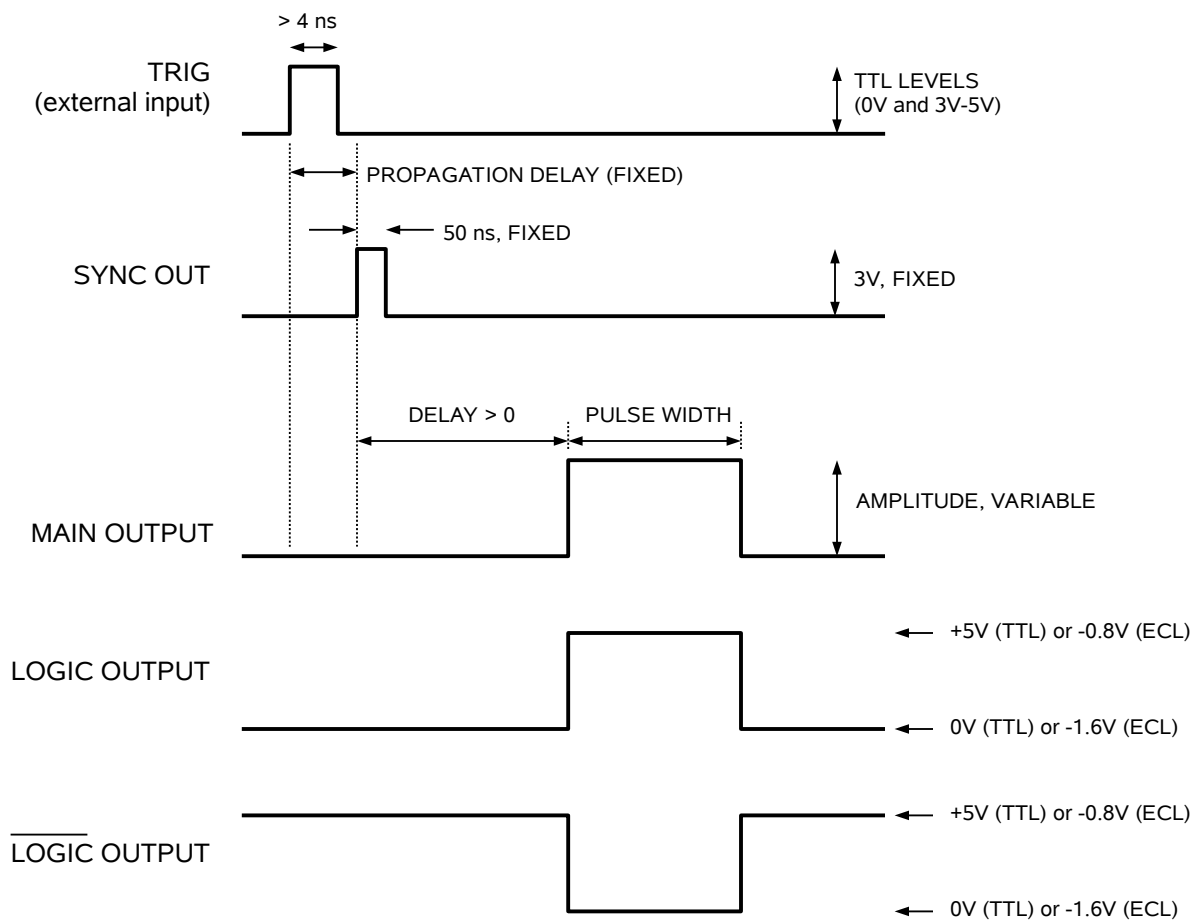

As before, if the delay is negative, the order of the SYNC and OUT pulses is reversed.

The last figure illustrates the relationship between the signal when an external TTL-level trigger is used in the $PW_{IN}=PW_{OUT}$ mode. In this case, the output pulse width equals the external trigger's pulse width (approximately), and the delay circuit is bypassed:

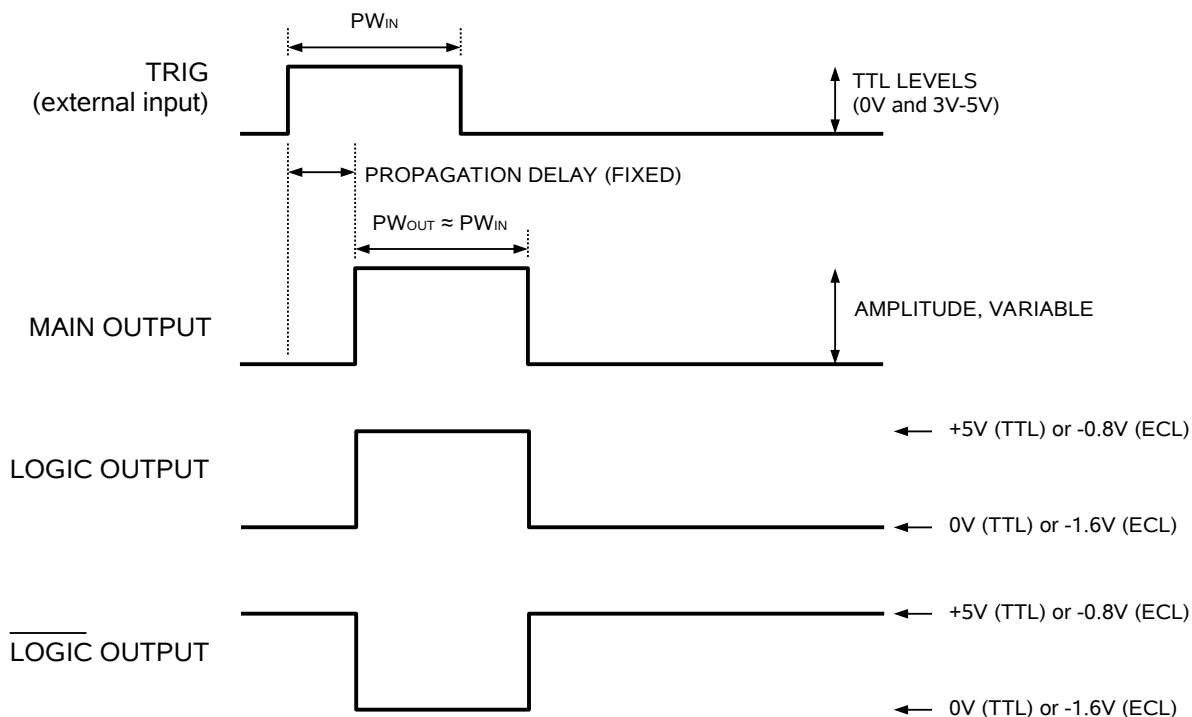

The delay, pulse width, and frequency (when in the internal mode), of the OUT pulse can be varied with front panel controls or via the GPIB or RS-232 computer interfaces.

TRIGGER MODES

This instrument has four trigger modes:

- Internal Trigger: the instrument controls the trigger frequency, and generates the clock internally.
- External Trigger: the instrument is triggered by an external TTL-level clock on the back-panel TRIG connector.
- Manual Trigger: the instrument is triggered by the front-panel "SINGLE PULSE" pushbutton.
- Hold Trigger: the instrument is set to not trigger at all.

These modes can be selected using the front panel trigger menu, or by using the appropriate programming commands. (See the "Programming Manual for -B Instruments" for more details.)

PULSE WIDTH MODES

This instrument has two pulse width modes:

- Normal: the instrument controls the output pulse width.
- $PW_{IN}=PW_{OUT}$: the output pulse width equals the pulse width of the trigger signal on the “TRIG” connector. The instrument must be in the external trigger mode.

These modes can be selected using the front panel pulse width menu, or by using the appropriate programming commands. (See the “Programming Manual for -B Instruments” for more details.)

PULSE WIDTH – AMPLITUDE INTERACTION

The pulse width may vary over a small range (± 5 ns) as the amplitude is varied. This is normal, and unavoidable.

GATING MODES

Triggering can be suppressed by a TTL-level signal on the rear-panel GATE connector. The instrument can be set to stop triggering when this input high or low, using the front-panel gate menu or the appropriate programming commands. This input can also be set to act synchronously or asynchronously. When set to asynchronous mode, the GATE will disable the output immediately. Output pulses may be truncated. When set to synchronous mode, the output will complete the full pulse width if the output is high, and then stop triggering. No pulses are truncated in this mode.

MINIMIZING WAVEFORM DISTORTIONS

USE 50 OHM TRANSMISSION LINES AND LOADS

Connect the load to the pulse generator with 50 Ω transmission lines (e.g. RG-58 or RG-174 cable).

This instrument requires a 50 Ω load for proper operation. It will not properly drive a high-impedance load.

USE LOW-INDUCTANCE LOADS

Lenz's Law predicts that for an inductive voltage spike will be generated when the current through an inductance changes. Specifically, $V_{\text{SPIKE}} = L \times di_{\text{LOAD}}/dt$, where L is the inductance, i_{LOAD} is the load current change, and t is time. For this reason, it is important to keep any parasitic in the load low. This means keeping wiring short, and using low inductance components. In particular, wire-wound resistors should be avoided.

TYPICAL WAVEFORMS

The following waveform photo shows the rising and falling edges of the main output with the AV-1030-B set to 100 kHz repetition rate, 100 ns pulse width, +5V amplitude, into a 50 Ohm load:

Top: Rising edge
Bottom: Falling edge

Both: 2 V/div (i.e., 20 mV/div 40 dB), 1 ns/div

OPERATIONAL CHECK

This section describes a sequence to confirm the basic operation of the instrument. It should be performed after receiving the instrument. It is a useful learning exercise as well.

Before proceeding with this procedure, finish reading this instruction manual thoroughly. Then read the “Local Control” section of the “Programming Manual for -B Instruments” thoroughly. The “Local Control” section describes the front panel controls used in this operational check - in particular, the MOVE, CHANGE, and ADJUST controls.

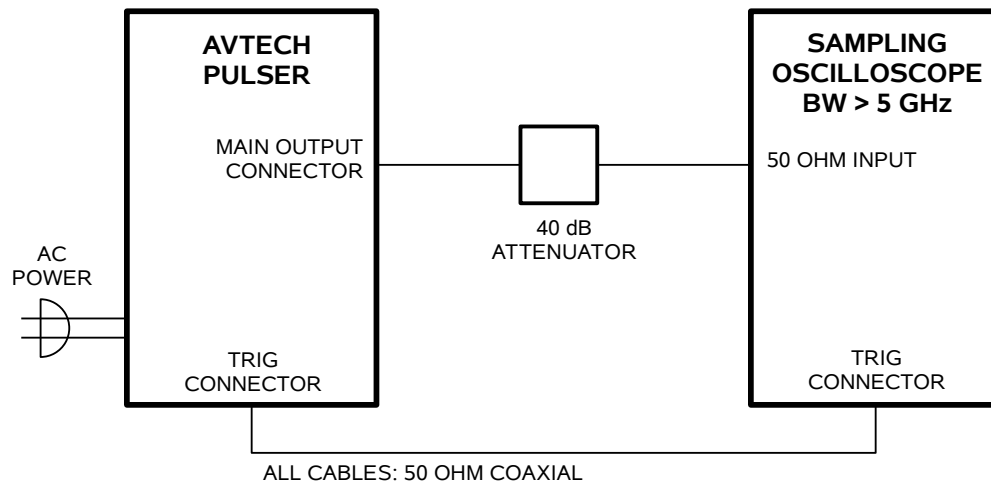

BASIC TEST ARRANGEMENT

1. Connect the pulse generator to a sampling oscilloscope as shown above. Note that:
 - a) The use of 40 dB attenuator at the sampling scope vertical input channel will insure a peak input signal to the sampling scope of less than 1 Volt. Factory tests are conducted using Midwest Microwave model ATT-0444-20-SMA-02 attenuators.
 - b) The TRIG output channel provides TTL level signals (approximately 0 and +3V). To avoid overdriving the TRIG input channel of some scopes, a 20 dB attenuator may be required at the input of the scope trigger channel.
 - c) The bandwidth capability of components and instruments used to display the pulse generator output signal (attenuators, cables, connectors, etc.) should exceed 5 GHz.

d) Set the oscilloscope to trigger externally with the vertical setting at 50 mV/div and the horizontal setting at 10 ns/div.

2. Turn on the AV-1030-B. The main menu will appear on the LCD.

3. To set the AV-1030-B to trigger from the internal clock at a PRF of 10 kHz:

a) The arrow pointer should be pointing at the frequency menu item. If it is not, press the MOVE button until it is.

b) Press the CHANGE button. The frequency submenu will appear. Rotate the ADJUST knob until the frequency is set at 10 kHz.

c) The arrow pointer should be pointing at the "Internal" choice. If it is not, press MOVE until it is.

d) Press CHANGE to return to the main menu.

4. To set the delay to 100 ns:

a) Press the MOVE button until the arrow pointer is pointing at the delay menu item.

b) Press the CHANGE button. The delay submenu will appear. Rotate the ADJUST knob until the delay is set at 100 ns.

c) The arrow pointer should be pointing at the "Normal" choice. If it is not, press MOVE until it is.

d) Press CHANGE to return to the main menu.

5. To set the pulse width to 50 ns:

a) Press the MOVE button until the arrow pointer is pointing at the pulse width menu item.

b) Press the CHANGE button. The pulse width submenu will appear. Rotate the ADJUST knob until the pulse width is set at 50 ns.

c) The arrow pointer should be pointing at the "Normal" choice. If it is not, press MOVE until it is.

d) Press CHANGE to return to the main menu.

6. At this point, nothing should appear on the oscilloscope.

7. To enable the output:

- a) Press the MOVE button until the arrow pointer is pointing at the output menu item.
- b) Press the CHANGE button. The output submenu will appear.
- c) Press MOVE until the arrow pointer is pointing at the "ON" choice.
- d) Press CHANGE to return to the main menu.

8. To change the output amplitude:

- a) Press the MOVE button until the arrow pointer is pointing at the amplitude menu item.
- b) Press the CHANGE button. The amplitude submenu will appear. Rotate the ADJUST knob until the amplitude is set at +5V.
- c) Observe the oscilloscope. You should see 50 ns wide, 5V pulses. If you do not, you may need to adjust the delay setting to a value more compatible with your sampling oscilloscope. Repeat step 4 if required. You may also need to adjust the sampling scope controls.
- d) Rotate the ADJUST knob. The amplitude as seen on the oscilloscope should vary. Return it to 5V.
- e) Press the +/- button on the front panel. The amplitude as seen on the oscilloscope should flip polarity, to -5V.
- f) Press CHANGE to return to the main menu.

This completes the operational check.

PROGRAMMING YOUR PULSE GENERATOR

KEY PROGRAMMING COMMANDS

The “Programming Manual for -B Instruments” describes in detail how to connect the pulse generator to your computer, and the programming commands themselves. A large number of commands are available; however, normally you will only need a few of these. Here is a basic sample sequence of commands that might be sent to the instrument after power-up:

*rst	(resets the instrument)
trigger:source internal	(selects internal triggering)
output:type TTL	(sets the logic outputs to TTL mode)
frequency 1000 Hz	(sets the frequency to 1000 Hz)
pulse:width 10 us	(sets the pulse width to 10 us)
pulse:delay 1 us	(sets the delay to 1 us)
volt:ampl 5	(sets the amplitude to 5 V)
output on	(turns on the output)

For triggering a single event, this sequence would be more appropriate:

*rst	(resets the instrument)
trigger:source hold	(turns off all triggering)
output:type TTL	(sets the logic outputs to TTL mode)
pulse:width 100 ns	(sets the pulse width to 100 ns)
output on	(turns on the output)
volt:ampl 5	(sets the amplitude to 5 V)
trigger:source immediate	(generates a single non-repetitive trigger event)
trigger:source hold	(turns off all triggering)
output off	(turns off the output)

To set the instrument to trigger from an external TTL signal applied to the rear-panel TRlg connector, use:

*rst	(resets the instrument)
trigger:source external	(selects external triggering)
output:type TTL	(sets the logic outputs to TTL mode)
pulse:width 10 us	(sets the pulse width to 10 us)
pulse:delay 1 us	(sets the delay to 1 us)
volt:ampl 5	(sets the amplitude to 5 V)
output on	(turns on the output)

In the above example, the pulse width of the output was set by a programming command. To set the output pulse width to track the trigger pulse width in external mode, use:

*rst	(resets the instrument)
trigger:source external	(selects internal triggering)
pulse:width in	($PW_{OUT} = PW_{IN}$)
output:type TTL	(sets the logic outputs to TTL mode)
volt:ampl 5	(sets the amplitude to 5 V)
output on	(turns on the output)

These commands will satisfy 90% of your programming needs.

ALL PROGRAMMING COMMANDS

For more advanced programmers, a complete list of the available commands is given below. These commands are described in detail in the “Programming Manual for -B Instruments”. (Note: this manual also includes some commands that are not implemented in this instrument. They can be ignored.)

<u>Keyword</u>	<u>Parameter</u>	<u>Notes</u>
DIAGnostic:		
:AMPLitude		
:CALibration	<numeric value>	[no query form]
:OFFSet		
:CALibration	<numeric value>	[no query form]
LOCAL		
OUTPut:		
:[STATE]	<boolean value>	
:PROTection		
:TRIPped?		[query only]
:TYPE	TTL ECL	
REMOTE		
[SOURce]:		
:FREQuency		
[:CW FIXed]	<numeric value>	
[SOURce]:		
:PULSe		
:PERiod	<numeric value>	
:WIDTh	<numeric value>	
:DCYCLE	<numeric value>	
:HOLD	WIDTh DCYCLE	
:DELay	<numeric value>	
:DOUBle		
:[STATE]	<boolean value>	
:DELay	<numeric value>	
:GATE		
:TYPE	ASYNc SYNc	
:LEVel	HIGH LOW	
[SOURce]:		

:VOLTage		
[:LEVel]		
[:IMMediate]		
[:AMPLitude]	<numeric value>	
:PROTection		
:TRIPped?		[query only]
STATUS:		
:OPERation		
:[EVENT]?		[query only, always returns "0"]
:CONDition?		[query only, always returns "0"]
:ENABle	<numeric value>	[implemented but not useful]
:QUESTionable		
:[EVENT]?		[query only, always returns "0"]
:CONDition?		[query only, always returns "0"]
:ENABle	<numeric value>	[implemented but not useful]
SYSTem:		
:COMMunicate		
:GPIB		
:ADDReSS	<numeric value>	
:SERial		
:CONTRol		
:RTS	ON IBFull RFR	
:[RECeive]		
:BAUD	1200 2400 4800 9600	
:BITS	7 8	
:ECHO	<boolean value>	
:PARity		
:[TYPE]	EVEN ODD NONE	
:SBITS	1 2	
:ERRor		
:[NEXT]?		[query only]
:COUNT?		[query only]
:VERSion?		[query only]
TRIGger:		
:SOURce	INTernal EXTernal MANual HOLD IMMEDIATE	
*CLS		[no query form]
*ESE	<numeric value>	
*ESR?		[query only]
*IDN?		[query only]
*OPC		
*SAV	0 1 2 3	[no query form]
*RCL	0 1 2 3	[no query form]
*RST		[no query form]
*SRE	<numeric value>	
*STB?		[query only]
*TST?		[query only]
*WAI		[no query form]

MECHANICAL INFORMATION

TOP COVER REMOVAL

If necessary, the interior of the instrument may be accessed by removing the four Phillips screws on the top panel. With the four screws removed, the top cover may be slid back (and off).

 Always disconnect the power cord and allow the instrument to sit unpowered for 10 minutes before opening the instrument. This will allow any internal stored charge to discharge.

There are no user-adjustable internal circuits. For repairs other than fuse replacement, please contact Avtech (info@avtechpulse.com) to arrange for the instrument to be returned to the factory for repair. Service is to be performed solely by qualified service personnel.

 Caution: High voltages are present inside the instrument during normal operation. Do not operate the instrument with the cover removed.

RACK MOUNTING

A rack mounting kit is available. The -R5 rack mount kit may be installed after first removing the one Phillips screw on the side panel adjacent to the front handle.

ELECTROMAGNETIC INTERFERENCE

To prevent electromagnetic interference with other equipment, all used outputs should be connected to shielded loads using shielded coaxial cables. Unused outputs should be terminated with shielded coaxial terminators or with shielded coaxial dust caps, to prevent unintentional electromagnetic radiation. All cords and cables should be less than 3m in length.

MAINTENANCE

REGULAR MAINTENANCE

This instrument does not require any regular maintenance.

On occasion, one or more of the four rear-panel fuses may require replacement. All fuses can be accessed from the rear panel. See the “FUSES” section for details.

CLEANING

If desired, the interior of the instrument may be cleaned using compressed air to dislodge any accumulated dust. (See the “TOP COVER REMOVAL” section for instructions on accessing the interior.) No other cleaning is recommended.

PCB 158E - LOW VOLTAGE POWER SUPPLY, 1/3

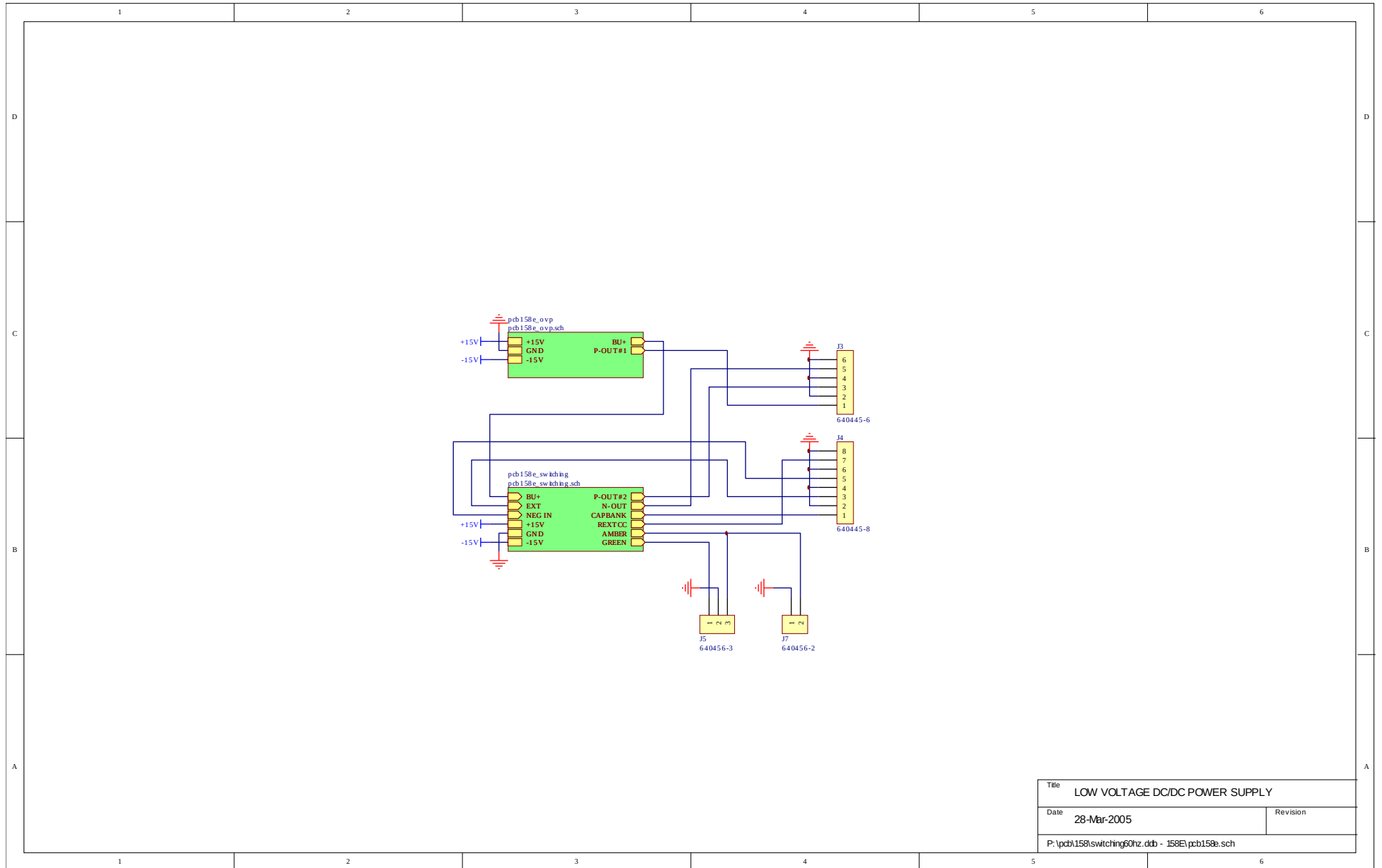

Title		LOW VOLTAGE DC/DC POWER SUPPLY
Date	28-Mar-2005	Revision
P:\pcb\158\switching60hz.ddb - 158E.pcb158e.sch		

PCB 158E - LOW VOLTAGE POWER SUPPLY, 3/3

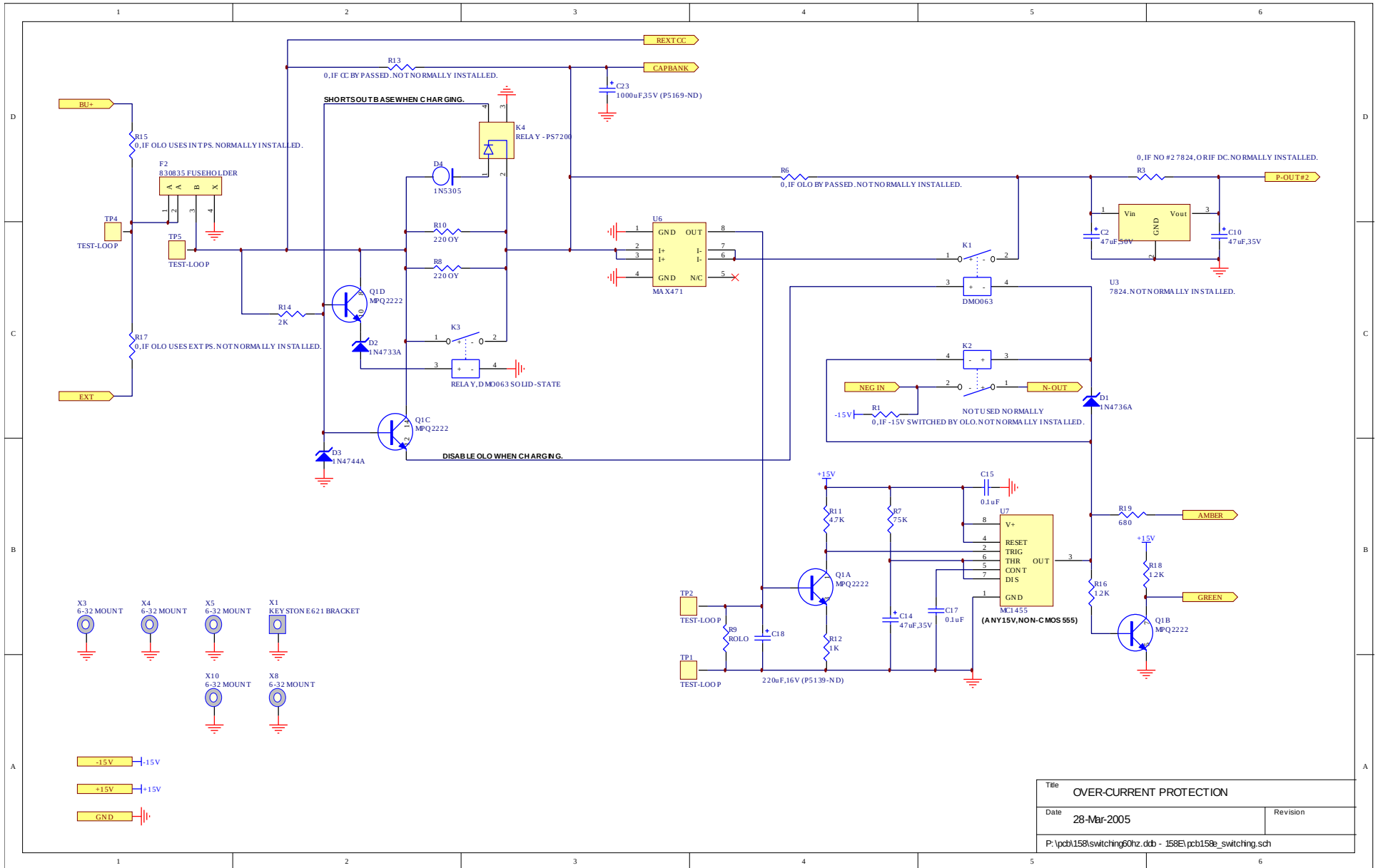

Title		OVER-CURRENT PROTECTION
Date	28-Mar-2005	Revision
P:\pcb\158\switching60hz.ddb - 158E.pcb158e_switching.sch		

PCB 104D - KEYPAD / DISPLAY BOARD, 1/3

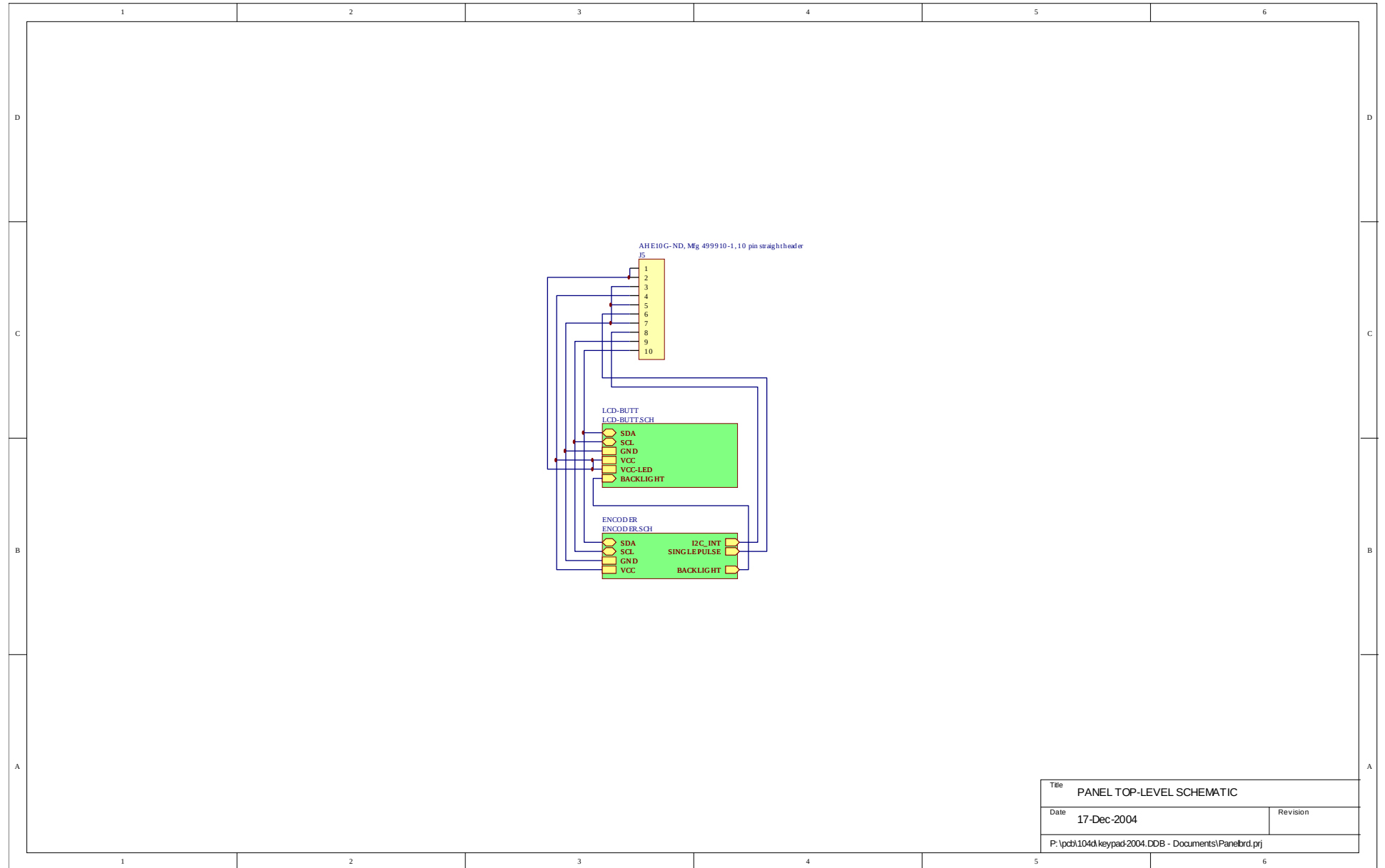

Title		PANEL TOP-LEVEL SCHEMATIC	
Date	17-Dec-2004	Revision	
P:\pcb104d\keypad2004.DDB - Documents\Panelbrd.prj			

PCB 104D - KEYPAD / DISPLAY BOARD, 2/3

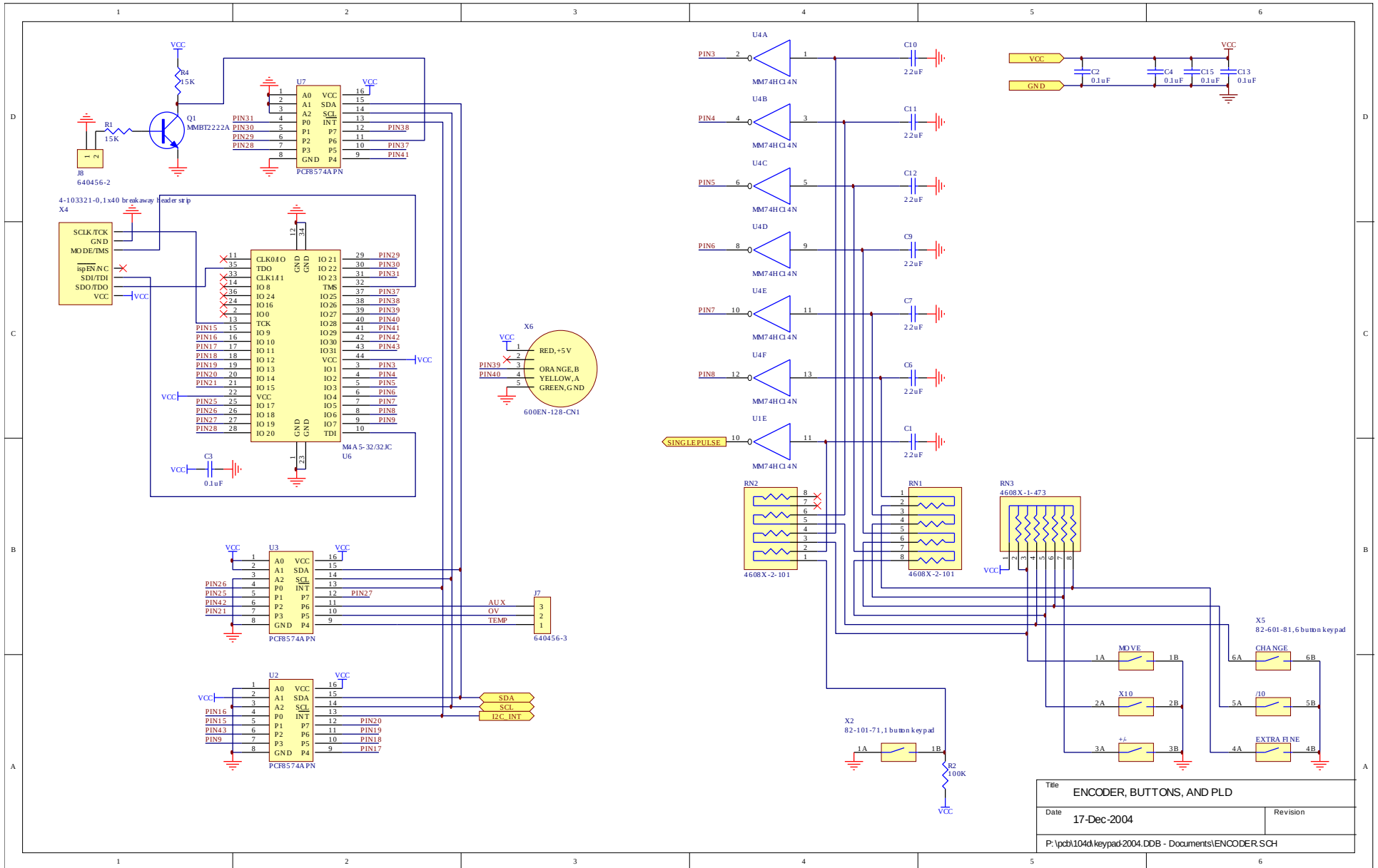

Title		ENCODER, BUTTONS, AND PLD
Date	17-Dec-2004	Revision
P:\pcb\104d\keypad\2004.DDB - Documents\ENCODER-SCH		

PCB 104D - KEYPAD / DISPLAY BOARD, 3/3

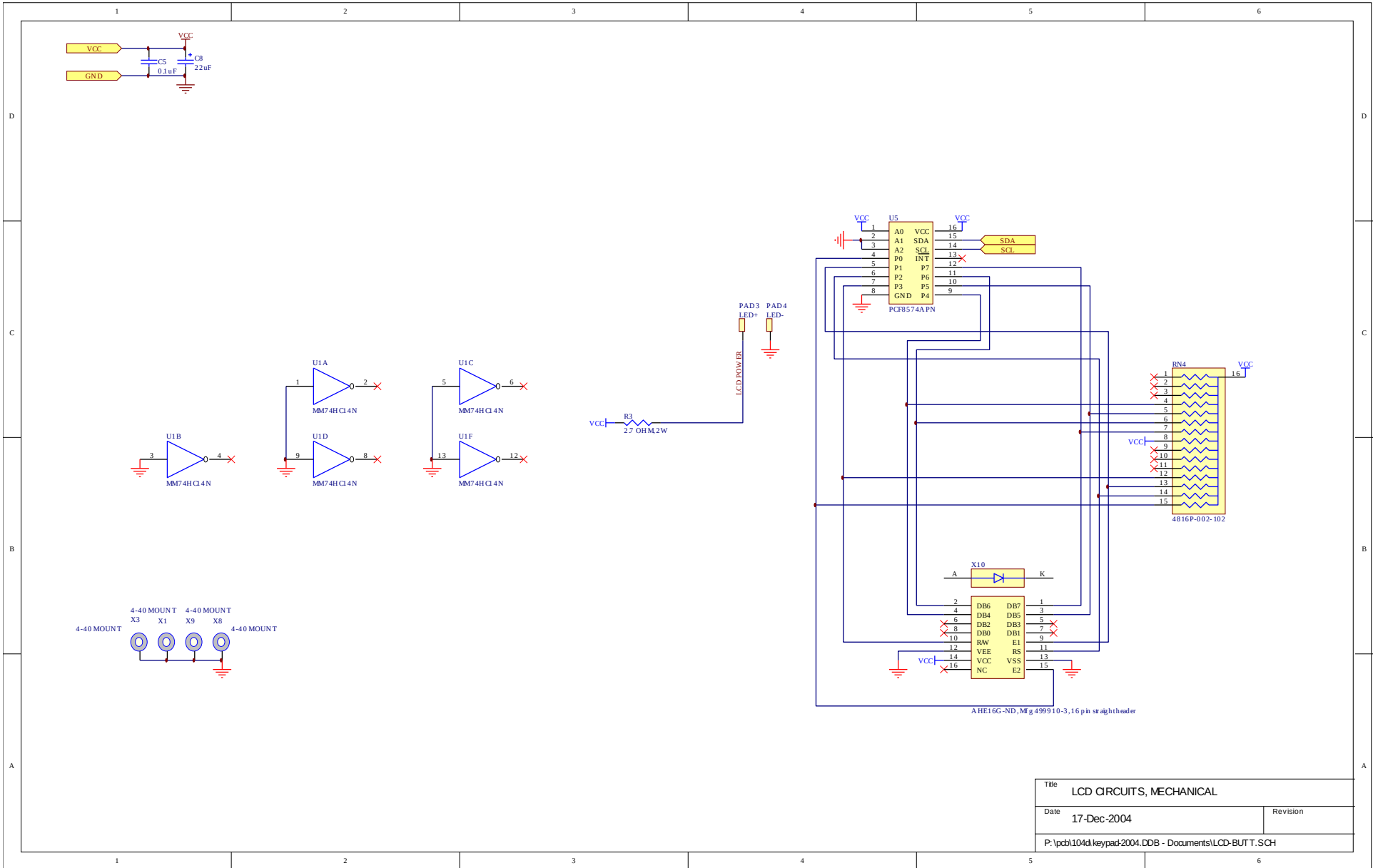

Title		LCD CIRCUITS, MECHANICAL	
Date	17-Dec-2004	Revision	
P:\pcb\104d\keypad2004.DDB - Documents\LCD-BUTT.SCH			

PERFORMANCE CHECK SHEET