



AVTECH ELECTROSYSTEMS LTD.

NANOSECOND WAVEFORM ELECTRONICS  
SINCE 1975

info@avtechpulse.com  
<http://www.avtechpulse.com/>

Tel: 888-670-8729 (USA & Canada)  
or +1-613-686-6675 (Worldwide)

BOX 5120, LCD MERIVALE  
OTTAWA, CANADA K2C3H5

## INSTRUCTIONS

MODEL AV-1041-B

±20 VOLT, 100 kHz

GENERAL-PURPOSE

LAB PULSE GENERATOR

WITH IEEE 488.2 / RS-232 / ETHERNET CONTROL

SERIAL NUMBER: 14407

### WARRANTY

Avtech Electrosystems Ltd. warrants products of its manufacture to be free from defects in material and workmanship under conditions of normal use. If, within one year after delivery to the original owner, and after prepaid return by the original owner, this Avtech product is found to be defective, Avtech shall at its option repair or replace said defective item. This warranty does not apply to units which have been disassembled, modified or subjected to conditions exceeding the applicable specifications or ratings. This warranty is the extent of the obligation assumed by Avtech with respect to this product and no other warranty or guarantee is either expressed or implied.

### TECHNICAL SUPPORT

Phone: 888-670-8729 (USA & Canada)  
or +1-613-686-6675 (Worldwide)

E-mail: [info@avtechpulse.com](mailto:info@avtechpulse.com)  
World Wide Web: <http://www.avtechpulse.com>

## TABLE OF CONTENTS

<b>WARRANTY.....</b>	<b>2</b>
<b>TECHNICAL SUPPORT.....</b>	<b>2</b>
<b>TABLE OF CONTENTS.....</b>	<b>3</b>
<b>INTRODUCTION.....</b>	<b>5</b>
<b>SPECIFICATIONS.....</b>	<b>6</b>
<b>REGULATORY NOTES.....</b>	<b>7</b>
FCC PART 18.....	7
EC DECLARATION OF CONFORMITY.....	7
DIRECTIVE 2011/65/EU (RoHS).....	8
DIRECTIVE 2002/96/EC (WEEE).....	8
FIRMWARE LICENSING.....	9
<b>INSTALLATION.....</b>	<b>10</b>
VISUAL CHECK.....	10
POWER RATINGS.....	10
CONNECTION TO THE POWER SUPPLY.....	10
PROTECTION FROM ELECTRIC SHOCK.....	11
ENVIRONMENTAL CONDITIONS.....	12
LABVIEW DRIVERS.....	12
<b>FUSES.....</b>	<b>13</b>
AC FUSE REPLACEMENT.....	13
DC FUSE REPLACEMENT.....	14
FUSE RATINGS.....	14
<b>FRONT PANEL CONTROLS.....</b>	<b>15</b>
<b>REAR PANEL CONTROLS.....</b>	<b>17</b>
<b>GENERAL INFORMATION.....</b>	<b>19</b>
BASIC PULSE CONTROL.....	19
TRIGGER MODES.....	22
PULSE WIDTH MODES.....	23
GATING MODES.....	23
<b>OPERATIONAL CHECK.....</b>	<b>24</b>
<b>PROGRAMMING YOUR PULSE GENERATOR.....</b>	<b>28</b>
KEY PROGRAMMING COMMANDS.....	28
ALL PROGRAMMING COMMANDS.....	29

<b>MECHANICAL INFORMATION.....</b>	<b>31</b>
TOP COVER REMOVAL.....	31
RACK MOUNTING.....	31
ELECTROMAGNETIC INTERFERENCE.....	31
<b>MAINTENANCE.....</b>	<b>32</b>
REGULAR MAINTENANCE.....	32
CLEANING.....	32
<b>WIRING DIAGRAMS.....</b>	<b>33</b>
WIRING OF AC POWER.....	33
PCB 158R5 - LOW VOLTAGE POWER SUPPLY.....	34
PCB 104H - KEYPAD / DISPLAY BOARD.....	35
PCB 100B - PULSE GENERATOR, 1 / 4.....	36
PCB 100B - PULSE GENERATOR, 2 / 4.....	37
PCB 100B - PULSE GENERATOR, 3 / 4.....	38
PCB 100B - PULSE GENERATOR, 4 / 4.....	39
MAIN WIRING.....	40
<b>PERFORMANCE CHECK SHEET.....</b>	<b>41</b>

Manual Reference: /files/server1/officefiles/instructword/av-1040/AV-1041-B,ed1.odt.

Last modified February 29, 2024.

Copyright © 2024 Avtech Electrosystems Ltd, All Rights Reserved.

## INTRODUCTION

The AV-1041-B is a high performance, GPIB and RS232-equipped instrument capable of generating  $\pm 20\text{V}$  into  $50\Omega$  loads at repetition rates up to 100 kHz. The pulse width is variable from 200 ns to 500 ms. The delay between the SYNC output and the main output can be varied from 0 to  $\pm 0.5$  seconds. Rise and fall times are fixed at less than 100 ns. Two logic-level outputs (normal and complemented) are also provided. These may be set to operate at TTL or ECL logic levels.

The AV-1041-B is a highly flexible instrument. Aside from the internal trigger source, it can also be triggered or gated by external TTL-level signals. A front-panel pushbutton or a computer command can also be used to trigger the instrument. In the external trigger mode, the output pulse width can be set by the pulse generator, or it can be set to follow the input trigger's pulse width. The AV-1041-B can generate single or double pulse outputs.

The source resistance can be set at either 2 or  $50\Omega$ . In the  $2\Omega$  setting, the maximum voltage available from the main output is  $\pm 20\text{V}$ . The pulse amplitude can be varied between 0 and  $\pm 20\text{V}$ , as can the DC offset voltage. In the  $50\Omega$  setting the maximum voltage available (into a  $50\Omega$  load) is  $\pm 10\text{V}$ . The  $50\Omega$  setting is useful for transmission line backmatching.

The AV-1041-B features front panel keyboard and adjust knob control of the output pulse parameters along with a four line by 40 character back-lit LCD display of the output amplitude, polarity, pulse width, pulse repetition frequency, source resistance and delay. The instrument includes memory to store up to four complete instrument setups. The operator may use the front panel or the computer interface to store a complete "snapshot" of all key instrument settings, and recall this setup at a later time.

This instrument is intended for use in research and development laboratories.

## SPECIFICATIONS

Model:	AV-1041-B
Outputs:	One main output, One logic output, One logic-complement output
Logic output levels:	May be set to operate at TTL or ECL levels. This setting applies to both the logic and logic-complement outputs.
Amplitude and peak output (to 50 Ohms) <sup>1</sup> :	Main output (when $Z_{OUT}=2\Omega$ ): $< \pm 1$ to $\pm 20$ V Main output (when $Z_{OUT}=50\Omega$ ): $< \pm 0.5$ to $\pm 10$ V Logic outputs (nominally): TTL: 0 and +5V, ECL: -0.8V and -1.6V.
Pulse repetition frequency (PRF):	1 Hz to 100 kHz
Pulse width (FWHM):	200 ns to 0.5 sec, or DC (subject to duty cycle limits)
Rise and fall times (20%-80%):	Main: $\leq 100$ ns, TTL: $\leq 5$ ns, ECL: $\leq 2$ ns
Adjustable DC offset <sup>1</sup> :	0 to $\pm 20$ V for $Z_{OUT}=2\Omega$ , 0 to $\pm 10$ V for $Z_{OUT}=50\Omega$
Parasitic DC offset:	$< \pm 200$ mV
Source impedance $Z_{OUT}$ :	Main output: $2\Omega$ or $50\Omega$ , switchable. This is the impedance in series with the output internally (not the load impedance).
Required load impedance:	$\geq 50\Omega$
Duty cycle (maximum):	70% (100% in PW DC mode). Additionally, there must be at least 100 ns between the trailing edge of one pulse and the leading edge of the next pulse. This "dead-time" requirement will reduce the maximum duty cycle at high PRFs.
Waveform aberrations:	Overshoot and ringing are less than $\leq 15\%$ at amplitudes of 1 V and higher with outputs terminating in $50\Omega$ .
Propagation delay:	$< 200$ ns (Ext trig in to pulse out, with delay set to zero)
Trigger modes:	Internal trigger, external trigger (TTL level pulse, $> 10$ ns, 1 k $\Omega$ input impedance), front-panel "Single Pulse" pushbutton, or single pulse trigger via computer command.
Trigger required (Gate in):	TTL, synchronous or asynchronous, active high or low
Delay jitter:	$\leq \pm 35$ ps $\pm 0.015\%$ RMS (sync out to pulse out)
Delay:	0 to $\pm 1$ sec (sync out to pulse out)
Sync output:	$> +3$ Volts, $> 50$ ns, will drive 50 Ohm loads
Double pulse mode spacing:	1 us to 1 second (measured between the two leading edges of the pulse doublet). Must not exceed one-half of the period. There must be at least (PW + 100 ns) of "dead time" (no pulsing) between the trailing edge of the first pulse and the leading edge of the second pulse. For instance, if the pulse width is 1 us, the programmed delay between leading edges must be greater than 1 us (the pulse width) + 1.1 us (the minimum dead time) = 2.1 us, and the period must be greater than 4.2 us.
Signal connectors:	BNC. Main outputs and Sync are on the front panel. Logic outputs & Gate & Trig inputs are on the rear.
GPIB and RS-232 control:	Included. See <a href="http://www.avtechpulse.com/gpib">http://www.avtechpulse.com/gpib</a> for details.
LabView Drivers:	Check <a href="http://www.avtechpulse.com/labview">http://www.avtechpulse.com/labview</a> for availability and downloads
Ethernet port, for remote control using VXI-11.3, ssh, telnet, & web:	Included. Recommended as a modern alternative to GPIB / RS-232. See <a href="http://www.avtechpulse.com/options/vxi">http://www.avtechpulse.com/options/vxi</a> for details.
Settings resolution:	The resolution of the timing parameters (pulse width, delay, period) varies, but is always better than 0.15% of ( set value  + 20 ns). The amplitude resolution is $< 0.1\%$ of the maximum amplitude.
Settings accuracy:	Typically $\pm 3\%$ (plus $\pm 0.1$ V or $\pm 2$ ns) after 10 minute warmup. For high-accuracy applications requiring traceable calibration, verify the output parameters with a calibrated oscilloscope.
Power requirement:	100 - 240 Volts, 50 - 60 Hz
Dimensions, Weight, Chassis:	100 x 430 x 375 mm (3.9" x 17" x 14.8"), 10 kg (22 lbs), anodized aluminum with blue-gray plastic trim
Temperature range:	$+5^{\circ}\text{C}$ to $+40^{\circ}\text{C}$

1) Peak output = amplitude + offset. The amplitude and offset can not be set to maximum at the same time, or the peak output rating will be exceeded.

## REGULATORY NOTES

### FCC PART 18

This device complies with part 18 of the FCC rules for non-consumer industrial, scientific and medical (ISM) equipment.

This instrument is enclosed in a rugged metal chassis and uses a filtered power entry module (where applicable). The main output signal is provided on a shielded connector that is intended to be used with shielded coaxial cabling and a shielded load. Under these conditions, the interference potential of this instrument is low.

If interference is observed, check that appropriate well-shielded cabling is used on the output connectors. Contact Avtech ([info@avtechpulse.com](mailto:info@avtechpulse.com)) for advice if you are unsure of the most appropriate cabling. Also, check that your load is adequately shielded. It may be necessary to enclose the load in a metal enclosure.

If any of the connectors on the instrument are unused, they should be covered with shielded metal “dust caps” to reduce the interference potential.

This instrument does not normally require regular maintenance to minimize interference potential. However, if loose hardware or connectors are noted, they should be tightened. Contact Avtech ([info@avtechpulse.com](mailto:info@avtechpulse.com)) if you require assistance.

### EC DECLARATION OF CONFORMITY



We                    Avtech Electrosystems Ltd.  
                          P.O. Box 5120, LCD Merivale  
                          Ottawa, Ontario  
                          Canada K2C 3H5

declare that this pulse generator meets the intent of Directive 2014/30/EU for Electromagnetic Compatibility. Compliance pertains to the following specifications as listed in the official Journal of the European Communities:

EN 50081-1 Emission

EN 50082-1 Immunity

and that this pulse generator meets the intent of the Low Voltage Directive 2014/35/EU. Compliance pertains to the following specifications as listed in the official Journal of the European Communities:

EN 61010-1:2010+A1:2019, Safety requirements for electrical equipment for measurement, control, and laboratory use

DIRECTIVE 2011/65/EU (RoHS)

We Avtech Electrosystems Ltd.  
P.O. Box 5120, LCD Merivale  
Ottawa, Ontario  
Canada K2C 3H5

declare that, to the best of our knowledge, all electrical and electronic equipment (EEE) sold by the company are in compliance with Directive 2011/65/EU of the European Parliament and of the Council of 8 June 2011 on the restriction of the use of certain hazardous substances in electrical and electronic equipment (also known as “RoHS Recast”). In addition, this declaration of conformity is issued under the sole responsibility of Avtech Electrosystems Ltd. Specifically, products manufactured do not contain the substances listed in the table below in concentrations greater than the listed maximum value.

<i>Material/Substance</i>	<i>Threshold level</i>
Lead (Pb)	< 1000 ppm (0.1% by mass)
Mercury (Hg)	< 1000 ppm (0.1% by mass)
Hexavalent Chromium (Cr6+)	< 1000 ppm (0.1% by mass)
Polybrominated Biphenyls (PBB)	< 1000 ppm (0.1% by mass)
Polybrominated Diphenyl ethers (PBDE)	< 1000 ppm (0.1% by mass)
Cadmium (Cd)	< 100 ppm (0.01% by mass)
Bis(2-ethylhexyl) phthalate (DEHP)	< 1000 ppm (0.1% by mass)
Butyl benzyl phthalate (BBP)	< 1000 ppm (0.1% by mass)
Dibutyl phthalate (DBP)	< 1000 ppm (0.1% by mass)
Diisobutyl phthalate (DIBP)	< 1000 ppm (0.1% by mass)

DIRECTIVE 2002/96/EC (WEEE)

European customers who have purchased this equipment directly from Avtech will have completed a “WEEE Responsibility Agreement” form, accepting responsibility for WEEE compliance (as mandated in Directive 2002/96/EC of the European Union and local



laws) on behalf of the customer, as provided for under Article 9 of Directive 2002/96/EC.

Customers who have purchased Avtech equipment through local representatives should consult with the representative to determine who has responsibility for WEEE compliance. Normally, such responsibilities will lie with the representative, unless other arrangements (under Article 9) have been made.

Requirements for WEEE compliance may include registration of products with local governments, reporting of recycling activities to local governments, and financing of recycling activities.

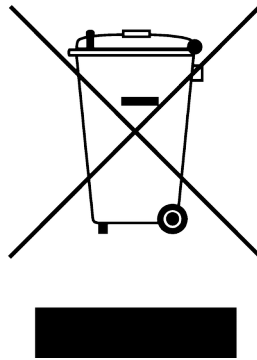

### FIRMWARE LICENSING

Instruments with firmware versions 5.00 or higher use open-source software internally. Some of this software requires that the source code be made available to the user as a condition of its licensing. This source code is available upon request (contact [info@avtechpulse.com](mailto:info@avtechpulse.com)).

Earlier firmware versions do not contain any open source software.

## INSTALLATION

### VISUAL CHECK

After unpacking the instrument, examine to ensure that it has not been damaged in shipment. Visually inspect all connectors, knobs, liquid crystal displays (LCDs), and the handles. Confirm that a power cord, a GPIB cable, and two instrumentation manuals (this manual and the “Programming Manual for -B Instruments”) are with the instrument. If the instrument has been damaged, file a claim immediately with the company that transported the instrument.

### POWER RATINGS

This instrument is intended to operate from 100 - 240 V, 50 - 60 Hz.

The maximum power consumption is 90 Watts. Please see the “FUSES” section for information about the appropriate AC and DC fuses.

This instrument is an “Installation Category II” instrument, intended for operation from a normal single-phase supply.

### CONNECTION TO THE POWER SUPPLY

An IEC-320 three-pronged recessed male socket is provided on the back panel for AC power connection to the instrument. One end of the detachable power cord that is supplied with the instrument plugs into this socket. The other end of the detachable power cord plugs into the local mains supply. Use only the cable supplied with the instrument. The mains supply must be earthed, and the cord used to connect the instrument to the mains supply must provide an earth connection. (The supplied cord does this.)

 Warning: Failure to use a grounded outlet may result in injury or death due to electric shock. This product uses a power cord with a ground connection. It must be connected to a properly grounded outlet. The instrument chassis is connected to the ground wire in the power cord.

The table below describes the power cord that is normally supplied with this instrument, depending on the destination region:

Destination Region	Description	Option	Manufacturer	Part Number
United Kingdom, Hong Kong, Singapore, Malaysia	BS 1363, 230V, 50 Hz	-AC00	Qualtek	370001-E01
Australia, New Zealand	AS 3112:2000, 230-240V, 50 Hz	-AC01	Qualtek	374003-A01
Continental Europe, Korea, Indonesia, Russia	European CEE 7/7 "Schuko" 230V, 50 Hz	-AC02	Qualtek	364002-D01
North America, Taiwan	NEMA 5-15, 120V, 60 Hz	-AC03	Qualtek	312007-01
Switzerland	SEV 1011, 230V, 50 Hz	-AC06	Qualtek	378001-E01
South Africa, India	SABS 164-1, 220-250V, 50 Hz	-AC17	Volex	2131H 10 C3
Japan	JIS 8303, 100V, 50-60 Hz	-AC18	Qualtek	397002-01
Israel	SI 32, 220V, 50 Hz	-AC19	Qualtek	398001-01
China	GB 1002-1 / 2099-1, 220V, 50 Hz	-AC22	Qualtek	399012-01

## PROTECTION FROM ELECTRIC SHOCK

 Operators of this instrument must be protected from electric shock at all times. The owner must ensure that operators are prevented access and/or are insulated from every connection point. In some cases, connections must be exposed to potential human contact. Operators must be trained to protect themselves from the risk of electric shock. This instrument is intended for use by qualified personnel who recognize shock hazards and are familiar with safety precautions required to avoid possibly injury. In particular, operators should:

1. Keep exposed high-voltage wiring to an absolute minimum.
2. Wherever possible, use shielded connectors and cabling.
3. Connect and disconnect loads and cables only when the instrument is turned off.
4. Keep in mind that all cables, connectors, oscilloscope probes, and loads must have an appropriate voltage rating.
5. Do not attempt any repairs on the instrument, beyond the fuse replacement procedures described in this manual. Contact Avtech technical support (see page 2 for contact information) if the instrument requires servicing. Service is to be performed solely by qualified service personnel.

## ENVIRONMENTAL CONDITIONS

This instrument is intended for use under the following conditions:

1. indoor use;
2. altitude up to 2 000 m;
3. temperature 5 °C to 40 °C;
4. maximum relative humidity 80 % for temperatures up to 31 °C decreasing linearly to 50 % relative humidity at 40 °C;
5. Mains supply voltage fluctuations up to  $\pm 10$  % of the nominal voltage;
6. no pollution or only dry, non-conductive pollution.

## LABVIEW DRIVERS

A LabVIEW driver for this instrument is available for download on the Avtech web site, at <http://www.avtechpulse.com/labview>. A copy is also available in National Instruments' Instrument Driver Library at <http://www.natinst.com/>.

## FUSES

This instrument contains four fuses. All are accessible from the rear-panel. Two protect the AC prime power input, and two protect the internal DC power supplies. The locations of the fuses on the rear panel are shown in the figure below:

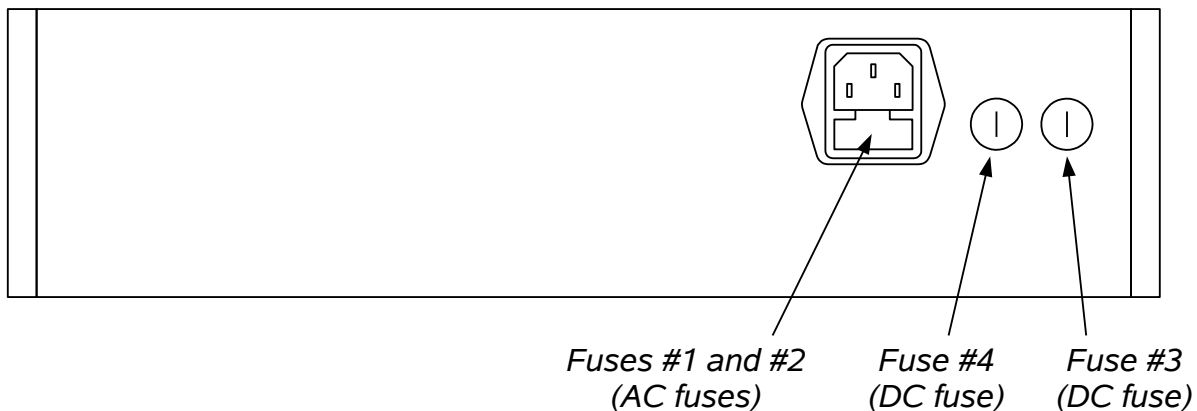

### AC FUSE REPLACEMENT

To physically access the AC fuses, the power cord must be detached from the rear panel of the instrument. The fuse drawer may then be extracted using a small flat-head screwdriver, as shown below:

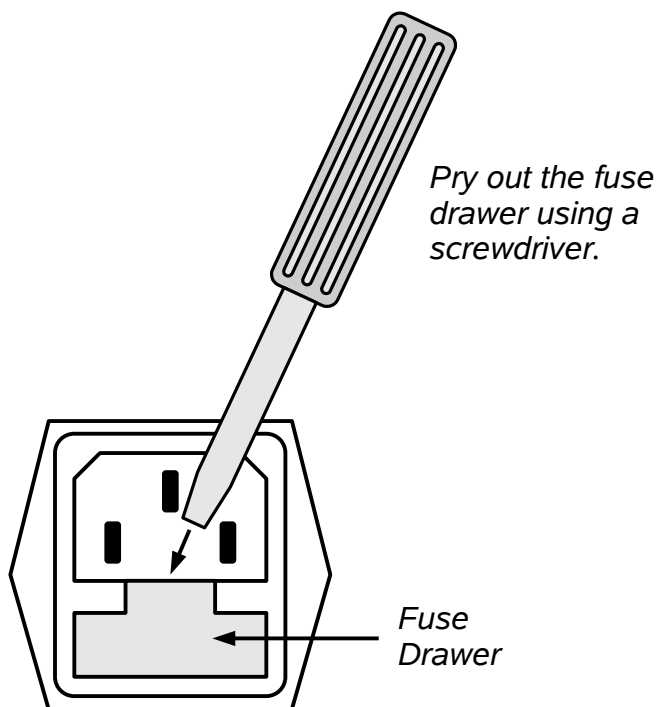

## DC FUSE REPLACEMENT

The DC fuses may be replaced by inserting the tip of a flat-head screwdriver into the fuse holder slot, and rotating the slot counter-clockwise. The fuse and its carrier will then pop out.

## FUSE RATINGS

The following table lists the required fuses for standard models:

Fuses	Nominal Mains Voltage	Rating	Case Size	Recommended Replacement Part	
				Littelfuse Part Number	Digi-Key Stock Number
#1, #2 (AC)	115 V	0.8A, 250V, Time-Delay	5×20 mm	0218.800HXP	F2418-ND
	230 V	0.5A, 250V, Time-Delay	5×20 mm	0218.500HXP	F2416-ND
#3 (DC)	N/A	1.0A, 250V, Time-Delay	5×20 mm	0218001.HXP	F2419-ND
#4 (DC)	N/A	1.0A, 250V, Time-Delay	5×20 mm	0218001.HXP	F2419-ND

Certain combinations of features may require slightly different fuse ratings. The required fuse ratings will be clearly marked on the rear panel of the instrument.

The recommended fuse manufacturer is Littelfuse (<http://www.littelfuse.com>).

Replacement fuses may be easily obtained from Digi-Key (<http://www.digikey.com>) and other distributors.

## FRONT PANEL CONTROLS

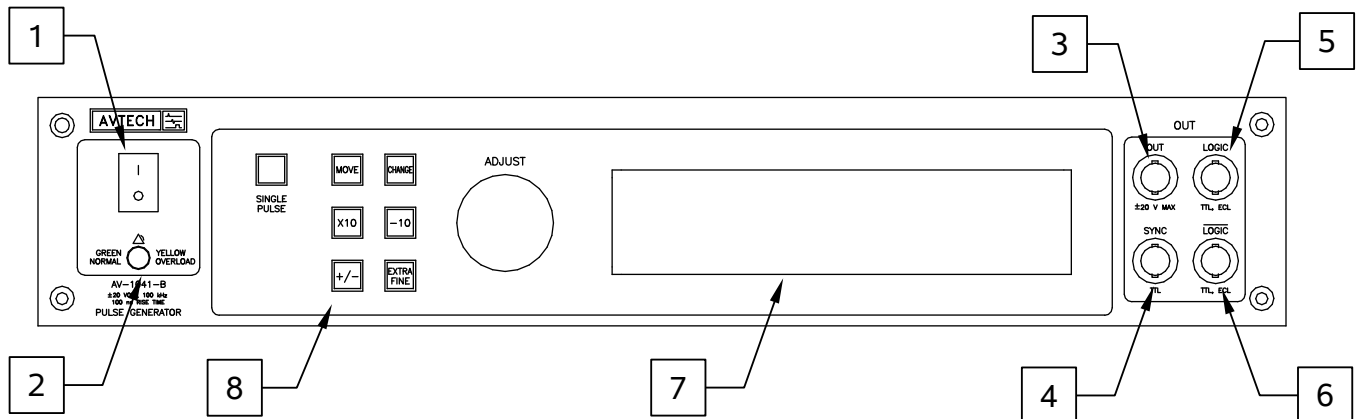

1. **POWER Switch**. This is the main power switch. When turning the instrument on, there is normally a delay of 10 seconds before anything is shown on the main display, as the internal operating system boots up.
2. **OVERLOAD Indicator**. When the instrument is powered, this indicator is normally green, indicating normal operation. If this indicator is yellow, an internal automatic overload protection circuit has been tripped. If the unit is overloaded (by operating at an exceedingly high duty cycle or by operating into a very low impedance), the protective circuit will disable the output of the instrument and turn the indicator light yellow. The light will stay yellow (i.e. output disabled) for about 5 seconds after which the instrument will attempt to re-enable the output (i.e. light green) for about 1 second. If the overload condition persists, the output will be disabled again (i.e. light yellow) for another 5 seconds. If the overload condition has been removed, the instrument will resume normal operation.

This overload indicator may flash yellow briefly at start-up. This is not a cause for concern.

3. **OUT CONNECTOR**. This BNC connector provides the main output signal, into load impedances of  $50\Omega$  or higher. It can generate voltages of up to  $\pm 10V$ .
4. **SYNC OUT**. This connector supplies a SYNC output that can be used to trigger other equipment, particularly oscilloscopes. This signal leads (or lags) the main output by a duration set by the "DELAY" controls and has an approximate amplitude of +3 Volts to  $R_L > 1k\Omega$  with a pulse width of approximately 50 ns.
5. **LOGIC Output**. The signal on this output has approximately the timing parameters as the main output (i.e. frequency, pulse width, and delay) but the amplitude is fixed at either TTL logic levels (0 and +5V, approximately) or ECL logic levels (-1.6V and -0.8V, approximately), depending on the settings. When using this output, it is recommended that it be terminated with a  $50\Omega$  load.

6. LOGIC-Complement Output. The signal on this output is the logical complement of the signal on the LOGIC output (item 4). That is, the high and low logic levels are reversed.
7. LIQUID CRYSTAL DISPLAY (LCD). This LCD is used in conjunction with the keypad to change the instrument settings. Normally, the main menu is displayed, which lists the key adjustable parameters and their current values. The "Programming Manual for -B Instruments" describes the menus and submenus in detail.
8. KEYPAD.

Control Name	Function
MOVE	This moves the arrow pointer on the display.
CHANGE	This is used to enter the submenu, or to select the operating mode, pointed to by the arrow pointer.
×10	If one of the adjustable numeric parameters is displayed, this increases the setting by a factor of ten.
÷10	If one of the adjustable numeric parameters is displayed, this decreases the setting by a factor of ten.
+/-	If one of the adjustable numeric parameters is displayed, and this parameter can be both positive or negative, this changes the sign of the parameter.
EXTRA FINE	This changes the step size of the ADJUST knob. In the extra-fine mode, the step size is twenty times finer than in the normal mode. This button switches between the two step sizes.
ADJUST	This large knob adjusts the value of any displayed numeric adjustable values, such as frequency, pulse width, etc. The adjust step size is set by the "EXTRA FINE" button.  When the main menu is displayed, this knob can be used to move the arrow pointer.



## REAR PANEL CONTROLS

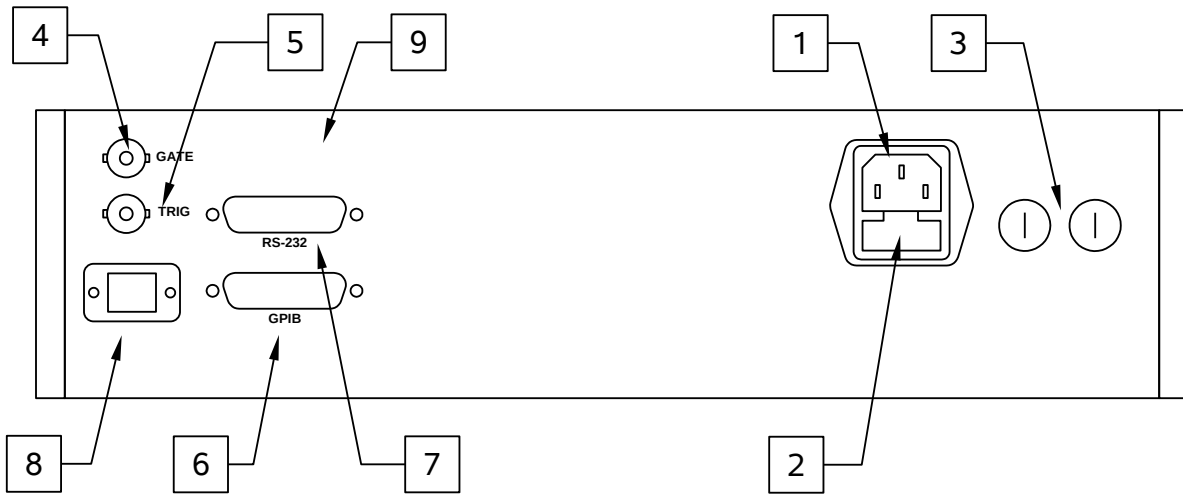

*Note: some connectors may be in different positions than shown above, depending on the exact combination of options ordered.*

1. AC POWER INPUT. An IEC-320 C14 three-pronged recessed male socket is provided on the back panel for AC power connection to the instrument. One end of the detachable power cord that is supplied with the instrument plugs into this socket.
2. AC FUSE DRAWER. The two fuses that protect the AC input are located in this drawer. Please see the “FUSES” section of this manual for more information.
3. DC FUSES. These two fuses protect the internal DC power supplies. Please see the “FUSES” sections of this manual for more information.
4. GATE. This TTL-level (0 and +5V) logic input can be used to gate the triggering of the instrument. This input can be either active high or active low, depending on the front panel settings or programming commands. (The instrument triggers normally when this input is unconnected). When set to active high mode, this input is pulled-down to ground by a 1 k $\Omega$  resistor. When set to active low mode, this input is pulled-up to +5V by a 1 k $\Omega$  resistor.
5. TRIG. This TTL-level (0 and +5V) logic input can be used to trigger the instrument, if the instrument is set to triggering externally. The instrument triggers on the rising edge of this input. The input impedance of this input is 1 k $\Omega$ . (Depending on the length of cable attached to this input, and the source driving it, it may be desirable to add a coaxial 50 Ohm terminator to this input to provide a proper transmission line termination. The Pomona Electronics 4119-50 BNC feed-thru 50 Ohm terminator is suggested for this purpose.)

When triggering externally, the instrument can be set such that the output pulse width tracks the pulse width on this input, or the output pulse width can be set independently.

6. GPIB Connector. A standard GPIB cable can be attached to this connector to allow the instrument to be computer-controlled. See the “Programming Manual for -B Instruments” for more details on GPIB control.
7. RS-232 Connector. A standard serial cable with a 25-pin male connector can be attached to this connector to allow the instrument to be computer-controlled. A user name (“admin”) and a password (“default”, as shipped from the factory) are required when logging into a serial terminal session. The internal controller attempts to auto-sense the parity setting. It may be necessary to send a few return characters before attempting a login in order to provide enough data to allow this auto-sensing to work. (A standard Linux “agetty” process is used to implement serial control internally.) See the “Programming Manual for -B Instruments” for more details on RS-232 control.
8. Network Connector. This Ethernet connector allows the instrument to be remotely controlled using the VXI-11.3, ssh (secure shell), telnet, and http (web) protocols. See the “Programming Manual for -B Instruments” for more details.

## GENERAL INFORMATION

### BASIC PULSE CONTROL

This instrument can be triggered by its own internal clock or by an external TTL trigger signal. In either case, four output channels respond to the trigger: OUT, SYNC, LOGIC, and LOGIC-Complement.

- OUT. This is the main output. The pulse width, amplitude, and offset are all adjustable. The maximum output voltage is  $\pm 20\text{V}$ . (This voltage is reduced by a factor of two if the output impedance is set at  $50\Omega$ , and a  $50\Omega$  load is used.)
- SYNC. The SYNC pulse is a fixed-width TTL-level reference pulse used to trigger oscilloscopes or other measurement systems. When the delay is set to a positive value the SYNC pulse precedes the OUT pulse. When the delay is set to a negative value the SYNC pulse follows the OUT pulse.
- LOGIC. The signal on this output has approximately the timing parameters as the main output (i.e. frequency, pulse width, and delay) but the amplitude is fixed at either TTL logic levels (0 and +5V, approximately) or ECL logic levels (-1.6V and -0.8V, approximately), depending on the settings. When using this output, it is recommended that it be terminated with a  $50\Omega$  load.
- LOGIC-Complement Output. The signal on this output is the logical complement of the signal on the LOGIC output. That is, the high and low logic levels are reversed.

These pulses are illustrated below, assuming internal triggering and a positive delay:

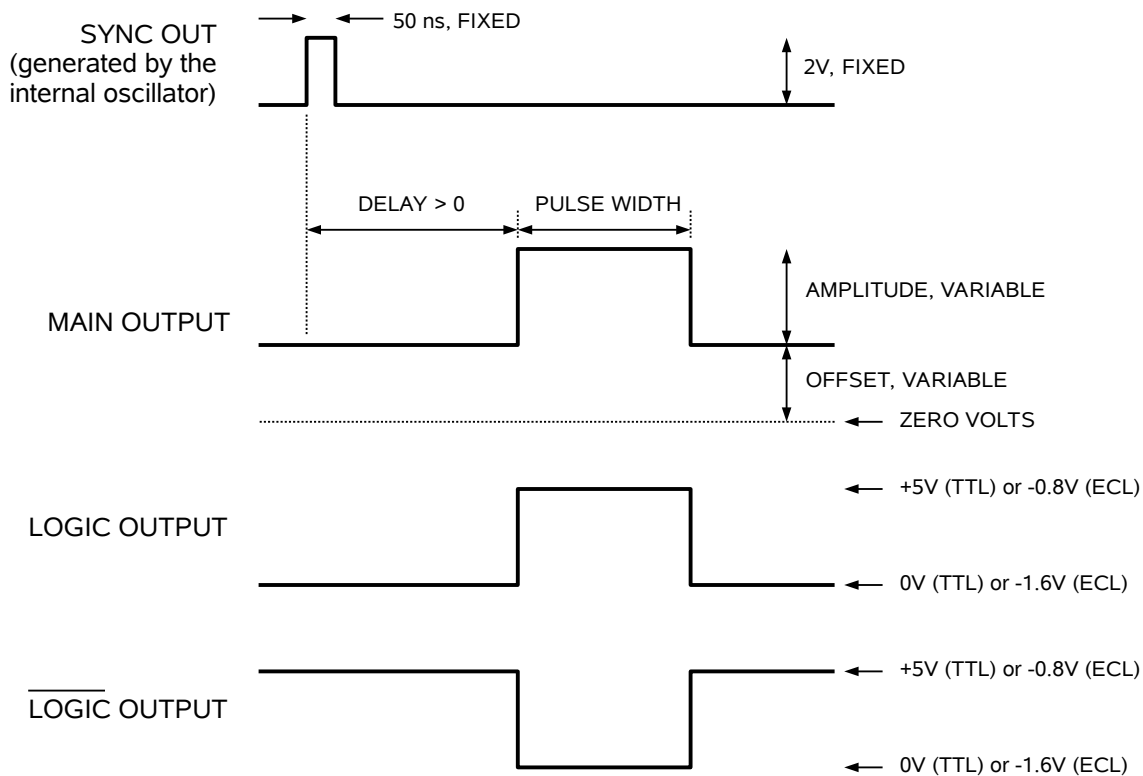

If the delay is negative, the order of the SYNC and OUT pulses is reversed:

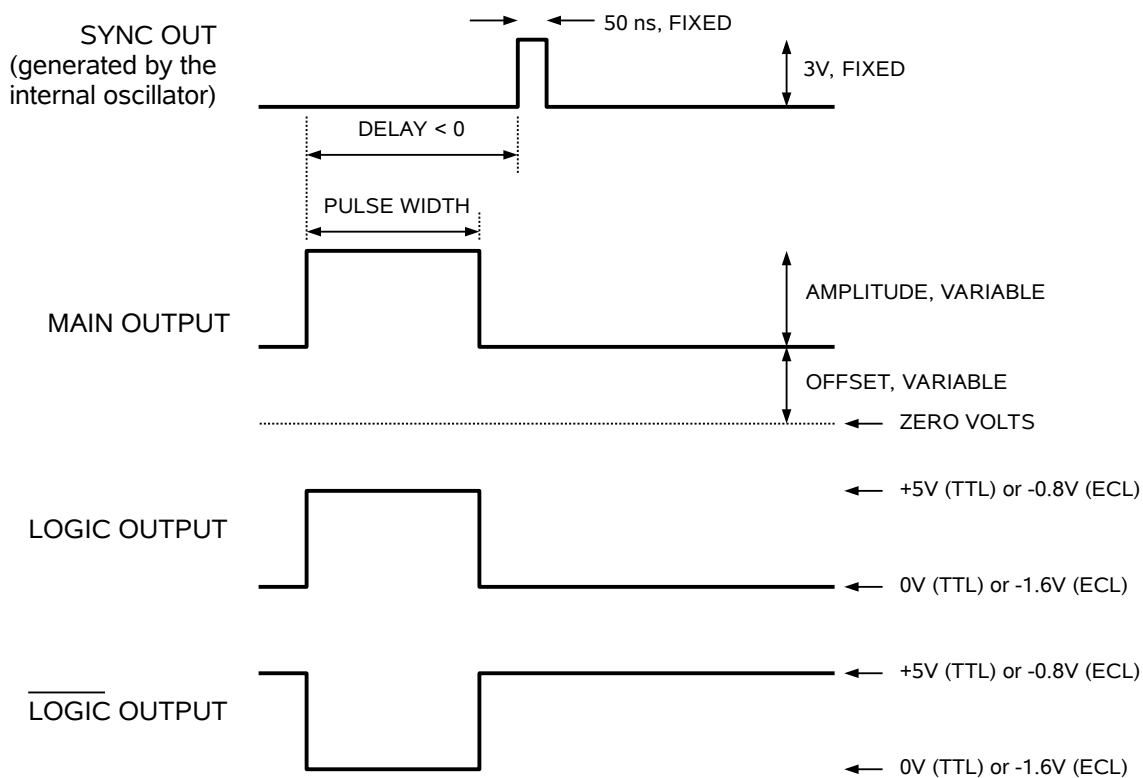

The next figure illustrates the relationship between the signals when an external TTL-level trigger is used:

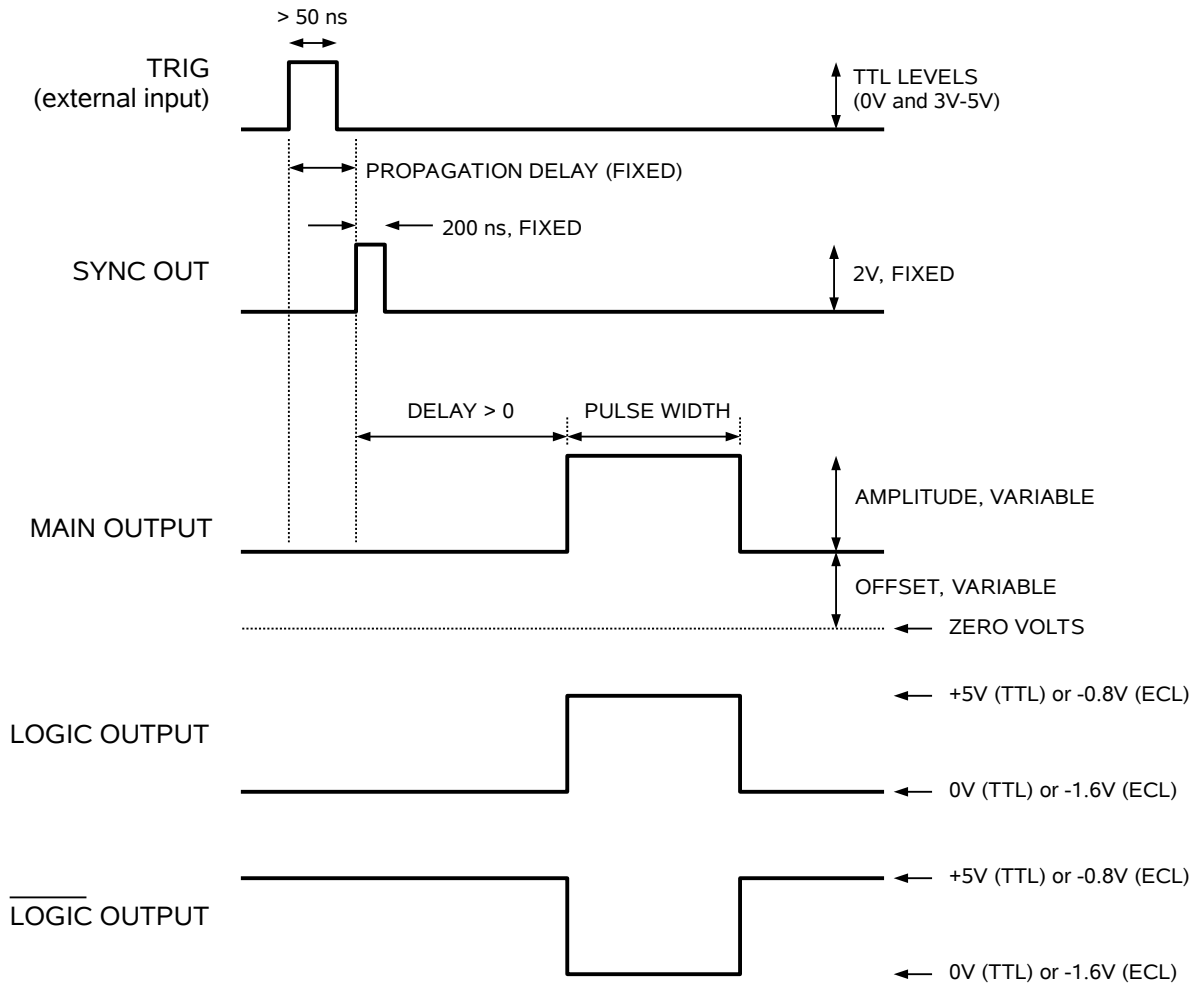

As before, if the delay is negative, the order of the SYNC and OUT pulses is reversed.

The last figure illustrates the relationship between the signal when an external TTL-level trigger is used in the  $PW_{IN}=PW_{OUT}$  mode. In this case, the output pulse width equals the external trigger's pulse width (approximately), and the delay circuit is bypassed:

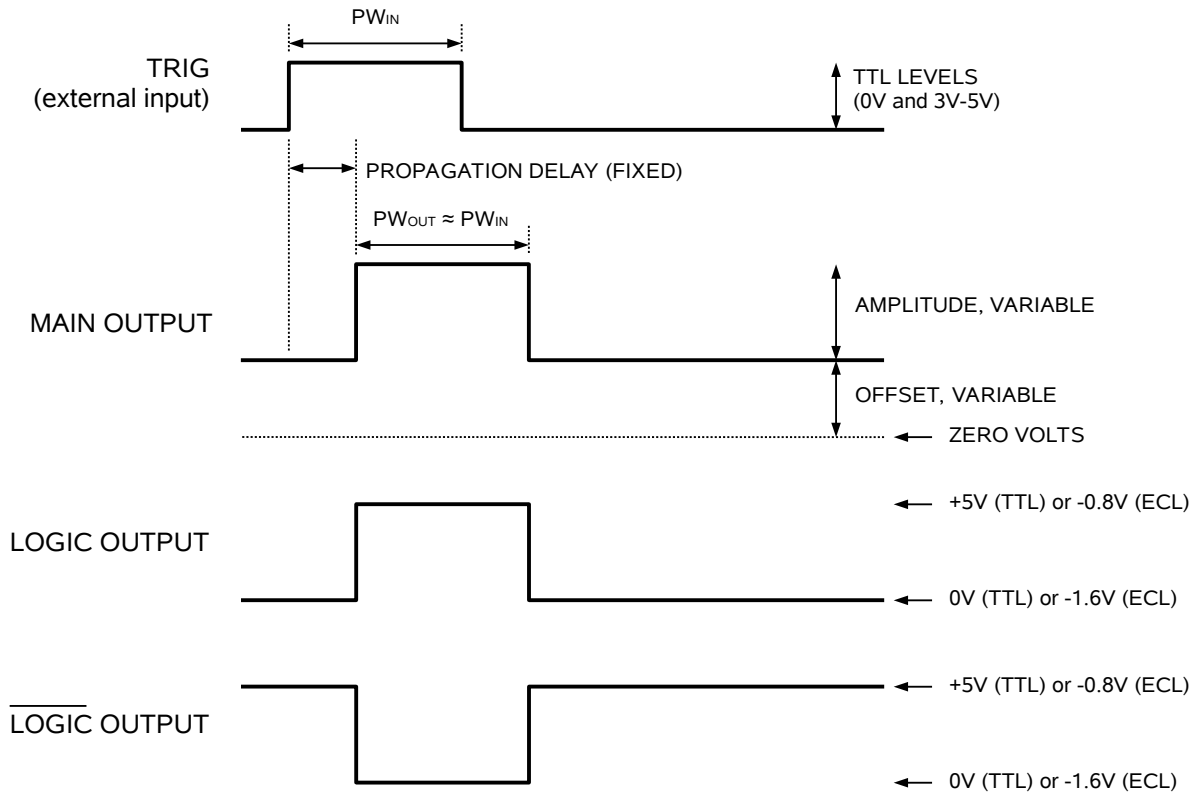

The delay, pulse width, and frequency (when in the internal mode), of the OUT pulse can be varied with front panel controls or via the GPIB or RS-232 computer interfaces.

## TRIGGER MODES

This instrument has four trigger modes:

- Internal Trigger: the instrument controls the trigger frequency, and generates the clock internally.
- External Trigger: the instrument is triggered by an external TTL-level clock on the back-panel TRIG connector.
- Manual Trigger: the instrument is triggered by the front-panel “SINGLE PULSE” pushbutton.
- Hold Trigger: the instrument is set to not trigger at all.

These modes can be selected using the front panel trigger menu, or by using the appropriate programming commands. (See the “Programming Manual for -B Instruments” for more details.)

## PULSE WIDTH MODES

This instrument has two pulse width modes:

- Normal: the instrument controls the output pulse width.
- $PW_{IN}=PW_{OUT}$ : the output pulse width equals the pulse width of the trigger signal on the “TRIG” connector. The instrument must be in the external trigger mode.

These modes can be selected using the front panel pulse width menu, or by using the appropriate programming commands. (See the “Programming Manual for -B Instruments” for more details.)

## GATING MODES

Triggering can be suppressed by a TTL-level signal on the rear-panel GATE connector. The instrument can be set to stop triggering when this input high or low, using the front-panel gate menu or the appropriate programming commands. This input can also be set to act synchronously or asynchronously. When set to asynchronous mode, the GATE will disable the output immediately. Output pulses may be truncated. When set to synchronous mode, the output will complete the full pulse width if the output is high, and then stop triggering. No pulses are truncated in this mode.

## OPERATIONAL CHECK

This section describes a sequence to confirm the basic operation of the instrument. It should be performed after receiving the instrument. It is a useful learning exercise as well.

Before proceeding with this procedure, finish reading this instruction manual thoroughly. Then read the “Local Control” section of the “Programming Manual for -B Instruments” thoroughly. The “Local Control” section describes the front panel controls used in this operational check - in particular, the MOVE, CHANGE, and ADJUST controls.

1. Connect a cable from the SYNC OUT connector to the TRIG input of an oscilloscope. Connect a 8W (or higher), low-inductance (not wirewound) 50 $\Omega$  load to the OUT connector and place the scope probe across this load. Set the oscilloscope to trigger externally with the vertical setting at 5 Volts/div and the horizontal setting at 2 us/div.
2. Turn on the AV-1041-B. The main menu will appear on the LCD.
3. To set the AV-1041-B to trigger from the internal clock at a PRF of 100 kHz:
  - a) The arrow pointer should be pointing at the frequency menu item. If it is not, press the MOVE button until it is.
  - b) Press the CHANGE button. The frequency submenu will appear. Rotate the ADJUST knob until the frequency is set at 100 kHz.
  - c) The arrow pointer should be pointing at the “Internal” choice. If it is not, press MOVE until it is.
  - d) Press CHANGE to return to the main menu.
4. To set the delay to 100 ns:
  - a) Press the MOVE button until the arrow pointer is pointing at the delay menu item.
  - b) Press the CHANGE button. The delay submenu will appear. Rotate the ADJUST knob until the delay is set at 100 ns.
  - c) The arrow pointer should be pointing at the “Normal” choice. If it is not, press MOVE until it is.
  - d) Press CHANGE to return to the main menu.



5. To set the pulse width to 1 us:
  - a) Press the MOVE button until the arrow pointer is pointing at the pulse width menu item.
  - b) Press the CHANGE button. The pulse width submenu will appear. Rotate the ADJUST knob until the pulse width is set at 1 us.
  - c) The arrow pointer should be pointing at the “Normal” choice. If it is not, press MOVE until it is.
  - d) Press CHANGE to return to the main menu.
6. The main menu display should show that the output impedance ( $Z_{OUT}$ ) is set at  $2\Omega$ . If it is different, change the settings.
7. At this point, nothing should appear on the oscilloscope.
8. To enable the output:
  - a) Press the MOVE button until the arrow pointer is pointing at the output menu item.
  - b) Press the CHANGE button. The output submenu will appear.
  - c) Press MOVE until the arrow pointer is pointing at the “ON” choice.
  - d) Press CHANGE to return to the main menu.
9. To change the output amplitude:
  - a) Press the MOVE button until the arrow pointer is pointing at the amplitude menu item.
  - b) Press the CHANGE button. The amplitude submenu will appear. Rotate the ADJUST knob until the amplitude is set at +20V.
  - c) Observe the oscilloscope. You should see 1 us wide, +20V pulses.
  - d) Rotate the ADJUST knob. The amplitude as seen on the oscilloscope should vary. Return it to +20V.
  - e) Press CHANGE to return to the main menu.
10. Try varying the pulse width, by repeating step (5). As you rotate the ADJUST knob, the pulse width on the oscilloscope will change. It should agree with the displayed value.

11. Go to the output impedance menu, and set the output impedance ( $Z_{OUT}$ ) to  $50\ \Omega$ . If a  $50\ \Omega$  load is attached to the output (see step 1) the amplitude should fall by a factor of 2, to 10V.
12. Set the output impedance ( $Z_{OUT}$ ) back to  $2\ \Omega$  and return to the main menu.
13. To change the output amplitude polarity:
  - a) Press the MOVE button until the arrow pointer is pointing at the amplitude menu item.
  - b) Press the CHANGE button. The amplitude submenu will appear.
  - c) Press the “+/-” button. The amplitude as seen on the oscilloscope should become negative.
  - d) Press CHANGE to return to the main menu.
14. To add a DC offset:
  - a) Press the MOVE button until the arrow pointer is pointing at the offset menu item.
  - b) Press the CHANGE button. The offset submenu will appear. Rotate the ADJUST knob until the offset is set at -5V.
  - c) Observe the oscilloscope. You should see 1 us wide pulses, swinging between -5V and +15V.
  - d) Press CHANGE to return to the main menu.
15. To set the logic outputs to TTL operation:
  - a) Press the MOVE button until the arrow pointer is pointing at the logic menu item.
  - b) The arrow pointer should be pointing at the “TTL level” choice. If it is not, press MOVE until it is.
  - c) Press CHANGE to return to the main menu.
16. Move the  $50\ \Omega$  load from the OUT connector to the LOGIC connector. Observe the waveform. You should see 150 ns wide pulses, swinging between 0 and +5V (approximately).
17. To set the logic outputs to ECL operation:

- a) Press the MOVE button until the arrow pointer is pointing at the logic menu item.
  - b) Press MOVE until the arrow pointer is pointing at the “ECL level” choice.
  - c) Press CHANGE to return to the main menu.
18. Observe the waveform. You should see 150 ns wide pulses, swinging between -1.6V and -0.8V (approximately).

This completes the operational check.

## PROGRAMMING YOUR PULSE GENERATOR

### KEY PROGRAMMING COMMANDS

The “Programming Manual for -B Instruments” describes in detail how to connect the pulse generator to your computer, and the programming commands themselves. A large number of commands are available; however, normally you will only need a few of these. Here is a basic sample sequence of commands that might be sent to the instrument after power-up:

*rst	(resets the instrument)
trigger:source internal	(selects internal triggering)
frequency 1000 Hz	(sets the frequency to 1000 Hz)
pulse:width 10 us	(sets the pulse width to 10 us)
pulse:delay 1 us	(sets the delay to 1 us)
output:impedance 2	(sets the output impedance to 2Ω. The only other allowed setting is output:impedance 50.)
output:type TTL	(sets the logic outputs to TTL mode)
volt:ampl 5	(sets the amplitude to 5 V)
volt:low -2	(sets the DC offset to -2 V)
output on	(turns on the output)

For triggering a single event, this sequence would be more appropriate:

*rst	(resets the instrument)
trigger:source hold	(turns off all triggering)
pulse:width 100 ns	(sets the pulse width to 100 ns)
output on	(turns on the output)
volt:ampl 5	(sets the amplitude to 5 V)
volt:low -2	(sets the DC offset to -2 V)
trigger:source immediate	(generates a single non-repetitive trigger event)
trigger:source hold	(turns off all triggering)
output off	(turns off the output)

To set the instrument to trigger from an external TTL signal applied to the rear-panel TRIG connector, use:

*rst	(resets the instrument)
trigger:source external	(selects external triggering)
pulse:width 10 us	(sets the pulse width to 10 us)
pulse:delay 1 us	(sets the delay to 1 us)
output:impedance 2	(sets the output impedance to 2Ω. The only other allowed setting is output:impedance 50.)
output:type TTL	(sets the logic outputs to TTL mode)
volt:ampl 5	(sets the amplitude to 5 V)

volt:low -2                                (sets the DC offset to -2 V)  
 output on                                    (turns on the output)

In the above example, the pulse width of the output was set by a programming command. To set the output pulse width to track the trigger pulse width in external mode, use:

\*rst    (resets the instrument)  
 trigger:source external                    (selects internal triggering)  
 pulse:width in                              (PW<sub>OUT</sub> = PW<sub>IN</sub>)  
 output:impedance 2                         (sets the output impedance to 2Ω. The only other allowed setting is output:impedance 50.)  
 output:type TTL                             (sets the logic outputs to TTL mode)  
 volt:ampl 5                                  (sets the amplitude to 5 V)  
 volt:low -2                                  (sets the DC offset to -2 V)  
 output on                                    (turns on the output)

These commands will satisfy 90% of your programming needs.

## ALL PROGRAMMING COMMANDS

For more advanced programmers, a complete list of the available commands is given below. These commands are described in detail in the “Programming Manual for -B Instruments”. (Note: this manual also includes some commands that are not implemented in this instrument. They can be ignored.)

<u>Keyword</u>	<u>Parameter</u>	<u>Notes</u>
DIAGnostic:		
:AMPLitude		
:CALibration	<numeric value>	[no query form]
:OFFSet		
:CALibration	<numeric value>	[no query form]
OUTPut:		
:[STATe]	<boolean value>	
:IMPedance	<numeric value>	
:PROTection		
:TRIPped?		[query only]
:TYPE	TTL   ECL	
[SOURce]:		
:FREQuency		
[:CW   FIXed]	<numeric value>	
[SOURce]:		
:PULSe		
:PERiod	<numeric value>	
:WIDTh	<numeric value>	
:DCYCLE	<numeric value>	
:HOLD	WIDTh   DCYCLE	
:DELay	<numeric value>	

:DOUBLE		
[:STATE]	<boolean value>	
:DELay	<numeric value>	
:GATE		
:TYPE	ASync   SYNC	
:LEVel	HIgh   LOw	
[SOURce]:		
:VOLTagE		
[:LEVel]		
[:IMMediate]		
[:AMPLitude]	<numeric value>	
:LOW	<numeric value>	
:PROTection		
:TRIPped?		[query only]
STATUS:		
:OPERation		
:[EVENT]?		[query only, always returns "0"]
:CONDition?		[query only, always returns "0"]
:ENABle	<numeric value>	[implemented but not useful]
:QUEStionable		
:[EVENT]?		[query only, always returns "0"]
:CONDition?		[query only, always returns "0"]
:ENABle	<numeric value>	[implemented but not useful]
SYSTEM:		
:COMMunicate		
:GPIB		
:ADDReSS	<numeric value>	
:SERial		
:CONTRol		
:RTS	ON   IBFull   RFR	
:[RECeive]		
:BAUD	1200   2400   4800   9600   19200   38400   57600   115200	
:ERRor		
:[NEXT]?		[query only]
:COUNT?		[query only]
:VERSion?		[query only]
TRIGger:		
:SOURce	INTernal   EXTernal   MANual   HOLD   IMMEDIATE	
*CLS		[no query form]
*ESE	<numeric value>	
*ESR?		[query only]
*IDN?		[query only]
*OPC		
*SAV	0   1   2   3	[no query form]
*RCL	0   1   2   3	[no query form]
*RST		[no query form]
*SRE	<numeric value>	
*STB?		[query only]
*TST?		[query only]
*WAI		[no query form]

## MECHANICAL INFORMATION

### TOP COVER REMOVAL

If necessary, the interior of the instrument may be accessed by removing the four Phillips screws on the top panel. With the four screws removed, the top cover may be slid back (and off).

 Always disconnect the power cord and allow the instrument to sit unpowered for 10 minutes before opening the instrument. This will allow any internal stored charge to discharge.

There are no user-adjustable internal circuits. For repairs other than fuse replacement, please contact Avtech (info@avtechpulse.com) to arrange for the instrument to be returned to the factory for repair. Service is to be performed solely by qualified service personnel.

 Caution: High voltages are present inside the instrument during normal operation. Do not operate the instrument with the cover removed.

### RACK MOUNTING

A rack mounting kit is available. The -R5 rack mount kit may be installed after first removing the one Phillips screw on the side panel adjacent to the front handle.

### ELECTROMAGNETIC INTERFERENCE

To prevent electromagnetic interference with other equipment, all used outputs should be connected to shielded loads using shielded coaxial cables. Unused outputs should be terminated with shielded coaxial terminators or with shielded coaxial dust caps, to prevent unintentional electromagnetic radiation. All cords and cables should be less than 3m in length.

## MAINTENANCE

### REGULAR MAINTENANCE

This instrument does not require any regular maintenance.

On occasion, one or more of the four rear-panel fuses may require replacement. All fuses can be accessed from the rear panel. See the “FUSES” section for details.

### CLEANING

If desired, the interior of the instrument may be cleaned using compressed air to dislodge any accumulated dust. (See the “TOP COVER REMOVAL” section for instructions on accessing the interior.) No other cleaning is recommended.





# PCB 158R5 - LOW VOLTAGE POWER SUPPLY

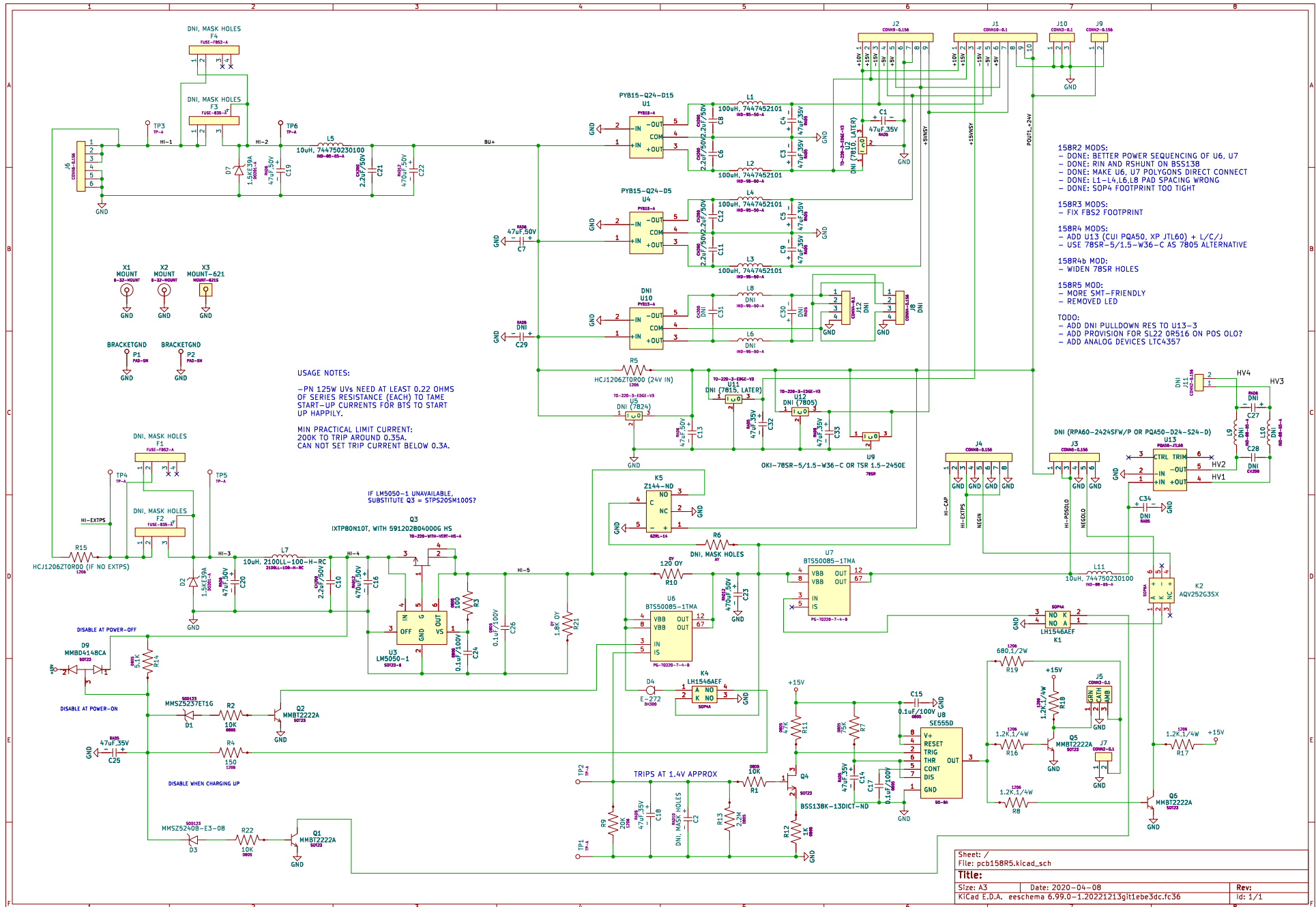

# PCB 104H - KEYPAD / DISPLAY BOARD

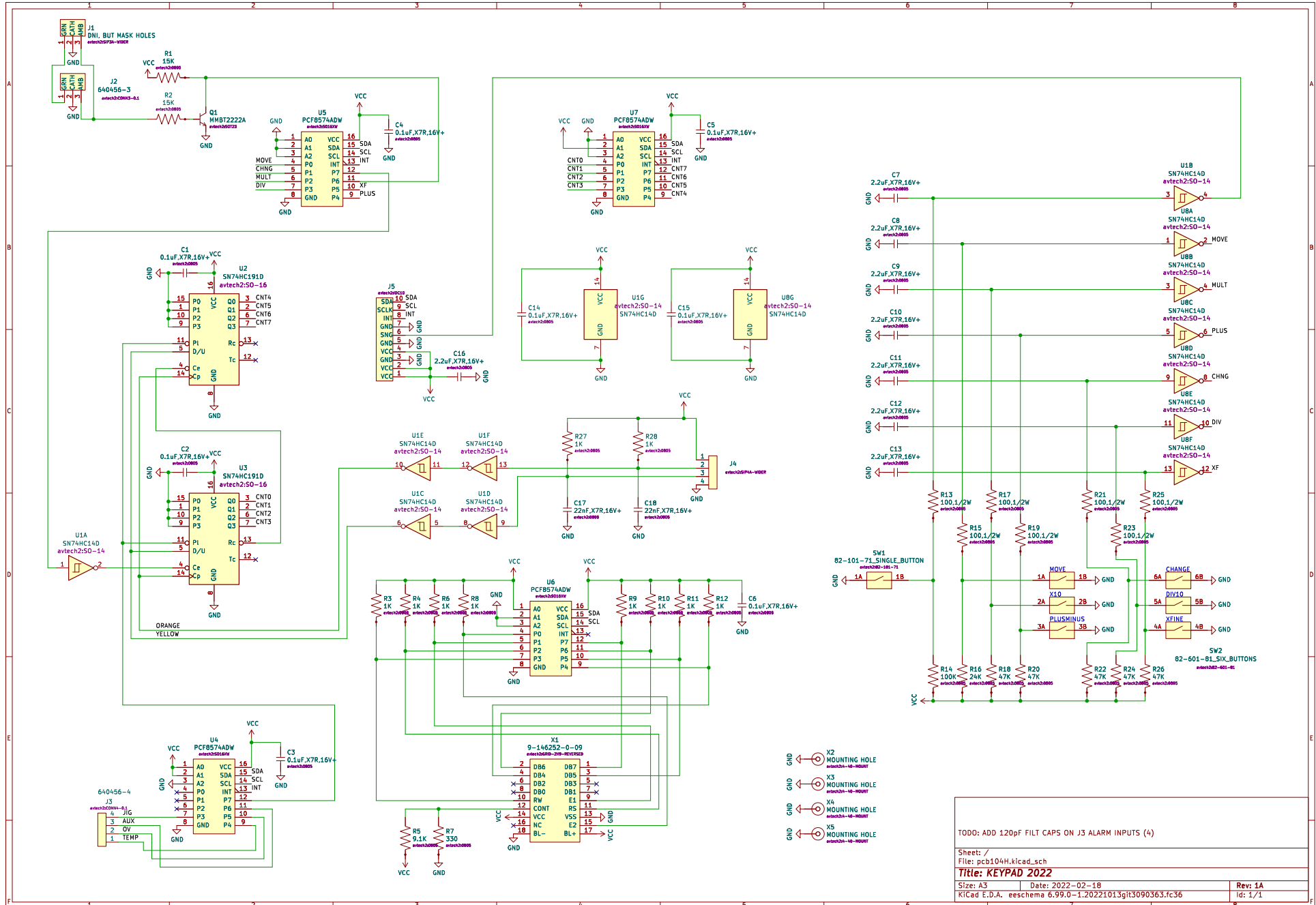

# PCB 100B - PULSE GENERATOR, 1 / 4

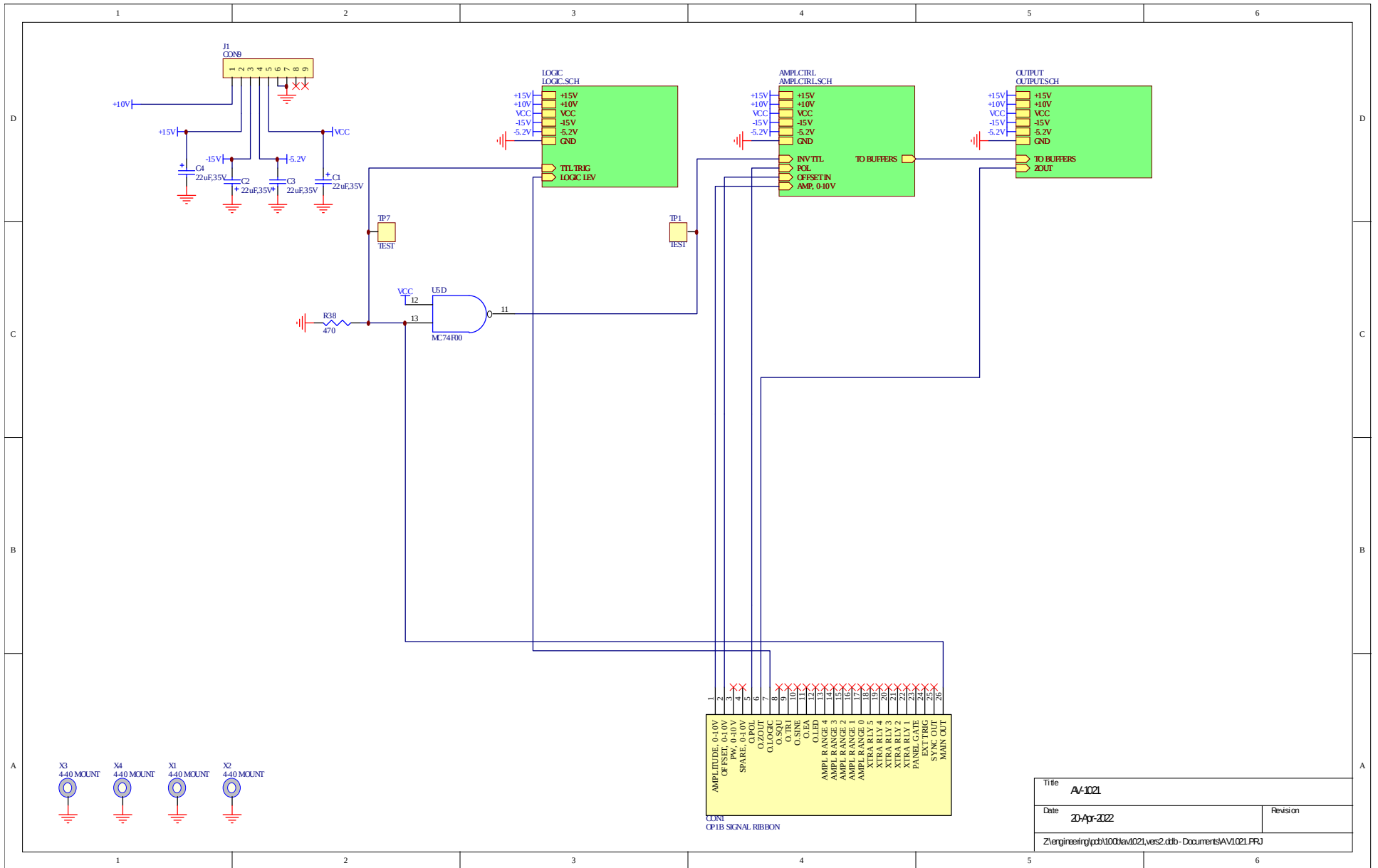

Title		A-1021
Date	20-Apr-2022	Revision
Z:\engineering\pcb\100b\ev021\vers2.dtb - Documents\AV1021.PRJ		

# PCB 100B - PULSE GENERATOR, 2 / 4

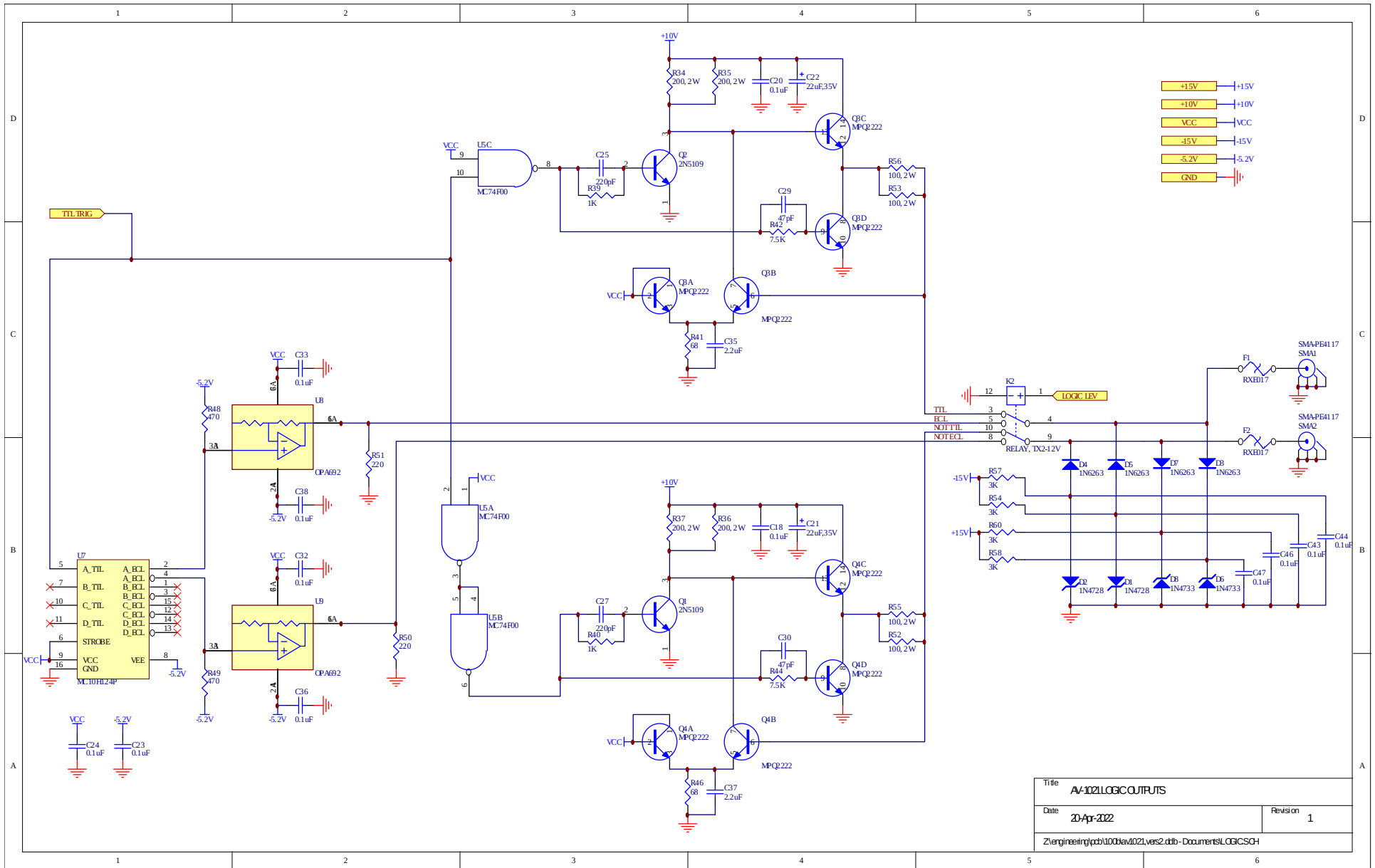

# PCB 100B - PULSE GENERATOR, 3 / 4

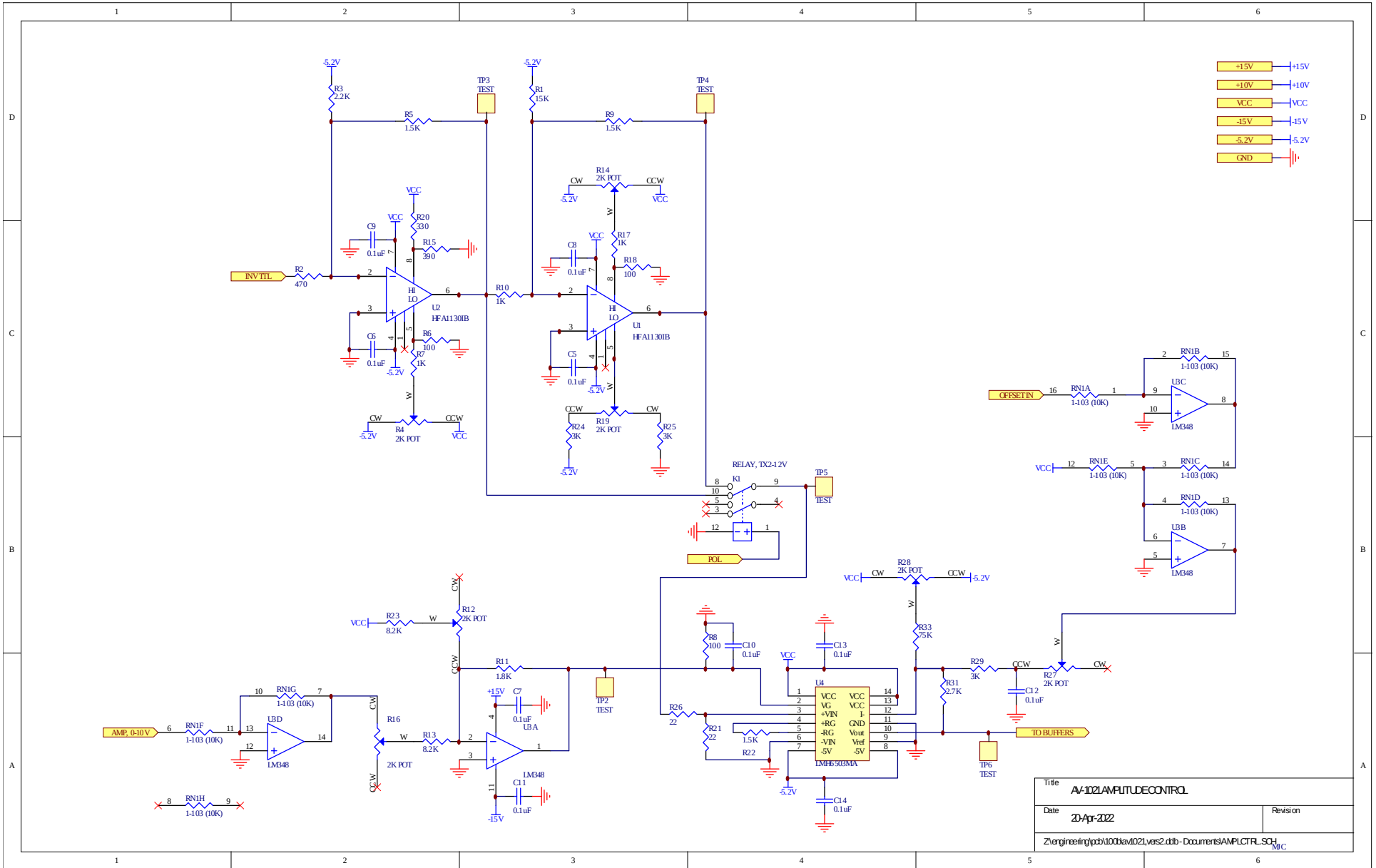

# PCB 100B - PULSE GENERATOR, 4 / 4

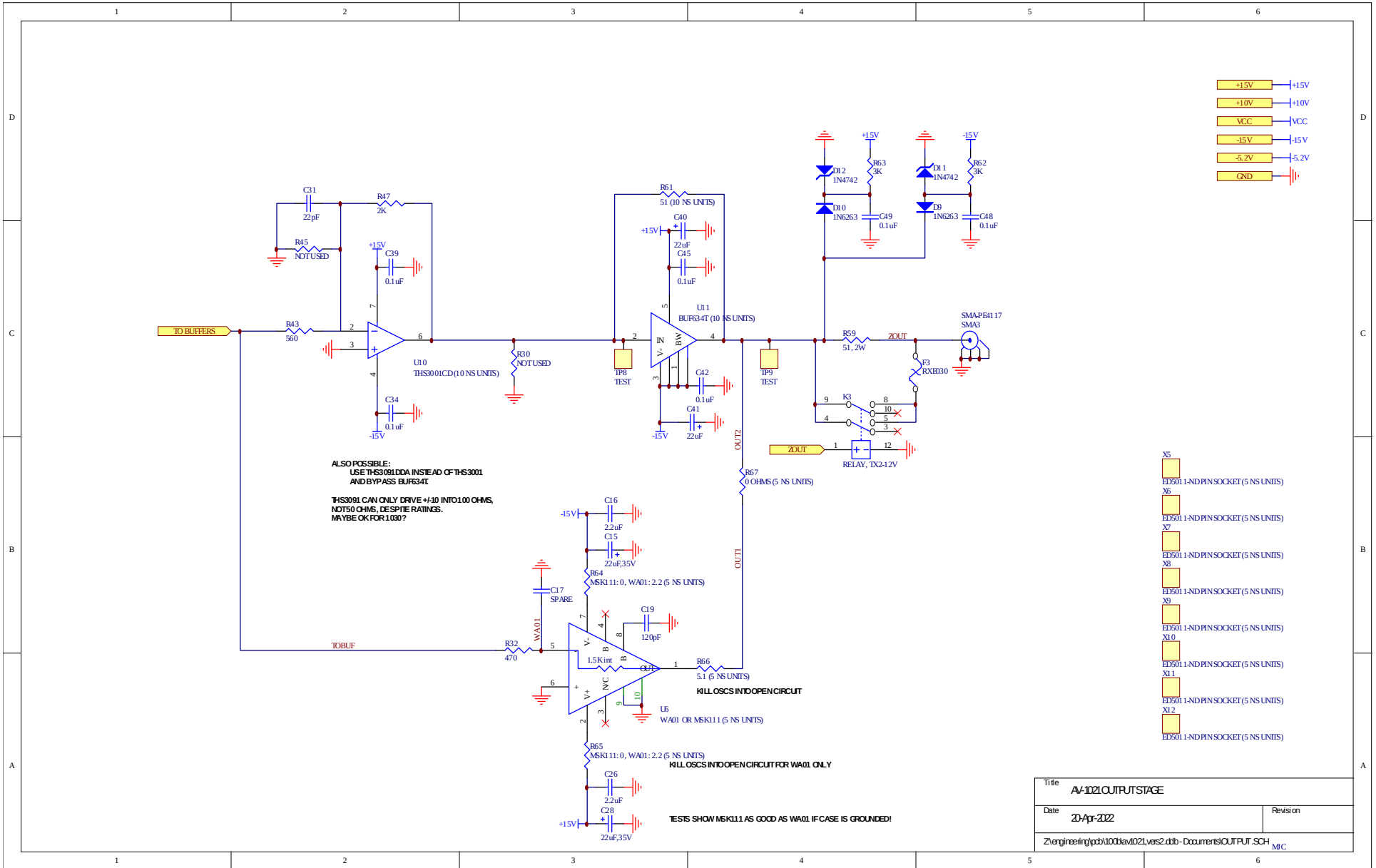

# MAIN WIRING

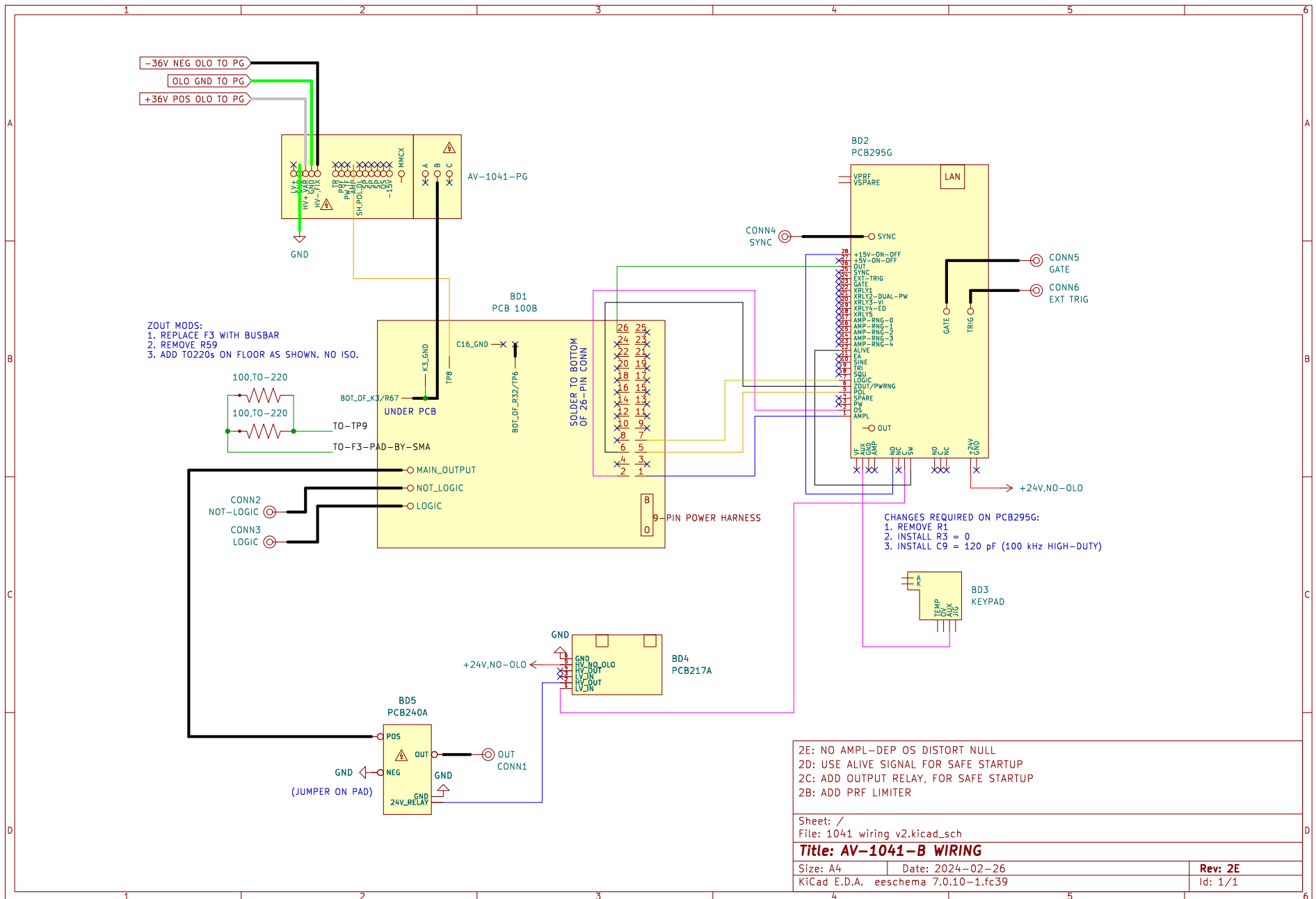



PERFORMANCE CHECK SHEET