

INSTRUCTIONS

MODEL AV-107D-B

0 to 20 AMP, 0 to 60 V, 30 ns RISE TIME
LASER DIODE DRIVER
WITH IEEE 488.2 AND RS-232 CONTROL

SERIAL NUMBER: _____

WARRANTY

Avtech Electrosystems Ltd. warrants products of its manufacture to be free from defects in material and workmanship under conditions of normal use. If, within one year after delivery to the original owner, and after prepaid return by the original owner, this Avtech product is found to be defective, Avtech shall at its option repair or replace said defective item. This warranty does not apply to units which have been disassembled, modified or subjected to conditions exceeding the applicable specifications or ratings. This warranty is the extent of the obligation assumed by Avtech with respect to this product and no other warranty or guarantee is either expressed or implied.

TECHNICAL SUPPORT

Phone: 613-226-5772 or 1-800-265-6681

Fax: 613-226-2802 or 1-800-561-1970

E-mail: info@avtechpulse.com

World Wide Web: <http://www.avtechpulse.com>

TABLE OF CONTENTS

WARRANTY	2
TECHNICAL SUPPORT	2
TABLE OF CONTENTS	3
INTRODUCTION	5
SPECIFICATIONS	7
INSTALLATION	8
VISUAL CHECK	8
PLUGGING IN THE INSTRUMENT	8
CONNECTING THE OUTPUT MODULE TO THE MAINFRAME	8
MAINFRAME FRONT PANEL CONTROLS	9
MAINFRAME REAR PANEL CONTROLS	11
OUTPUT MODULE CONTROLS AND CONNECTORS	12
GENERAL INFORMATION	13
BASIC TEST ARRANGEMENT	13
CURRENT MEASUREMENT	14
BASIC PULSE CONTROL	15
TRIGGER MODES	16
GATING MODES	17
TOP COVER REMOVAL	17
RACK MOUNTING	17
LOAD PROTECTION	18
LENZ'S LAW AND INDUCTIVE VOLTAGE SPIKES	18
ATTACHING AND DETACHING LOADS	18
CHANGING PARAMETERS WHEN A LOAD IS ATTACHED	18
START-UP CHECK-LIST FOR LOCAL CONTROL	19
CALIBRATION ADJUSTMENTS - SOFTWARE PROCEDURES	21
ADJUSTING AMPLITUDE ACCURACY	21
PROGRAMMING YOUR PULSE GENERATOR	22
KEY PROGRAMMING COMMANDS	22
ALL PROGRAMMING COMMANDS	23

SYSTEM DESCRIPTION AND REPAIR PROCEDURE _____ **25**
PERFORMANCE CHECK SHEET _____ **27**

Manual Reference: /fileserver1/officefiles/instructword/av-107/AV-107D-B.doc, created November 28, 2000

INTRODUCTION

The Model AV-107D-B pulse generator is designed for pulsing laser diode and other low impedance loads with rectangular pulses as high as 20 Amperes into load voltages up to 60V, with 30 ns rise and fall times. The pulse repetition frequency can vary from 1 Hz to 500 Hz, and pulse widths can vary from 50 ns to 5 μ s. The current and voltage polarities depend on the model number:

"-P" units: 0 to +20 A amplitude, 0 to +60V compliance

"-N" units: 0 to -20 A amplitude, 0 to -60V compliance

"-PN" units: 0 to \pm 20 A amplitude, 0 to +60V compliance for positive output, and 0 to -60V compliance for negative output.

The Model AV-107D-B pulse generator is a current pulser. The current amplitude is largely independent of the load voltage. The load voltage must not exceed 60V.

The AV-107D-B system consists of an instrument mainframe and an output module (the AV-107D-P-PG for positive units, the AV-107D-N-PG for negative units. Dual polarity units have both output modules.) The output module connects to the mainframe using two cables: a 25-conductor cable, detachable at the mainframe end, carries the control signals, and a single-conductor shielded RG-58 cable, detachable at both ends, carries the high voltage power supply (+100V or -100V).

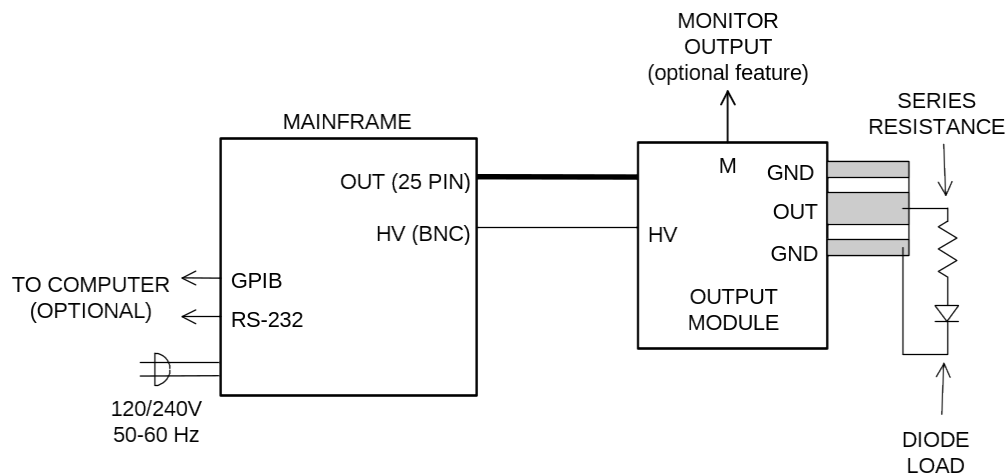

The loads can be connected (soldered) to the microstrip transmission line that protrudes from the output module. The lead lengths must not exceed several centimeters or severe inductive voltage spikes will result (as predicted by Lenz's Law.)

For instruments with the "-M" option, a current monitor output is present on the output module.

The AV-107D-B has two amplitude ranges, of 0 to 4A and 4 to 20A, allowing the instrument to be used at both moderate and high current levels. (The instrument automatically selects the appropriate range based on the amplitude setting.)

The AV-107D-B can be controlled from the front panel, or via a computer connected to the IEEE 488.2-compliant GPIB port, or the RS-232 serial port.

SPECIFICATIONS

Model:	AV-107D-B
GPIB, RS-232 control:	Standard on -B units.
Amplitude: -P units:	0 to +20 Amperes
-N units:	0 to -20 Amperes
-PN units:	0 to \pm 20 Amperes
Pulse width:	50 ns to 5 us
Rise time, fall time:	\leq 30 ns
Duty Cycle:	0.25% maximum
PRF:	1 Hz to 500 Hz
Current regulation:	Load voltage change from 0 to 60 Volts: \leq 5%
Load voltage range:	
-P units:	0 to +60 Volts
-N units:	0 to -60 Volts
-PN units:	0 to +60 Volts for positive output, 0 to -60 Volts for negative output
Propagation delay, (Jitter):	\leq 100 ns, (\pm 100 ps \pm 0.03% of sync delay, Ext trig in to pulse out)
Ext. trigger in:	+ 5 Volts, 50 ns or wider (TTL)
Sync delay: (sync to pulse out)	0 to \pm 5 us
Sync output:	+ 3 Volt, 200 ns, will drive 50 Ohm loads
Gate input:	Synchronous or asynchronous, active high or low, switchable. Suppresses triggering when active.
Connectors:	Out: Solder terminals Trig: BNC Sync: BNC Gate: BNC HV: SMA
Power requirements:	120/240 Volts (switchable) 50 - 60 Hz
Dimensions:	Mainframe: 100 x 215 x 375 mm (3.9" x 8.5" x 14.8") Output module: 109 x 66 x 43 mm (4.3" x 2.6" x 1.7")
Temperature range:	+ 10° to + 40° C

INSTALLATION

VISUAL CHECK

After unpacking the instrument mainframe and the two output modules, examine to ensure that they have not been damaged in shipment. Visually inspect all connectors, knobs, liquid crystal displays (LCDs), and the handles. Confirm that a power cord and two instrumentation manuals (this manual and the "OP1B Interface Programming Manual") are with the instrument. If the instrument has been damaged, file a claim immediately with the company that transported the instrument.

PLUGGING IN THE INSTRUMENT

Examine the rear of the instrument. There will be a male power receptacle, a fuse holder and the edge of the power selector card visible.

For AC line voltages of 110-120V, the power selector card should be installed so that the "120" marking is visible from the rear of the instrument.

For AC line voltages of 220-240V, the power selector card should be installed so that the "240" marking is visible from the rear of the instrument.

If it is not set for the proper voltage, remove the fuse and then grasp the card with a pair of pliers and remove it. Rotate horizontally through 180 degrees. Reinstall the card and the correct fuse.

In the 120V setting, a 1A slow blow fuse is required. In the 240V setting, a 0.5A slow-blow fuse is required.

CONNECTING THE OUTPUT MODULE TO THE MAINFRAME

The output module and the mainframe should be connected together as shown on page 13. The gray cable mates to the multi-pin "OUT" connector on the rear panel. The black RG-174 cable connects to the "HV" SMA connector. Note that the output module should be attached to a heatsink capable of dissipating 5 Watts if minimizing long-term drift of the output amplitude is critical.

MAINFRAME FRONT PANEL CONTROLS

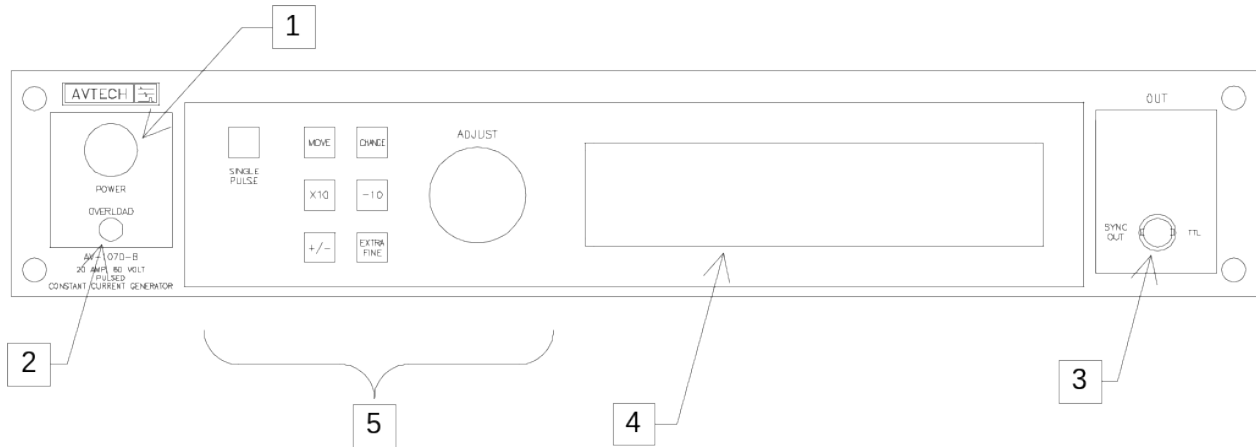

1. **POWER Switch.** The POWER push button switch applies AC prime power to the primaries of the transformer, turning the instrument on. The push button lamp (#382 type) is connected to the +15V DC supply.
2. **OVERLOAD.** A protective circuit controls the front panel overload light. This indicator will light if the output module is overheating. (An audible buzzer will also sound, and the trigger will be disabled.) This may occur at high duty cycles when driving a low-impedance load. See the "High Duty Cycle Operation" section for methods of avoiding overheating.
3. **SYNC OUT.** This connector supplies a SYNC output that can be used to trigger other equipment, particularly oscilloscopes. This signal leads, or lags, the main output by a duration set by the "DELAY" controls and has an approximate amplitude of +3 Volts to $R_L > 1k\Omega$ with a pulse width of approximately 200 ns.
4. **LIQUID CRYSTAL DISPLAY (LCD).** This LCD is used in conjunction with the keypad to change the instrument settings. Normally, the main menu is displayed, which lists the key adjustable parameters and their current values. The "OP1B Interface Programming Manual" describes the menus and submenus in detail.

5. KEYPAD.

Control Name	Function
MOVE	This moves the arrow pointer on the display.
CHANGE	This is used to enter the submenu, or to select the operating mode, pointed to by the arrow pointer.
×10	If one of the adjustable numeric parameters is displayed, this increases the setting by a factor of ten.
÷10	If one of the adjustable numeric parameters is displayed, this decreases the setting by a factor of ten.
+/-	If one of the adjustable numeric parameters is displayed, and this parameter can be both positive or negative, this changes the sign of the parameter.
EXTRA FINE	This changes the step size of the ADJUST knob. In the extra-fine mode, the step size is twenty times finer than in the normal mode. This button switches between the two step sizes.
ADJUST	This large knob adjusts the value of any displayed numeric adjustable values, such as frequency, pulse width, etc. The adjust step size is set by the "EXTRA FINE" button. When the main menu is displayed, this knob can be used to move the arrow pointer.

MAINFRAME REAR PANEL CONTROLS

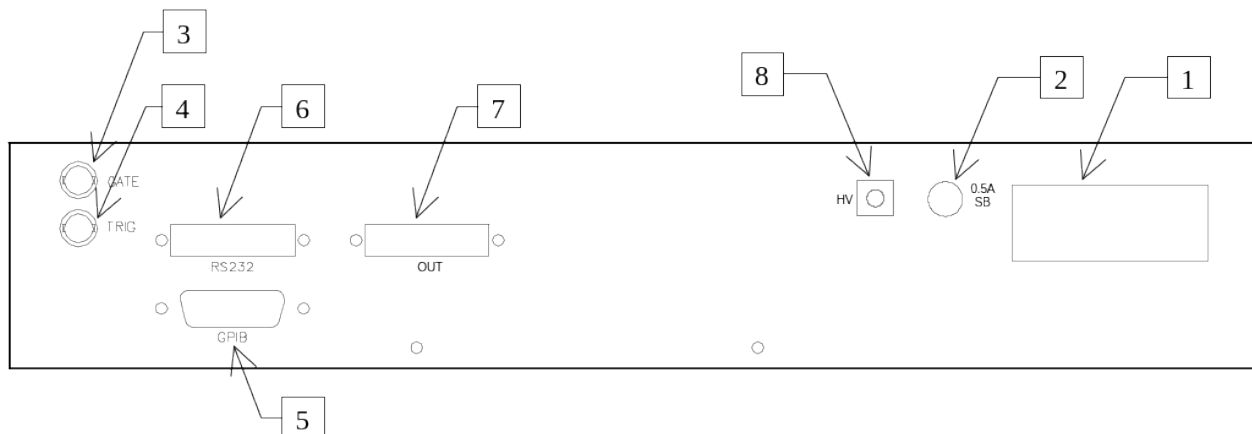

Note: Dual polarity "-PN" models will have one "OUT" connector for each polarity.

1. **AC POWER INPUT.** A three-pronged recessed male connector is provided on the back panel for AC power connection to the instrument. Also contained in this assembly is a 1A slow blow fuse and a removable card that can be removed and repositioned to switch between 120V AC in and 240V AC in.
2. **DC FUSE.** This 0.5A slow-blow fuse protects the internal DC power supply.
3. **GATE.** This TTL-level (0 and +5V) logic input can be used to gate the triggering of the instrument. This input can be either active high or active low, depending on the front panel settings or programming commands. (The instrument triggers normally when this input is unconnected).
4. **TRIG.** This TTL-level (0 and +5V) logic input can be used to trigger the instrument, if the instrument is set to triggering externally. The instrument triggers on the rising edge of this input.
5. **GPIB Connector.** A standard GPIB cable can be attached to this connector to allow the instrument to be computer-controlled. See the "OP1B Interface Programming Manual" for more details on GPIB control.
6. **RS-232 Connector.** A standard serial cable with a 25-pin male connector can be attached to this connector to allow the instrument to be computer-controlled. See the "OP1B Interface Programming Manual" for more details on RS-232 control.
7. **OUT.** The 25-pin cable from the negative output module is connected to this connector.
8. **HV SMA Connector.** The shielded RG-174 cable from the output module is connected to this connector. This carries the high-voltage power supply (+100V or -100V, depending on the output polarity) to the output module.

OUTPUT MODULE CONTROLS AND CONNECTORS

OUT Microstrip Line

The main output is provided on the center conductor of the microstrip board protruding from the output module. The outer two conductors, as well as the reverse side of the microstrip board are connected to ground.

A typical connection scheme (for positive output current) is shown below:

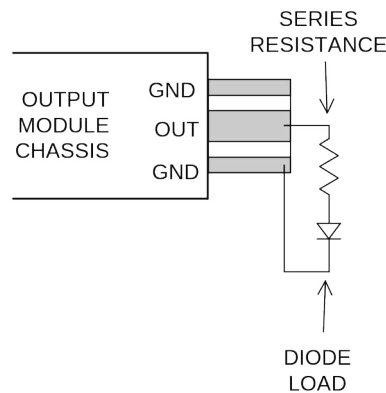

The load should be connected between the OUT and GND terminals using very short leads (<5.0 cm, and preferably < 0.5 cm). Severe inductive voltage spikes will result from any series inductance (Lenz's Law). Take care to ensure that during soldering the OUT conductor is not shorted to the chassis. Use minimal heat when soldering to avoid delaminating the metal pads.

If the load cannot be placed directly on the output terminals of the -PG module, the AV-LZ lines should be used between the -PG module and the load (see the Avtech AV-LZ data sheet, available at www.avtechpulse.com).

GENERAL INFORMATION

BASIC TEST ARRANGEMENT

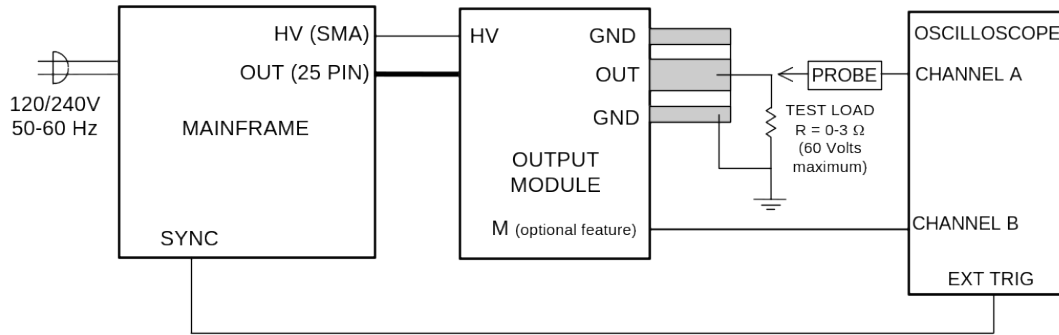

The equipment should be connected in the general fashion shown above (see page 8 also). For dual-polarity instruments, both output modules should be connected, with the positive output module connected to the "OUT P" connector, and the negative output module connected to the "OUT N" connector. Only one of the HV cables can be connected to the HV connector at a time. Connect the HV cable for the polarity that will be used.

Output modules should always be connected to the mainframe **BEFORE power is applied**.

Proper choice of test resistance is important. It is essential that the resistive test load be low-inductance. (Wirewound resistors are not acceptable, unless many are connected together in parallel.) The power dissipated in the resistor is given by

$$P_{\text{AVERAGE}} = I^2 \times R \times \frac{PW}{T}, \quad P_{\text{PEAK}} = I^2 \times R$$

where "I" is the current, "R" is the resistance, "PW" is the pulse width, and "T" is the pulse period (1/frequency).

The power rating of the resistance should exceed this average power rating by a large margin. Beware that some low-value resistors exhibit a significant temperature-dependence, even when the average power dissipated is below the resistor's power rating. This is particularly true if the peak power exceeds the resistor's power rating.

Factory tests are conducted with a 2 Ω load capable of dissipating at least 5 W. Higher load resistance values may be used but the output voltage must be limited to 60V or less.

CURRENT MEASUREMENT

Measuring current is more difficult than measuring voltage. There are four basic approaches to measuring pulsed current:

1. Rely on the accuracy of the amplitude setting (typically 5%), as displayed on the LCD display.
2. Use a high-performance current transformer, such as a Pearson 2878. The output voltage of the transformer is proportional to the sensed current. Note that because of the relatively large size of the 2878, it is necessary to introduce a significant lead length (i.e., inductance) to pass the conductor through the transformer.
3. Use a low-resistance, low-inductance, current-sensing resistor connected in series with the load. To minimize inductance, it is usually wise to connect several resistors in parallel. Beware that wirewound resistors usually have far too much inductance to be useful as current-sensing resistors.
4. Instruments with the "-M" option include two monitor outputs on the output module. The upper-most M connector, labeled "PW MIN", is the output of a high-speed current transformer, capable. It will accurately show the output rise time, but since it is AC-coupled, the output will droop at wide pulse widths (i.e. > 3 us).

The load current (I_L) and the voltage at "M" (V_M) are related by:

$$V_M = I_L \times 0.1 \text{ Amp/Volt, approximately.}$$

The lower M connector, labeled "PW MAX", is the amplified output of a DC-coupled current-sensing resistance. This output has a rise-time of approximately 2 us, which is slower than the rise time of the main output, but it can operate at wide pulse widths. The load current (I_L) and the voltage at "M" (V_M) are related by:

$$V_M = I_L \times 0.35 \text{ Volt/Amp, approximately.}$$

The "M" voltage waveform should normally be displayed on an oscilloscope.

BASIC PULSE CONTROL

This instrument can be triggered by its own internal clock or by an external TTL trigger signal. In either case, two output channels respond to the trigger: OUT and SYNC. The OUT channel is the signal that is applied to the device under test. Its amplitude and pulse width are variable. The SYNC pulse is a fixed-width TTL-level reference pulse used to trigger oscilloscopes or other measurement systems. When the delay is set to a positive value the SYNC pulse precedes the OUT pulse.

These pulses are illustrated below, assuming internal triggering, positive delay, and a positive output:

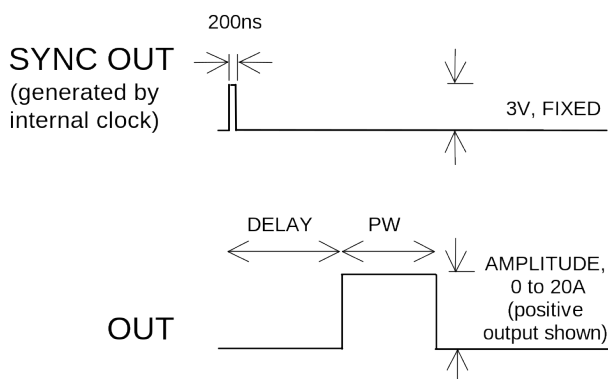

Figure A

If the delay is negative, the order of the SYNC and OUT pulses is reversed:

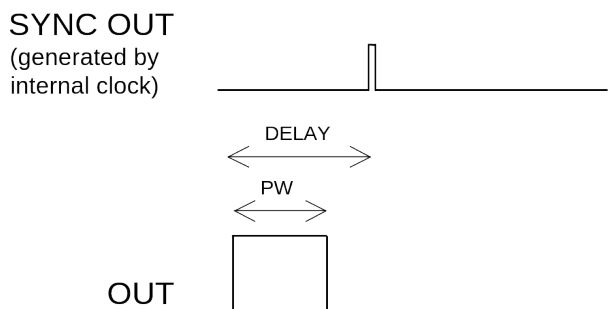

Figure B

The next figure illustrates the relationship between the signal when an external TTL-level trigger is used:

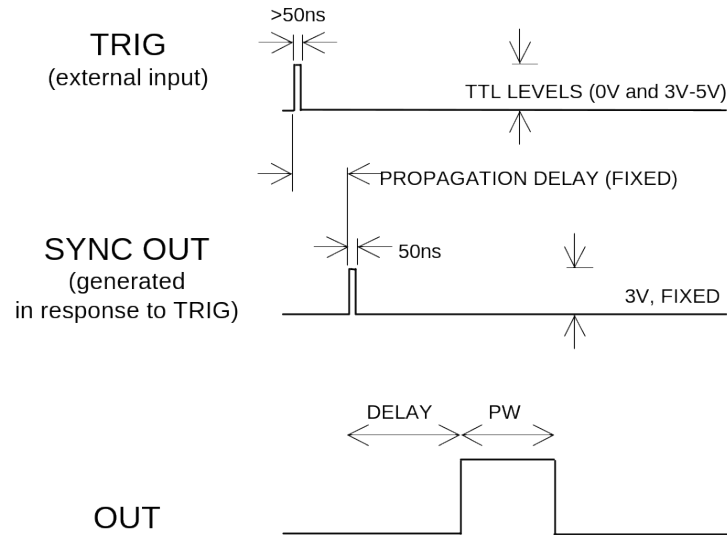

Figure C

As before, if the delay is negative, the order of the SYNC and OUT pulses is reversed.

The delay, pulse width, and frequency (when in the internal mode), of the OUT pulse can be varied with front panel controls or via the GPIB or RS-232 computer interfaces.

TRIGGER MODES

This instrument has four trigger modes:

- **Internal Trigger:** the instrument controls the trigger frequency, and generates the clock internally.
- **External Trigger:** the instrument is triggered by an external TTL-level clock on the back-panel TRIG connector.
- **Manual Trigger:** the instrument is triggered by the front-panel "SINGLE PULSE" pushbutton.
- **Hold Trigger:** the instrument is set to not trigger at all.

These modes can be selected using the front panel trigger menu, or by using the appropriate programming commands. (See the "OP1B Interface Programming Manual" for more details.)

GATING MODES

Triggering can be suppressed by a TTL-level signal on the rear-panel GATE connector. The instrument can be set to stop triggering when this input high or low, using the front-panel gate menu or the appropriate programming commands. This input can also be set to act synchronously or asynchronously. When set to asynchronous mode, the GATE will disable the output immediately. Output pulses may be truncated. When set to synchronous mode, the output will complete the full pulse width if the output is high, and then stop triggering. No pulses are truncated in this mode.

TOP COVER REMOVAL

The top cover of the instrument may be removed by removing the four Phillips screws on the top panel. With these four screws removed, the top panel may be slid off by pulling it towards the rear.

RACK MOUNTING

A rack mounting kit is available. The -R5 rack mount kit may be installed after first removing the one Phillips screw on the side panel adjacent to the front handle.

LOAD PROTECTION

LENZ'S LAW AND INDUCTIVE VOLTAGE SPIKES

This instrument is designed to pulse resistive and diode loads and will exhibit a large output spike when used to drive a load with significant inductance (as predicted by LENZ'S LAW). For this reason the load should be connected to the output using low inductance leads (as short as possible and as heavy a gauge as possible).

The voltage developed across an inductance L (in Henries), when the current is changing at a rate given by di_{LOAD}/dt (in Amps/sec), is: $V_{SPIKE} = L \frac{di_{LOAD}}{dt}$.

Some load inductance is unavoidable. As a result, the output voltage waveform (measured across a resistance) will have some distortion on the leading edge, as shown:

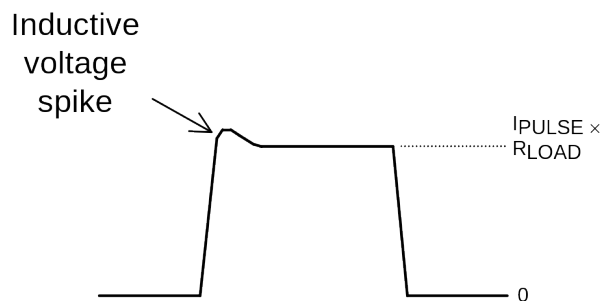

Attaching a current transformer (for measuring current waveforms) can add significant inductance, because of the necessary wire length that must be fed through the transformer. (The Pearson 2878 requires approximately 1.5".) For this reason it is recommended that the optional self-contained current transformer ("M") be used.

ATTACHING AND DETACHING LOADS

To avoid damaging the loads connected to main outputs, the loads should only be connected to or removed from the instrument when the instrument is off. Do not connect loads when the instrument is on and the output amplitude is not zero. This can cause sparking.

CHANGING PARAMETERS WHEN A LOAD IS ATTACHED

If your load is easily damaged, the amplitude should be reduced to zero before changing the trigger source, frequency, pulse width, or other pulse parameters. This protects the loads from possible short transient effects.

START-UP CHECK-LIST FOR LOCAL CONTROL

- 1) The instruction manual has been studied thoroughly.
- 2) The "Local Control" section of the "OP1B Interface Programming Manual" has been studied thoroughly.
- 3) The output module is connected to the mainframe as shown in the "Basic Test Arrangement" section. (The output module should always be connected to the mainframe BEFORE power is applied.)
- 4) The load is connected to the output module microstrip output. The center conductor is the output line, and the two outer conductors are connected to ground. For initial testing, it is recommended that a resistive load be used. Factory tests are conducted using a 2 Ohm, 5 Watt resistive load.

These tests may also be conducted using a diode load. In this case, for -P units (or when using the positive output module of a "-PN" unit), the diode anode should be connected to the wide center microstrip on the output circuit board, and the cathode should be connected to either of the narrow outer microstrips. For -N units (or when using the negative output module of a "-PN" unit), the diode cathode should be connected to the wide center microstrip on the output circuit board, and the anode should be connected to either of the narrow outer microstrips.

- 5) Attach an oscilloscope probe to the load.
- 6) Turn on the prime power to the mainframe. The main menu will appear.
- 7) The arrow pointer should be pointing at the frequency menu item. If it is not, press the MOVE button until it is.
- 8) Press the CHANGE button. The frequency submenu will appear. Rotate the ADJUST knob until the frequency is set at the desired setting. The arrow pointer should be pointing at the "Internal" choice. If it is not, press MOVE until it is.
- 9) Press CHANGE to return to the main menu.
- 10) Press the MOVE button to move the arrow pointer to the pulse width menu item. Press CHANGE to bring up the pulse width submenu, and rotate the ADJUST knob until the pulse width is set at the desired setting. The arrow pointer should be pointing at the "Normal" choice. If it is not, press MOVE until it is. Press CHANGE to return to the main menu.

- 11) Press the MOVE button to move the arrow pointer is pointing at the output item. Press CHANGE to bring up the output submenu. The arrow pointer should be initially be pointing at the "Output Off" choice. Press MOVE so that the arrow pointer is pointing at the "Output On" choice. (The mainframe is now supplying a trigger to the output module.) Press CHANGE to return to the main menu.
- 12) Press the MOVE button to move the arrow pointer to the amplitude menu item. Press CHANGE to bring up the amplitude submenu, and rotate the ADJUST knob until the amplitude is set at the desired setting. A rectangular pulse should appear on the scope and the amplitude should increase as the ADJUST knob is rotated.
- 13) Observe the pulse width and pulse period on the scope and confirm that the peak current does not exceed 20 Amps.
- 14) Adjust pulse width, pulse period (i.e. PRF) and amplitude to obtain the desired settings.
- 15) If additional assistance is required:

Tel: (613) 226-5772, Fax: (613) 226-2802
Email: info@avtechpulse.com

CALIBRATION ADJUSTMENTS - SOFTWARE PROCEDURES

ADJUSTING AMPLITUDE ACCURACY

The AV-107D-B has two amplitude ranges: 0 to 4A, and 4A to 20A, approximately. The calibration of each range can be adjusted by a few percent if necessary.

If it is found that the output amplitude settings (as set by the front-panel controls or programming commands) do not agree exactly with measured values of amplitude (i.e., by examining the output on an oscilloscope) in one of these ranges, the amplitude calibration can be updated using software commands.

The following procedure is suggested:

- 1) Connect a precision, high-power resistive load to the output. (As an example, suppose 2 Ω is used.)
- 2) Connect the pulse generator to a computer using the GPIB or RS232 ports.
- 3) Turn on the pulse generator, and set the time controls (frequency, delay, pulse width) to typical values.
- 4) Turn on the outputs.
- 5) Set the output amplitude to 80% of the maximum current for that range. For instance, if the 0 to 20A range requires calibration, set the amplitude to 16A.
- 6) Observe the voltage across the load. (Using the 2 Ω example, suppose that 34V is observed.) From this, calculate the measured current (17 A in this example).
- 7) Send the measured value to the instrument using the following command:

```
diag:ampl:cal 17 A
```

The internal software compares the supplied measured value to the programmed value, and adjusts the internal calibration data to null out any differences.

- 8) Observe the voltage across the load again. The amplitude setting should now agree with the measured value.

PROGRAMMING YOUR PULSE GENERATOR

KEY PROGRAMMING COMMANDS

The “OP1B Interface Programming Manual” describes in detail how to connect the pulse generator to your computer, and the programming commands themselves. A large number of commands are available; however, normally you will only need a few of these. Here is a basic sample sequence of commands that might be sent to the instrument after power-up:

*rst	(resets the instrument)
trigger:source internal	(selects internal triggering)
frequency 10 Hz	(sets the frequency to 10 Hz)
pulse:width 500 ns	(sets the pulse width to 500 ns)
pulse:delay 200 ns	(sets the delay to 200 ns)
output on	(turns on the output)
source:current 17 A	(sets the current amplitude to 17 amperes)

For triggering a single event, this sequence would be more appropriate:

*rst	(resets the instrument)
trigger:source hold	(turns off all triggering)
pulse:width 500 ns	(sets the pulse width to 500 ns)
output on	(turns on the output)
source:current 17 A	(sets the current amplitude to 17 amperes)
trigger:source immediate	(generates a single non-repetitive trigger event)
trigger:source hold	(turns off all triggering)
output off	(turns off the output)

To set the instrument to trigger from an external TTL signal applied to the rear-panel TRIG connector, use:

*rst	(resets the instrument)
trigger:source external	(selects external triggering)
pulse:width 500 ns	(sets the pulse width to 500 ns)
pulse:delay 200 ns	(sets the delay to 200 ns)
source:current 17 A	(sets the current amplitude to 17 amperes)
output on	(turns on the output)

These commands will satisfy 90% of your programming needs.

ALL PROGRAMMING COMMANDS

For more advanced programmers, a complete list of the available commands is given below. These commands are described in detail in the “OP1B Interface Programming Manual”. (Note: this manual also includes some commands that are not implemented in this instrument. They can be ignored.)

<u>Keyword</u>	<u>Parameter</u>	<u>Notes</u>
DIAGnostic:		
:AMPLitude		
:CALibration:	<numeric value>	[no query form]
LOCAL		
OUTPut:		
:[STATE]	<boolean value>	
:PROTection		
:TRIPped?		[query only]
REMOTE		
[SOURce]:		
:FREQuency		
[:CW FIXed]	<numeric value>	
[SOURce]:		
:CURRent		
[:LEVel]		
[:IMMediate]		
[:AMPLitude]	<numeric value>	
:PROTection		
:TRIPped?		[query only]
[SOURce]:		
:PULSe		
:PERiod	<numeric value>	
:WIDTh	<numeric value>	
:DCYCLE	<numeric value>	
:HOLD	WIDTh DCYCLE	
:DELay	<numeric value>	
:GATE		
:TYPE	ASync SYNC	
:LEVel	HIgh LOw	
STATUS:		
:OPERation		
:[EVENT]?		[query only, always returns "0"]
:CONDition?		[query only, always returns "0"]
:ENABle	<numeric value>	[implemented but not useful]
:QUEStionable		
:[EVENT]?		[query only, always returns "0"]
:CONDition?		[query only, always returns "0"]
:ENABle	<numeric value>	[implemented but not useful]
SYSTem:		
:COMMunicate		
:GPIB		
:ADDReSS	<numeric value>	
:SERial		

:CONTRol		
:RTS	ON IBFull RFR	
:[RECeive]		
:BAUD	1200 2400 4800 9600	
:BITS	7 8	
:ECHO	<boolean value>	
:PARity		
:[TYPE]	EVEN ODD NONE	
:SBITS	1 2	
:ERRor		
:[NEXT]?		[query only]
:COUNT?		[query only]
:VERSion?		[query only]
TRIGger:		
:SOURce	INTernal EXTernal MANual HOLD IMMEDIATE	
*CLS		[no query form]
*ESE	<numeric value>	
*ESR?		[query only]
*IDN?		[query only]
*OPC		
*SAV	0 1 2 3	[no query form]
*RCL	0 1 2 3	[no query form]
*RST		[no query form]
*SRE	<numeric value>	
*STB?		[query only]
*TST?		[query only]
*WAI		[no query form]

SYSTEM DESCRIPTION AND REPAIR PROCEDURE

In the event of an instrument malfunction, it is most likely that the 0.5A slow blow fuse or the main power fuse on the rear panel has failed. Replace if necessary.

If the unit still does not function, it is most likely that some of the output switching elements (SL29T) may have failed due to an output short circuit condition or to a high duty cycle condition. The switching elements may be accessed by removing the cover plate on the bottom side of the output module. The cover plate is removed by removing the four countersunk 6-32 Phillips screws.

NOTE: First turn off the prime power. Briefly ground the SL29T tabs to discharge the 100 Volts power supply potential.

The elements may be removed from their sockets by means of a needle nosed pliers after removing the four counter sunk 2-56 Phillips screws which attach the small copper heat sink to the body of the output module. The SL29T is a selected VMOS power transistor in a TO-220 package and may be checked on a curve tracer. If defective, replacement units should be ordered directly from Avtech. When replacing the SL29T switching elements, take care to ensure that the short lead (of the three leads) is adjacent to the black dots towards the back of the chassis. (See the following illustration). The SL29T elements are electrically isolated from the small copper heat sink but are bonded to the heat sink using Wakefield Type 155 Heat Sink Adhesive.

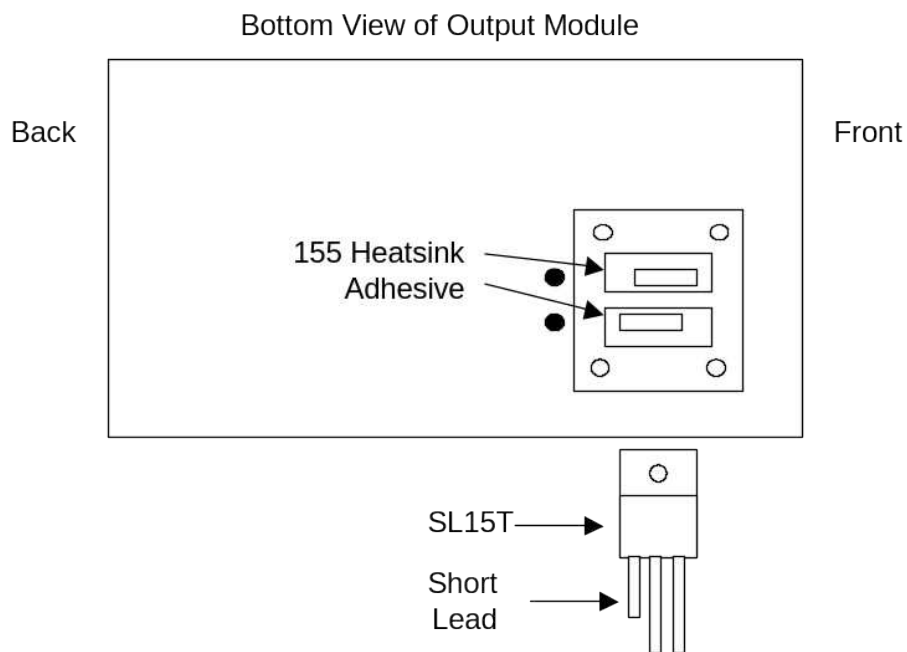

If the switching elements are not defective, then the mainframe timing signal should be checked for proper operation. To do this, disconnect the output module from the mainframe (i.e. both the 25-pin cable and the HV cable). Observe the signal on pin 4 of the 25-pin OUT connector on the rear panel, when in the "Output On" state. This line is the TTL-level (i.e. 0 and +3V) trigger signal for the output module. A signal should be present on this line exactly equal in frequency, and approximately equal in pulse width, to the set values on the front panel. The mainframe and output module should be returned to Avtech if these conditions are not observed.

PERFORMANCE CHECK SHEET