

INSTRUCTIONS

MODEL AV-108A-2-C-N LASER DIODE DRIVER

S.N.:

WARRANTY

Avtech Electrosystems Ltd. warrants products of its manufacture to be free from defects in material and workmanship under conditions of normal use. If, within one year after delivery to the original owner, and after prepaid return by the original owner, this Avtech product is found to be defective, Avtech shall at its option repair or replace said defective item. This warranty does not apply to units which have been disassembled, modified or subjected to conditions exceeding the applicable specifications or ratings. This warranty is the extent of the obligation assumed by Avtech with respect to this product and no other warranty or guarantee is either expressed or implied.

TECHNICAL SUPPORT

Phone: 613-226-5772 or 1-800-265-6681

Fax: 613-226-2802 or 1-800-561-1970

E-mail: info@avtechpulse.com

World Wide Web: <http://www.avtechpulse.com>

TABLE OF CONTENTS

WARRANTY.....	1
TABLE OF CONTENTS.....	2
FIG. 1: PULSE GENERATOR TEST ARRANGEMENT.....	3
GENERAL OPERATING INSTRUCTIONS.....	4
FIG. 2: FRONT PANEL CONTROLS.....	8
FRONT PANEL CONTROLS.....	9
FIG. 3: BACK PANEL CONTROLS.....	11
BACK PANEL CONTROLS.....	12
START-UP CHECK LIST.....	13
TOP COVER REMOVAL.....	15
PERFORMANCE CHECK SHEET.....	16

FIG. 1: PULSE GENERATOR TEST ARRANGEMENT

GENERAL OPERATING INSTRUCTIONS

- 1) The equipment should be connected in the general fashion shown above.
- 2) The mainframe and the -PG module must be connected via the grey cable (to the rear panel RS232 Style "OUT" connector) and by the 4 foot RG58 cable (connects the HV BNC connector on the -PG module and the HV BNC connector on the mainframe rear panel).
- 3) It is recommended that the "Standby/Operate" switch be set to the "Standby" position whenever possible, especially when turning the instrument on or off, when attaching or detaching loads, and when the output is not in use. This switch is part of the "Soft Start" system, which insures the total absence of any harmful spurious output signals during the powering up or power down process. The switch position can be safely changed regardless of the output amplitude setting.
- 4) The output terminals of the pulse generator module consist of a short length of microstrip transmission line protruding from the module chassis. The OUT terminal is the center conductor, which is bounded on both sides by the ground plane (see below). Note that the "OUT" red banana terminal is in parallel with the microstrip center conductor and so may also be used as the output terminal.

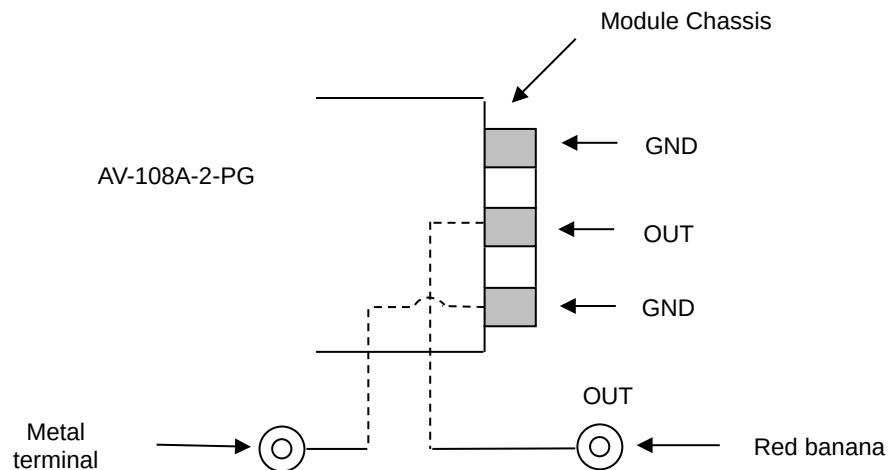

The load should be connected between the OUT and GND terminals using very short leads (≤ 10.0 cm). If the load cannot be placed directly on the output terminals of the -PG module, the AV-LZ lines should be used between the -PG module and the load (see AV-LZ data sheet). Take care to insure that during soldering the OUT conductor is not shorted to the chassis. Also, use minimal heat when soldering.

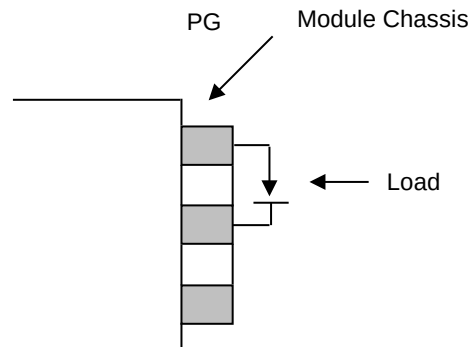

- 5) The current waveform through the diode load may be monitored using a current transformer (available from PEARSON ELECTRONICS or ION PHYSICS INC.) or by using the rear panel monitor output (M). (See paragraph 16).
- 6) When the PW MODE switch is in the INT position, the output pulse width is controlled by the 3-position range switch and a ten turn fine control. **CAUTION:** When setting the pulse width it is critically important that the duty cycle be less than 0.8% (see 10). (See (11) for PW control when the PW MODE switch is in the EXT position).
- 7) The output amplitude is controlled by the front panel ten turn amplitude control (before applying power to the AV-108A-C unit this control should be set fully counterclockwise). To voltage control the amplitude, set the rear panel AMP switch in the EXT position and apply 0 to +10 VDC to the "A" BNC connector.
- 8) The TRIG output channel provides TTL level signals. To avoid overdriving the TRIG input channel of some scopes, a 30 dB attenuator should be placed at the input to the scope trigger channel. The TRIG output precedes the main output when the front panel ADVANCE-DELAY switch is in the ADVANCE position. The TRIG output lags the main output when the switch is in the DELAY position.

- 9) To obtain a stable output display the PW and PRF controls on the front panel should be set mid-range. The front panel INT-EXT-MAN switch should be in the INT position. The DELAY controls and the scope triggering controls are then adjusted to obtain a stable output. The scope may then be used to set the desired PRF by rotating the PRF controls. CAUTION: Take exceptional care to insure that the duty cycle does not exceed 0.8% (see 10 below).
- 10) CAUTION: The AV-108A-2-C may be damaged if operated at duty cycles exceeding 0.8%. For example, if the PW is set at 100 us, the PRF must not exceed 80 Hz. Therefore, take extreme care when setting the pulse width and PRF controls to insure that the duty cycle is less than 0.8% since damage due to excess duty cycle operation is not covered by the warranty.
- 11) An external clock may be used to control the output PRF of the AV-108 unit by setting the front panel INT-EXT toggle switch in the EXT position and applying a 50 ns (or wider) TTL level pulse to the TRIG BNC connector input.
- 12) For single pulse manual operation, set the front panel INT-EXT-MAN switch in the MAN position and push the SINGLE PULSE button.
- 13) The DELAY control controls the relative delay between the reference output pulse provided at the TRIG output and the main output. This delay is variable over the range of 1.0 us to 1 ms. The TRIG output precedes the main output when the ADVANCE-DELAY switch is in the ADVANCE position and lags when the switch is in the DELAY position.

	MIN	MAX
Range 1	1.0 us	10 us
Range 2	10 us	100 us
Range 3	100 us	1 ms

- 14) The AV-108A-2-C is designed to supply up to 100 Amperes peak to a maximum load voltage of 50 Volts. Factory tests are conducted with 0.1 and 0.5 Ohm resistors capable of dissipating at least 40 Watts. Higher load resistance values may be used but the load voltage must be limited to 50 Volts or less. Note that the unit will cease to operate as a constant current source if the load voltage exceeds 50 Volts.

- 15) OVERLOAD PROTECTION:
- a) Model AV-108A-2-C includes a temperature limit circuit which inhibits triggering of the output module and activates the overload LED if the temperature of the output stage switching elements exceeds +50°C. Triggering of the output module will automatically resume (and the overload LED turn off) after the output modules cool to below +50°C. To reduce heating of the output module, reduce the duty cycle to less than 0.8%.
 - b) The maximum DC current supplied to the output module is limited by the rear panel 1.5 A SB fuse. Exceeding a duty cycle of 0.8% for a peak load current of 100 Amperes will cause this fuse to blow.
 - c) The prime power supplied to the output stage is limited and if attempts are made to exceed the rated duty cycle at the peak output current the desired output amplitude will not be attained.
 - d) A 1.5 Amp line fuse (for 120V operation) or a 0.75 Amp line fuse (for 240V operation) will inhibit attempts to exceed the specified maximum duty cycle.
- 16) The rear panel monitor output SMA (M) provides an output voltage (to 50 Ohms or higher) which is linearly proportional to the current flowing through the output terminals (1.0 Volts = 100 Amps). The pulse width (and general wave shape) at M is a replica of the load current but the monitor output may exhibit a spurious DC offset component which should be ignored.
- 17) CURRENT LIMIT CONTROLS. The P1 and P4 ten turn trim pots (on the -PG module) may be used to limit the peak output current to less than 100 Amps. Rotating P1 CCW will cause the peak output current to be less than 100 Amps when the AMP control is set at max CW. The AMP control will still be active (basically linear) over its full range of rotation. Rotating P4 CCW will cause the output to abruptly limit at less than 100 Amps. The control will be initially linear and then at the limiting point will become inactive. At the time of shipping, both P1 and P4 were set to provide linear, 100 Ampere operation. CAUTION: The P2, P3 and P5 controls are for factory adjustment only. The warranty may become invalid if these 3 controls are adjusted.
- 18) The unit can be converted from 120 to 240V 50-60 Hz operation by adjusting the voltage selector card in the rear panel fused voltage selector cable connector assembly.
- 19) If application assistance is required:
- Tel: (613) 226-5772
Fax: (613) 226-2802
Email: info@avtechpulse.com

FIG. 2: FRONT PANEL CONTROLS

FRONT PANEL CONTROLS

- (1) ON-OFF Switch. Applies basic prime power to all stages.
- (2) PRF Control. Varies PRF from 0.1 Hz to 1 kHz as follows:
- | | | | |
|---------|---------|----|---------|
| Range 1 | 0.1 Hz | to | 1 Hz |
| Range 2 | 1 Hz | to | 10 Hz |
| Range 3 | 10 Hz | to | 0.1 kHz |
| Range 4 | 0.1 kHz | to | 1 kHz |
- (3) DELAY Control. Controls the relative delay between the reference output pulse provided at the TRIG output (4) and the -PG output. This delay is variable as follows:
- | | | | |
|---------|--------|----|--------|
| Range 1 | 1 us | to | 10 us |
| Range 2 | 10 us | to | 100 us |
| Range 3 | 100 us | to | 1 ms |
- The TRIG output precedes the main output when the ADVANCE-DELAY switch is in the ADVANCE position and lags when the switch is in the DELAY position.
- (4) TRIG Output. This output is used to trigger the scope time base. The output is a TTL level 100 ns (approx.) pulse capable of driving a fifty Ohm load.
- (5) PW Control. A ten turn control and three-position range switch which varies the output pulse width as follows (when the PW MODE switch is in the INT mode):
- | | | | |
|---------|--------|----|--------|
| Range 1 | 1 us | to | 10 us |
| Range 2 | 10 us | to | 100 us |
| Range 3 | 100 us | to | 1 ms |
- (6) AMP Control. A ten turn control, which varies the output pulse amplitude from 0 to 100 Amps (to $V \leq 50$ Volts).
- (7) INT-EXT-MAN Control. With this toggle switch in the INT position, the PRF of the AV-108 unit is controlled via an internal clock, which in turn is controlled by the PRF control. With the toggle switch in the EXT position, the AVR unit requires a 50 ns (or wider) TTL level pulse applied at the TRIG input in order to trigger the output stages. In addition, in this mode, the scope time base must be triggered by the external trigger source. For single pulse operation, set the INT-EXT-MAN switch in the MAN position.

- (8) SINGLE PULSE. For single pulse manual operation, set the front panel INT-EXT-MAN switch in the MAN position and push the SINGLE PULSE button.
- (9) OVERLOAD PROTECTION:
- a) Model AV-108A-2-C includes a temperature limit circuit, which inhibits triggering of the output module and activates the overload LED if the temperature of the output stage switching elements exceeds +50°C. Triggering of the output module will automatically resume (and the overload LED turn off) after the output modules cool to below +50°C. To reduce heating of the output module, reduce the duty cycle to less than 0.8%.
(see page 8, paragraph 15 also)
- (10) STANDBY-OPERATE. It is recommended that the “Standby/Operate” switch be set to the “Standby” position whenever possible, especially when turning the instrument on or off, when attaching or detaching loads, and when the output is not in use. This switch is part of the “Soft Start” system which insures the total absence of any harmful spurious output signals during the powering up or powering down process. The switch position can be safely changed regardless of the output amplitude setting.

FIG. 3: BACK PANEL CONTROLS

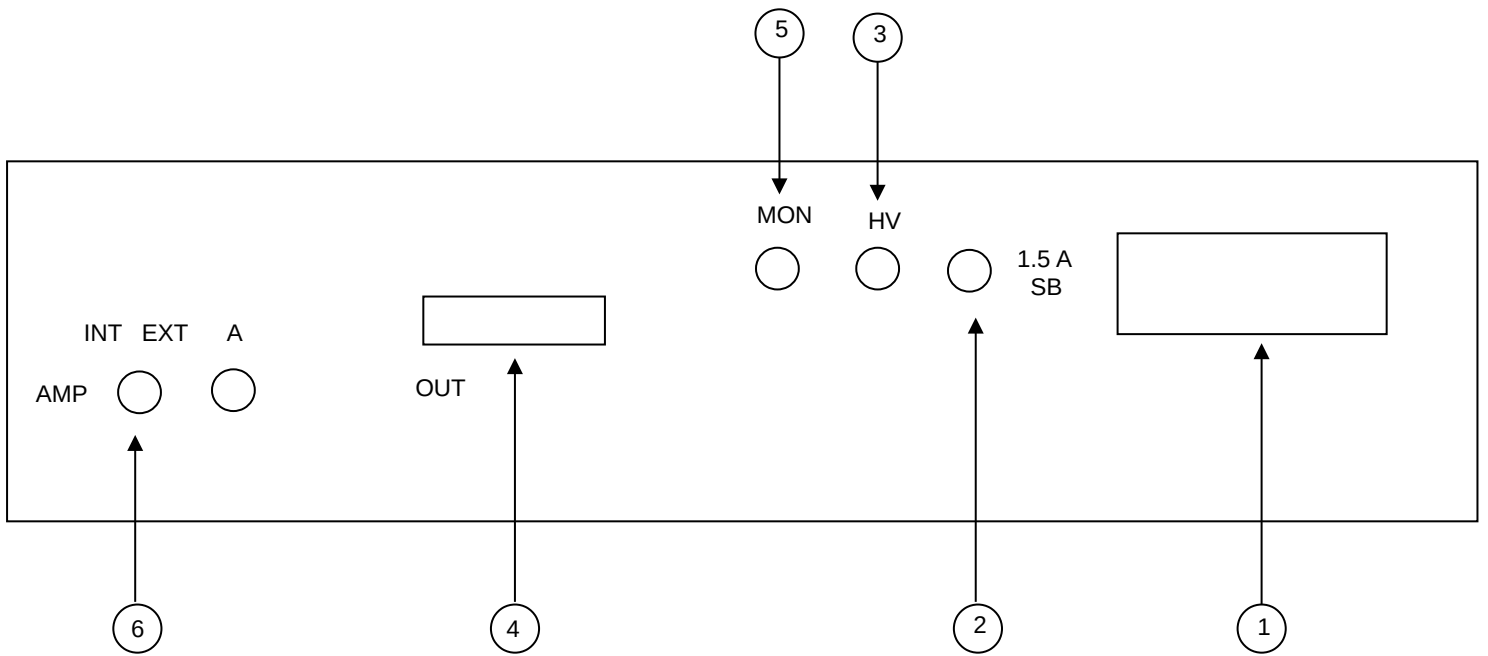

BACK PANEL CONTROLS

- (1) FUSED CONNECTOR, VOLTAGE SELECTOR. The detachable power cord is connected at this point. In addition, the removable cord is adjusted to select the desired input operating voltage. The unit also contains the main power fuse (1.5 A SB).
- (2) 1.5 A SB. Fuse which protects the output stage if the output duty cycle rating is exceeded.
- (3) HV. This BNC connector must be connected to the HV BNC connector on the output module using the supplied 4 foot RG58 cable.
- (4) OUT CONNECTOR. The grey cable from the output module connects to this RS 232 style connector.
- (5) M. This SMA monitor output provides an output voltage (to 50 Ohms or higher) which is linearly proportional to the current flowing through the output terminals (1.0 Volts = 100 Amps). The pulse width (and general wave shape) at M is a replica of the load current, but the monitor may exhibit a spurious DC offset which should be ignored.
- (6) EA. To voltage control the output amplitude, set the switch in the EXT position and apply 0 to +10V to the "A" BNC connector ($R_{IN} \geq 10K$). (option).

START-UP CHECK LIST

- 1) The instruction manual has been studied thoroughly.
- 2) Set the front panel Standby-Operate switch in the Standby position.
- 3) The diode load is connected to the output module. The cathode must be connected to the "OUT" terminal and the anode must be connected to ground. A resistive test load may also be used but the resistor must be less than 0.5 Ohms and non-inductive.
- 4) Insure that the grey cable from the output module is connected to the RS 232 style OUT connector on the mainframe rear panel and the HV BNC connector on the output module is connected to the HV BNC connector on the mainframe rear panel.
- 5) Set the amplitude control on the mainframe fully CCW and set the pulse width and PRF controls at the approximate desired values (while insuring that the duty cycle is less than 0.8%).
- 6) Set the INT-EXT switch on INT.
- 7) Connect the rear panel M output to the scope (1 VOLT/DIV) and connect the TRIG out to the scope time base.
- 8) Turn on the prime power to the mainframe. The scope time base should be triggering and the fan in the output module will be running.
- 9) Set the Standby-Operate switch in the Operate position.
- 10) Gradually clockwise rotate the amplitude control on the mainframe and observe the waveform on the scope. A rectangular pulse should appear on the scope and the amplitude should increase as the amplitude control on the mainframe is rotated clockwise. Any spurious DC component on the monitor output should be ignored. Note that the load current waveforms may also be monitored using a current transformer (such as the Pearson Model 101 or Tektronix Model A6303).
- 11) Observe the pulse width and pulse period on the scope and confirm that the duty cycle does not exceed 0.8%.
- 12) Adjust pulse width, pulse period (i.e. PRF) and amplitude to obtain the desired settings.

13) If additional assistance is required:

Tel: (613) 226-5772

Fax: (613) 226-2802

Email: info@avtechpulse.com

TOP COVER REMOVAL

To remove the top cover, remove the four Phillips screws on the top cover and then slide the cover back and off.

PERFORMANCE CHECK SHEET