



AVTECH ELECTROSYSTEMS LTD.

NANOSECOND WAVEFORM ELECTRONICS
SINCE 1975

P.O. BOX 265
OGDENSBURG, NY
U.S.A. 13669-0265
TEL: (315) 472-5270
FAX: (613) 226-2802

TEL: 1-800-265-6681
FAX: 1-800-561-1970

e-mail: info@avtechpulse.com
<http://www.avtechpulse.com/>

BOX 5120, LCD MERIVALE
OTTAWA, ONTARIO
CANADA K2C 3H4
TEL: (613) 226-5772
FAX: (613) 226-2802

INSTRUCTIONS

MODEL AV-109B-4-B

0 to 100 AMP, 0 to 5 V,
PULSED CONSTANT CURRENT
LASER DIODE DRIVER
WITH IEEE 488.2 AND RS-232 CONTROL

SERIAL NUMBER: _____

WARRANTY

Avtech Electrosystems Ltd. warrants products of its manufacture to be free from defects in material and workmanship under conditions of normal use. If, within one year after delivery to the original owner, and after prepaid return by the original owner, this Avtech product is found to be defective, Avtech shall at its option repair or replace said defective item. This warranty does not apply to units which have been disassembled, modified or subjected to conditions exceeding the applicable specifications or ratings. This warranty is the extent of the obligation assumed by Avtech with respect to this product and no other warranty or guarantee is either expressed or implied.

TECHNICAL SUPPORT

Phone: 613-226-5772 or 1-800-265-6681

Fax: 613-226-2802 or 1-800-561-1970

E-mail: info@avtechpulse.com

World Wide Web: <http://www.avtechpulse.com>

TABLE OF CONTENTS

WARRANTY.....	2
TECHNICAL SUPPORT.....	2
TABLE OF CONTENTS.....	3
INTRODUCTION.....	5
SPECIFICATIONS.....	7
EC DECLARATION OF CONFORMITY.....	8
INSTALLATION.....	9
VISUAL CHECK.....	9
POWER RATINGS.....	9
CONNECTION TO THE POWER SUPPLY.....	9
ENVIRONMENTAL CONDITIONS.....	9
FUSES.....	10
AC FUSE REPLACEMENT.....	10
DC FUSE REPLACEMENT.....	11
FUSE RATINGS.....	11
FRONT PANEL CONTROLS.....	12
MAINFRAME REAR PANEL CONTROLS.....	14
OUTPUT MODULE CONTROLS.....	16
BASIC TEST ARRANGEMENT.....	17
WATER COOLING.....	18
GENERAL INFORMATION.....	19
BASIC PULSE CONTROL.....	19
TRIGGER MODES.....	21
PULSE WIDTH MODES.....	21
GATING MODES.....	21
CURRENT MEASUREMENT.....	22
PROTECTING YOUR INSTRUMENT & LOAD.....	23
PROTECTION CIRCUITRY & AUDIBLE ALARM.....	23
KEEP THE DC POWER SUPPLY VOLTAGE AS LOW AS POSSIBLE.....	23
SELECTING AN APPROPRIATE DC POWER SUPPLY.....	23
POWER-ON CIRCUITRY.....	23
LENZ'S LAW AND INDUCTIVE VOLTAGE SPIKES.....	24
START-UP CHECK-LIST FOR LOCAL CONTROL.....	25
PROGRAMMING YOUR PULSE GENERATOR.....	27

KEY PROGRAMMING COMMANDS.....	27
BASIC INTERNAL OPERATION.....	27
TRIGGERING A SINGLE PULSE.....	27
TRIGGERING FROM AN EXTERNAL TTL PULSE.....	27
ALL PROGRAMMING COMMANDS.....	28
MECHANICAL INFORMATION.....	30
TOP COVER REMOVAL.....	30
RACK MOUNTING.....	30
ELECTROMAGNETIC INTERFERENCE.....	30
MAINTENANCE.....	31
REGULAR MAINTENANCE.....	31
CLEANING.....	31
PERFORMANCE CHECK SHEET.....	32

Manual Reference: /files/server1/officefiles/instructword/av-109/AV-109B-4-B,edition2.sxw.
Last modified February 29, 2024.
Copyright © 2024 Avtech Electrosystems Ltd, All Rights Reserved.

INTRODUCTION

The Model AV-109B-4-B pulse generator is designed for pulsing laser diode and other low impedance loads with rectangular pulses as high as 100 Amperes into load voltages of 0 to 5V, with 7 us rise and fall times.

The current and voltage polarities depend on the model number:

"-P" units: 0 to +100 A amplitude, 0 to +5 V compliance

"-N" units: 0 to -100 A amplitude, 0 to -5 V compliance

"-PN" units: 0 to +100 A amplitude, 0 to +5 V compliance
and
0 to -100 A amplitude, 0 to -5 V compliance

The pulse repetition frequency can vary up to 1 kHz, and pulse widths can vary from 10 ns to 1 second. A DC mode (i.e., infinite pulse width) is provided as well.

The Model AV-109B-4-B pulse generator is a current pulser. The current amplitude is largely independent of the load voltage. The load voltage must not exceed 5V.

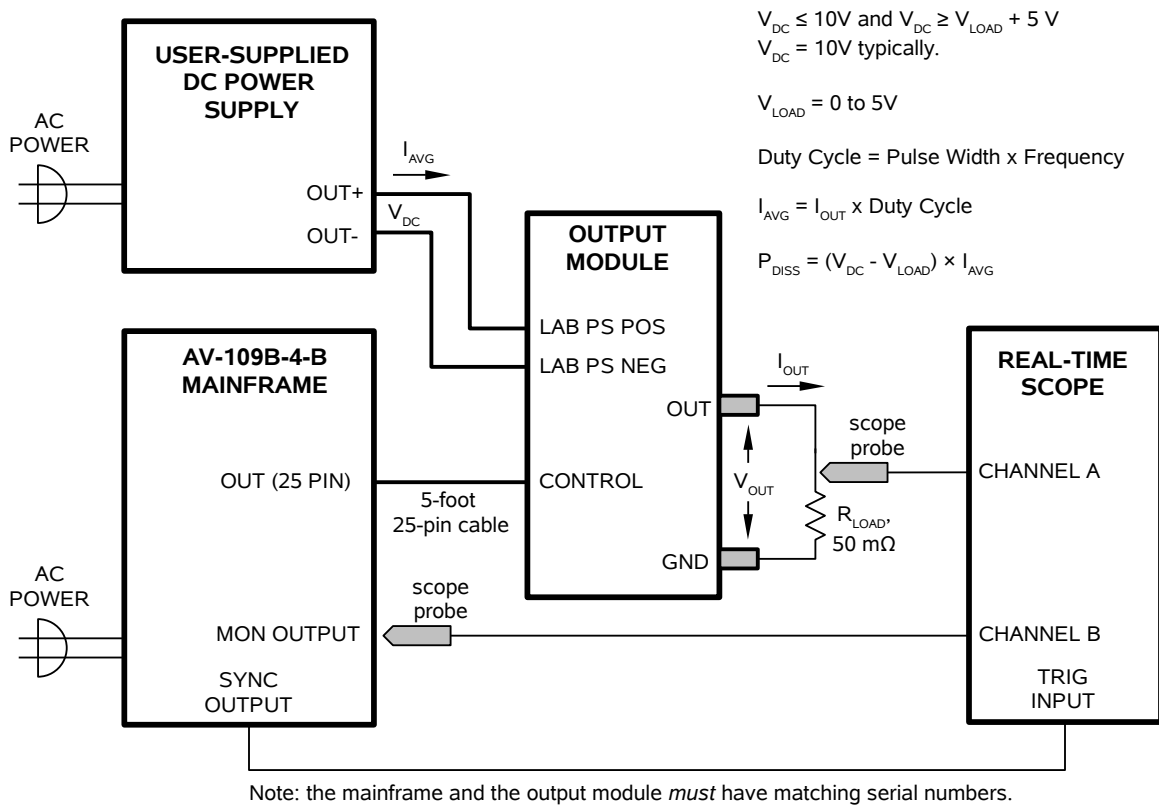

The AV-109B-4-B system consists of an instrument mainframe, an output module which connects to the mainframe via a 5 foot long detachable cable, and a user-supplied high-

current DC lab power supply. The load is connected to two short lengths of heavy copper sheet metal protruding from the module chassis.

The output amplitude is controlled by the AV-109B-4-B, but the user-supplied high current DC lab power supply provides the prime power to the output module (see diagram above). This external power supply magnitude must be set just above the maximum load voltage magnitude, and it must be capable of supplying the average value (i.e. I_{DC}) of the peak current supplied to the load (I_{LOAD}). The maximum average DC current for this instrument is 100 Amps. I_{DC} , I_{LOAD} , pulse width (PW) and pulse period (T) are related as shown in the diagram. See the "Basic Test Arrangement" section for further details.

The AV-109B-4-B includes provision for water-cooling, which should be used when the duty cycle exceeds 8%.

Protective circuits monitor the lab power supply voltage level and the output module temperature and will automatically disable the triggering of the output stage and generate an audible alarm if either the applied voltage or temperature exceed rated values (10V, +50 °C).

A rear-panel BNC monitor output is available which provides an attenuated coincident replica of the main output current pulse. The front-panel display also shows the measured current amplitude.

SPECIFICATIONS

Model ¹ :	AV-109B-4-B
Amplitude ² : Pulse: Optional DC offset ³ : Peak (Pulse + DC offset):	0 to 100 Amps 0 to 10 Amps 100 Amps
Average power out: (maximum)	500 Watts
Load voltage range: (compliance voltage)	0 to 5 Volts
Pulse width:	10 us – 1.0 seconds. A DC mode is also provided.
Max. duty cycle (at peak current)	with water cooling: 100 % without water cooling: 8 %
Rise time, fall time:	7 us
PRF:	Internal trigger: 0.1 Hz to 1 kHz, External trigger: 0 Hz to 1 kHz
Output current regulation:	≤ 5% (for load voltage change from 0 Volts to maximum voltage)
Polarity ⁴ :	Positive or negative or both (specify)
GPIB & RS-232 control ¹ :	Standard on -B units.
LabView drivers:	Check http://www.avtechpulse.com/labview for availability and downloads
Controls:	keypad and adjust knob, and GPIB / RS-232 control
Propagation delay:	≤ 1 us (Ext trig in to pulse out)
Jitter:	± 100 ps ± 0.03% of sync delay (Ext trig in to pulse out)
Trigger required:	External trigger mode: + 5 Volts, 50 to 500 ns (TTL)
Burst mode:	Optional. Add -BR to the model number. See http://www.avtechpulse.com/options/br for details.
Sync delay:	Variable, 0 to ± 1.0 seconds, Sync out to pulse out
Sync output:	+ 3 Volts, 200 ns, will drive 50 Ohm loads
Gate input:	Synchronous or asynchronous, active high or low, switchable. Suppresses triggering when active.
Monitor output:	Provides an attenuated coincident replica of output current pulse
Connectors: Out and Gnd: Trig, Sync, Monitor, Gate: DC Power (if required):	Two parallel copper bars (1.6 x 18 x 40 mm, spaced 24 mm apart), with holes for bolt attachment. (Will mate to optional AV-LZ1-U109 cable). BNC 100 Amp Supercan connectors (included).
Power requirements, AC:	100 - 240 Volts, 50 - 60 Hz
Power requirements, DC ⁵ :	10V, 100A (worst-case)
Possible DC power supplies: Xantrex (www.xantrex.com): Sorensen (www.sorensen.com):	XFR 12-100 DCS 10-100E
Cooling:	Self-contained fan and tap water connection (5 liters/min)
Dimensions: (H x W x D)	Mainframe: 100 mm x 430 mm x 375 mm (3.9" x 17" x 14.8") Output module: 152 mm x 229 mm x 305 mm (6" x 9" x 12")
Chassis material:	Cast aluminum frame and handles, blue vinyl on aluminum cover plates
Mounting:	Any. An optional rack-mount kit is available for the mainframe; see http://www.avtechpulse.com/accessories/rs/ for details.
Temperature range:	+5°C to +40°C

1. -B suffix indicates IEEE-488.2 GPIB and RS-232 control of amplitude, pulse width, PRF and delay. (See <http://www.avtechpulse.com/gpib>).
2. The minimum useful amplitude is 3% of the maximum amplitude.
3. To specify the DC offset option add the suffix -OT to the model number
4. Indicate desired polarity by suffixing the model number with -P or -N (i.e. positive or negative), or -PN for dual polarity.
5. Requires an end-user-supplied external DC power supply. The voltage rating of the power supply must be greater than $V_{LOADmax} + 5V$. The current rating must be greater than the peak output current of the pulser.

EC DECLARATION OF CONFORMITY

We

Avtech Electrosystems Ltd.
P.O. Box 5120, LCD Merivale
Ottawa, Ontario
Canada K2C 3H4

declare that this pulse generator meets the intent of Directive 89/336/EEC for Electromagnetic Compatibility. Compliance pertains to the following specifications as listed in the official Journal of the European Communities:

EN 50081-1 Emission

EN 50082-1 Immunity

and that this pulse generator meets the intent of the Low Voltage Directive 72/23/EEC as amended by 93/68/EEC. Compliance pertains to the following specifications as listed in the official Journal of the European Communities:

EN 61010-1:2001 Safety requirements for electrical equipment for measurement, control, and laboratory use



INSTALLATION

VISUAL CHECK

After unpacking the instrument mainframe and the output module, examine to ensure that they have not been damaged in shipment. Visually inspect all connectors, knobs, liquid crystal displays (LCDs), and the handles. Confirm that a power cord, a GPIB cable, one 25-pin D-subminiature cable, and two instrumentation manuals (this manual and the "Programming Manual for -B Instruments") are with the instrument. If the instrument has been damaged, file a claim immediately with the company that transported the instrument.

POWER RATINGS

This instrument is intended to operate from 100 - 240 V, 50 - 60 Hz.

The maximum power consumption is 57 Watts. Please see the "FUSES" section for information about the appropriate AC and DC fuses.

This instrument is an "Installation Category II" instrument, intended for operation from a normal single-phase supply.

CONNECTION TO THE POWER SUPPLY

An IEC-320 three-pronged recessed male socket is provided on the back panel for AC power connection to the instrument. One end of the detachable power cord that is supplied with the instrument plugs into this socket. The other end of the detachable power cord plugs into the local mains supply. Use only the cable supplied with the instrument. The mains supply must be earthed, and the cable used to connect the instrument to the mains supply must provide an earth connection. (The supplied cable does this.)

ENVIRONMENTAL CONDITIONS

This instrument is intended for use under the following conditions:

1. indoor use;
2. altitude up to 2 000 m;
3. temperature 5 °C to 40 °C;
4. maximum relative humidity 80 % for temperatures up to 31 °C decreasing linearly to 50 % relative humidity at 40 °C;
5. Mains supply voltage fluctuations up to ± 10 % of the nominal voltage;
6. no pollution or only dry, non-conductive pollution.

FUSES

This instrument contains four fuses. All are accessible from the rear-panel. Two protect the AC prime power input, and two protect the internal DC power supplies. The locations of the fuses on the rear panel are shown in the figure below:

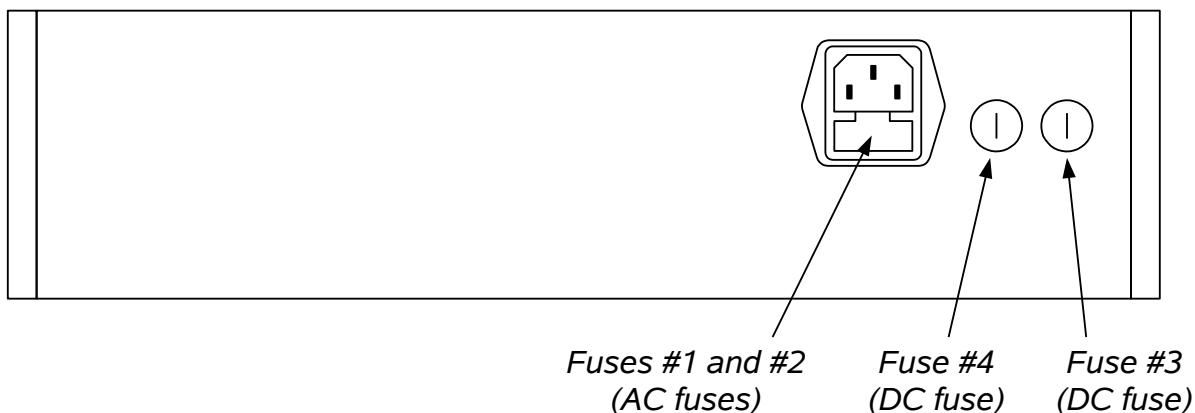

AC FUSE REPLACEMENT

To physically access the AC fuses, the power cord must be detached from the rear panel of the instrument. The fuse drawer may then be extracted using a small flat-head screwdriver, as shown below:

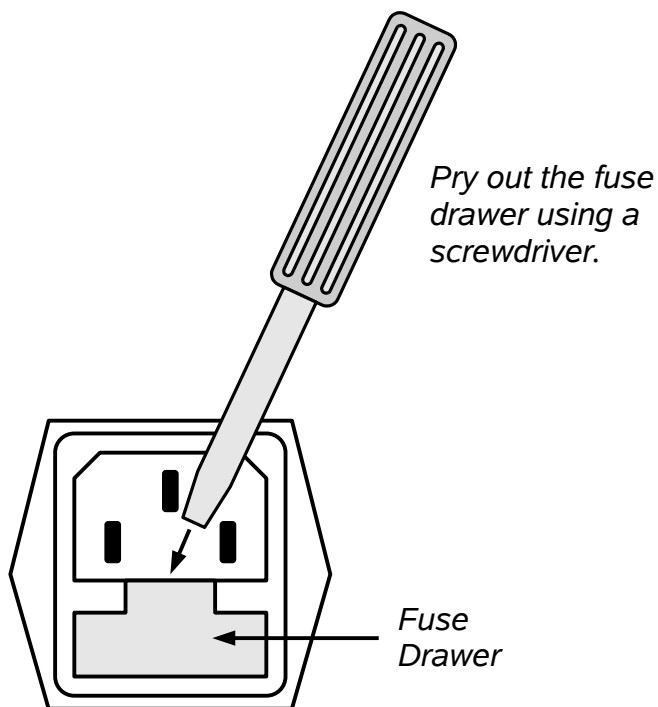

DC FUSE REPLACEMENT

The DC fuses may be replaced by inserting the tip of a flat-head screwdriver into the fuse holder slot, and rotating the slot counter-clockwise. The fuse and its carrier will then pop out.

FUSE RATINGS

The following table lists the required fuses:

Fuses	Nominal Mains Voltage	Rating	Case Size	Manufacturer's Part Number (Wickmann)	Distributor's Part Number (Digi-Key)
#1, #2 (AC)	100-240V	0.5A, 250V, Time-Delay	5×20 mm	1950500000	WK5041-ND
#3 (DC)	N/A	1.6A, 250V, Time-Delay	5×20 mm	1951160000	WK5053-ND
#4 (DC)	N/A	Not used. A spare 1.6A fuse is installed here.			

The fuse manufacturer is Wickmann (<http://www.wickmann.com/>).

Replacement fuses may be easily obtained from Digi-Key (<http://www.digikey.com/>) and other distributors.

FRONT PANEL CONTROLS

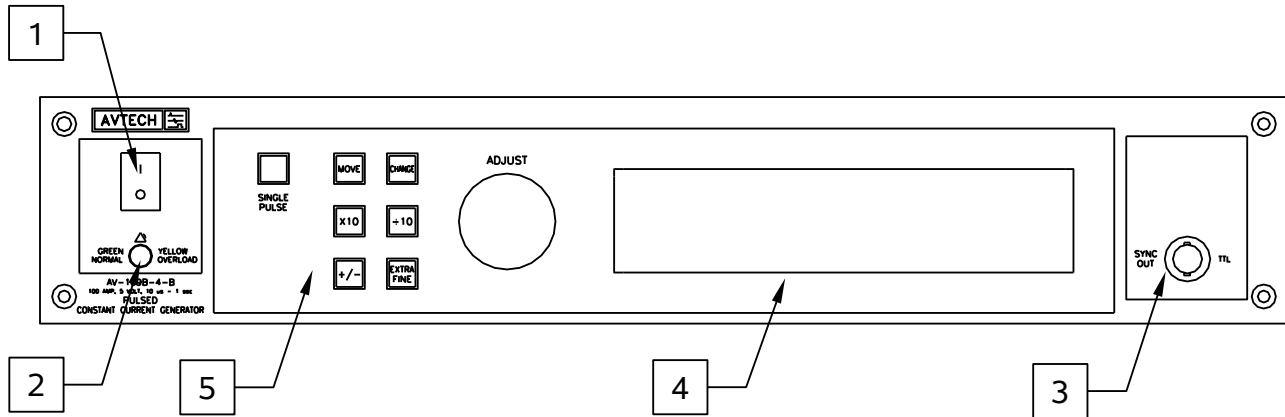

1. POWER Switch. This is the main power switch. When turning the instrument on, there may be a delay of several seconds before the instrument appears to respond.
2. OVERLOAD Indicator. When the instrument is powered, this indicator is normally green, indicating normal operation. If this indicator is yellow, an internal automatic overload protection circuit has been tripped. If the unit is overloaded (by operating at an exceedingly high duty cycle or by operating into a very low impedance), the protective circuit will disable the output of the instrument and turn the indicator light yellow. The light will stay yellow (i.e. output disabled) for about 5 seconds after which the instrument will attempt to re-enable the output (i.e. light green) for about 1 second. If the overload condition persists, the output will be disabled again (i.e. light yellow) for another 5 seconds. If the overload condition has been removed, the instrument will resume normal operation.

This overload indicator may flash yellow briefly at start-up. This is not a cause for concern.

3. SYNC OUT. This connector supplies a SYNC output that can be used to trigger other equipment, particularly oscilloscopes. This signal leads (or lags) the main output by a duration set by the "DELAY" controls and has an approximate amplitude of +3 Volts to $R_L > 50\Omega$ with a pulse width of approximately 100 ns.
4. LIQUID CRYSTAL DISPLAY (LCD). This LCD is used in conjunction with the keypad to change the instrument settings. Normally, the main menu is displayed, which lists the key adjustable parameters and their current values. The "Programming Manual for -B Instruments" describes the menus and submenus in detail.

5. KEYPAD.

Control Name	Function
MOVE	This moves the arrow pointer on the display.
CHANGE	This is used to enter the submenu, or to select the operating mode, pointed to by the arrow pointer.
×10	If one of the adjustable numeric parameters is displayed, this increases the setting by a factor of ten.
÷10	If one of the adjustable numeric parameters is displayed, this decreases the setting by a factor of ten.
+/-	If one of the adjustable numeric parameters is displayed, and this parameter can be both positive or negative, this changes the sign of the parameter.
EXTRA FINE	This changes the step size of the ADJUST knob. In the extra-fine mode, the step size is twenty times finer than in the normal mode. This button switches between the two step sizes.
ADJUST	This large knob adjusts the value of any displayed numeric adjustable values, such as frequency, pulse width, etc. The adjust step size is set by the "EXTRA FINE" button. When the main menu is displayed, this knob can be used to move the arrow pointer.

MAINFRAME REAR PANEL CONTROLS

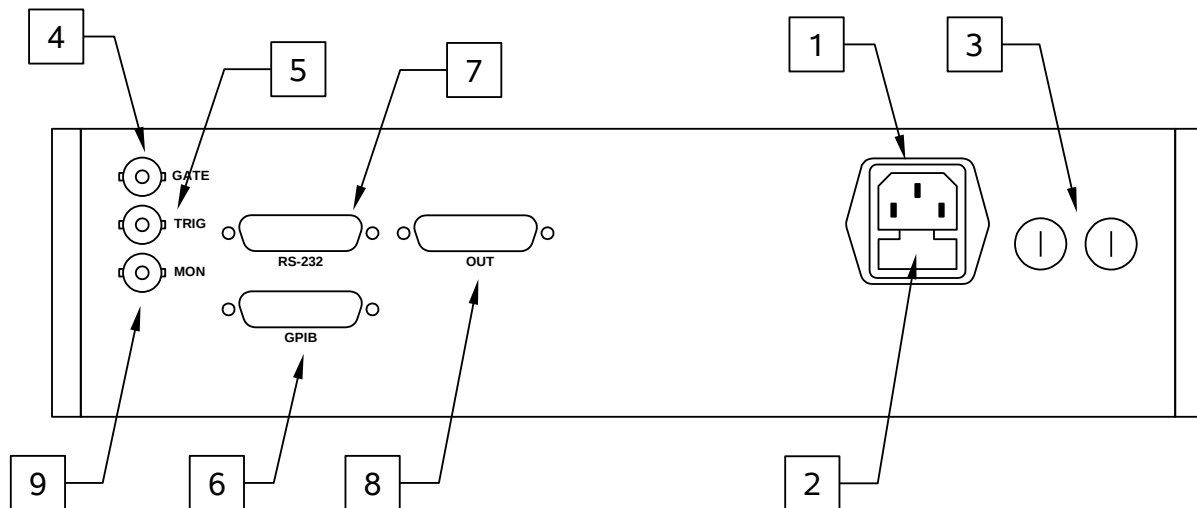

1. AC POWER INPUT. An IEC-320 C14 three-pronged recessed male socket is provided on the back panel for AC power connection to the instrument. One end of the detachable power cord that is supplied with the instrument plugs into this socket.
2. AC FUSE DRAWER. The two fuses that protect the AC input are located in this drawer. Please see the “FUSES” section of this manual for more information.
3. DC FUSES. These two fuses protect the internal DC power supplies. Please see the “FUSES” sections of this manual for more information.
4. GATE. This TTL-level (0 and +5V) logic input can be used to gate the triggering of the instrument. This input can be either active high or active low, depending on the front panel settings or programming commands. (The instrument triggers normally when this input is unconnected). When set to active high mode, this input is pulled-down to ground by a 1 k Ω resistor. When set to active low mode, this input is pulled-up to +5V by a 1 k Ω resistor.
5. TRIG. This TTL-level (0 and +5V) logic input can be used to trigger the instrument, if the instrument is set to triggering externally. The instrument triggers on the rising edge of this input. The input impedance of this input is 1 k Ω . (Depending on the length of cable attached to this input, and the source driving it, it may be desirable to add a coaxial 50 Ohm terminator to this input to provide a proper transmission line termination. The Pasternack (www.pasternack.com) PE6008-50 BNC feed-thru 50 Ohm terminator is suggested for this purpose.)

When triggering externally, the instrument can be set such that the output pulse width tracks the pulse width on this input, or the output pulse width can be set independently.

6. GPIB Connector. A standard GPIB cable can be attached to this connector to allow the instrument to be computer-controlled. See the “Programming Manual for -B

Instruments” for more details on GPIB control.

7. RS-232 Connector. A standard serial cable with a 25-pin male connector can be attached to this connector to allow the instrument to be computer-controlled. See the “Programming Manual for -B Instruments” for more details on RS-232 control.
8. OUT Connector. A 5-foot-long, 25-pin D-subminiature cable is used to connect this output connector to the “Control” connector on the output module. This cable must be installed before power is applied.
9. MON. This is the current monitor output. This output provides a voltage waveform that is proportional to the current waveform on the main output. The monitor relationship is: $V_{MON} = I_{OUT} \times 1V / 50A$, for a load of $> 1 \text{ k}\Omega$. (The monitor output can also drive a 50Ω load, but the output voltage will be reduced by a factor of two. This output is short-circuit protected.)

OUTPUT MODULE CONTROLS

Several ten-turn trimpots are accessible on the -PG output module.

1. P1, Amplitude Scale Control. Rotating this trimpot counter-clockwise will reduce the output current amplitudes proportionally, relative to the set amplitude. For instance, if the output current amplitudes are always 5% too high compared to the front-panel settings, this control can be used to bring the measured and set amplitudes into agreement.
2. P4, Amplitude Limit Control. This control sets the maximum allowed current amplitude. Rotating P4 counter-clockwise will cause the output amplitude to abruptly limit at less than 100A.
3. P2, Untriggered Quiescent Current Control. P2 is for factory-adjustment of the quiescent current level between trigger pulses (i.e. the current offset when not triggered.) This level is set to zero at the time of shipping and should not require further adjusting.

CAUTION: The P2 is for factory adjustment only. The warranty may become invalid if this control is adjusted.

BASIC TEST ARRANGEMENT

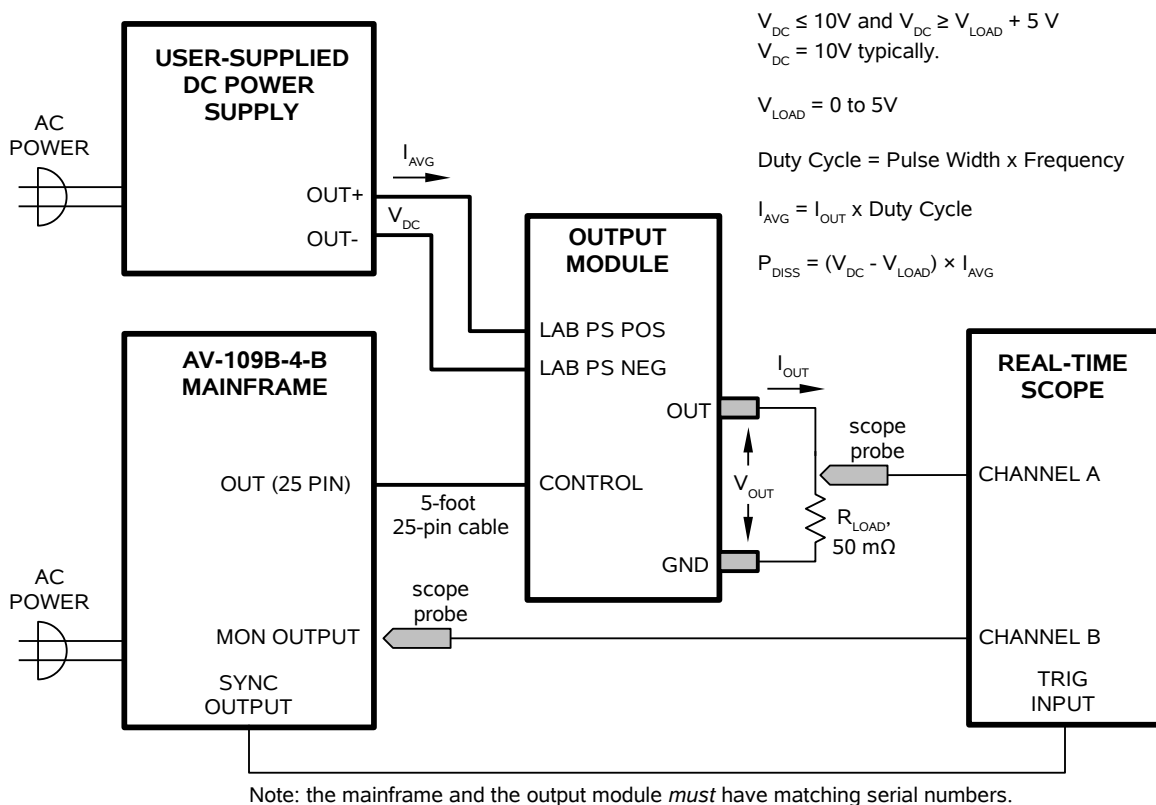

The equipment should be connected in the general fashion shown above. Note that the mainframe and the output module must have matching serial numbers, or the amplitude calibration will be incorrect.

The output module should always be connected to the mainframe BEFORE power is applied. The current monitor will not work properly otherwise.

The user supplied lab power supply attaches to the -PG output module via the red and black SUPERCON connectors that are supplied. The positive terminal of the power supply is to be connected to ground and to the RED SUPERCON connector on the -PG module. The negative terminal on the lab power supply is to be connected to the BLACK SUPERCON connector on the -PG module. This power supply must be capable of supplying 100 Amps of average current.

The output terminals of the pulse generator module consist of short lengths of heavy copper sheet metal protruding from the module chassis.

It is essential that the resistive test load be low-inductance. (Wirewound resistors are not acceptable.) The power dissipated in the resistor is given by

$$P = I^2 \times R \times PW / T$$

where "I" is the current, "R" is the resistance, "PW" is the pulse width, and "T" is the pulse period (1/frequency).

The AV-109B-4-B includes provision for water-cooling, which should be used when the power dissipated in the output module (P_{DISS}) exceeds 40 Watts. P_{DISS} can be calculated using: $P_{DISS} = (V_{DC} - V_{LOAD}) \times I_{AVG}$.

WATER COOLING

The output module has provision for water-cooling. (Thread size is 1/4" NPT.) This cooling is necessary when the power dissipated in the output module (P_{DISS}) exceeds 40 Watts. P_{DISS} can be calculated using: $P_{DISS} = (V_{DC} - V_{LOAD}) \times I_{AVG}$. The water requirement is approximately 15 litres/minute. If water-cooling is not used, or if the water supply fails, the instrument will heat up until the automatic temperature-protection circuitry trips and disables the output until it has cooled.

Note: When connecting the water intake and discharge hoses, it is strongly recommended that teflon plumber's tape be applied to the threaded joints. It is especially important if the mating hardware is stainless steel. Due to the self-adhesion properties of stainless steel, the joint may become virtually impossible to disconnect if the plumber's tape is not used.

GENERAL INFORMATION

BASIC PULSE CONTROL

This instrument can be triggered by its own internal clock or by an external TTL trigger signal. In either case, two output channels respond to the trigger: OUT and SYNC. The OUT channel is the signal that is applied to the load. Its amplitude and pulse width are variable. The SYNC pulse is a fixed-width TTL-level reference pulse used to trigger oscilloscopes or other measurement systems. When the delay is set to a positive value the SYNC pulse precedes the OUT pulse. When the delay is set to a negative value the SYNC pulse follows the OUT pulse.

These pulses are illustrated below, assuming internal triggering and a positive delay:

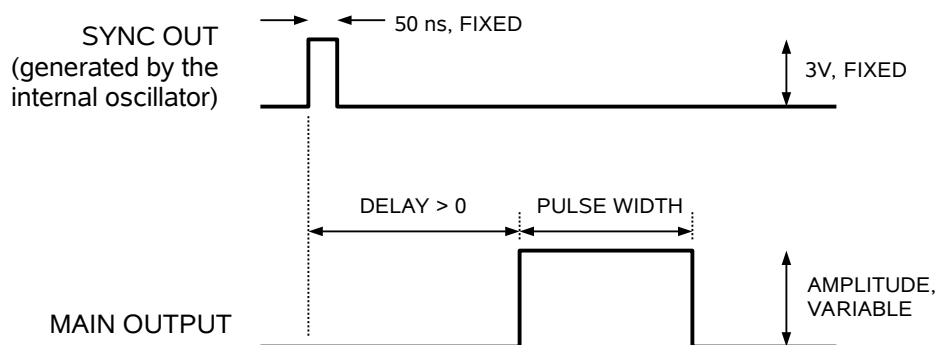

Figure A

If the delay is negative, the order of the SYNC and OUT pulses is reversed:

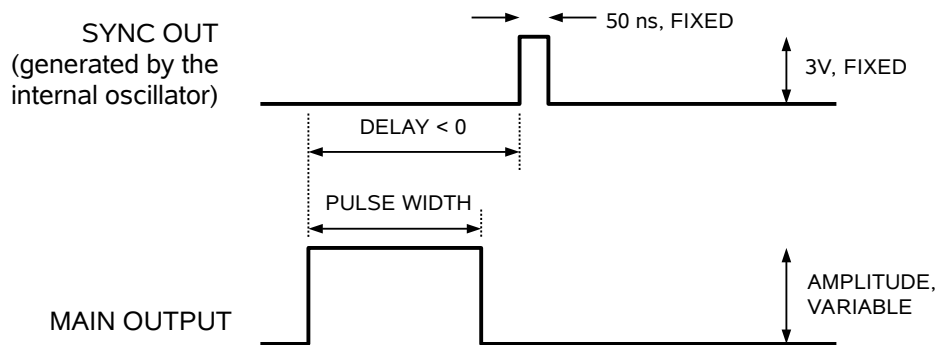

Figure B

The next figure illustrates the relationship between the signal when an external TTL-level trigger is used:

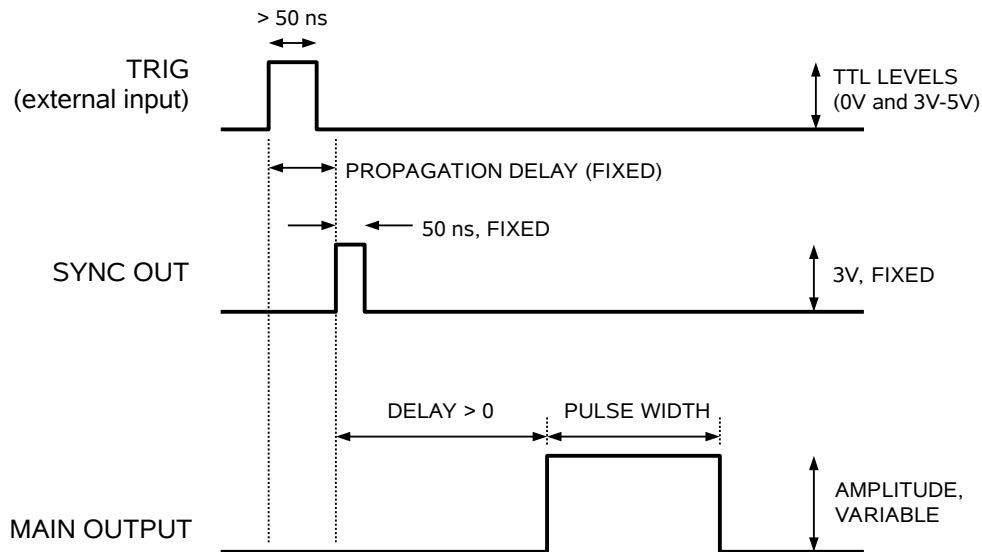

Figure C

As before, if the delay is negative, the order of the SYNC and OUT pulses is reversed.

The last figure illustrates the relationship between the signal when an external TTL-level trigger is used in the $PW_{IN}=PW_{OUT}$ mode. In this case, the output pulse width equals the external trigger's pulse width (approximately), and the delay circuit is bypassed:

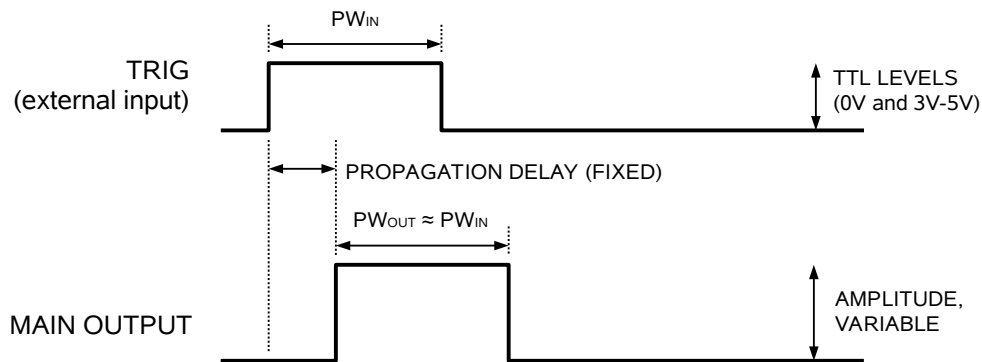

Figure D

The delay, pulse width, and frequency (when in the internal mode), of the OUT pulse can be varied with front panel controls or via the GPIB or RS-232 computer interfaces.

TRIGGER MODES

This instrument has four trigger modes:

- Internal Trigger: the instrument controls the trigger frequency, and generates the clock internally.
- External Trigger: the instrument is triggered by an external TTL-level clock on the back-panel TRIG connector.
- Manual Trigger: the instrument is triggered by the front-panel “SINGLE PULSE” pushbutton.
- Hold Trigger: the instrument is set to not trigger at all.

These modes can be selected using the front panel trigger menu, or by using the appropriate programming commands. (See the “Programming Manual for -B Instruments” for more details.)

PULSE WIDTH MODES

This instrument has two pulse width modes:

- Normal: the instrument controls the output pulse width.
- $PW_{IN}=PW_{OUT}$: the output pulse width equals the pulse width of the trigger signal on the “TRIG” connector. The instrument must be in the external trigger mode.

These modes can be selected using the front panel pulse width menu, or by using the appropriate programming commands. (See the “Programming Manual for -B Instruments” for more details.)

GATING MODES

Triggering can be suppressed by a TTL-level signal on the rear-panel GATE connector. The instrument can be set to stop triggering when this input high or low, using the front-panel gate menu or the appropriate programming commands. This input can also be set to act synchronously or asynchronously. When set to asynchronous mode, the GATE will disable the output immediately. Output pulses may be truncated. When set to synchronous mode, the output will complete the full pulse width if the output is high, and then stop triggering. No pulses are truncated in this mode.

CURRENT MEASUREMENT

Measuring current is more difficult than measuring voltage. There are several basic approaches to measuring pulsed current:

1. If the load is purely resistive, the current may be determined by observing the load voltage with an oscilloscope, and using Ohm's Law:

$$I_{\text{LOAD}} = V_{\text{LOAD}} \div R_{\text{LOAD}}$$

2. If the load is not purely resistive (for instance, a diode load), use a low-resistance, low-inductance, current-sensing resistor connected in series with the load. To minimize inductance, it is usually wise to connect several resistors in parallel. Beware that wirewound resistors usually have far too much inductance to be useful as current-sensing resistors. The current through the load can be determined by measuring the voltage across the sensing resistor, using an oscilloscope.
3. Use the internal current monitor. This feature provides a BNC output connector, whose voltage waveform is proportional to the current waveform on the main output. The current monitor output also measures the amplitude of the most recent pulse, in amperes, and displays it on the front panel LCD. The value can also be read via the computer interface.
4. Use a high-performance current transformer, such as the Pearson 101 (see the Pearson web site at www.pearsonelectronics.com). The voltage output of the current transformer (when terminated into a 50 Ohm load) is proportional to the load current. This approach tends to give the most accurate and undistorted measurements.

PROTECTING YOUR INSTRUMENT & LOAD

PROTECTION CIRCUITRY & AUDIBLE ALARM

This instrument is capable of generating extremely large pulses of current. As a result, the user must exercise caution when operating the instrument.

The output stage is protected by several aggressive protection circuits. These circuits will automatically disable the output, and sound an audible alarm, under the following conditions:

- If the lab power supply voltage exceeds 10V
- If the lab power supply voltage is the incorrect polarity
- If the output switching transistor becomes excessively hot ($\geq 50^{\circ}\text{C}$)

KEEP THE DC POWER SUPPLY VOLTAGE AS LOW AS POSSIBLE

The DC power supply voltage must be kept between 0 and 10V. However, wherever possible, the supply voltage magnitude should be reduced to the lowest level possible – at least 5 Volts above the maximum expected load voltage magnitude. This will reduce the power dissipation in the output switching transistor, prolonging the lifetime of the transistor. For instance, if the load is a diode, and the forward voltage drop is not expected to exceed 3V, then a power supply voltage of 8V could be used, instead of 10V.

SELECTING AN APPROPRIATE DC POWER SUPPLY

The DC power supply must be capable of supplying enough current to the pulser. When operating at low pulse widths (≤ 1 ms), the DC power supply need only supply the *average current* of the output pulse (amplitude \times duty cycle). For example, if you intend to generate 1ms, 100A pulses with 100 Hz pulse repetition frequency (i.e., duty cycle is 10%), the power supply must be rated at $(100\text{A} \times 0.1) = 10\text{A}$.

For wider pulse widths (> 1 ms), the DC power supply must be capable of supplying the full peak current (i.e., up to 100 Amps).

If the power supply has a current limit feature, it is recommended that you use it. This provides extra safety.

POWER-ON CIRCUITRY

This instrument contains power-on protection circuitry, to protect attached loads during instrument turn-on and turn-off. When the instrument is off, the output is shorted to ground through a relay. The output is also shorted to ground when the instrument is on, but the output is set to “OFF”.

LENZ'S LAW AND INDUCTIVE VOLTAGE SPIKES

This instrument is designed to pulse resistive and diode loads and will exhibit a large output spike when used to drive a load with significant inductance (as predicted by LENZ'S LAW). For this reason the load should be connected to the output using low inductance leads (as short as possible and as heavy a gauge as possible).

The voltage developed across an inductance L (in Henries), when the current is changing at a rate given by di_{LOAD}/dt (in Amps/sec), is $V_{SPIKE} = L \times di_{LOAD}/dt$.

Some load inductance is unavoidable. As a result, the output voltage waveform (measured across a resistance) will have some distortion on the leading edge, as shown:

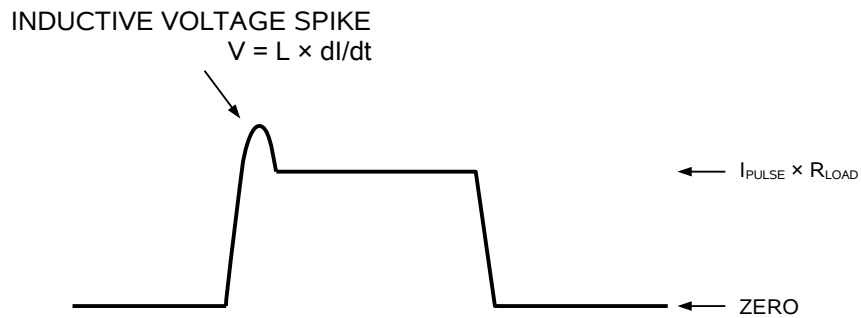

START-UP CHECK-LIST FOR LOCAL CONTROL

- 1) The instruction manual has been studied thoroughly.
- 2) The “Local Control” section of the “Programming Manual for -B Instruments” has been studied thoroughly.
- 3) The -PG output module is connected to the mainframe as shown in the “Basic Test Arrangement” section. (The output module should always be connected to the mainframe BEFORE power is applied. The current monitor will not work properly otherwise. Note that the mainframe and the output module must have matching serial numbers, or the amplitude calibration will be incorrect.)
- 4) If the power dissipated in the output module, $P_{DISS} = (V_{DC} - V_{LOAD}) \times I_{AVG}$, will exceed 40 W, the water-cooling provisions of the output module should be used. (Thread size is 1/4” NPT. Use teflon plumber’s tape, as described in the “Water Cooling” section of this manual.) A flow rate of 15 litres/minutes should be sufficient to cool the module.
- 5) The load is connected to the output module. If the load is a diode, the anode of the load is connected to the OUT terminal. For initial testing, it is recommended that a resistive load be used. Factory tests are conducted using a low-inductance 0.05 Ohm, 500 Watt resistive load.
- 6) The user-supplied lab power supply is connected with the negative terminal connected to the black SUPERCON on the PG module and the positive terminal connected to the red SUPERCON. The power supply potential is set to zero.
- 7) Turn on the prime power to the mainframe. The LCD will briefly display the message, “Nulling Current Monitor ...”, and the main menu will appear.
- 8) The arrow pointer should be pointing at the frequency menu item. If it is not, press the MOVE button until it is.
- 9) Press the CHANGE button. The frequency submenu will appear. Rotate the ADJUST knob until the frequency is set at the desired setting. The arrow pointer should be pointing at the “Internal” choice. If it is not, press MOVE until it is.
- 10) Press CHANGE to return to the main menu.
- 11) Press the MOVE button to move the arrow pointer to the pulse width menu item. Press CHANGE to bring up the pulse width submenu, and rotate the ADJUST knob until the pulse width is set at the desired setting. The arrow pointer should be pointing at the “Normal” choice. If it is not, press MOVE until it is. Press CHANGE to return to the main menu.
- 12) Connect the rear panel M output to the scope (1 VOLT/DIV) and connect the TRIG out to the scope time base. The scope time base should be triggering.

- 13) Connect a scope probe across the resistive test load and apply prime power to the lab power supply (after first ensuring that the output amplitude is set to zero).
- 14) Increase the lab power supply voltage to the desired value ($V_{LOAD} + 5V$).
- 15) Press the MOVE button to move the arrow pointer is pointing at the output item. Press CHANGE to bring up the output submenu. The arrow pointer should be initially be pointing at the "Output Off" choice. Press MOVE so that the arrow pointer is pointing at the "Output On" choice. (The mainframe is now supplying a trigger to the output module.) Press CHANGE to return to the main menu.
- 16) Press the MOVE button to move the arrow pointer to the amplitude menu item. Press CHANGE to bring up the amplitude submenu, and rotate the ADJUST knob until the amplitude is set at the desired setting. Observe the waveforms on the scope and the DC current level on the DC power supply. A rectangular pulse should appear on the scope (for both the load voltage and monitor channels) and the amplitude should increase as the ADJUST knob is rotated. At the same time, the average current supplied by the DC supply will increase.
- 17) If additional assistance is required:

Tel: (613) 226-5772, Fax: (613) 226-2802
Email: info@avtechpulse.com

PROGRAMMING YOUR PULSE GENERATOR

KEY PROGRAMMING COMMANDS

The “Programming Manual for -B Instruments” describes in detail how to connect the pulse generator to your computer, and the programming commands themselves. A large number of commands are available; however, normally you will only need a few of these. Here is a basic sample sequence of commands that might be sent to the instrument after power-up:

BASIC INTERNAL OPERATION

*rst	(resets the instrument)
trigger:source internal	(selects internal triggering)
frequency 10 Hz	(sets the frequency to 10 Hz)
pulse:width 200 us	(sets the pulse width to 200 us)
pulse:delay 30 us	(sets the delay to 30 us)
output on	(turns on the output)
source:current 50 A	(sets the current amplitude to 50 amperes)
measure:amplitude?	(this returns the current amplitude, in amperes, as measured by the monitor circuit)

TRIGGERING A SINGLE PULSE

*rst	(resets the instrument)
trigger:source hold	(turns off all triggering)
pulse:width 200 us	(sets the pulse width to 200 us)
output on	(turns on the output)
source:current 50 A	(sets the current amplitude to 50 amperes)
trigger:source immediate	(generates a single non-repetitive trigger event)
trigger:source hold	(turns off all triggering)
measure:amplitude?	(this returns the current amplitude, in amperes)
output off	(turns off the output)

TRIGGERING FROM AN EXTERNAL TTL PULSE

*rst	(resets the instrument)
trigger:source external	(selects external triggering)
pulse:width 200 us	(sets the pulse width to 200 us)
pulse:delay 1 us	(sets the delay to 1 us)
source:current 50 A	(sets the current amplitude to 50 amperes)
output on	(turns on the output)

These commands will satisfy 90% of your programming needs.

ALL PROGRAMMING COMMANDS

For more advanced programmers, a complete list of the available commands is given below. These commands are described in detail in the “Programming Manual for -B Instruments”. (Note: this manual also includes some commands that are not implemented in this instrument. They can be ignored.)

<u>Keyword</u>	<u>Parameter</u>	<u>Notes</u>
LOCAL		
MEASure:		
:AMPLitude?		[query only]
OUTPut:		
:[STATe]	<boolean value>	
:PROTection		
:TRIPped?		[query only]
REMOTE		
[SOURce]:		
:FREQuency		
[:CW FIXed]	<numeric value>	
[SOURce]:		
:CURRent		
[:LEVel]		
[:IMMediate]		
[:AMPLitude]	<numeric value> EXTernal	
:PROTection		
:TRIPped?		[query only]
[SOURce]:		
:PULSe		
:PERiod	<numeric value>	
:WIDTh	<numeric value>	
:DCYClE	<numeric value>	
:HOLD	WIDTh DCYClE	
:DELay	<numeric value>	
:GATE		
:TYPE	ASync SYnc	
:LEVel	HIgh LOw	
STATUS:		
:OPERation		
:[EVENT]?		[query only, always returns "0"]
:CONDition?		[query only, always returns "0"]
:ENABle	<numeric value>	[implemented but not useful]
:QUEStionable		
:[EVENT]?		[query only, always returns "0"]
:CONDition?		[query only, always returns "0"]
:ENABle	<numeric value>	[implemented but not useful]
SYSTEM:		
:COMMunicate		
:GPIB		
:ADDReSS	<numeric value>	
:SERial		
:CONTRol		
:RTS	ON IBFull RFR	
:[RECEive]		
:BAUD	1200 2400 4800 9600	
:BITS	7 8	
:ECHO	<boolean value>	
:PARity		

	: [TYPE]	EVEN ODD NONE	
	: SBITS	1 2	
:ERRor			
:[NEXT]?			[query only]
:COUNT?			[query only]
:VERSion?			[query only]
TRIGger:			
:SOURce		INTernal EXTernal MANual HOLD IMMEDIATE	
*CLS			[no query form]
*ESE		<numeric value>	
*ESR?			[query only]
*IDN?			[query only]
*OPC			
*SAV		0 1 2 3	[no query form]
*RCL		0 1 2 3	[no query form]
*RST			[no query form]
*SRE		<numeric value>	
*STB?			[query only]
*TST?			[query only]
*WAI			[no query form]

MECHANICAL INFORMATION

TOP COVER REMOVAL

If necessary, the interior of the instrument may be accessed by removing the four Phillips screws on the top panel. With the four screws removed, the top cover may be slid back (and off).

Always disconnect the power cord before opening the instrument.

There are no user-adjustable internal circuits. For repairs other than fuse replacement, please contact Avtech (info@avtechpulse.com) to arrange for the instrument to be returned to the factory for repair.

 Caution: High voltages are present inside the instrument during normal operation. Do not operate the instrument with the cover removed.

RACK MOUNTING

A rack mounting kit is available. The -R5 rack mount kit may be installed after first removing the one Phillips screw on the side panel adjacent to the front handle.

ELECTROMAGNETIC INTERFERENCE

To prevent electromagnetic interference with other equipment, all used outputs should be connected to shielded loads using shielded coaxial cables. Unused outputs should be terminated with shielded coaxial terminators or with shielded coaxial dust caps, to prevent unintentional electromagnetic radiation. All cords and cables should be less than 3m in length.

MAINTENANCE

REGULAR MAINTENANCE

This instrument does not require any regular maintenance.

On occasion, one or more of the four rear-panel fuses may require replacement. All fuses can be accessed from the rear panel. See the “FUSES” section for details.

CLEANING

If desired, the interior of the instrument may be cleaned using compressed air to dislodge any accumulated dust. (See the “TOP COVER REMOVAL” section for instructions on accessing the interior.) No other cleaning is recommended.

PERFORMANCE CHECK SHEET