



AVTECH ELECTROSYSTEMS LTD.

NANOSECOND WAVEFORM ELECTRONICS  
SINCE 1975

P.O. BOX 265  
OGDENSBURG, NY  
U.S.A. 13669-0265

TEL: 888-670-8729 (USA & Canada) or +1-613-686-6675 (Intl)  
FAX: 800-561-1970 (USA & Canada) or +1-613-686-6679 (Intl)

info@avtechpulse.com - <http://www.avtechpulse.com/>

BOX 5120, LCD MERIVALE  
OTTAWA, ONTARIO  
CANADA K2C 3H5

INSTRUCTIONS

MODEL AV-109F-3-B-P

+50 AMP, +5 VOLT

PULSED CONSTANT CURRENT GENERATOR

WITH IEEE 488.2 AND RS-232 CONTROL

SERIAL NUMBER: \_\_\_\_\_

### WARRANTY

Avtech Electrosystems Ltd. warrants products of its manufacture to be free from defects in material and workmanship under conditions of normal use. If, within one year after delivery to the original owner, and after prepaid return by the original owner, this Avtech product is found to be defective, Avtech shall at its option repair or replace said defective item. This warranty does not apply to units which have been disassembled, modified or subjected to conditions exceeding the applicable specifications or ratings. This warranty is the extent of the obligation assumed by Avtech with respect to this product and no other warranty or guarantee is either expressed or implied.

### TECHNICAL SUPPORT

Phone: 888-670-8729 (USA & Canada) or +1-613-686-6675 (International)

Fax: 800-561-1970 (USA & Canada) or +1-613-686-6679 (International)

E-mail: [info@avtechpulse.com](mailto:info@avtechpulse.com)

World Wide Web: <http://www.avtechpulse.com>

## TABLE OF CONTENTS

<b>WARRANTY.....</b>	<b>2</b>
<b>TECHNICAL SUPPORT.....</b>	<b>2</b>
<b>TABLE OF CONTENTS.....</b>	<b>3</b>
<b>INTRODUCTION.....</b>	<b>6</b>
<b>SPECIFICATIONS.....</b>	<b>8</b>
<b>REGULATORY NOTES.....</b>	<b>10</b>
FCC PART 18.....	10
EC DECLARATION OF CONFORMITY.....	10
DIRECTIVE 2011/65/EU (RoHS).....	11
DIRECTIVE 2002/96/EC (WEEE).....	11
FIRMWARE LICENSING.....	12
<b>INSTALLATION.....</b>	<b>13</b>
VISUAL CHECK.....	13
POWER RATINGS.....	13
CONNECTION TO THE POWER SUPPLY.....	13
PROTECTION FROM ELECTRIC SHOCK.....	14
ENVIRONMENTAL CONDITIONS.....	15
<b>FUSES.....</b>	<b>16</b>
AC FUSE REPLACEMENT.....	16
DC FUSE REPLACEMENT.....	17
FUSE RATINGS.....	17
<b>FRONT PANEL CONTROLS.....</b>	<b>18</b>
<b>REAR PANEL CONTROLS.....</b>	<b>20</b>
<b>PULSE GENERATOR TIMING.....</b>	<b>23</b>
BASIC PULSE CONTROL.....	23
TRIGGER MODES.....	25
PULSE WIDTH MODES.....	25
GATING MODES.....	25
<b>CONNECTING TO A POWER SUPPLY.....</b>	<b>26</b>
GROUNDING ISSUES.....	26
USING THE 6 mm CONNECTORS.....	27
SETTING THE DC POWER SUPPLY VOLTAGE LEVEL.....	29
<b>INSTRUMENT AND LOAD PROTECTION.....</b>	<b>30</b>

LENZ'S LAW AND INDUCTIVE VOLTAGE SPIKES.....	30
ATTACHING AND DETACHING LOADS.....	30
ATTACHING AND DETACHING THE POWER SUPPLY.....	30
CHANGING PARAMETERS WHEN A LOAD IS ATTACHED.....	31
QUIESCENT CURRENT.....	31
KIT CONTENTS.....	32
SPECIFICATIONS.....	33
GENERAL INFORMATION.....	33
REPLACEMENT PARTS AND OTHER ACCESSORIES.....	33
<b>CONNECTING TO THE LOAD.....</b>	<b>34</b>
AV-HLZ1-100 CABLE.....	34
AV-HLZAX ADAPTER.....	35
THERMAL NOTES.....	37
<b>CURRENT MONITOR.....</b>	<b>39</b>
<b>ALARMS.....</b>	<b>39</b>
<b>OPERATIONAL CHECK.....</b>	<b>40</b>
<b>PROGRAMMING YOUR PULSE GENERATOR.....</b>	<b>43</b>
KEY PROGRAMMING COMMANDS.....	43
ALL PROGRAMMING COMMANDS.....	43
<b>MECHANICAL INFORMATION.....</b>	<b>46</b>
TOP COVER REMOVAL.....	46
RACK MOUNTING.....	46
ELECTROMAGNETIC INTERFERENCE.....	46
<b>MAINTENANCE.....</b>	<b>47</b>
REGULAR MAINTENANCE.....	47
CLEANING.....	47
<b>WIRING DIAGRAMS.....</b>	<b>48</b>
WIRING OF AC POWER.....	48
PCB 158Q - LOW VOLTAGE POWER SUPPLY, 1/3.....	49
PCB 158Q - LOW VOLTAGE POWER SUPPLY, 2/3.....	50
PCB 158Q - LOW VOLTAGE POWER SUPPLY, 3/3.....	51
PCB 104F - KEYPAD / DISPLAY BOARD, 1/3.....	52
PCB 104F - KEYPAD / DISPLAY BOARD, 2/3.....	53
PCB 104F - KEYPAD / DISPLAY BOARD, 3/3.....	54
PCB 116D - CURRENT MONITOR.....	55

**PCB 94G - ALARM BOARD.....56**  
**PCB 288A - SAFE OPERATING AREA PROTECTION.....57**  
**MAIN WIRING.....58**  
***PERFORMANCE CHECK SHEET.....59***

Manual Reference: /files/server1/officefiles/instructword/av-109/AV-109F-3-B-P,ed3.odt.  
Last modified February 29, 2024.  
Copyright © 2024 Avtech Electrosystems Ltd, All Rights Reserved.

## INTRODUCTION

The Model AV-109F-3-B-P pulsed constant current generator is designed for pulsing laser diode and other low impedance loads with peak currents as high as +50 Amperes, for load voltages in the range of 0 to +5V. The maximum duty cycle is 75%. The pulse width is adjustable from 10 us to 1 second, and the rise and fall times are less than 10 us.

The duty cycle, peak current, and average current are related by  $I_{AVG} = I_{PEAK} \times \text{duty cycle}$ .

The AV-109F-3-B-P requires a user-supplied external DC power supply, capable of supplying the necessary average current to the instrument ( $I_{AVG}$ ). The peak current is supplied by a large capacitor bank inside the pulser. The voltage from the external power supply ( $V_{DC}$ ) must be at least 2 Volts greater than the maximum expected load voltage ( $V_{LOAD}$ ). The maximum difference between  $V_{DC}$  and the maximum  $V_{LOAD}$  must also be controlled to limit the power dissipation in the instrument to 80 Watts:

$$\begin{aligned} V_{DC} - V_{LOAD} &> 2 \text{ Volts} \\ (V_{DC} - V_{LOAD}) \times I_{AVG} &< 80 \text{ Watts} \end{aligned}$$

For example, if the AV-109F-3-B-P is operating at 40% duty cycle and 50 Amps, for an average current of 20A, then  $V_{DC}$  should be between 2 and 4 Volts ( $80W / 20A = 4V$ ) higher than  $V_{LOAD}$ . If  $V_{DC}$  is too high, the output circuits will overheat and protective sensors will disable the output. The maximum permitted value of  $V_{DC}$  is 9V.

The main output connector is a Positronic part number GG8888F1, with four GGFIT00MS/AA high-current contacts. The inner two contacts carry the signal, and the outer two carry the ground lines. The optional AV-HLZ1-100 cable or the AV-HLZAX test load may be plugged into this connector (these items are supplied with the -AK9 accessory kit option). Alternatively, the user may construct their own mating connector, by ordering Positronic ([www.positronic.com](http://www.positronic.com)) part number GG8888M1, with four GGMIT00MS/AA high-current contacts.

All AV-109 units include a monitor output feature that provides an attenuated coincident replica of the main output current pulse ( $V_{MON} = k \times I_{OUT}$ ). The monitor is accurate within  $\pm 3\%$ .

Temperature and voltage sensors protect the output from overheating and excessively high power supply voltages.

All models include an Output On/Off function, as well as power on/off protection circuitry, to protect attached loads.

The pulse repetition frequency is variable for all models from 1 Hz to 1 kHz using the internal oscillator. A delay control and a sync output are provided for oscilloscope triggering purposes. A pushbutton is provided for one-shot operation. The units can

also be triggered externally using a TTL-level pulse. When triggered externally, the output pulse width can be set to follow the input trigger pulse width ( $PW_{OUT} = PW_{IN}$ ), if desired.

The AV-109F-3-B-P includes a complete computer control interface. This provides GPIB and RS-232 computer-control, as well as front panel keypad and adjust knob control of the output pulse parameters. A large backlit LCD displays the output amplitude, frequency, pulse width, and delay. (The DC power supply must be equipped with a GPIB feature, if you wish to remotely control all aspects of the system.) To allow easy integration into automated test systems, the programming command set is based on the SCPI standard, and LabView drivers are available at <http://www.avtechpulse.com/labview>.

This instrument is intended for use in research, development, test and calibration laboratories by qualified personnel.

## SPECIFICATIONS

Model <sup>1</sup> :	AV-109F-3-B
Amplitude <sup>2</sup> :	1.5 to 50 Amps
Pulse:	1.5 to 50 Amps
Optional DC offset <sup>3</sup> :	0.05 to 1 Amp
Peak (Pulse + DC offset):	50 Amps
Average power out: (maximum)	188 Watts
Load voltage range:	0 to 5 Volts
Pulse width (FWHM):	10 $\mu$ s – 1.0 seconds
Maximum duty cycle:	75 %
Rise time, fall time (20%-80%):	10 $\mu$ s
PRF:	Internal trigger: 0.5 Hz to 1 kHz External trigger: 0 Hz to 1 kHz
Output current regulation:	$\leq$ 5% (for load voltage change from 0 Volts to maximum voltage)
Polarity <sup>4</sup> :	Positive or negative (specify)
GPIB & RS-232 control <sup>1</sup> :	Standard on -B units.
LabView drivers:	Check <a href="http://www.avtechpulse.com/labview">http://www.avtechpulse.com/labview</a> for availability and downloads
Ethernet port, for remote control using VXI-11.3, ssh, telnet, & web:	Optional <sup>6</sup> . Recommended as a modern alternative to GPIB / RS-232. See <a href="http://www.avtechpulse.com/options/vxi">http://www.avtechpulse.com/options/vxi</a> for details.
Controls:	Keypad and adjust knob, and GPIB / RS-232 control
Propagation delay:	$\leq$ 1 $\mu$ s (Ext trig in to pulse out)
Jitter:	$\pm$ 100 ps $\pm$ 0.03% of sync delay (Ext trig in to pulse out)
Trigger modes:	Internal trigger, external trigger (TTL level pulse, > 10 ns, 1 k $\Omega$ input impedance), front-panel "Single Pulse" pushbutton, or single pulse trigger via computer command. In the external trigger mode, the pulse width may be set by the instrument, or it may be set to track the input pulse width.
Variable delay:	Sync to main out: 0 to 1.0 seconds, for all trigger modes (including external trigger).
Sync output:	> +3 Volts, > 50 ns, will drive 50 Ohm loads
Gate input:	Synchronous or asynchronous, active high or low, switchable. Suppresses triggering when active.
Settings resolution:	The resolution of the timing parameters (pulse width, delay, period) varies, but is always better than 0.15% of ( set value  + 20 ns). The amplitude resolution is < 0.1% of the maximum amplitude.
Settings accuracy:	Typically $\pm$ 3% (plus $\pm$ 1.5% of maximum amplitude/offset, or $\pm$ 3 ns) after 10 minute warmup, subject to a minimum timing uncertainty of $1.5 \times$ (Rated rise time + Rated fall time). For high-accuracy applications requiring traceable calibration, verify the output parameters with a calibrated oscilloscope.
Monitor output:	Provides an attenuated coincident replica of output current pulse
Connectors: DC Power (+ and -):	6 mm plug / 4 mm sockets <sup>7</sup> (+ red, - black)
OUT & GND:	Positronic ( <a href="http://www.positronic.com">www.positronic.com</a> ) female connector <sup>9</sup>
Trig, Sync, Monitor, Gate:	BNC
Power requirements, AC:	100 - 240 V, 50 - 60 Hz
Power requirements, DC <sup>5</sup> :	7V, 50A (worst-case)
Possible DC power supplies:	
Xantrex ( <a href="http://www.xantrex.com">www.xantrex.com</a> ):	XHR 20-50
Sorensen ( <a href="http://www.sorensen.com">www.sorensen.com</a> ):	LHP 20-50
Kepco ( <a href="http://www.kepco.com">www.kepco.com</a> ):	JQE 15-50M
Agilent ( <a href="http://www.agilent.com">www.agilent.com</a> ):	HP 6032A
Maximum internal dissipation, $(V_{DC} - V_{LOAD}) \times I_{PULSE} \times$ duty cycle:	80 Watts. $V_{DC}$ must be set appropriately to respect this limit.
Cooling:	Self-contained fan
Optional recommended accessory kit for DC input cabling:	-AK3 option: Provides two 1m cables (1 red, 1 black) with 6mm safety sockets <sup>8</sup> , and two 6mm safety plug to M6 stud adapters <sup>7</sup> (1 red, 1 black)
Optional recommended accessory kit for output cabling:	-AK9 option: Provides one AV-HLZ1-100 cable (100 cm length, $Z_0 = 1$ Ohm. This transmission line cable matches low impedance loads without degrading the signal rise and fall times significantly. The chassis end of the cable is terminated with a Positronic male connector <sup>10</sup> and the load end is terminated with a Positronic female connector <sup>9</sup> ). Also provides an adapter which mates to the end of this cable, and provides the output on two identical contact posts into which M6x1 threaded screws may be screwed to a maximum depth of 15 mm.
Dimensions (H x W x D):	138 mm x 430 mm x 425 mm (5.5" x 17" x 16.8")
Chassis material:	Anodized aluminum, with blue plastic trim
Rack-mount kit:	Add the suffix -R6 to the model number to include 19" rack mount kit.
Temperature range:	+5°C to +40°C

1) -B suffix indicates IEEE-488.2 GPIB and RS-232 control of amplitude, pulse width, PRF and delay. (See <http://www.avtechpulse.com/gpib>).

2) The minimum useful amplitude is 3% of the maximum amplitude.

3) To specify the DC offset option add the suffix -OT to the model number

4) Indicate desired polarity by suffixing the model number with -P or -N (i.e. positive or negative), or -PN for dual polarity.

5) AV-109B models rated at 50 Amps or more require an end-user-supplied external DC power supply. The voltage rating of the power supply must be greater than  $V_{LOADmax} + 5V$ . The current rating must be greater than the peak output current of the pulser.

6) Add the suffix -VXI to the model number to specify the Ethernet port.



- 7) Multi-Contact (<http://www.multi-contact.com> or <http://www.multi-contact-usa.com>) ID/S6AR-N-B4S series, or similar.
- 8) Multi-Contact (<http://www.multi-contact.com> or <http://www.multi-contact-usa.com>) SLK616-AR/BGG series, or similar.
- 9) Positronic part number GG8888F1, with four GGFIT00MS/AA high-current contacts. The inner two contacts carry the signal, and the outer two carry the ground lines.
- 10) Positronic part number GG8888M1, with four GGMIT00MS/AA high-current contacts. The inner two contacts carry the signal, and the outer two carry the ground lines.

## REGULATORY NOTES

### FCC PART 18

This device complies with part 18 of the FCC rules for non-consumer industrial, scientific and medical (ISM) equipment.

This instrument is enclosed in a rugged metal chassis and uses a filtered power entry module (where applicable). The main output signal is provided on a shielded connector that is intended to be used with shielded coaxial cabling and a shielded load. Under these conditions, the interference potential of this instrument is low.

If interference is observed, check that appropriate well-shielded cabling is used on the output connectors. Contact Avtech ([info@avtechpulse.com](mailto:info@avtechpulse.com)) for advice if you are unsure of the most appropriate cabling. Also, check that your load is adequately shielded. It may be necessary to enclose the load in a metal enclosure.

If any of the connectors on the instrument are unused, they should be covered with shielded metal "dust caps" to reduce the interference potential.

This instrument does not normally require regular maintenance to minimize interference potential. However, if loose hardware or connectors are noted, they should be tightened. Contact Avtech ([info@avtechpulse.com](mailto:info@avtechpulse.com)) if you require assistance.

### EC DECLARATION OF CONFORMITY



We                    Avtech Electrosystems Ltd.  
                          P.O. Box 5120, LCD Merivale  
                          Ottawa, Ontario  
                          Canada K2C 3H5

declare that this pulse generator meets the intent of Directive 2004/108/EG for Electromagnetic Compatibility. Compliance pertains to the following specifications as listed in the official Journal of the European Communities:

EN 50081-1 Emission

EN 50082-1 Immunity

and that this pulse generator meets the intent of the Low Voltage Directive 2006/95/EC. Compliance pertains to the following specifications as listed in the official Journal of the European Communities:

EN 61010-1:2001 Safety requirements for electrical equipment for measurement, control, and laboratory use

DIRECTIVE 2011/65/EU (RoHS)

We Avtech Electrosystems Ltd.  
P.O. Box 5120, LCD Merivale  
Ottawa, Ontario  
Canada K2C 3H5

declare that, to the best of our knowledge, all electrical and electronic equipment (EEE) sold by the company are in compliance with Directive 2011/65/EU of the European Parliament and of the Council of 8 June 2011 on the restriction of the use of certain hazardous substances in electrical and electronic equipment (also known as “RoHS Recast”). In addition, this declaration of conformity is issued under the sole responsibility of Avtech Electrosystems Ltd. Specifically, products manufactured do not contain the substances listed in the table below in concentrations greater than the listed maximum value.

<i>Material/Substance</i>	<i>Threshold level</i>
Lead (Pb)	< 1000 ppm (0.1% by mass)
Mercury (Hg)	< 1000 ppm (0.1% by mass)
Hexavalent Chromium (Cr6+)	< 1000 ppm (0.1% by mass)
Polybrominated Biphenyls (PBB)	< 1000 ppm (0.1% by mass)
Polybrominated Diphenyl ethers (PBDE)	< 1000 ppm (0.1% by mass)
Cadmium (Cd)	< 100 ppm (0.01% by mass)

DIRECTIVE 2002/96/EC (WEEE)

European customers who have purchased this equipment directly from Avtech will have completed a “WEEE Responsibility Agreement” form, accepting responsibility for WEEE compliance (as mandated in Directive 2002/96/EC of the European Union and local laws) on behalf of the customer, as provided for under Article 9 of Directive 2002/96/EC.

Customers who have purchased Avtech equipment through local representatives should consult with the representative to determine who has responsibility for WEEE

compliance. Normally, such responsibilities will lie with the representative, unless other arrangements (under Article 9) have been made.

Requirements for WEEE compliance may include registration of products with local governments, reporting of recycling activities to local governments, and financing of recycling activities.

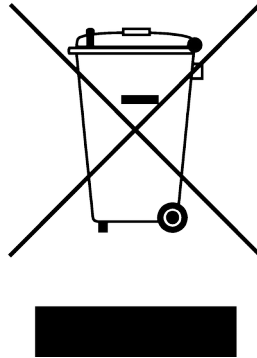

### FIRMWARE LICENSING

Instruments with firmware versions 5.00 or higher use open-source software internally. Some of this software requires that the source code be made available to the user as a condition of its licensing. This source code is available upon request (contact [info@avtechpulse.com](mailto:info@avtechpulse.com)).

Earlier firmware versions do not contain any open source software.

## INSTALLATION

### VISUAL CHECK

After unpacking the instrument, examine to ensure that it has not been damaged in shipment. Visually inspect all connectors, knobs, liquid crystal displays (LCDs), and the handles. If the instrument has been damaged, file a claim immediately with the company that transported the instrument.

Confirm that the following items are present:

- The mainframe (i.e., the main instrument chassis)
- A power cord
- A GPIB cable
- Two instrumentation manuals (this manual and the “Programming Manual for -B Instruments”) are with the instrument.

If the -AK3 option has been specified, the following should also be present:

- Two 1 m cables (one red, one black) with 6 mm safety sockets
- Two 6 mm safety plug to M6 stud adapters (one red, one black)

If the -AK9 option has been specified, the following should also be present:

- One AV-HLZ1-100 rugged connectorized transmission line, 100 cm long
- One AV-HLZAX adapter

### POWER RATINGS

This instrument is intended to operate from 100 - 240 V, 50 - 60 Hz.

The maximum power consumption is 57 Watts. Please see the “FUSES” section for information about the appropriate AC and DC fuses.

This instrument is an “Installation Category II” instrument, intended for operation from a normal single-phase supply.

### CONNECTION TO THE POWER SUPPLY

An IEC-320 three-pronged recessed male socket is provided on the back panel for AC power connection to the instrument. One end of the detachable power cord that is supplied with the instrument plugs into this socket. The other end of the detachable power cord plugs into the local mains supply. Use only the cable supplied with the instrument. The mains supply must be earthed, and the cord used to connect the

instrument to the mains supply must provide an earth connection. (The supplied cord does this.)

 Warning: Failure to use a grounded outlet may result in injury or death due to electric shock. This product uses a power cord with a ground connection. It must be connected to a properly grounded outlet. The instrument chassis is connected to the ground wire in the power cord.

The table below describes the power cord that is normally supplied with this instrument, depending on the destination region:

Destination Region	Description	Option	Manufacturer	Part Number
United Kingdom, Hong Kong, Singapore, Malaysia	BS 1363, 230V, 50 Hz	-AC00	Qualtek	370001-E01
Australia, New Zealand	AS 3112:2000, 230-240V, 50 Hz	-AC01	Qualtek	374003-A01
Continental Europe, Korea, Indonesia, Russia	European CEE 7/7 "Schuko" 230V, 50 Hz	-AC02	Qualtek	364002-D01
North America, Taiwan	NEMA 5-15, 120V, 60 Hz	-AC03	Qualtek	312007-01
Switzerland	SEV 1011, 230V, 50 Hz	-AC06	Qualtek	378001-E01
South Africa, India	SABS 164-1, 220-250V, 50 Hz	-AC17	Volex	2131H 10 C3
Japan	JIS 8303, 100V, 50-60 Hz	-AC18	Qualtek	397002-01
Israel	SI 32, 220V, 50 Hz	-AC19	Qualtek	398001-01
China	GB 1002-1, 220V, 50 Hz	-AC22	Volex	2137H 10 C3

## PROTECTION FROM ELECTRIC SHOCK

 Operators of this instrument must be protected from electric shock at all times. The owner must ensure that operators are prevented access and/or are insulated from every connection point. In some cases, connections must be exposed to potential human contact. Operators must be trained to protect themselves from the risk of electric shock. This instrument is intended for use by qualified personnel who recognize shock hazards and are familiar with safety precautions required to avoid possibly injury. In particular, operators should:

1. Keep exposed high-voltage wiring to an absolute minimum.

2. Wherever possible, use shielded connectors and cabling.
3. Connect and disconnect loads and cables only when the instrument is turned off.
4. Keep in mind that all cables, connectors, oscilloscope probes, and loads must have an appropriate voltage rating.
5. Do not attempt any repairs on the instrument, beyond the fuse replacement procedures described in this manual. Contact Avtech technical support (see page 2 for contact information) if the instrument requires servicing. Service is to be performed solely by qualified service personnel.

### ENVIRONMENTAL CONDITIONS

This instrument is intended for use under the following conditions:

1. indoor use;
2. altitude up to 2 000 m;
3. temperature 5 °C to 40 °C;
4. maximum relative humidity 80 % for temperatures up to 31 °C decreasing linearly to 50 % relative humidity at 40 °C;
5. Mains supply voltage fluctuations up to  $\pm 10$  % of the nominal voltage;
6. no pollution or only dry, non-conductive pollution.

## FUSES

This instrument contains four fuses. All are accessible from the rear-panel. Two protect the AC prime power input, and two protect the internal DC power supplies. The locations of the fuses on the rear panel are shown in the figure below:

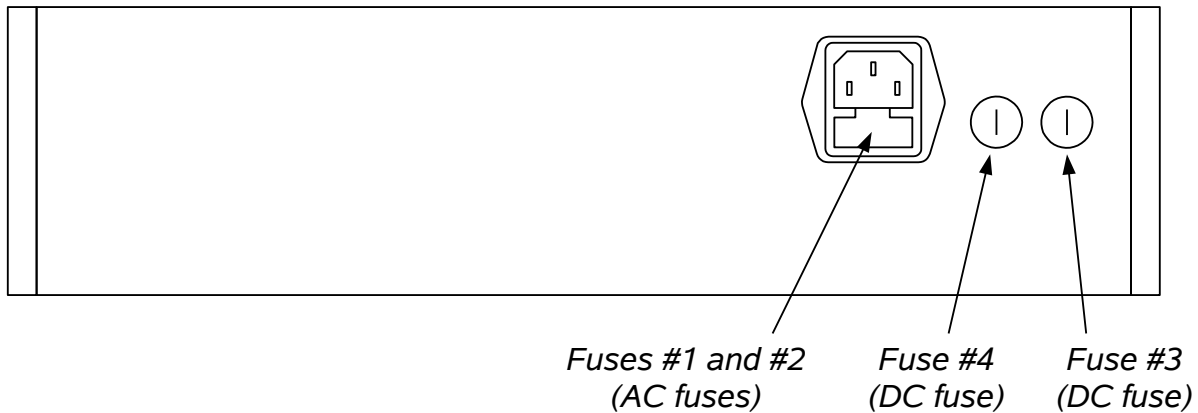

### AC FUSE REPLACEMENT

To physically access the AC fuses, the power cord must be detached from the rear panel of the instrument. The fuse drawer may then be extracted using a small flat-head screwdriver, as shown below:

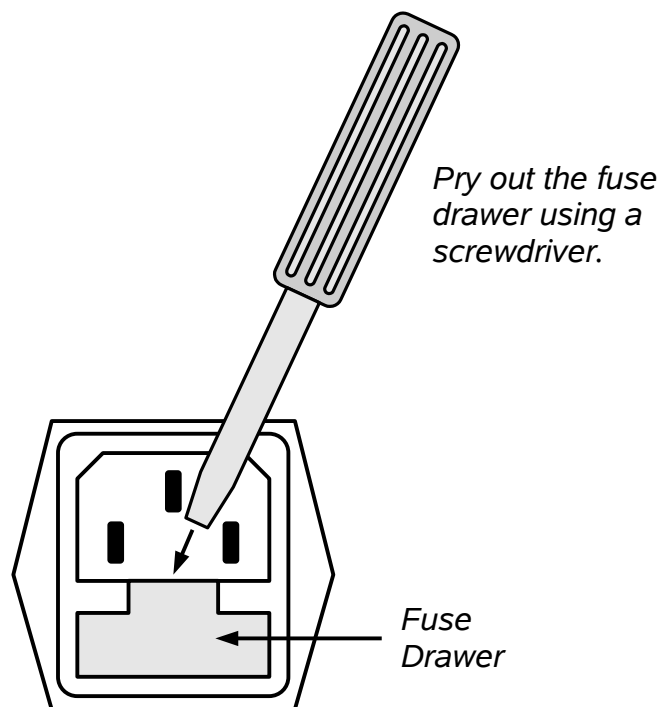



## DC FUSE REPLACEMENT

The DC fuses may be replaced by inserting the tip of a flat-head screwdriver into the fuse holder slot, and rotating the slot counter-clockwise. The fuse and its carrier will then pop out.

## FUSE RATINGS

The following table lists the required fuses:

Fuses	Nominal Mains Voltage	Rating	Case Size	Recommended Replacement Part	
				Littelfuse Part Number	Digi-Key Stock Number
#1, #2 (AC)	100-240V	0.5A, 250V, Time-Delay	5×20 mm	0218.500HXP	F2416-ND
#3 (DC)	N/A	1.6A, 250V, Time-Delay	5×20 mm	021801.6HXP	F2424-ND
#4 (DC)	N/A	Not used. A spare 1.6A fuse is installed here.			

The recommended fuse manufacturer is Littelfuse (<http://www.littelfuse.com>).

Replacement fuses may be easily obtained from Digi-Key (<http://www.digikey.com>) and other distributors.

## FRONT PANEL CONTROLS

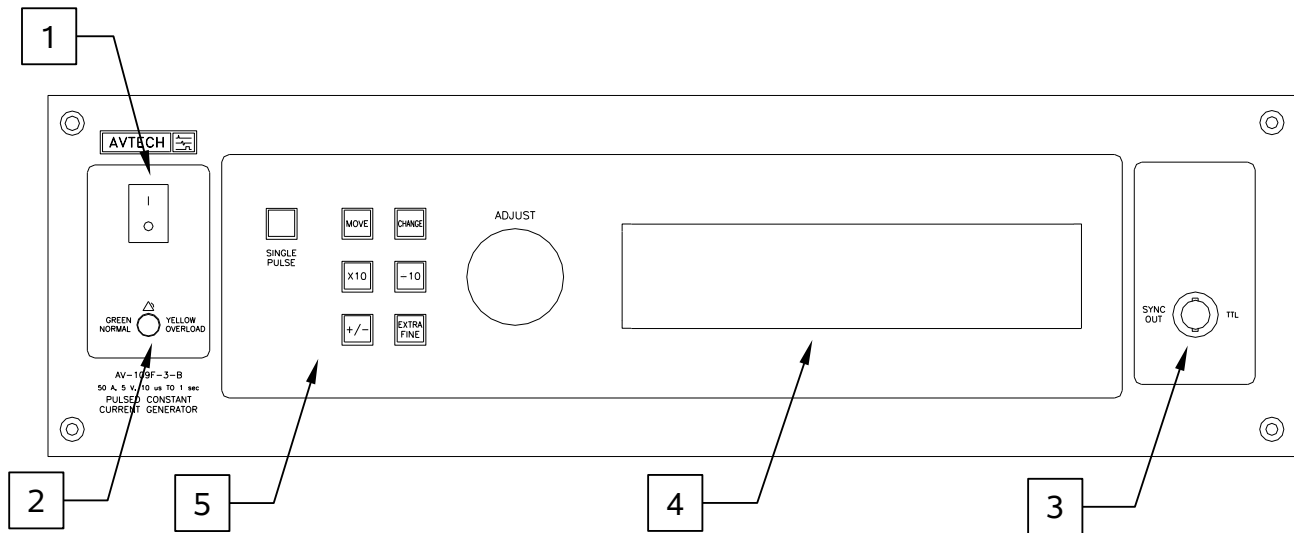

1. **POWER Switch.** This is the main power switch. When turning the instrument on, there is normally a delay of 10 seconds before anything is shown on the main display, as the internal operating system boots up.

If the main menu does not appear after 30 seconds, turn off the instrument and leave it off for at least 60 seconds before applying power again.

2. **OVERLOAD Indicator.** When the instrument is powered, this indicator is normally green, indicating normal operation. If this indicator is yellow, an internal automatic overload protection circuit has been tripped. If the unit is overloaded (by operating at an exceedingly high duty cycle or by operating into a very low impedance), the protective circuit will disable the output of the instrument and turn the indicator light yellow. The light will stay yellow (i.e. output disabled) for about 5 seconds after which the instrument will attempt to re-enable the output (i.e. light green) for about 1 second. If the overload condition persists, the output will be disabled again (i.e. light yellow) for another 5 seconds. If the overload condition has been removed, the instrument will resume normal operation.

This overload indicator may flash yellow briefly at start-up. This is not a cause for concern.

Note that the output stage will safely withstand a short-circuited load condition.

3. **SYNC OUT.** This connector supplies a SYNC output that can be used to trigger other equipment, particularly oscilloscopes. This signal leads (or lags) the main output by a duration set by the "DELAY" controls and has an approximate amplitude of +3 Volts to  $R_L > 50\Omega$  with a pulse width of approximately 100 ns.
4. **LIQUID CRYSTAL DISPLAY (LCD).** This LCD is used in conjunction with the keypad to change the instrument settings. Normally, the main menu is displayed,

which lists the key adjustable parameters and their current values. The “Programming Manual for -B Instruments” describes the menus and submenus in detail.

## 5. KEYPAD.

Control Name	Function
MOVE	This moves the arrow pointer on the display.
CHANGE	This is used to enter the submenu, or to select the operating mode, pointed to by the arrow pointer.
×10	If one of the adjustable numeric parameters is displayed, this increases the setting by a factor of ten.
÷10	If one of the adjustable numeric parameters is displayed, this decreases the setting by a factor of ten.
+/-	If one of the adjustable numeric parameters is displayed, and this parameter can be both positive or negative, this changes the sign of the parameter.
EXTRA FINE	This changes the step size of the ADJUST knob. In the extra-fine mode, the step size is twenty times finer than in the normal mode. This button switches between the two step sizes.
ADJUST	This large knob adjusts the value of any displayed numeric adjustable values, such as frequency, pulse width, etc. The adjust step size is set by the "EXTRA FINE" button.  When the main menu is displayed, this knob can be used to move the arrow pointer.

## REAR PANEL CONTROLS

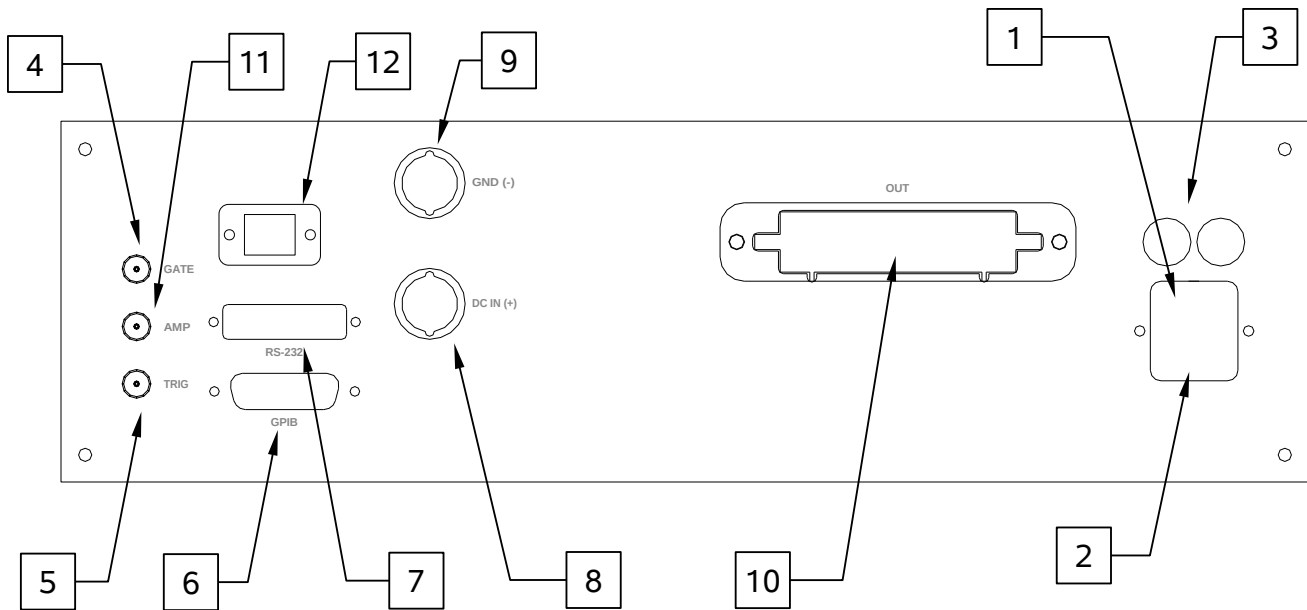

1. AC POWER INPUT. An IEC-320 C14 three-pronged recessed male socket is provided on the back panel for AC power connection to the instrument. One end of the detachable power cord that is supplied with the instrument plugs into this socket.
2. AC FUSE DRAWER. The two fuses that protect the AC input are located in this drawer. Please see the “FUSES” section of this manual for more information.
3. DC FUSES. These two fuses protect the internal DC power supplies. Please see the “FUSES” sections of this manual for more information.
4. GATE. This TTL-level (0 and +5V) logic input can be used to gate the triggering of the instrument. This input can be either active high or active low, depending on the front panel settings or programming commands. (The instrument triggers normally when this input is unconnected). When set to active high mode, this input is pulled-down to ground by a 1 k $\Omega$  resistor. When set to active low mode, this input is pulled-up to +5V by a 1 k $\Omega$  resistor.
5. TRIG. This TTL-level (0 and +5V) logic input can be used to trigger the instrument, if the instrument is set to triggering externally. The instrument triggers on the rising edge of this input. The input impedance of this input is 1 k $\Omega$ . (Depending on the length of cable attached to this input, and the source driving it, it may be desirable to add a coaxial 50 Ohm terminator to this input to provide a proper transmission line termination. The Pasternack ([www.pasternack.com](http://www.pasternack.com)) PE6008-50 BNC feed-thru 50 Ohm terminator is suggested for this purpose.)

When triggering externally, the instrument can be set such that the output pulse

width tracks the pulse width on this input, or the output pulse width can be set independently.

 Do not exceed a repetition rate of 1 kHz when triggering externally. Excessive repetition rates may cause over-heating internally, and possible damage the instrument.

6.  GPIB Connector. A standard GPIB cable can be attached to this connector to allow the instrument to be computer-controlled. See the “Programming Manual for -B Instruments” for more details on GPIB control.
7.  RS-232 Connector. A standard serial cable with a 25-pin male connector can be attached to this connector to allow the instrument to be computer-controlled. A user name (“admin”) and a password (“default”, as shipped from the factory) are required when logging into a serial terminal session. The internal controller attempts to auto-sense the parity setting. It may be necessary to send a few return characters before attempting a login in order to provide enough data to allow this auto-sensing to work. (A standard Linux “agetty” process is used to implement serial control internally.) See the “Programming Manual for -B Instruments” for more details on RS-232 control.
8.  DC IN (+) Connector. This power input connector must be connected to the positive (+) output of the user-supplied external DC power supply. This connector will accept 6 mm safety sockets, or 4 mm "banana" plugs. (6 mm safety sockets will have considerably higher current capability). Beware that the 6 mm cables "lock" into the mating adapters. **To release the lock, push the cable inwards FIRST, and THEN pull it out of the adapter.** The cable will not be released if you simply pull on it.
9.  GND (-) Connector. This power input connector must be connected to the negative (-) output of the user-supplied external DC power supply. This connector will accept 6 mm safety sockets, or 4 mm "banana" plugs. (6 mm safety sockets will have considerably higher current capability). Beware that the 6 mm cables "lock" into the mating adapters. **To release the lock, push the cable inwards FIRST, and THEN pull it out of the adapter.** The cable will not be released if you simply pull on it.
10.  OUT/GND Connector. This is the main output connector (Positronic part number GG8888F1, with four GGFIT00MS/AA high-current contacts). The inner two contacts carry the signal, and the outer two carry the ground lines. The optional AV-HLZ1-100 cable or the AV-HLZAX test load may be plugged into this connector (these items are supplied with the -AK9 accessory kit option). Alternatively, the user may construct their own mating connector, by ordering Positronic ([www.positronic.com](http://www.positronic.com)) part number GG8888M1, with four GGMIT00MS/AA high-current contacts.
11.  AMP Connector. This is a current monitor output. This output provides a voltage waveform that is proportional to the current waveform on the output. The monitor relationship is:  $V_{MON} = I_{OUT} \times 2.5V / 50A$ , for a load of  $> 1 k\Omega$ . (The monitor output can also drive a  $50\Omega$  load, but the output voltage will be reduced by a factor of 2.

This output is short-circuit protected.)

12. Network Connector. (Optional feature. Present on -VXI units only.) This Ethernet connector allows the instrument to be remotely controlled using the VXI-11.3, ssh (secure shell), telnet, and http (web) protocols. See the “Programming Manual for -B Instruments” for more details.

## PULSE GENERATOR TIMING

### BASIC PULSE CONTROL

This instrument can be triggered by its own internal clock or by an external TTL trigger signal. In either case, two output channels respond to the trigger: OUT and SYNC. The OUT channel is the signal that is applied to the load. Its amplitude and pulse width are variable. The SYNC pulse is a fixed-width TTL-level reference pulse used to trigger oscilloscopes or other measurement systems. When the delay is set to a positive value the SYNC pulse precedes the OUT pulse. When the delay is set to a negative value the SYNC pulse follows the OUT pulse.

These pulses are illustrated below, assuming internal triggering and positive delay:

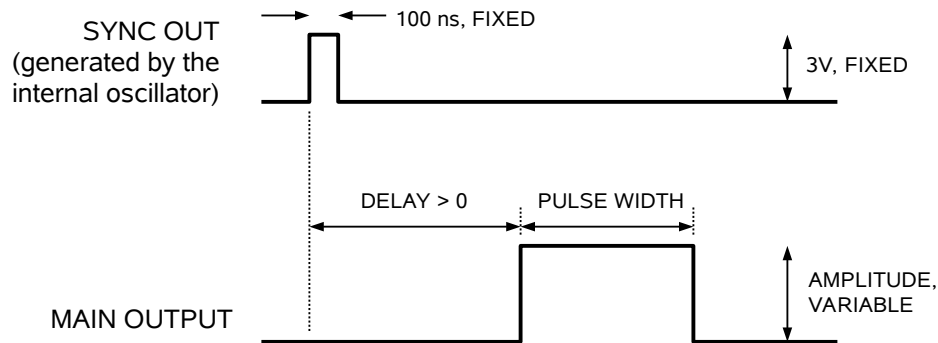

If the delay is negative, the order of the SYNC and OUT pulses is reversed:

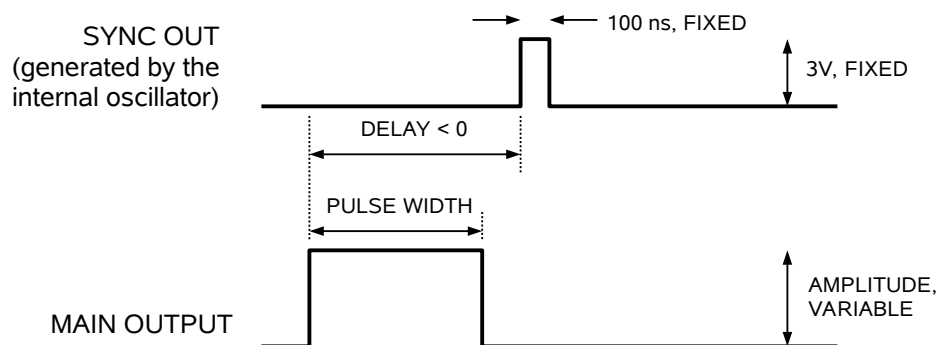

The next figure illustrates the relationship between the signals when an external TTL-level trigger is used:

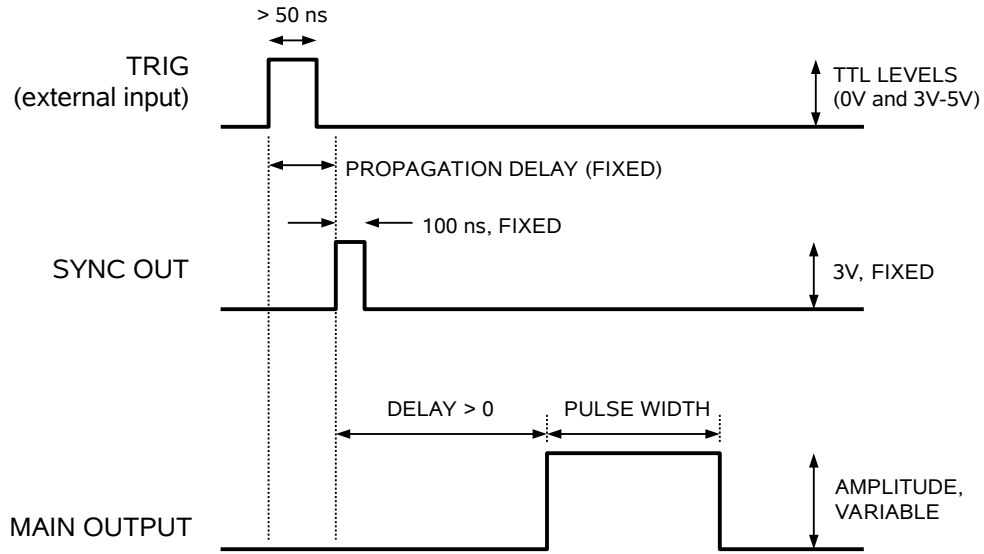

As before, if the delay is negative, the order of the SYNC and OUT pulses is reversed.

The last figure illustrates the relationship between the signal when an external TTL-level trigger is used in the  $PW_{IN}=PW_{OUT}$  mode. In this case, the output pulse width equals the external trigger's pulse width (approximately), and the delay circuit is bypassed:

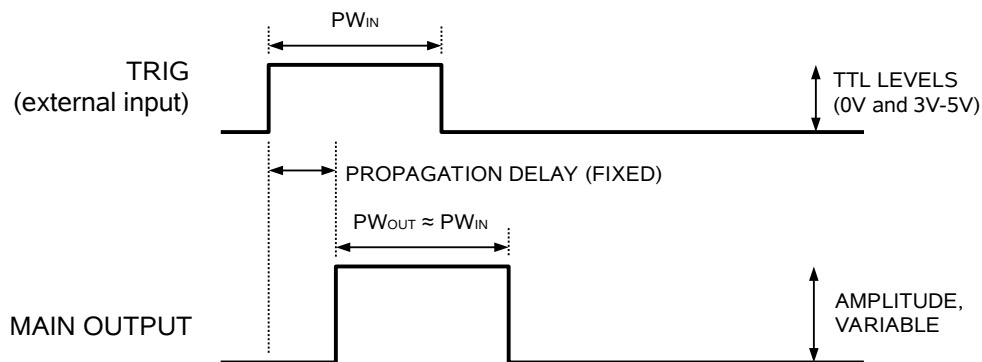

The delay, pulse width, and frequency (when in the internal mode), of the main output pulse can be varied with front panel controls or via the GPIB or RS-232 computer interfaces.

⚠ Do not exceed a repetition rate of 1 kHz when triggering externally. Excessive repetition rates may cause over-heating internally, and possible damage the instrument.



## TRIGGER MODES

This instrument has four trigger modes:

- Internal Trigger: the instrument controls the trigger frequency, and generates the clock internally.
- External Trigger: the instrument is triggered by an external TTL-level clock on the back-panel TRIG connector.
- Manual Trigger: the instrument is triggered by the front-panel “SINGLE PULSE” pushbutton.
- Hold Trigger: the instrument is set to not trigger at all.

These modes can be selected using the front panel trigger menu, or by using the appropriate programming commands. (See the “Programming Manual for -B Instruments” for more details.)

## PULSE WIDTH MODES

This instrument has two pulse width modes:

- Normal: the instrument controls the output pulse width.
- $PW_{IN}=PW_{OUT}$ : the output pulse width equals the pulse width of the trigger signal on the “TRIG” connector. The instrument must be in the external trigger mode.

These modes can be selected using the front panel pulse width menu, or by using the appropriate programming commands. (See the “Programming Manual for -B Instruments” for more details.)

## GATING MODES

Triggering can be suppressed by a TTL-level signal on the rear-panel GATE connector. The instrument can be set to stop triggering when this input high or low, using the front-panel gate menu or the appropriate programming commands. This input can also be set to act synchronously or asynchronously. When set to asynchronous mode, the GATE will disable the output immediately. Output pulses may be truncated. When set to synchronous mode, the output will complete the full pulse width if the output is high, and then stop triggering. No pulses are truncated in this mode.

## CONNECTING TO A POWER SUPPLY

The basic connection arrangement for the AV-109F-3-B-P is shown below. The AV-109F-3-B-P must be connected to a user-supplied external DC power supply. Specifically, the "DC IN (+)" rear-panel connector (which is identified with a red ring) should be connected to the positive output of the power supply, and the "GND (-)" rear-panel connector (which is identified with a black ring) should be connected to the negative output of the power supply. If the AV-109F-3-B-P has been ordered with the - AK3 accessory kit, the included red and black cables are suggested for this purpose.

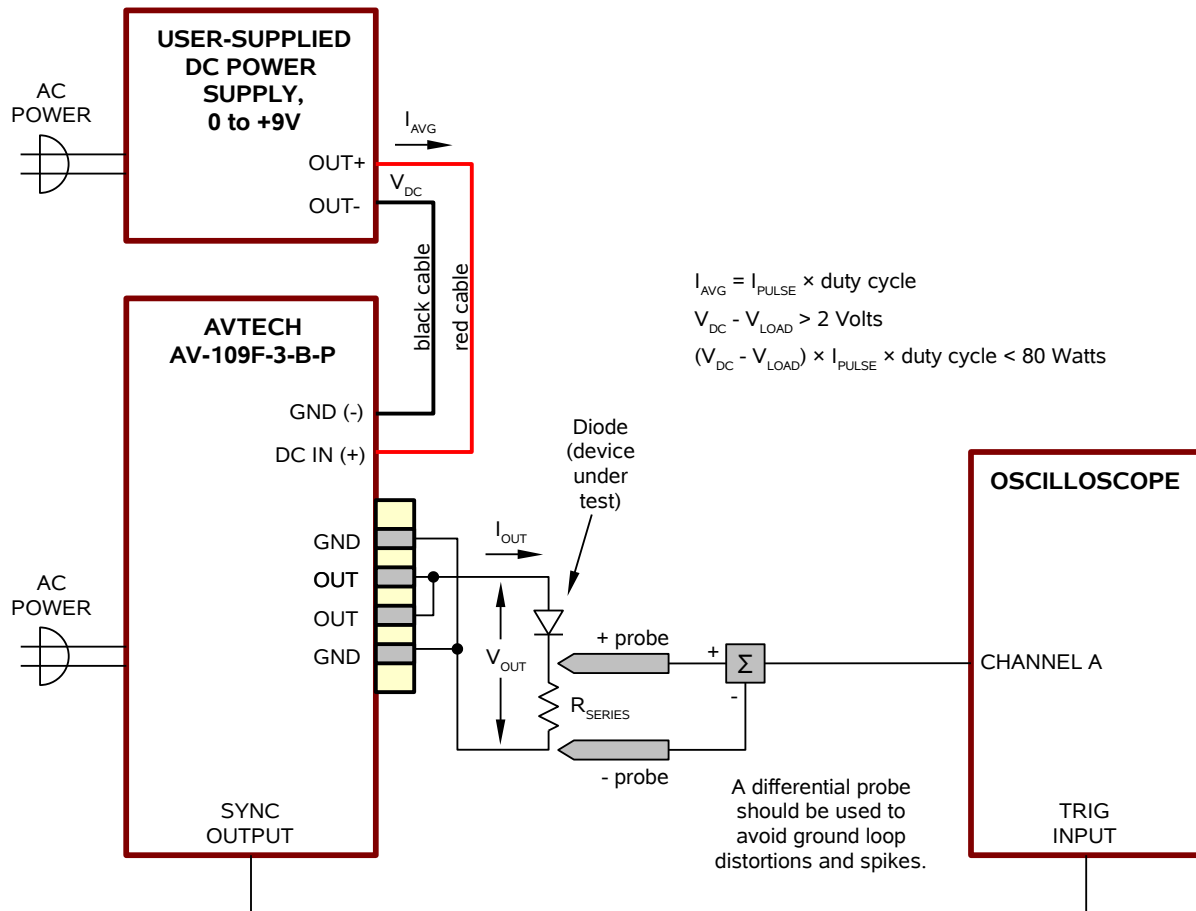

Possible DC power supplies for use with the AV-109F-3-B-P are listed in the Specifications section (page 8).

## GROUNDING ISSUES

To avoid ground loops that might distort measurements, a differential oscilloscope probe should be used to view the output waveform (i.e., a probe where neither of the

two clips is shorted to ground). Some factory tests are conducted using a Tektronix P5205 differential probe.

A standard non-differential probe can be used, but “spikes” may appear on the rising and falling edges, or the pulse top may show “rounding”, due to ground potential differences between the locations of the load, the pulse generator, and the oscilloscope.

The parasitic inductance present in the load, the wiring, and the measurement circuitry may introduce negative voltage “spikes” on the falling edge of the waveform. In general, they do not correspond to negative current spikes – they are measurement artifacts. They can often be reduced by installing a reverse-oriented “clipping” diode in parallel with the load.

### USING THE 6 mm CONNECTORS

The four 6 mm connectors on the rear panel are designed to accept cables terminated with 6 mm sockets or 4 mm "banana" plugs.

4 mm "banana" plug cables are quite common, and are used with many lower-current DC power supplies. However, if you intend to operate at high average currents ( $I_{AVG} > 15$  Amps) then they are probably unsuitable, and 6 mm socket cables should be used instead.

The higher-current 6 mm socket cables are less common. See the "AK4 Accessory Kit Section" for details about suitable cables and adapters.

Beware that the 6 mm cables "lock" into the mating adapters. ***To release the lock, push the cable inwards FIRST, and THEN pull it out of the adapter.*** The cable will not be released if you simply pull on it.

A typical power supply to pulser connection is shown below.

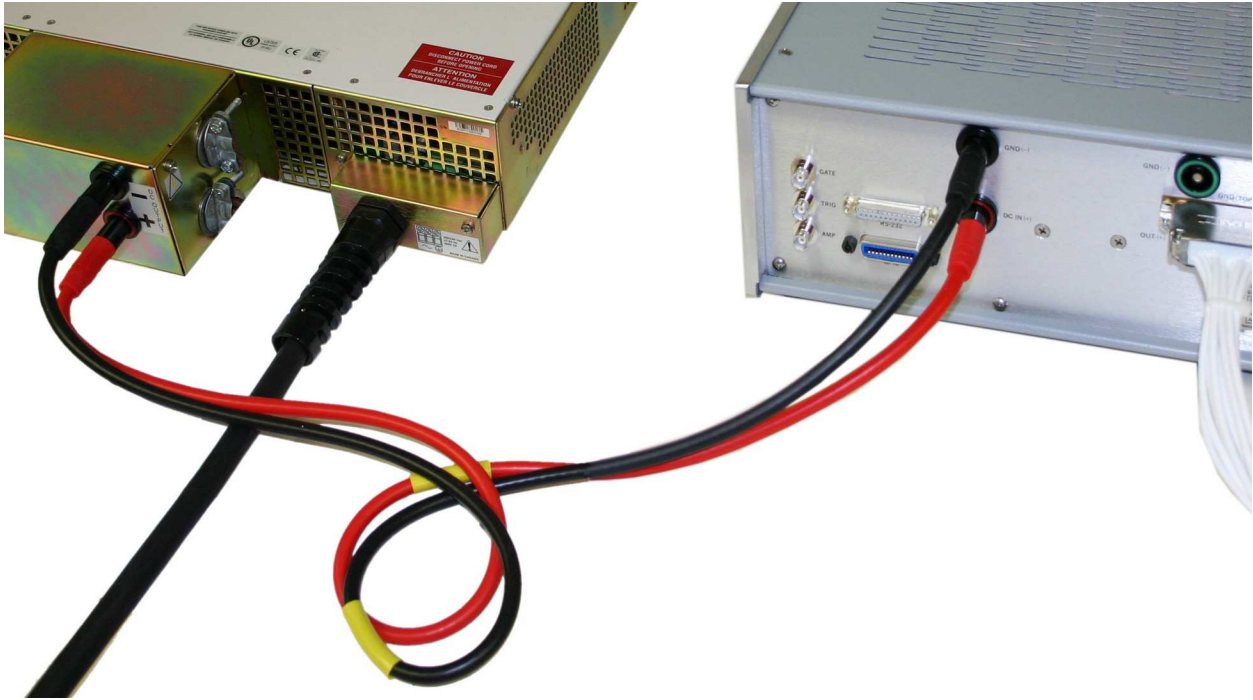

The next photo shows how 4 mm "banana" cables will also mate to the DC power input connectors:

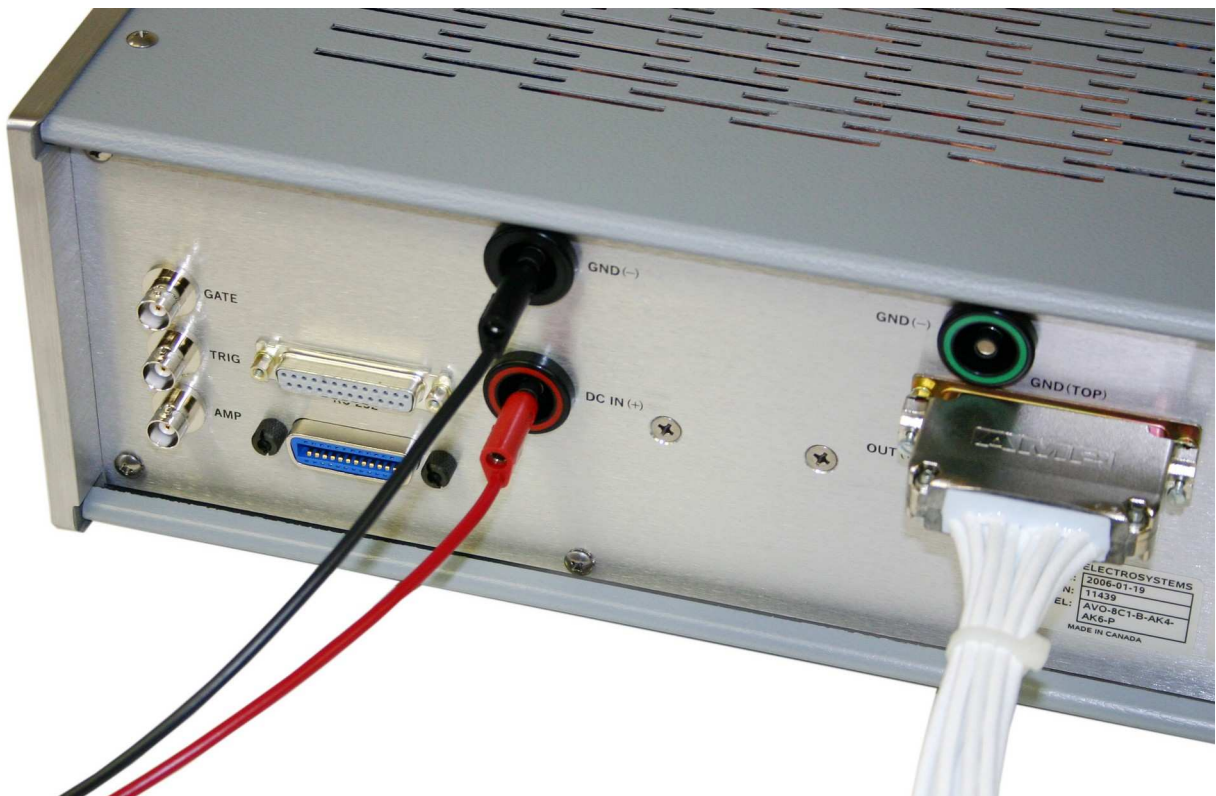

## SETTING THE DC POWER SUPPLY VOLTAGE LEVEL

The AV-109F-3-B-P requires a user-supplied external DC power supply, capable of supplying the necessary average current to the instrument ( $I_{AVG}$ ). The peak current is supplied by a large capacitor bank inside the pulser. The voltage from the external power supply ( $V_{DC}$ ) must be at least 2 Volts greater than the maximum expected load voltage ( $V_{LOAD}$ ). The maximum difference between  $V_{DC}$  and the maximum  $V_{LOAD}$  must also be controlled to limit the power dissipation in the instrument to 80 Watts:

$$\begin{aligned} V_{DC} - V_{LOAD} &> 2 \text{ Volts} \\ (V_{DC} - V_{LOAD}) \times I_{AVG} &< 80 \text{ Watts} \end{aligned}$$

For example, if the AV-109F-3-B-P is operating at 50% duty cycle and 50 Amps, for an average current of 20A, then  $V_{DC}$  should be between 2 and 4 Volts ( $80W / 20A = 4V$ ) higher than  $V_{LOAD}$ . If  $V_{DC}$  is too high, the output circuits will overheat and protective sensors will disable the output. The maximum permitted value of  $V_{DC}$  is 9V.

## INSTRUMENT AND LOAD PROTECTION

### LENZ'S LAW AND INDUCTIVE VOLTAGE SPIKES

This instrument is designed to pulse resistive and diode loads and will exhibit a large output spike when used to drive a load with significant inductance (as predicted by LENZ'S LAW). For this reason the load should be connected to the output using low inductance leads (as short as possible and as heavy a gauge as possible).

Wirewound resistors are not acceptable resistive loads, unless many are connected together in parallel.

The voltage developed across an inductance  $L$  (in Henries), when the current is changing at a rate given by  $di_{LOAD}/dt$  (in Amps/sec), is:  $V_{SPIKE} = L \times di_{LOAD}/dt$ .

Some load inductance is unavoidable. As a result, the output voltage waveform (measured across a resistance) will have some distortion on the leading edge, as shown:

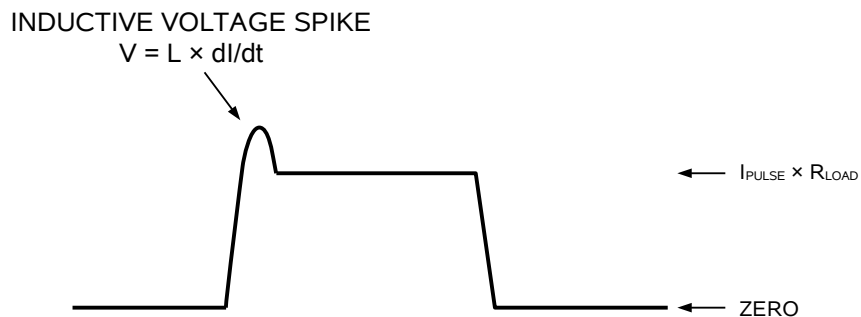

If the voltage spike rises to a voltage near the DC voltage of the attached DC power supply, the output circuitry may lose control of the output current waveform, resulting in the output current waveform.

### ATTACHING AND DETACHING LOADS

To avoid damaging the loads connected to main outputs, the loads should only be connected to or removed from the instrument when the instrument is off. Do not connect loads when the instrument is on. This can cause sparking.

### ATTACHING AND DETACHING THE POWER SUPPLY

The DC power supply should always be connected to the mainframe **BEFORE power is applied** to either item.

### CHANGING PARAMETERS WHEN A LOAD IS ATTACHED

If your load is easily damaged, the amplitude should be reduced to zero before changing the trigger source, frequency, pulse width, or other pulse parameters. This protects the loads from possible short transient effects.

### QUIESCENT CURRENT

The AV-109F-3-B-P output circuit has special circuitry to ensure that the output current between pulses is very close to zero.

The pulse generation circuitry is connected to the output connectors through a Schottky diode. During pulse generation, this diode is forward biased. Between pulses, this diode is reversed biased by a -1V DC level inside the instrument, ensuring that no positive current will develop on the load. A small negative leakage current (between 10  $\mu$ A and 1 mA) may develop in the output diodes, depending on the attached load, which will tend to reverse bias any attached diode load. However, this reverse bias will never be greater than -1V.

## AK3, AK4, AK5 ACCESSORY KITS

### KIT CONTENTS

The AK3, AK4, and AK5 accessory kits contain cables terminated with 6 mm safety sockets, and matching 6 mm safety plug to M4 stud adapters.

The AK3 kit contains two cables (one red, one black) and two adapters (one red, one black).

The AK5 kit contains two cables (one yellow, one green) and two adapters (one yellow, one green).

The AK4 kit contains four cables (one each of red, black, yellow, and green) and four adapters (one each of red, black, yellow, and green). The AK4 kit is shown below:



The cable colors (red, black, yellow, or green) refer to the identifying bands on the end of the cables. The bulk of the cable is red for the “red” cable, black for the “green” and “black” cables. The bulk of the “yellow” cable shown above is black, but it may be green/yellow stripe combination instead, due to the manufacturer’s (Multi-Contact) variations.



## SPECIFICATIONS

Type	Series	Color	Multi-Contact Part Number	Rated Current (DC)	Rated Current (1 sec pulse)
1 meter Cable with 6 mm safety sockets	Multi-Contact SLK616-AR/BGG	Red	15.2502-100-22	100 A	1200 A
		Black	15.2502-100-21		
		Yellow	15.2502-100-24*		
		Green	15.2502-100-25*		
6 mm safety plug to M4 stud adapter	Multi-Contact ID/S6AR-N-B4S	Red	14.0034-22	100 A	1200 A
		Black	14.0034-21		
		Yellow	14.0034-24		
		Green	14.0034-25		

\* May be a "special order" part for Multi-Contact.

## GENERAL INFORMATION

The red and black cables are typically used to connect an Avtech pulse generator to a DC power supply (red = +, black = -). If your DC power supply does not provide its outputs on 6 mm safety plugs, then it may be necessary to use the red and black 6 mm safety plug to M4 stud adapters to build an appropriate connection to your power supply.

The yellow and green cables are typically plugged directly into the matching 6 mm plug connectors on the rear panel of an Avtech high-current pulse generator. The yellow and green 6 mm safety plug to M4 stud adapters are provided so that an appropriate connection may be made to your load.

Beware that these 1 meter cables have an inductance of approximately 0.6  $\mu$ H, and they may not be appropriate for high-speed use. The inductance will introduce an inductive time constant of  $\tau = L / R$ , where  $L = 0.6 \mu\text{H}$ , and  $R =$  your load resistance. It may be necessary to trim the cables for faster speeds.

The cables "lock" into the mating adapters. **To release the lock, push the cable inwards FIRST, and THEN pull it out of the adapter.** The cable will not be released if you simply pull on it.

## REPLACEMENT PARTS AND OTHER ACCESSORIES

The parts in this accessory kit, and other mating accessories, are available individually from the manufacturer, Multi-Contact (see <http://www.multi-contact-usa.com> or <http://www.multi-contact.com>).

## CONNECTING TO THE LOAD

The main output connector is a Positronic part number GG8888F1, with four GGFIT00MS/AA high-current contacts.

The inner two contacts carry the signal, and the outer two carry the ground lines.

The optional AV-HLZ1-100 cable or the AV-HLZAX test load may be plugged into this connector (these items are supplied with the -AK9 accessory kit option). Alternatively, the user may construct their own mating connector, by ordering Positronic ([www.positronic.com](http://www.positronic.com)) part number GG8888M1, with four GGFIT00MS/AA high-current contacts.

Note the alignment grooves. Mating connectors must be positioned appropriately.

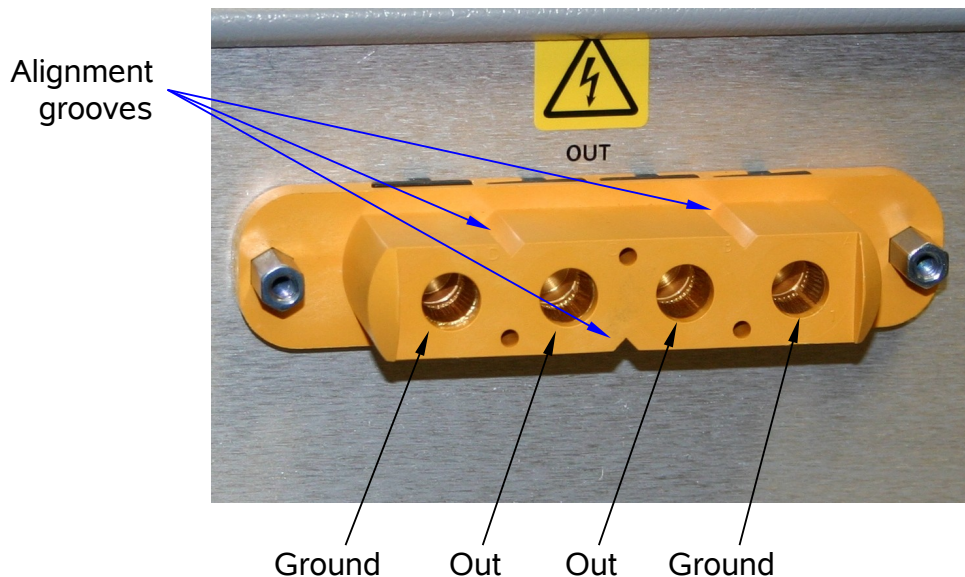

### AV-HLZ1-100 CABLE

One AV-HLZ1-100 cable is provided with the optional -AK9 accessory kit. One end of the cable mates to the rear-panel OUT connector.

The cable is specially designed to have a transmission line characteristic impedance ( $Z_0$ ) of approximately 1 Ohm, to minimize distortions and reflections.

The cable may be attached to the OUT connector simply by inserting the male end of the cable into the OUT connector, taking care to align the alignment grooves. The jack screws may be used to secure the cable to the connector.

An attached cable is shown below:



### AV-HLZAX ADAPTER

An AV-HLZAX adapter is provided with the optional -AK9 accessory kit.

The AV-HLZAX adapter may be plugged directly into the rear-panel OUT connector, or it may be plugged into the end of the AV-HLZ1-100 cable. Both configurations are shown below (the green resistors shown in the photos are not included):





In both cases, the OUTPUT signal is provided on the NARROW copper strip, and the GROUND is provided on the WIDE copper strip. This is shown schematically below:

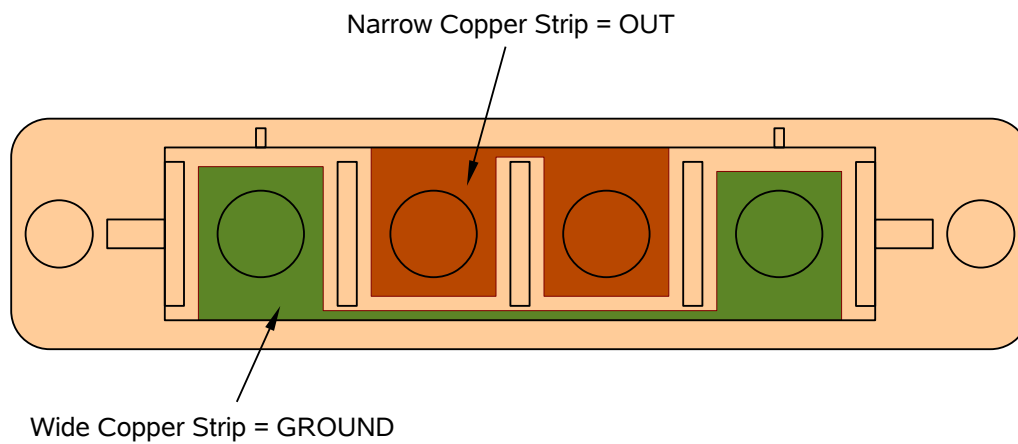

*End View of AV-HLZA*

The load may be installed between these two strips, as shown in a side view:

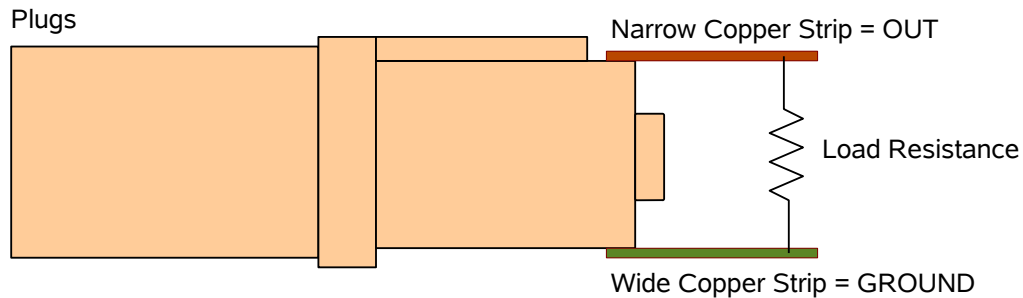

*Side View of AV-HLZA*

The copper strips may be removed entirely, if the user wishes to construct their own load attachment arrangement. If the copper strips are removed, the OUT and GROUND signals may be accessed using the four high-current posts, which are terminated with M6-1.0 internal threads. An M6-1.0x12 screw should be used to attach cabling to each of the four posts. The inner two posts carry the OUT signal, and the outer two posts carry the ground:

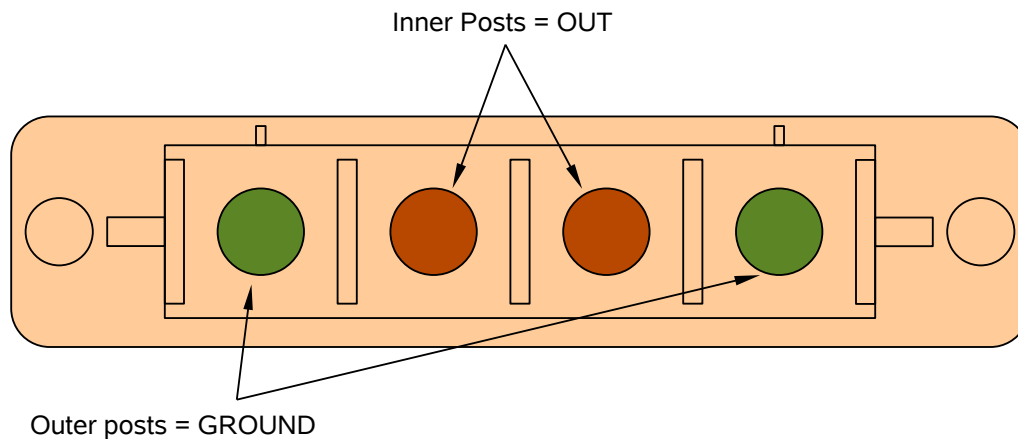

*End View of AV-HLZA,  
With Copper Strips Removed*

For maximum current carrying capability (i.e., least resistance), all four posts should be used.

### THERMAL NOTES

⚠ Due to the very high average and peak currents that can be produced by the AV-109F-3-B-P, the output cables and connectors may become warm to the touch. However, they should NOT become uncomfortable to the touch ( $> 50^{\circ}\text{C}$ ). If they do,

turn off the instrument and re-consider your cabling scheme or reduce the output duty cycle.

## CURRENT MONITOR

A current monitor output is provided on the rear panel of the instrument. The voltage waveform of the monitor output is proportional to the current waveform on the main output:

$$V_{\text{MON}} \approx I_{\text{OUT}} \times 2.5\text{V} / 50\text{A}$$

for a load of  $> 1 \text{ k}\Omega$ . (The monitor output can also drive a  $50\Omega$  load, but the output voltage will be reduced by a factor of 2. This output is short-circuit protected.)

The current monitor circuit also measures the amplitude of the most recent pulse, in amperes, and displays it on the front panel LCD. The value can also be read via the computer interface.

## ALARMS

The AV-109F-3-B-P has several protective circuits. An alarm circuit, with an audible buzzer, will sound and disable the output if:

- 1) The DC power supply voltage exceeds 10V.
- 2) The DC power supply voltage is the wrong polarity.
- 3) The output circuitry overheats.

The buzzer may sound briefly when the power is first switched on. This is normal, and not a cause for concern.

If the alarm sounds, turn off the instrument and determine what has caused the alarm. Do not proceed until you have determined this.

## OPERATIONAL CHECK

This section describes a sequence to confirm the basic operation of the instrument. It should be performed after receiving the instrument. It is a useful learning exercise as well.

Before proceeding with this procedure, finish reading this instruction manual thoroughly. Then read the “Local Control” section of the “Programming Manual for -B Instruments” thoroughly. The “Local Control” section describes the front panel controls used in this operational check - in particular, the MOVE, CHANGE, and ADJUST controls.

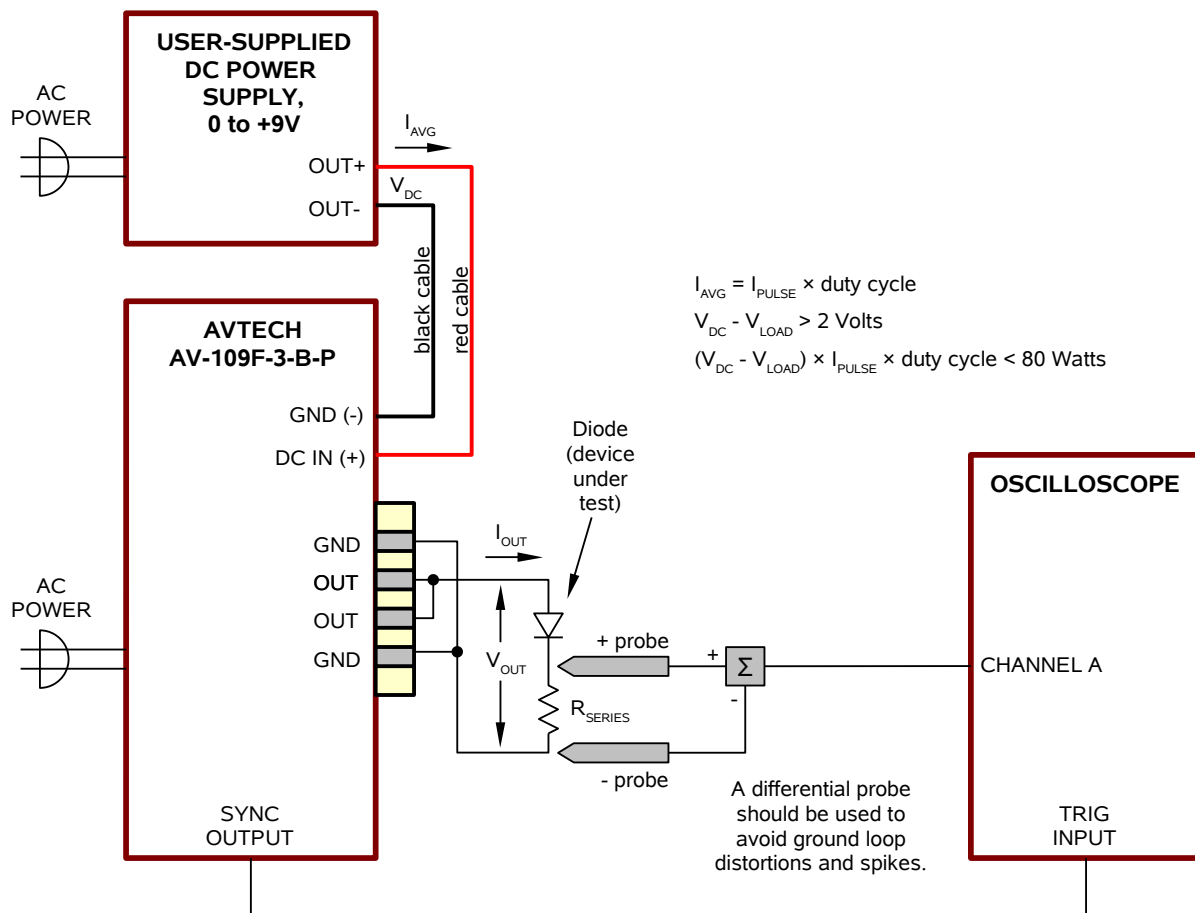

*Basic Test Arrangement*

1. With the instruments turned off, connect a DC power supply to the AV-109F-3-B-P, as shown above.
2. Connect a high-power 0.1 Ohm test load between the two OUT posts of the rear-panel output connector and the two GND posts of the connector. Factory tests are performed with the Avtech AV-HTL-0R1-HLZ test load (see



<http://www.avtechpulse.com/accessories/av-htl-0r1> for details.)

3. Connect a cable from the SYNC OUT connector to the TRIG input of an oscilloscope. Set the oscilloscope to trigger externally.
4. Connect a differential probe across the load. On the oscilloscope, set the vertical scale to 2 V/div, and the horizontal scale to 50 us/div.
5. Turn on the AV-109F-3-B-P and the DC power supply. Set the DC power supply voltage to +7.5V.
6. To set the AV-109F-3-B-P to trigger from the internal clock at a PRF of 10 Hz:
  - a) The arrow pointer should be pointing at the frequency menu item. If it is not, press the MOVE button until it is.
  - b) Press the CHANGE button. The frequency submenu will appear. Rotate the ADJUST knob until the frequency is set at 10 Hz.
  - c) The arrow pointer should be pointing at the “Internal” choice. If it is not, press MOVE until it is.
  - d) Press CHANGE to return to the main menu.
7. To set the delay to 50 us:
  - a) Press the MOVE button until the arrow pointer is pointing at the delay menu item.
  - b) Press the CHANGE button. The delay submenu will appear. Rotate the ADJUST knob until the delay is set at 50 us.
  - c) Press CHANGE to return to the main menu.
8. To set the OUT pulse width to 200 us:
  - a) Press the MOVE button until the arrow pointer is pointing at the “PW” menu item.
  - b) Press the CHANGE button. The pulse width submenu will appear. Rotate the ADJUST knob until the pulse width is set at 200 us.
  - c) The arrow pointer should be pointing at the “Normal” choice. If it is not, press MOVE until it is.
  - d) Press CHANGE to return to the main menu.
9. At this point, nothing should appear on the oscilloscope.

10. To enable the output:

- a) Press the MOVE button until the arrow pointer is pointing at the output menu item.
- b) Press the CHANGE button. The output submenu will appear.
- c) Press MOVE until the arrow pointer is pointing at the "ON" choice.
- d) Press CHANGE to return to the main menu.

11. To change the OUT output amplitude:

- a) Press the MOVE button until the arrow pointer is pointing at the AMP menu item.
- b) Press the CHANGE button. The amplitude submenu will appear. Rotate the ADJUST knob until the amplitude is set at 50A.
- c) Observe the oscilloscope. You should see 200 us wide, 5V pulses (i.e.,  $50A \times 0.1\Omega = 5V$ ).
- d) Press CHANGE to return to the main menu.

12. Try reducing the pulse width, by repeating step (7). As you rotate the ADJUST knob, the pulse width on the oscilloscope will change. It should agree with the displayed value.

13. This completes the operational check.

## PROGRAMMING YOUR PULSE GENERATOR

### KEY PROGRAMMING COMMANDS

The “Programming Manual for -B Instruments” describes in detail how to connect the pulse generator to your computer, and the programming commands themselves. A large number of commands are available; however, normally you will only need a few of these. Here is a basic sample sequence of commands that might be sent to the instrument after power-up, using the internal trigger source:

*rst	(resets the instrument)
trigger:source internal	(selects internal triggering)
frequency 1 Hz	(sets the frequency to 1 Hz)
pulse:width 200 us	(sets the pulse width to 200 us)
pulse:delay 100 us	(sets the delay to 100 us)
output on	(turns on the output)
source:current 10A	(sets the current amplitude to 10 Amperes)
measure:amplitude?	(this returns the peak current, in amperes, as measured by the monitor circuit)

For triggering a single event, this sequence would be more appropriate:

*rst	(resets the instrument)
trigger:source hold	(turns off all triggering)
pulse:width 200 us	(sets the pulse width to 200 us)
pulse:delay 100 us	(sets the delay to 100 us)
output on	(turns on the output)
source:current 10A	(sets the current amplitude to 10 Amperes)
trigger:source immediate	(generates a single non-repetitive trigger event)
trigger:source hold	(turns off all triggering)
output off	(turns off both outputs)

These commands will satisfy 90% of your programming needs.

### ALL PROGRAMMING COMMANDS

For more advanced programmers, a complete list of the available commands is given below. These commands are described in detail in the “Programming Manual for -B Instruments”. (Note: this manual also includes some commands that are not implemented in this instrument. They can be ignored.)

<u>Keyword</u>	<u>Parameter</u>	<u>Notes</u>
DIAGnostic:		
:AMPLitude		
:CALibration		

:POINT	<numeric value> <numeric value>	
:MONitor		
:CALibration	<numeric value>	[no query form]
:STEP	<numeric value>	
MEASure:		
:AMPLitude?		[query only]
OUTPut:		
:[STATe]	<boolean value>	
:PROTection		
:TRIPped?		[query only]
[SOURce]:		
:FREQuency		
[:CW   FIXed]	<numeric value>	
[SOURce]:		
:CURRent		
[:LEVe]		
[:IMMediate]		
[:AMPLitude]	<numeric value>	
:PROTection		
:TRIPped?		[query only]
[SOURce]:		
:PULSe		
:PERiod	<numeric value>	
:WIDTh	<numeric value>	
:DCYCLe	<numeric value>	
:HOLD	WIDTh   DCYCLe	
:DELay	<numeric value>	
:GATE		
:LEVe	High   Low	
:TYPE	ASYNc   SYNc	
STATUS:		
:OPERation		
:[EVENT]?		[query only, always returns "0"]
:CONDition?		[query only, always returns "0"]
:ENABle	<numeric value>	[implemented but not useful]
:QUEStionable		
:[EVENT]?		[query only, always returns "0"]
:CONDition?		[query only, always returns "0"]
:ENABle	<numeric value>	[implemented but not useful]
SYSTEM:		
:COMMunicate		
:GPIB		
:ADDReSS	<numeric value>	
:SERial		
:CONTRol		
:RTS	ON   IBFull   RFR	
:[RECeive]		
:BAUD	1200   2400   4800   9600   19200   38400   57600   115200	
:ERRor		
:[NEXT]?		[query only]
:COUNT?		[query only]
:VERSion?		[query only]
TRIGger:		
:SOURce	INTernal   EXTernal   MANual   HOLD   IMMEDIATE	
*CLS		[no query form]
*ESE	<numeric value>	
*ESR?		[query only]
*IDN?		[query only]

*OPC		
*SAV	0   1   2   3	[no query form]
*RCL	0   1   2   3	[no query form]
*RST		[no query form]
*SRE	<numeric value>	
*STB?		[query only]
*TST?		[query only]
*WAI		[no query form]

## MECHANICAL INFORMATION

### TOP COVER REMOVAL

If necessary, the interior of the instrument may be accessed by removing the four Phillips screws on the top panel. With the four screws removed, the top cover may be slid back (and off).

 Always disconnect the power cord and allow the instrument to sit unpowered for 10 minutes before opening the instrument. This will allow any internal stored charge to discharge.

There are no user-adjustable internal circuits. For repairs other than fuse replacement, please contact Avtech (info@avtechpulse.com) to arrange for the instrument to be returned to the factory for repair. Service is to be performed solely by qualified service personnel.

 Caution: High voltages are present inside the instrument during normal operation. Do not operate the instrument with the cover removed.

### RACK MOUNTING

A rack mounting kit is available. The -R6 rack mount kit may be installed after first removing the one Phillips screw on the side panel adjacent to the front handle.

### ELECTROMAGNETIC INTERFERENCE

To prevent electromagnetic interference with other equipment, all used outputs should be connected to shielded loads using shielded coaxial cables. Unused outputs should be terminated with shielded coaxial terminators or with shielded coaxial dust caps, to prevent unintentional electromagnetic radiation. All cords and cables should be less than 3m in length.

## MAINTENANCE

### REGULAR MAINTENANCE

This instrument does not require any regular maintenance.

On occasion, one or more of the four rear-panel fuses may require replacement. All fuses can be accessed from the rear panel. See the “FUSES” section for details.

### CLEANING

If desired, the interior of the instrument may be cleaned using compressed air to dislodge any accumulated dust. (See the “TOP COVER REMOVAL” section for instructions on accessing the interior.) No other cleaning is recommended.

# WIRING DIAGRAMS

## WIRING OF AC POWER

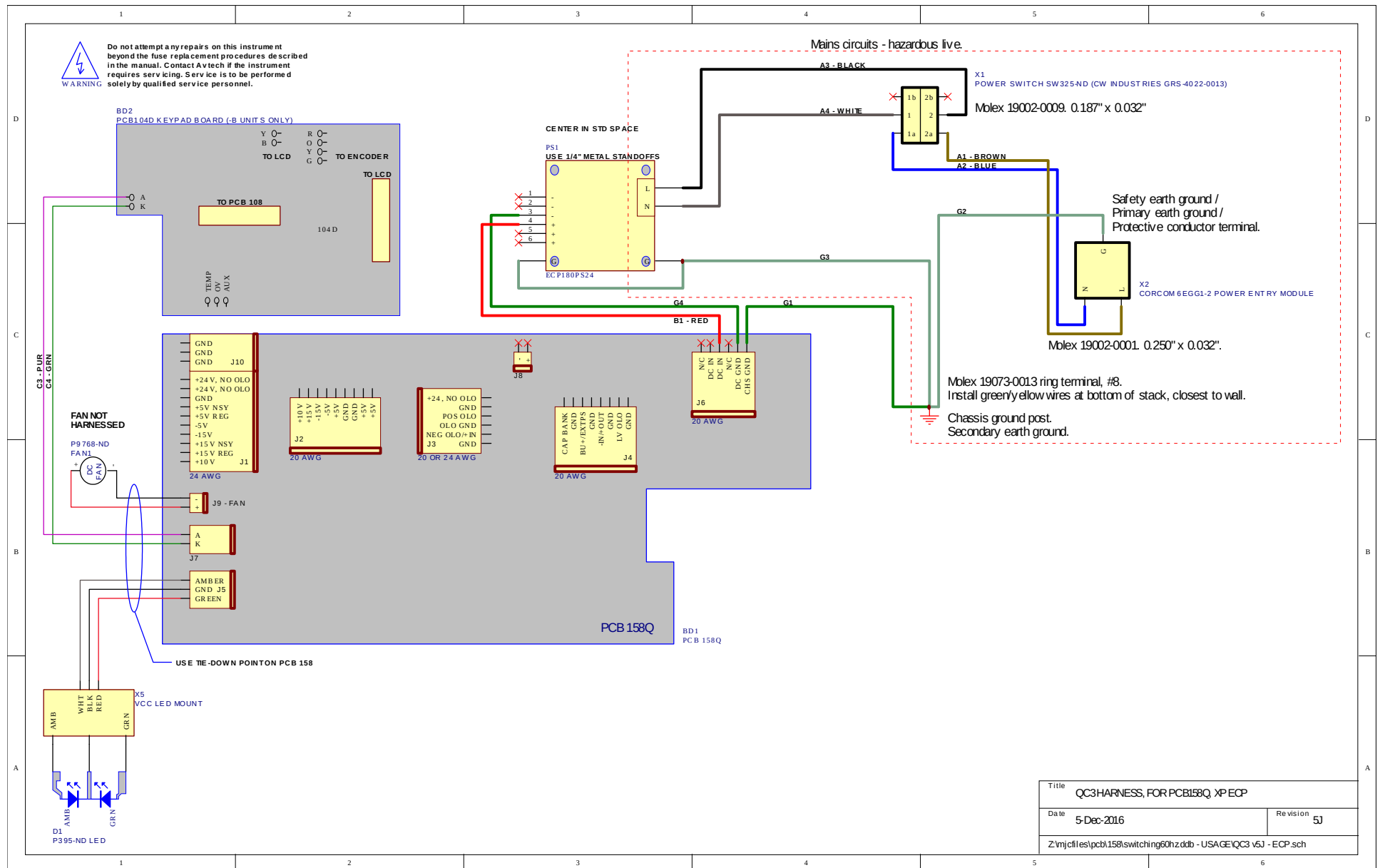

Title		QC3 HARNESS, FOR PCB158Q, XP ECP	
Date	5-Dec-2016	Revision	5J
Z:\njcf\es\pcb158\switching60hzddb - USAGE\QC3 v5J - ECP.sch			



# PCB 158Q - LOW VOLTAGE POWER SUPPLY, 1/3

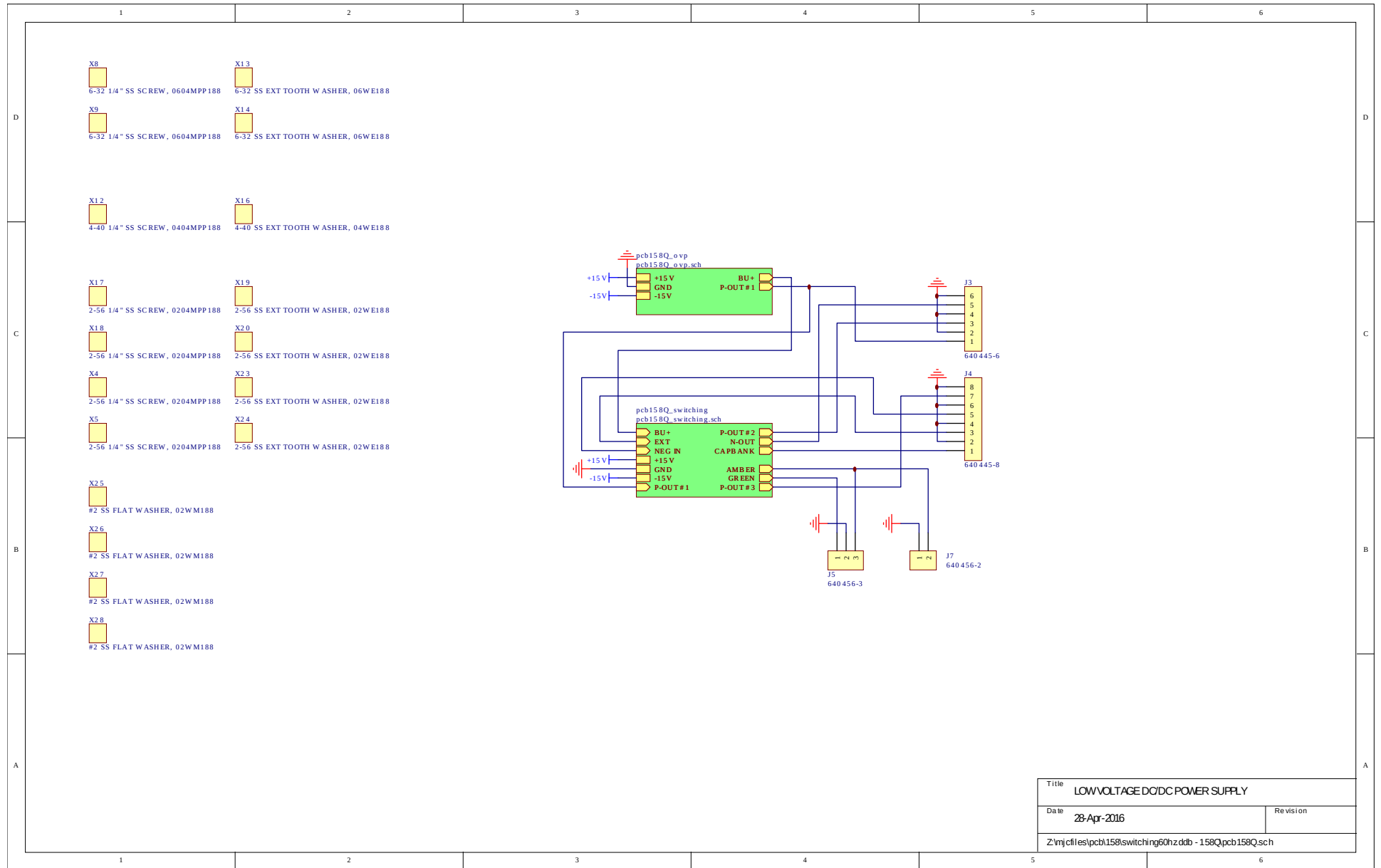

Title		LOW VOLTAGE DC/DC POWER SUPPLY
Date	28-Apr-2016	Revision
Z:\njcf\es\pcb158\switching60hzddb - 158Q.pcb158Q.sch		

# PCB 158Q - LOW VOLTAGE POWER SUPPLY, 2/3

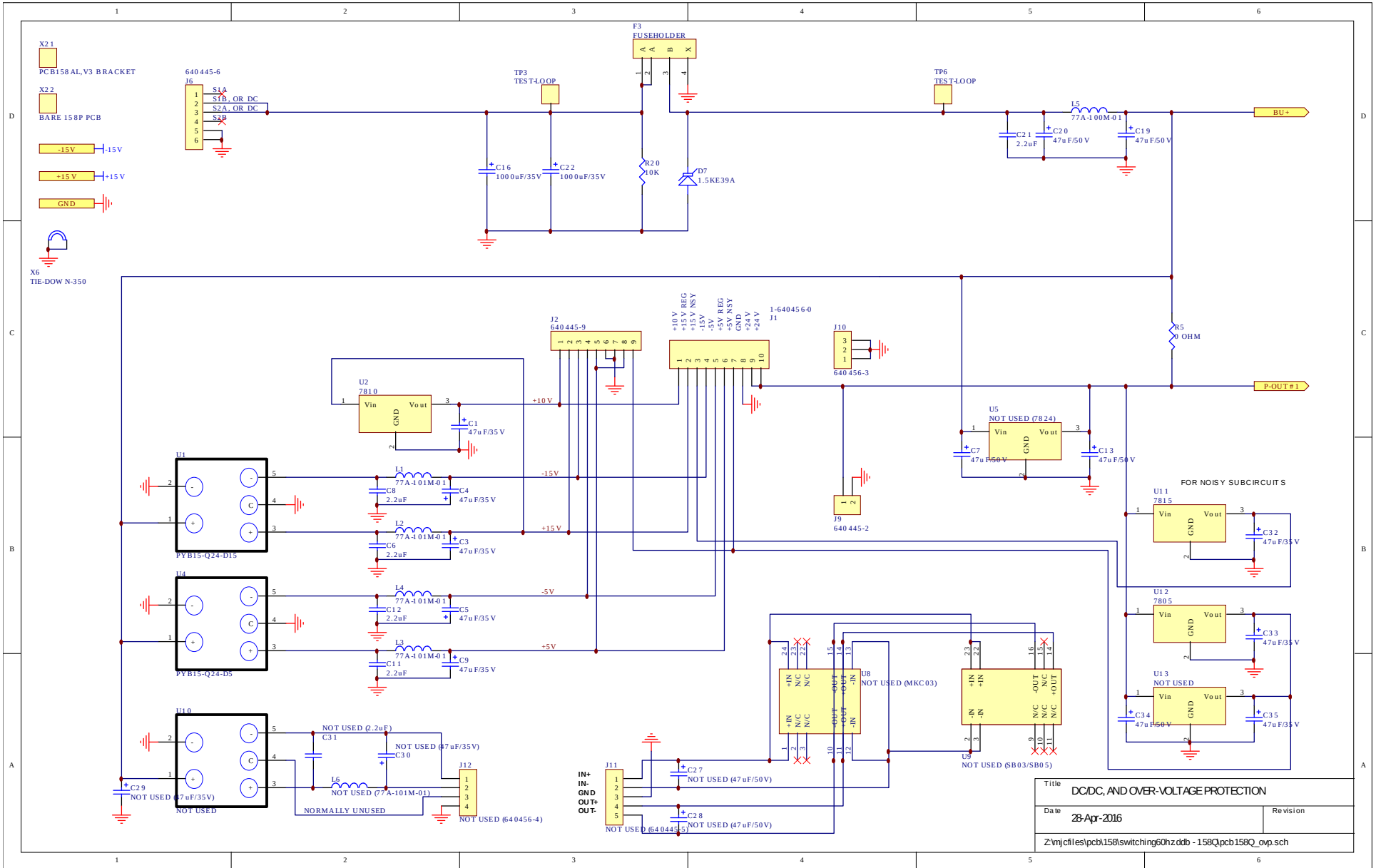

# PCB 158Q - LOW VOLTAGE POWER SUPPLY, 3/3

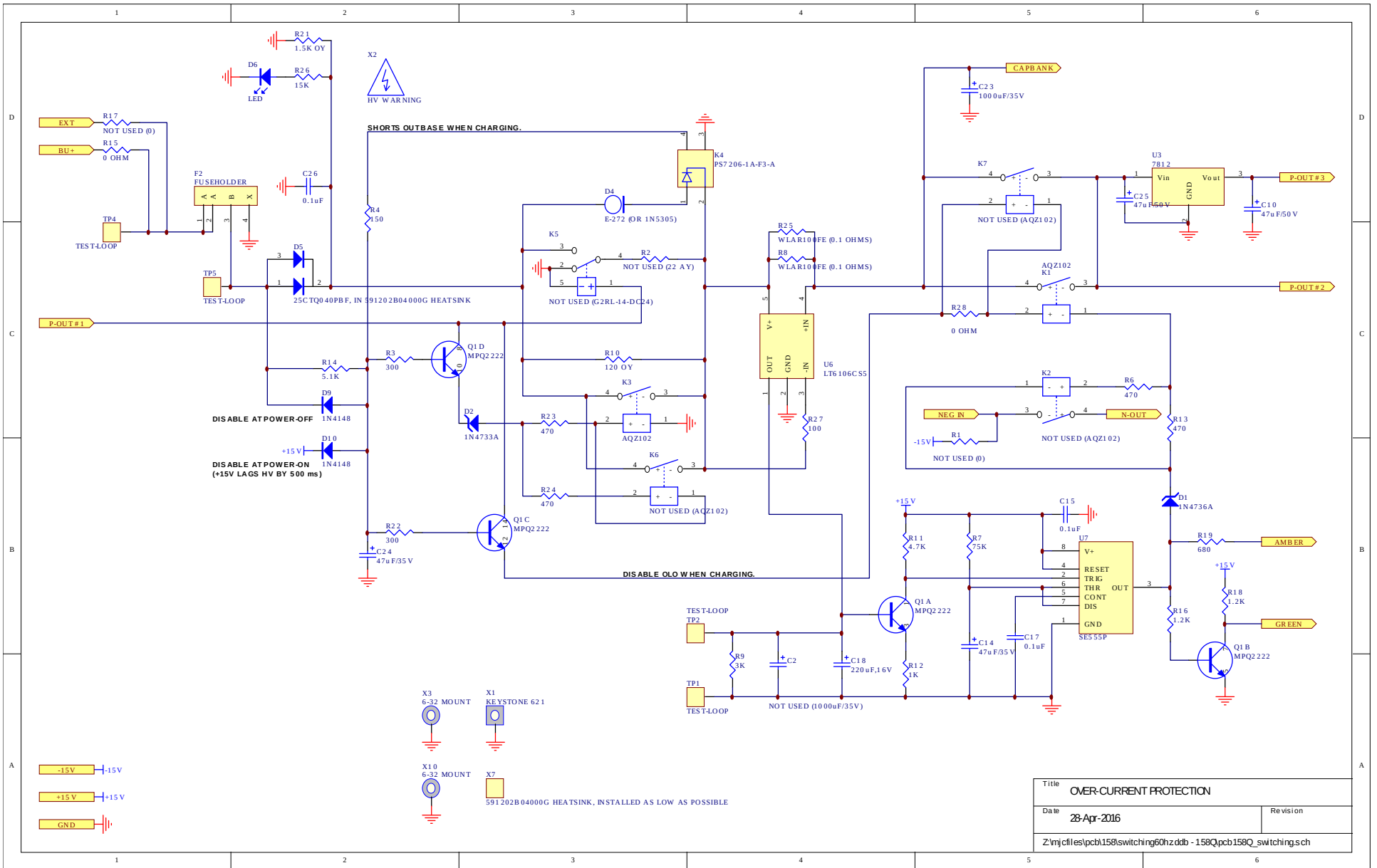

# PCB 104F - KEYPAD / DISPLAY BOARD, 1/3

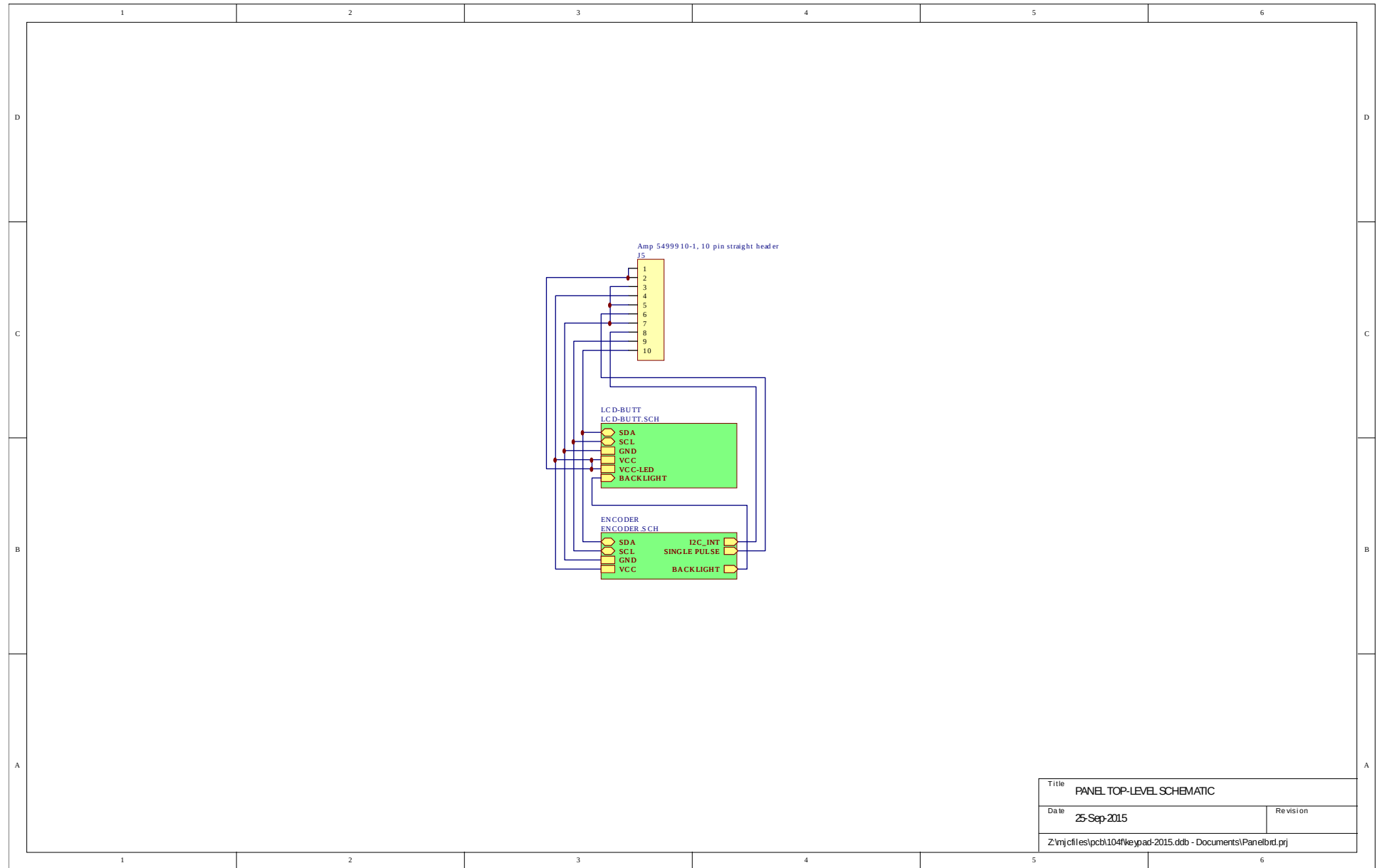

# PCB 104F - KEYPAD / DISPLAY BOARD, 2/3

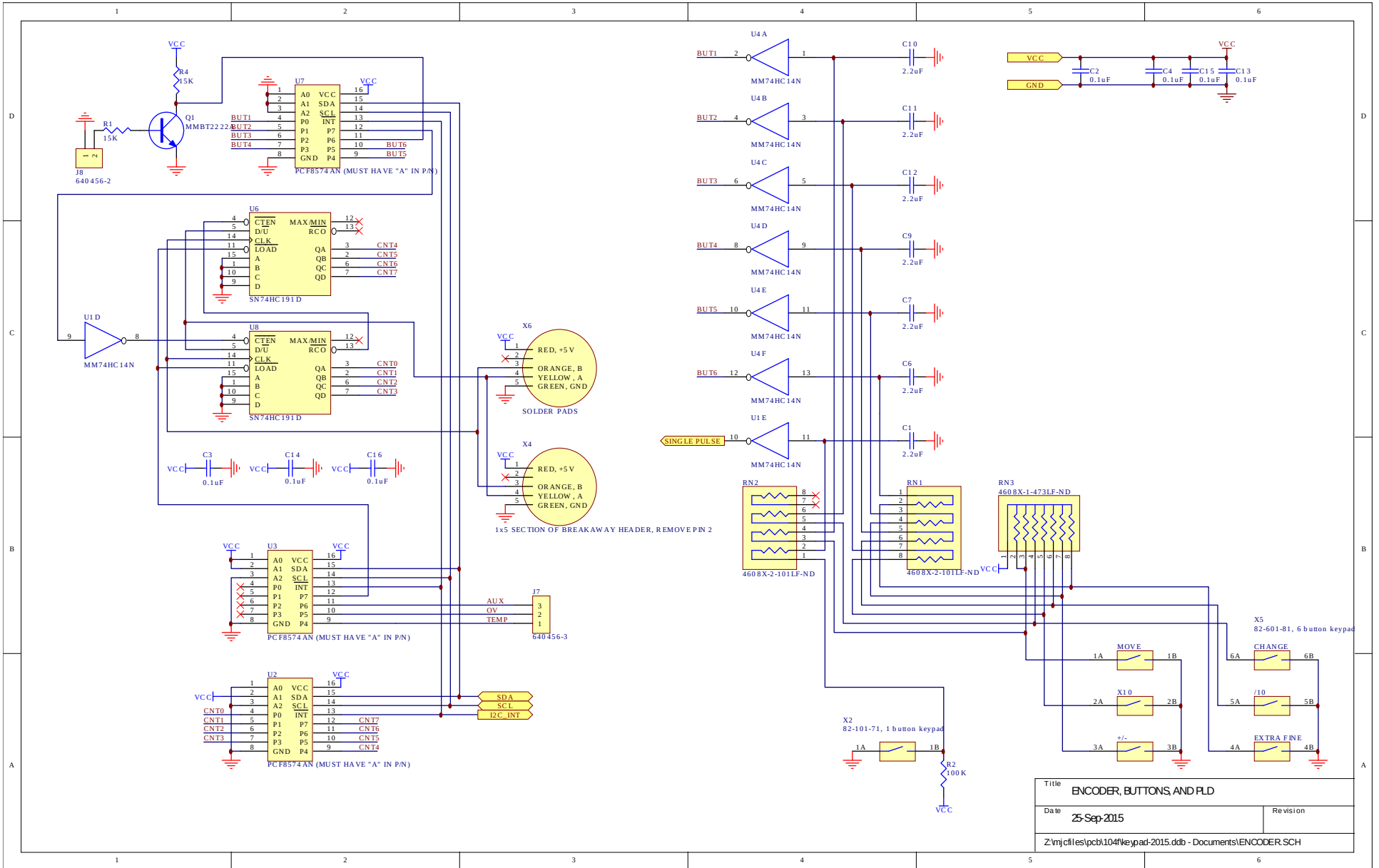

# PCB 104F - KEYPAD / DISPLAY BOARD, 3/3

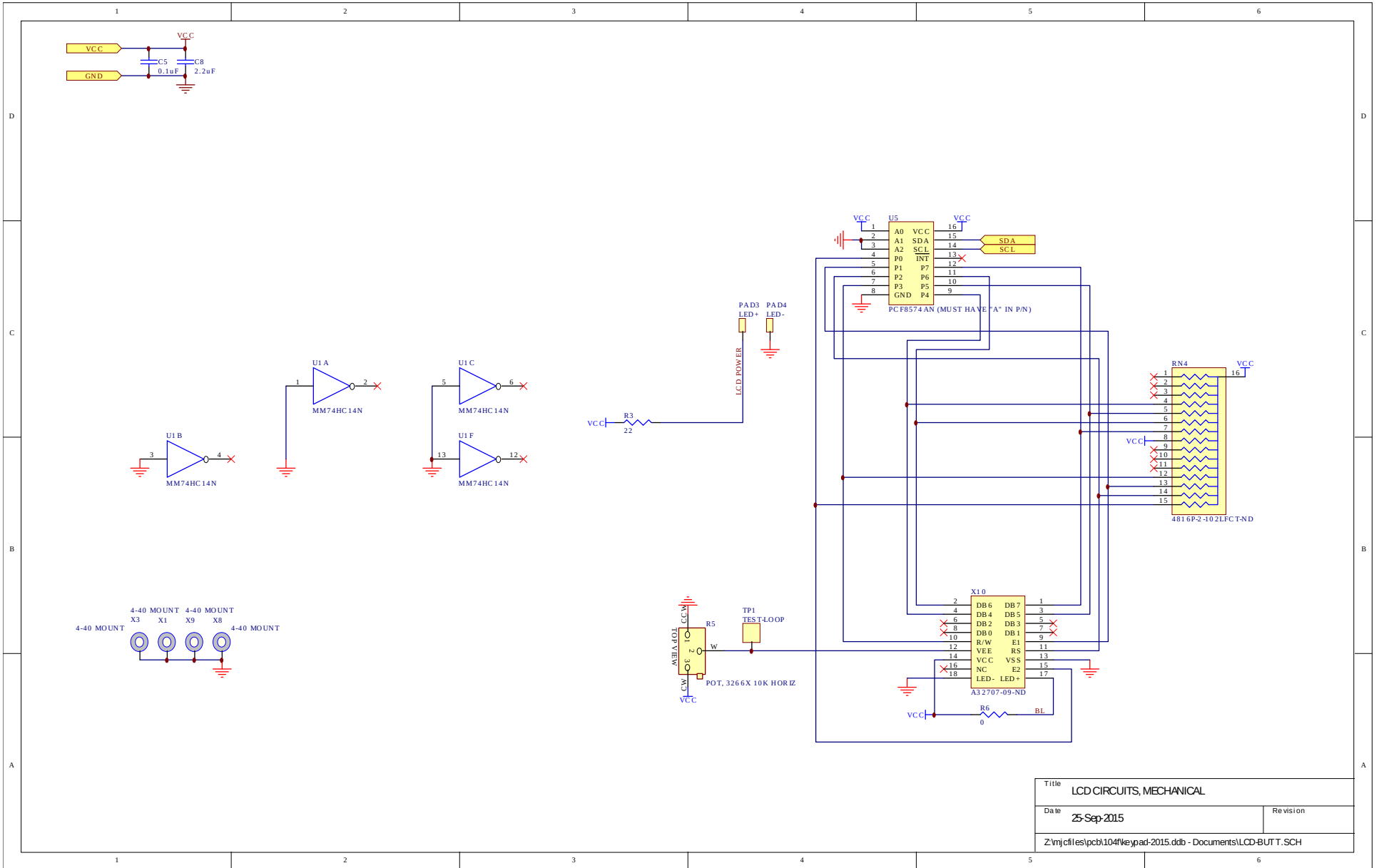

Title		LCD CIRCUITS, MECHANICAL	
Date	25-Sep-2015	Revision	
Z:\njcf\es\pcb\104f\keypad-2015.ddb - Documents\LCD-BUT.T.SCH			

# PCB 116D - CURRENT MONITOR

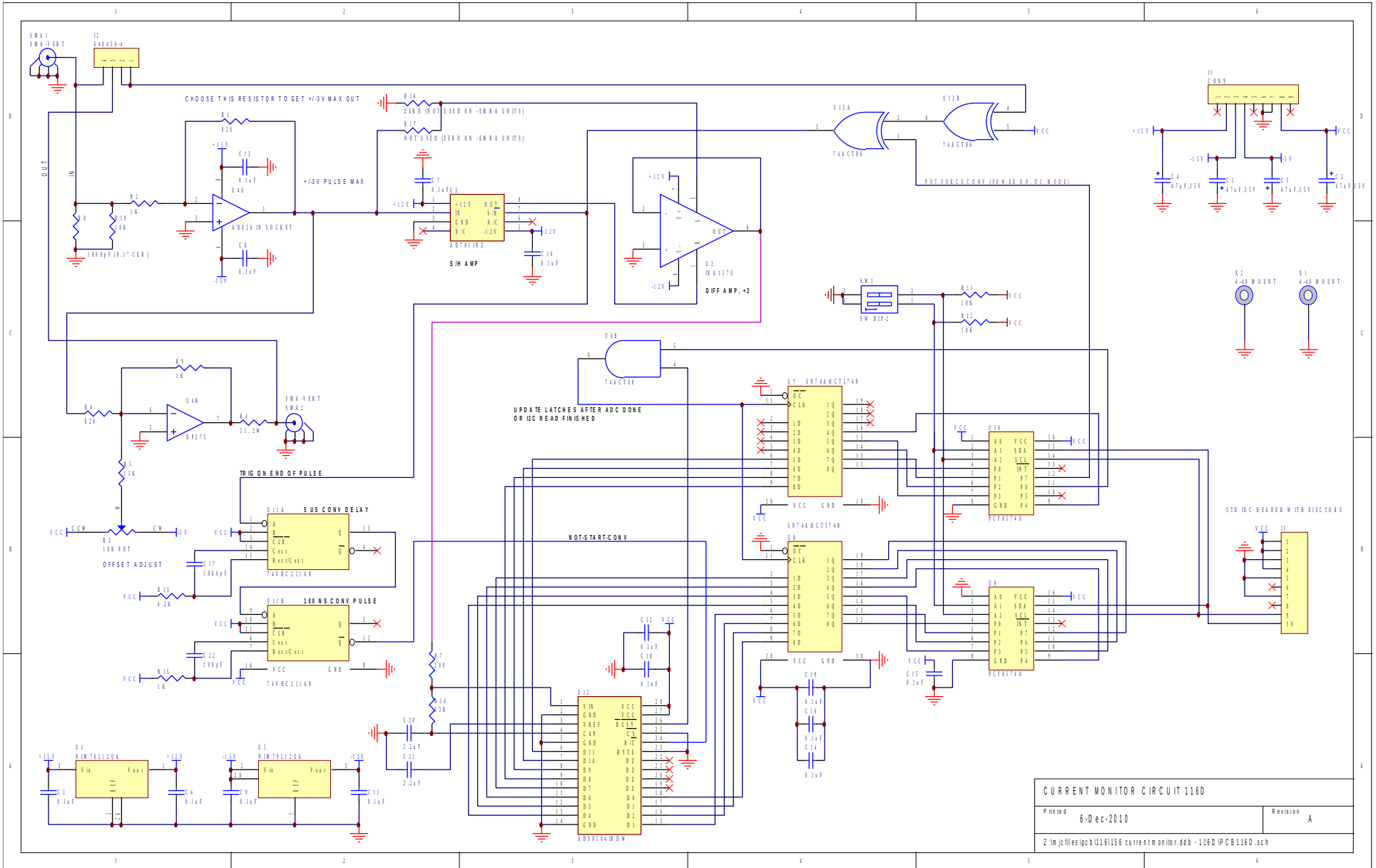

# PCB 94G - ALARM BOARD

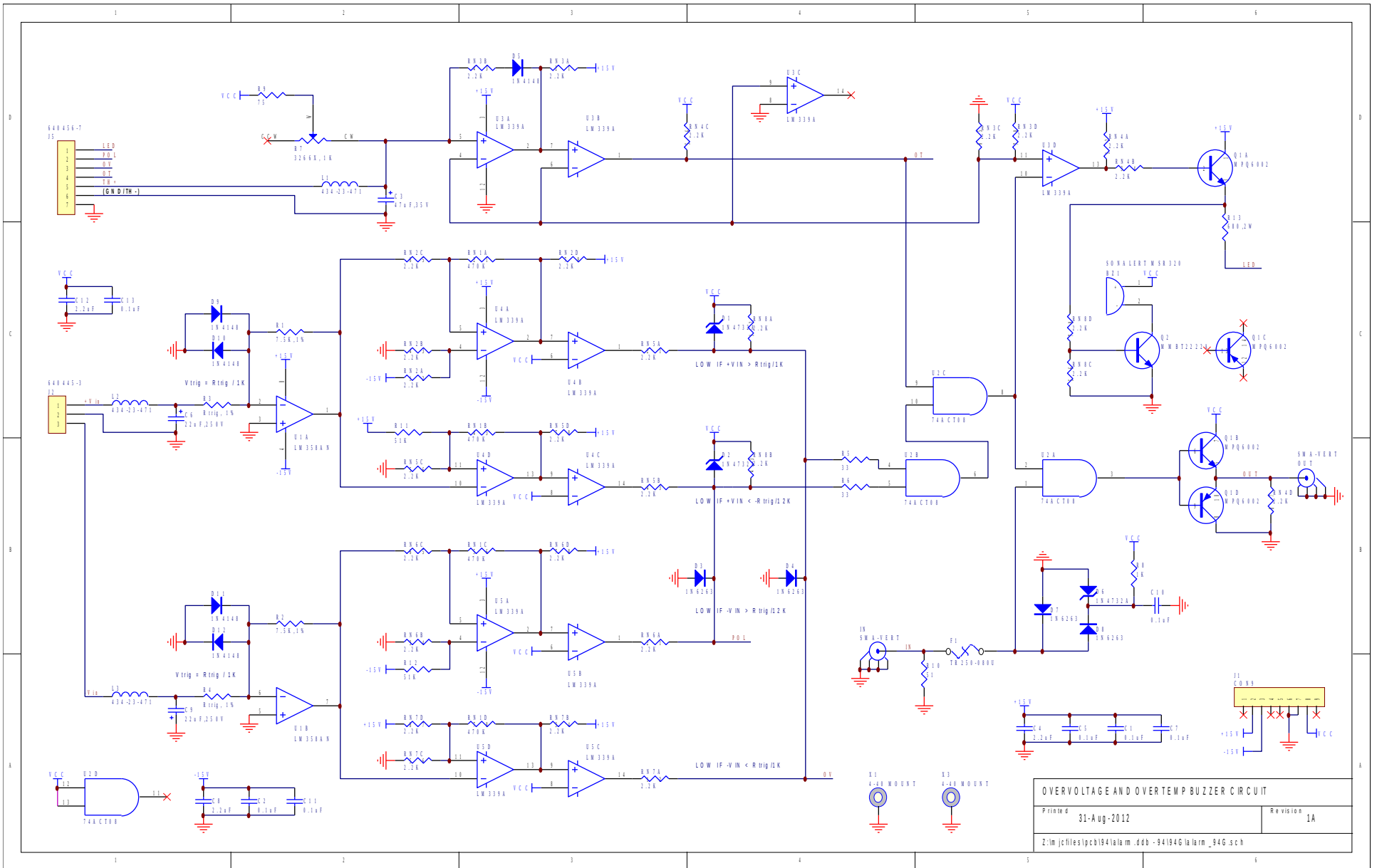



# PCB 288A - SAFE OPERATING AREA PROTECTION

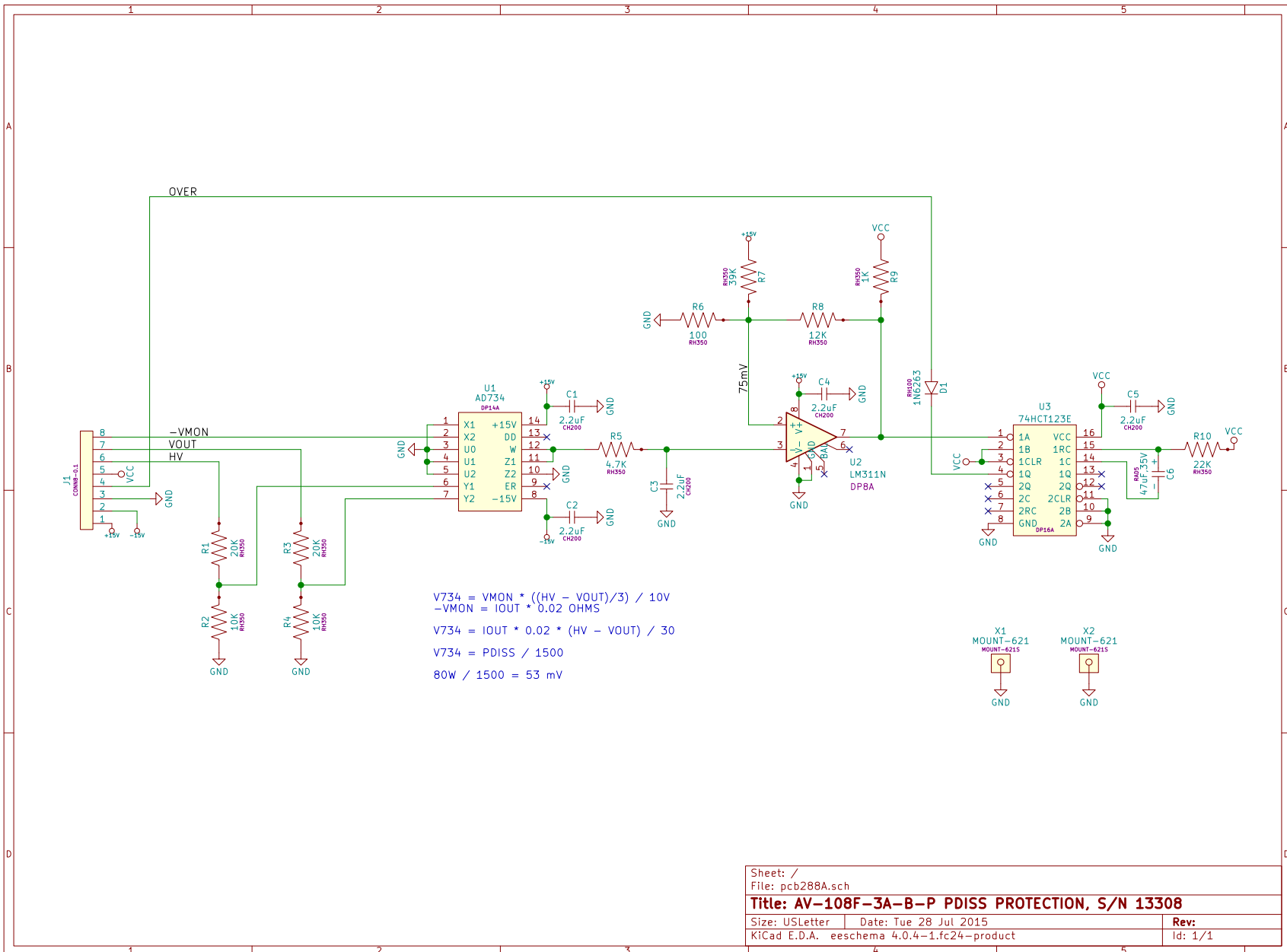

# MAIN WIRING

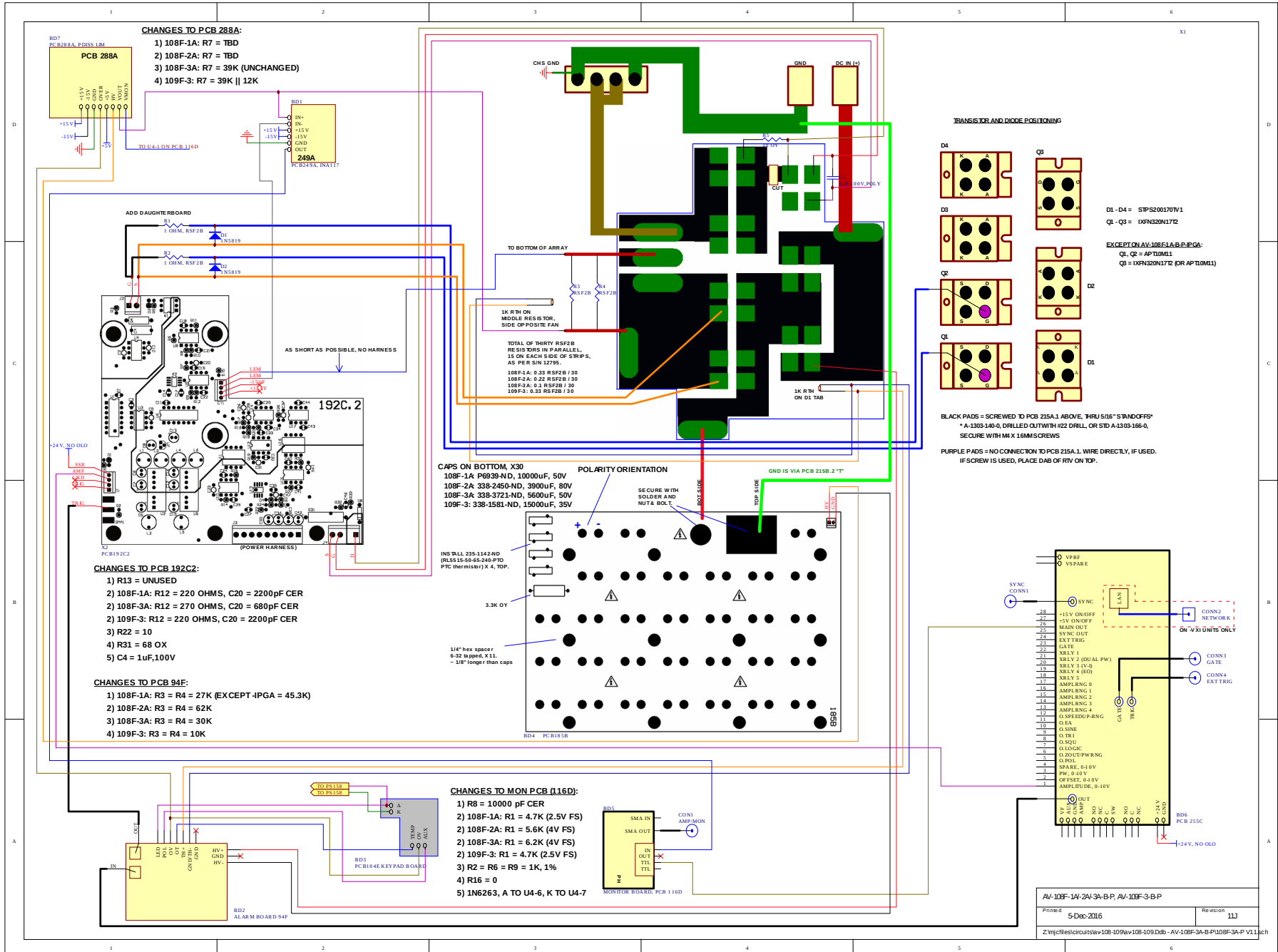

PERFORMANCE CHECK SHEET