



AVTECH ELECTROSYSTEMS LTD.

NANOSECOND WAVEFORM ELECTRONICS
SINCE 1975

P.O. BOX 265
OGDENSBURG, NY
U.S.A. 13669-0265
TEL: (315) 472-5270
FAX: (613) 226-2802

TEL: 1-800-265-6681
FAX: 1-800-561-1970

e-mail: info@avtechpulse.com
<http://www.avtechpulse.com/>

BOX 5120, LCD MERIVALE
OTTAWA, ONTARIO
CANADA K2C 3H4
TEL: (613) 226-5772
FAX: (613) 226-2802

INSTRUCTIONS

MODEL AV-131B-141C1-BNC-PS

BENCH-TOP

TWO-STAGE AMPLIFIER

SERIAL NUMBER: _____

WARRANTY

Avtech Electrosystems Ltd. warrants products of its manufacture to be free from defects in material and workmanship under conditions of normal use. If, within one year after delivery to the original owner, and after prepaid return by the original owner, this Avtech product is found to be defective, Avtech shall at its option repair or replace said defective item. This warranty does not apply to units which have been disassembled, modified or subjected to conditions exceeding the applicable specifications or ratings. This warranty is the extent of the obligation assumed by Avtech with respect to this product and no other warranty or guarantee is either expressed or implied.

TECHNICAL SUPPORT

Phone: 613-226-5772 or 1-800-265-6681

Fax: 613-226-2802 or 1-800-561-1970

E-mail: info@avtechpulse.com

World Wide Web: <http://www.avtechpulse.com>

TABLE OF CONTENTS

WARRANTY.....2

TECHNICAL SUPPORT.....2

TABLE OF CONTENTS.....3

INTRODUCTION.....4

SPECIFICATIONS - AV-131B.....5

SPECIFICATIONS - AV-141C1.....5

SPECIFICATIONS - AV-131B-141C1-BNC-PS.....5

ORIGINAL QUOTATION.....6

INSTALLATION.....7

VISUAL CHECK.....7

PLUGGING IN THE INSTRUMENT.....7

FRONT PANEL CONTROLS.....9

REAR PANEL CONTROLS..... 10

BASIC TEST ARRANGEMENT..... 11

TYPICAL WAVEFORMS..... 12

PROTECTING YOUR INSTRUMENT..... 13

MECHANICAL INFORMATION..... 14

TOP COVER REMOVAL..... 14

ELECTROMAGNETIC INTERFERENCE..... 14

MAINTENANCE..... 14

REGULAR MAINTENANCE..... 14

CLEANING..... 14

POWER SUPPLY AND FUSE REPLACEMENT..... 15

Manual Reference: /files/officefiles/instructword/av-130/AV-131B-141C1-BNC-PS,edition1.sxw.
 Last modified February 29, 2024.
 Copyright © 2024 Avtech Electrosystems Ltd, All Rights Reserved.

INTRODUCTION

The AV-131B-141C1-BNC-PS instrument consists of an Avtech AV-131B pulse amplifier and an Avtech AV-141C1 amplifier, packaged in an AC-powered bench-top chassis. The two amplifier stages are independent.

The AV-131B amplifier has a gain of 40 dB (100 V/V) approximately, with a rise time of 1 ns or less. The maximum input is 10 mV, and the maximum output is 1V. The AV-131B stage is inverting. The input and output of the AV-131B are AC-coupled.

The AV-141C1 amplifier has a gain of 20 dB (10 V/V) approximately, with a rise time of 800 ps or less. The maximum input is 300 mV, and the maximum output is 3V. The AV-141C1 stage is non-inverting. The input and output of the AV-141C1 are DC-coupled.

The input impedance of both amplifiers is 50 Ohms. The AV-131B amplifier requires a 50 Ohm load. The AV-141C1 amplifier can drive loads of 50 Ohms or higher.

This instrument is intended for use in research and development laboratories.

SPECIFICATIONS - AV-131B

Model:	AV-131B
Bandwidth: (3 dB)	1-500 MHz
Gain: in dB:	40 dB
voltage gain (V/V):	0
Rise, fall time:	1.0 ns
Input impedance:	50 Ohms
Peak output: (to 50 Ω)	1 V
P _{1dB} power out at 1 dB gain compression:	18 dBm
1P ₃ third order intercept point:	28 dBm
Noise figure:	3 dB
Voltage equivalent:	16 μ V
Min. input pulse width:	1 ns
Max. input pulse width:	500 ns

SPECIFICATIONS - AV-141C1

Model:	AV-141C1
Bandwidth:	DC - 800 MHz
Gain: in dB:	20 dB
voltage gain (V/V):	$\times 10$
Rise/fall time ¹ :	800 ps
Input impedance:	50 Ω
Peak output: (to 50 Ω)	± 3 V
Output impedance:	3 Ω , approx.
Min. input pulse width:	1.5 ns
Max. input pulse width:	No limit.
Equivalent input noise:	4 nV / $\sqrt{\text{Hz}}$

1) Measured for a pulse from 0V to maximum positive voltage output, between the 20% and 80% amplitude points.

SPECIFICATIONS - AV-131B-141C1-BNC-PS

Model:	AV-131B-141C1-BNC-PS
Connectors:	BNC
Power requirement:	120 / 240 Volts (switchable), 50 - 60 Hz
Dimensions (H x W x D):	100 mm x 215 mm x 375 mm (3.9" x 8.5" x 14.8")
Chassis material:	Anodized aluminum, with blue plastic trim.
Mounting:	Any
Temperature range:	+5°C to +40°C

ORIGINAL QUOTATION

May 6, 2004
 To: Matthias Geissel
 Sandia Natl. Lab.
 505-284-1912
 mgeisse@sandia.gov

Matthias,

In response to our phone conversation, I am pleased to re-quote as follows:

Quote number: 12070

Model number: AV-131B-141C1-BNC-PS

Description: Two-Stage Pulse Amplifier. This AC-powered chassis contains two independent amplifier modules, with independent inputs and outputs.

Amplifier #1: AV-131B (see <http://www.avtechpulse.com/ac-linear/av-131b>)

Amplifier #2: AV-141C1 (see <http://www.avtechpulse.com/linear/av-141c1>)

Connectors: Four BNC connectors (one input and one output for each amplifier).

Note: The AV-131B stage can safely withstand inputs of +/- 100 mV.

Price: \$2498 US each, FOB destination.

Estimated delivery: 60 days after receipt of order.

Please call or email me if I can be of further assistance.

Regards,
 Dr. Michael J. Chudobiak
 Chief Engineer

--- Avtech Electrosystems Ltd. ----- since 1975 ---

PO Box 265	ph: 1-800-265-6681 or 613-226-5772	Box 5120,
Ogdensburg,	fax: 1-800-561-1970 or 613-226-2802	LCD Merivale
New York	email: info@avtechpulse.com	Ottawa, Ontario
USA 13669-0265	http://www.avtechpulse.com/	Canada K2C 3H4

Nanosecond Waveform Generators
 for general purpose, R&D and OEM applications

Pulse Generators - Laser Diode Drivers - Pulse Amplifiers
 Impulse Generators - Current Pulsers - Delay Generators - Splitters
 Function Generators - Monocycle Generators - Frequency Dividers + more!

INSTALLATION

VISUAL CHECK

After unpacking the instrument, examine to ensure that it has not been damaged in shipment. Visually inspect all connectors, knobs, and handles. Confirm that a power cord is with the instrument. If the instrument has been damaged, file a claim immediately with the company that transported the instrument.

PLUGGING IN THE INSTRUMENT

Examine the rear of the instrument. There will be a male power receptacle, a fuse holder and the edge of the power selector card visible. Confirm that the power selector card is in the correct orientation.

For AC line voltages of 110-120V, the power selector card should be installed so that the “120” marking is visible from the rear of the instrument, as shown below:



For AC line voltages of 220-240V, the power selector card should be installed so that the “240” marking is visible from the rear of the instrument, as shown below:



If it is not set for the proper voltage, remove the fuse and then grasp the card with a pair of pliers and remove it. Rotate horizontally through 180 degrees. Reinstall the card and the correct fuse.

In the 120V setting, a 0.25A slow blow fuse is required. In the 240V setting, a 0.125A slow blow fuse is required.

FRONT PANEL CONTROLS

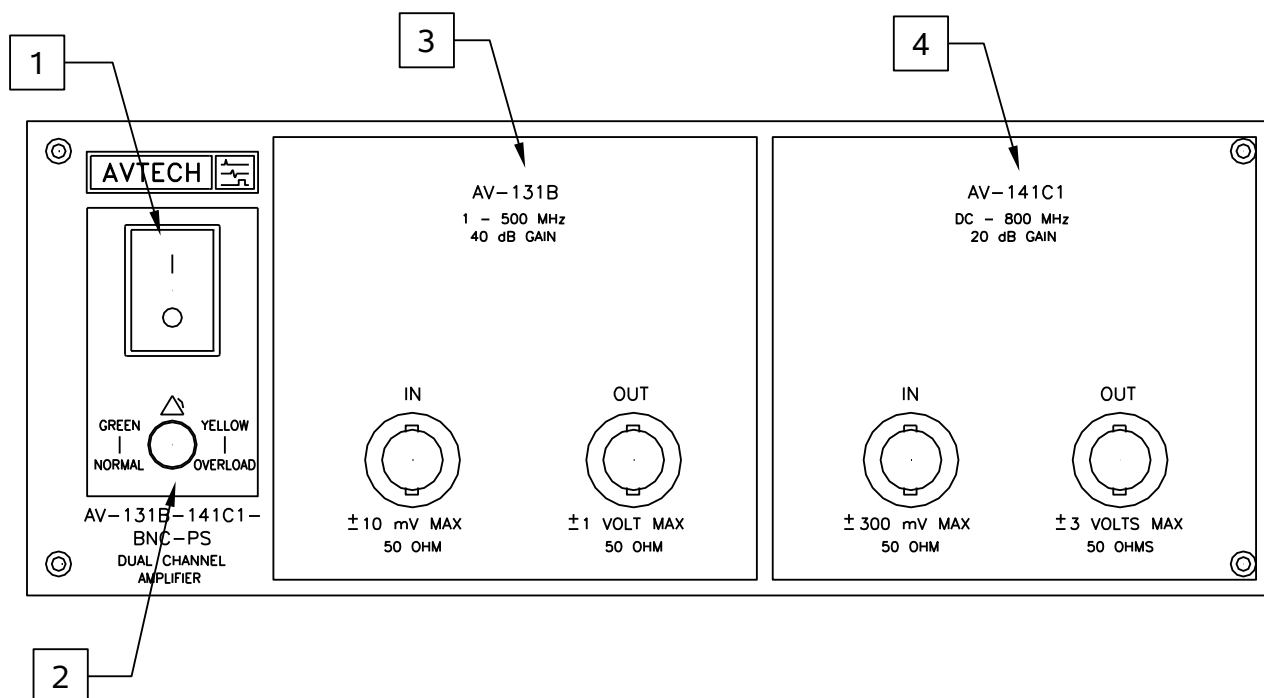

- 1) POWER Switch. This is the main power switch. When turning the instrument on, there may be a delay of several seconds before the instrument appears to respond.
- 2) OVERLOAD Indicator. When the instrument is powered, this indicator is normally green, indicating normal operation. If this indicator is yellow, an internal automatic overload protection circuit has been tripped. If the unit is overloaded (by operating at an exceedingly high duty cycle or by operating into a very low impedance), the protective circuit will disable the output of the instrument and turn the indicator light yellow. The light will stay yellow (i.e. output disabled) for about 5 seconds after which the instrument will attempt to re-enable the output (i.e. light green) for about 1 second. If the overload condition persists, the output will be disabled again (i.e. light yellow) for another 5 seconds. If the overload condition has been removed, the instrument will resume normal operation.

This overload indicator may flash yellow briefly at start-up. This is not a cause for concern.

Note that the output stage will safely withstand a short-circuited load condition.

- 3) AV-131B Amplifier. These are the input and output connectors for the AV-131B amplifier.
- 4) AV-141C1 Amplifier. These are the input and output connectors for the AV-141C1 amplifier.

REAR PANEL CONTROLS

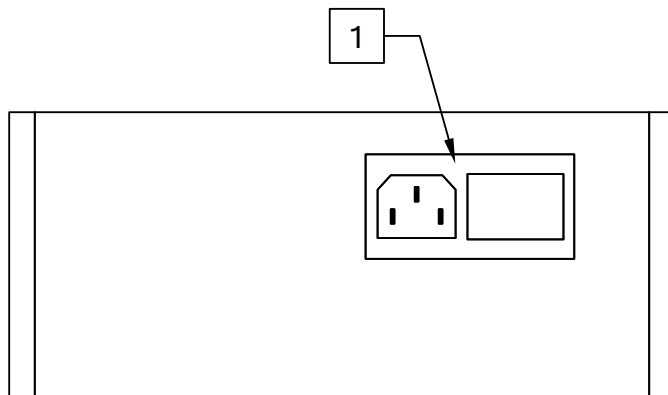

1. AC POWER INPUT. A three-pronged recessed male connector is provided on the back panel for AC power connection to the instrument. Also contained in this assembly is a slow-blow fuse and a removable card that can be removed and repositioned to switch between 120V AC in and 240V AC in.

For AC line voltages of 110-120V, the power selector card should be installed so that the “120” marking is visible from the rear of the instrument.

For AC line voltages of 220-240V, the power selector card should be installed so that the “240” marking is visible from the rear of the instrument.

If it is not set for the proper voltage, remove the fuse and then grasp the card with a pair of pliers and remove it. Rotate horizontally through 180 degrees. Reinstall the card and the correct fuse.

In the 120V setting, a 0.25A slow blow fuse is required. In the 240V setting, a 0.125A slow blow fuse is required. See the “Installation” section for more details.

BASIC TEST ARRANGEMENT

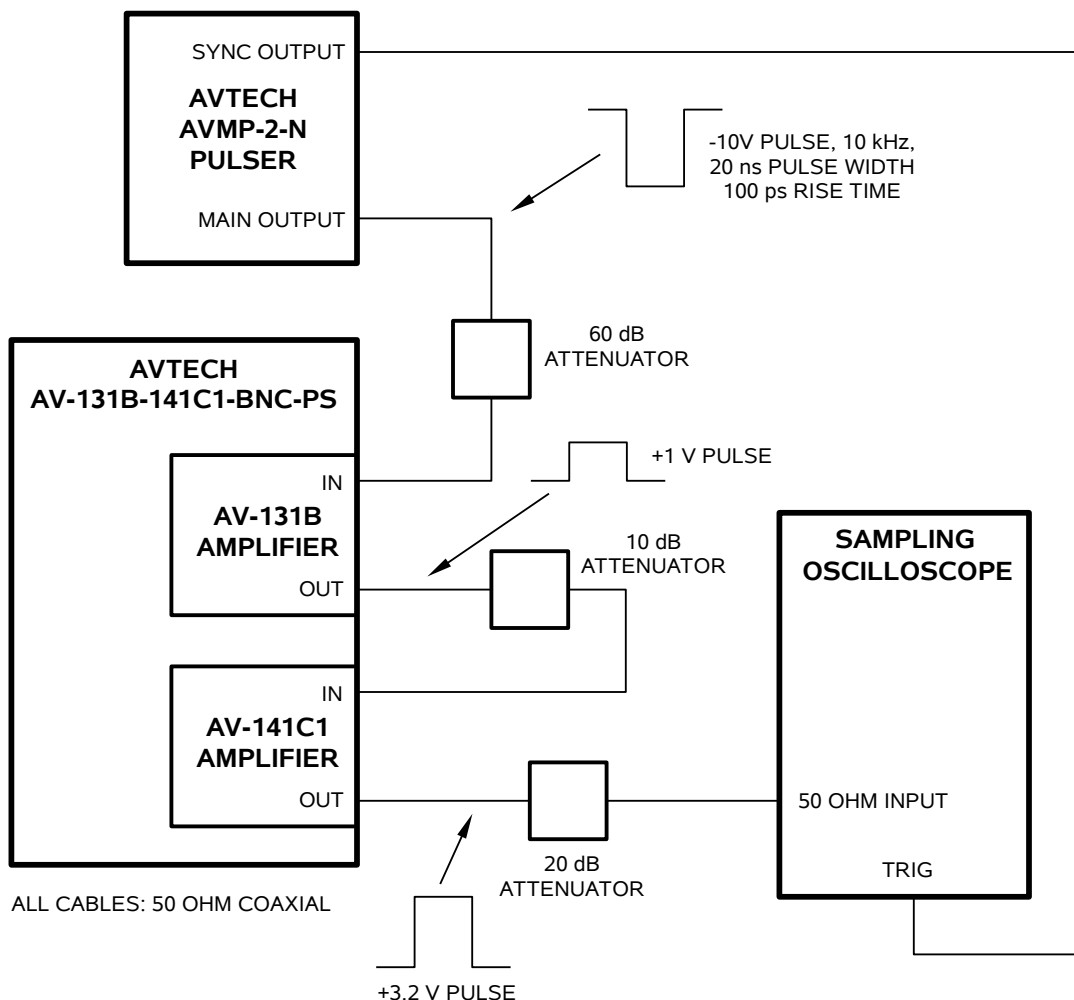

The test set-up used at the factory is shown above.

The Avtech AVMP-2-N series can be used to generate a -10V pulse at 10 kHz, with 20 ns pulse width. The rise time will be 100 ps. The 60 dB attenuator will reduce this signal to -10 mV.

The AV-131B amplifier will amplify the signal to +1V ($10 \text{ mV} \times 40 \text{ dB}$, with inversion). The output rise time should be 1 ns or less. (Note that if a slower input signal is used, the observed output signal will be correspondingly slower.)

A 10 dB attenuator is placed on the output of the AV-131B, to avoid over-driving the input of the AV-141C1.

The AV-141C1 amplifier will amplify the signal to 3.2V ($+1\text{V} \times (20 \text{ dB} - 10 \text{ dB})$).

A 20 dB attenuator should be placed at the input of the oscilloscope, to avoid over-driving the input. Most high-bandwidth sampling oscilloscopes do not tolerate inputs of more than $\pm 1\text{V}$.

The bandwidth capability of components and instruments used to display the pulse generator output signal (attenuators, cables, connectors, etc.) should exceed several gigahertz.

TYPICAL WAVEFORMS

With the above test arrangement, the following waveform was obtained:

2 V/div, 5 ns/div.

This shows a +3.2V pulse from the output of the AV-131B-141C1-BNC-PS (attenuated by a 20 dB attenuator on the input of the oscilloscope).

PROTECTING YOUR INSTRUMENT

 To obtain maximum performance, the inputs of the AV-131B-141C1-BNC-PS are not protected against excessive input voltages. The input signals **MUST NOT EXCEED ± 300 mV!** It may be damaged by voltages greater than ± 300 mV. Failures due to the application of excessive input voltages are not covered by warranty.

MECHANICAL INFORMATION

TOP COVER REMOVAL

If necessary, the interior of the instrument may be accessed by removing the four Phillips screws on the top panel. With the four screws removed, the top cover may be slid back (and off).

Always disconnect the power cord before opening the instrument.

There are no user-adjustable internal circuits. For repairs other than fuse replacement, please contact Avtech (info@avtechpulse.com) to arrange for the instrument to be returned to the factory for repair.



Caution: High voltages are present inside the instrument during normal operation. Do not operate the instrument with the cover removed.

ELECTROMAGNETIC INTERFERENCE

To prevent electromagnetic interference with other equipment, all used outputs should be connected to shielded 50Ω loads using shielded 50Ω coaxial cables. Unused outputs should be terminated with shielded 50Ω coaxial terminators or with shielded coaxial dust caps, to prevent unintentional electromagnetic radiation. All cords and cables should be less than 3m in length.

MAINTENANCE

REGULAR MAINTENANCE

This instrument does not require any regular maintenance.

CLEANING

If desired, the interior of the instrument may be cleaned using compressed air to dislodge any accumulated dust. (See the “TOP COVER REMOVAL” section for instructions on accessing the interior.) No other cleaning is recommended.

POWER SUPPLY AND FUSE REPLACEMENT

This instrument has three main fuses, plus two spares. One, which protects the AC input, is located in the rear-panel power entry module, as described in the “Rear Panel Controls” section of this manual. If the power appears to have failed, check the AC fuse first.

The other two fuses (plus two spares) are located on the internal DC power supply, as shown below:

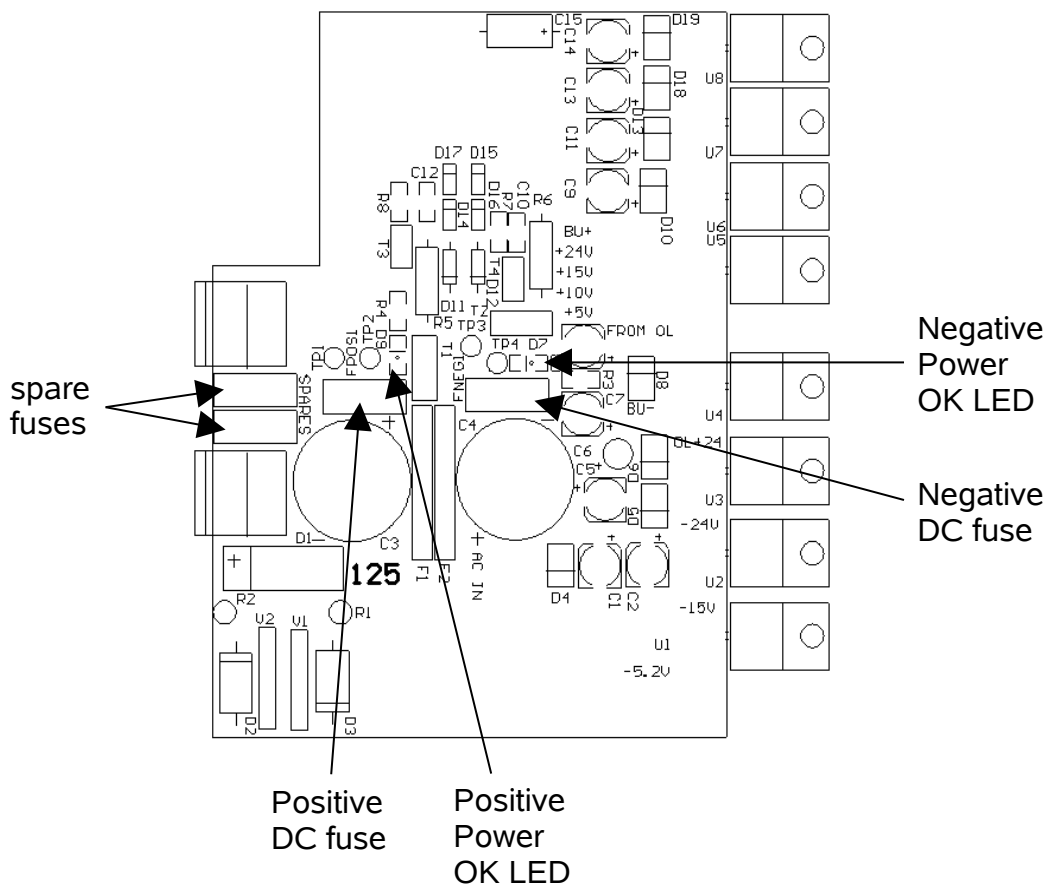

The four fuses on this circuit board are 0.5A slow-blow fuses, Littlefuse part number R452.500. (This fuse can be ordered from Digikey, www.digikey.com. The Digikey part number is F1341CT-ND).

If you suspect that the DC fuses are blown, follow this procedure:

1. Remove the top cover, by removing the four Phillips screws on the top cover and then sliding the cover back and off.
2. Locate the two “Power OK” LEDs on the power supply circuit board, as illustrated above.

3. Turn on the instrument.
4. Observe the “Power OK” LEDs. If the fuses are not blown, the two LEDs will be lit (bright red). If one of the LEDs is not lit, the fuse next to it has blown.
5. Turn off the instrument.
6. If a fuse is blown, use needle-nose pliers to remove the blown fuse from its surface-mount holder.
7. Replace the fuse. (Two spare 0.5 Amp fuses are provided on the circuit board. They may be transferred to the active fuse locations using needle-nose pliers.)