



AVTECH ELECTROSYSTEMS LTD.

NANOSECOND WAVEFORM ELECTRONICS
SINCE 1975

P.O. BOX 265
OGDENSBURG, NY
U.S.A. 13669-0265
TEL: (315) 472-5270
FAX: (613) 226-2802

TEL: 1-800-265-6681
FAX: 1-800-561-1970

e-mail: info@avtechpulse.com
<http://www.avtechpulse.com/>

BOX 5120, LCD MERIVALE
OTTAWA, ONTARIO
CANADA K2C 3H4
TEL: (613) 226-5772
FAX: (613) 226-2802

INSTRUCTIONS

MODEL AV-141J
×1 GAIN, ±10V OUTPUT
PULSE AMPLIFIER
WITH 10 ns RISE AND FALL TIMES

SERIAL NUMBER: _____

WARRANTY

Avtech Electrosystems Ltd. warrants products of its manufacture to be free from defects in material and workmanship under conditions of normal use. If, within one year after delivery to the original owner, and after prepaid return by the original owner, this Avtech product is found to be defective, Avtech shall at its option repair or replace said defective item. This warranty does not apply to units which have been disassembled, modified or subjected to conditions exceeding the applicable specifications or ratings. This warranty is the extent of the obligation assumed by Avtech with respect to this product and no other warranty or guarantee is either expressed or implied.

TECHNICAL SUPPORT

Phone: 613-226-5772 or 1-800-265-6681

Fax: 613-226-2802 or 1-800-561-1970

E-mail: info@avtechpulse.com

World Wide Web: <http://www.avtechpulse.com>

TABLE OF CONTENTS

WARRANTY.....2

TECHNICAL SUPPORT.....2

TABLE OF CONTENTS.....3

INTRODUCTION.....4

SPECIFICATIONS.....4

EUROPEAN REGULATORY NOTES.....5

EC DECLARATION OF CONFORMITY.....5

DIRECTIVE 2002/95/EC (RoHS).....5

CONTROLS.....6

POWER SUPPLIES.....6

PROTECTING YOUR INSTRUMENT.....6

BASIC TEST ARRANGEMENT.....7

PERFORMANCE CHECK SHEET.....8

Manual Reference: /filesserver1/officefiles/instructword/av-141/OBS/av-141j, edition3.sxw.
Last modified February 29, 2024.
Copyright © 2024 Avtech Electrosystems Ltd, All Rights Reserved.

INTRODUCTION

The Model AV-141J is a DC-powered unity-gain pulse amplifier module. The input and output can operate to $\pm 10\text{V}$. The input impedance is $> 1\text{ M}\Omega$, and the output can drive loads as low as 50 Ohms .

SPECIFICATIONS

Model:	AV-141J
Bandwidth:	DC - 50 MHz
Gain: in dB:	0 dB
voltage gain (V/V):	$\times 1$
Rise/fall time ¹ :	10 ns
Input impedance:	$50\ \Omega$
Peak output: (to $50\ \Omega$)	$\pm 10\text{ V}$
Output impedance:	$3\ \Omega$, approx.
Min. input pulse width:	20 ns
Max. input pulse width:	No limit.
Equivalent input noise:	$6\text{ nV} / \sqrt{\text{Hz}}$
Connectors:	SMA
Prime power:	$\pm 24\text{V}$, 200 mA
Dimensions:	1.4" x 1.1" x 2.3"

1) Measured for a pulse from 0V to maximum positive voltage output, between the 20% and 80% amplitude points.

EUROPEAN REGULATORY NOTES

EC DECLARATION OF CONFORMITY

We

Avtech Electrosystems Ltd.
P.O. Box 5120, LCD Merivale
Ottawa, Ontario
Canada K2C 3H4

declare that this pulse generator meets the intent of Directive 89/336/EEC for Electromagnetic Compatibility. Compliance pertains to the following specifications as listed in the official Journal of the European Communities:

EN 50081-1 Emission

EN 50082-1 Immunity

and that this pulse generator meets the intent of the Low Voltage Directive 72/23/EEC as amended by 93/68/EEC. Compliance pertains to the following specifications as listed in the official Journal of the European Communities:

EN 61010-1:2001 Safety requirements for electrical equipment for measurement, control, and laboratory use



DIRECTIVE 2002/95/EC (RoHS)

This instrument is exempt from Directive 2002/95/EC of the European Parliament and of the Council of 27 January 2003 on the Restriction of the use of certain Hazardous Substances (RoHS) in electrical and electronic equipment. Specifically, Avtech instruments are considered "Monitoring and control instruments" (Category 9) as defined in Annex 1A of Directive 2002/96/EC. The Directive 2002/95/EC only applies to Directive 2002/96/EC categories 1-7 and 10, as stated in the "Article 2 - Scope" section of Directive 2002/95/EC.

CONTROLS

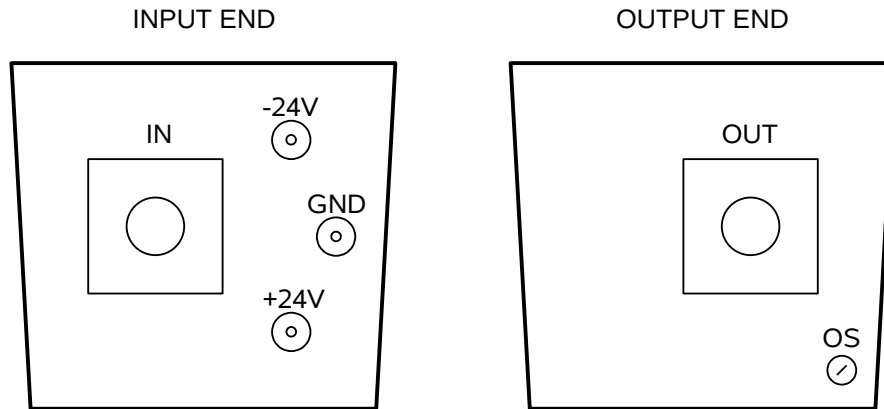

The input and output SMA connectors are located on opposite ends of the module, as shown above.

The +24V, -24V, and GND input solder terminals are located on the input end.

A DC offset nulling trimpot is accessible from the output end. It may be adjusted using a small screwdriver.

POWER SUPPLIES

The AV-141J must be supplied with DC power supplies of nominally +24V and -24V (as well as a ground connection). In practice, the supplies may be as low as $\pm 18V$. The DC power supplies are internally regulated.

The power supply inputs are protected from excessive voltages and incorrect polarities by externally-mounted (and replaceable) 1N4750A Zener diodes. These diodes may be damaged by reversed polarities, or voltages exceeding $\pm 27V$.

PROTECTING YOUR INSTRUMENT

The input and output circuits do contain some over-voltage protection circuitry. However, failures due to the application of excessive input voltages ($> \pm 10V$) are not covered by warranty.

The internal power dissipation rises at high duty cycles. If possible, avoid operating with duty cycles above 50% when operating near the maximum output amplitude ($\pm 10V$), to maximize lifetime.

BASIC TEST ARRANGEMENT

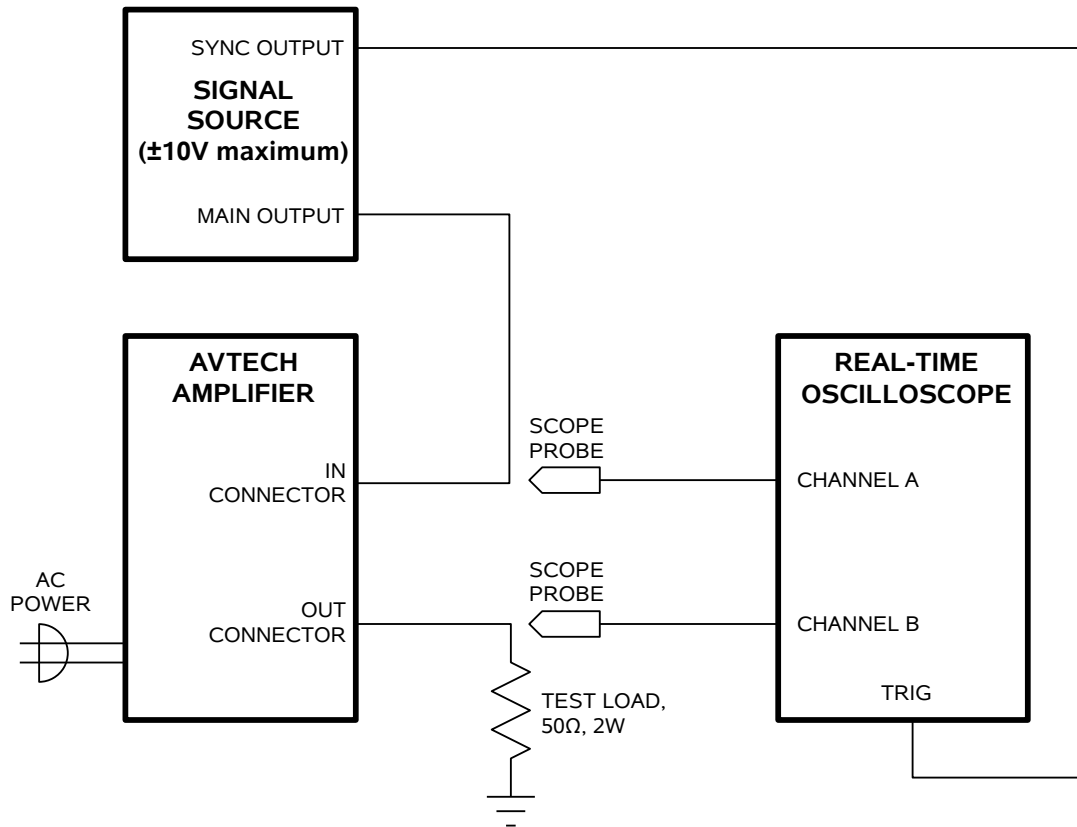

The recommended test set-up is shown above. The Avtech AV-1000-C pulse generator is a suitable signal source.

The bandwidth capability of components and instruments used to display the pulse generator output signal (attenuators, cables, connectors, etc.) should exceed 200 MHz.

PERFORMANCE CHECK SHEET