

INSTRUCTIONS

MODEL AV-143B-PS

0 to $\pm 4V$ IN,

0 to $\pm 20V$ OUT, TO 50 OHMS,

DC-COUPLED LINEAR AMPLIFIER

SERIAL NUMBER: _____

WARRANTY

Avtech Electrosystems Ltd. warrants products of its manufacture to be free from defects in material and workmanship under conditions of normal use. If, within one year after delivery to the original owner, and after prepaid return by the original owner, this Avtech product is found to be defective, Avtech shall at its option repair or replace said defective item. This warranty does not apply to units which have been disassembled, modified or subjected to conditions exceeding the applicable specifications or ratings. This warranty is the extent of the obligation assumed by Avtech with respect to this product and no other warranty or guarantee is either expressed or implied.

TECHNICAL SUPPORT

Phone: 613-226-5772 or 1-800-265-6681

Fax: 613-226-2802 or 1-800-561-1970

E-mail: info@avtechpulse.com

World Wide Web: <http://www.avtechpulse.com>

TABLE OF CONTENTS

WARRANTY	2
TECHNICAL SUPPORT	2
TABLE OF CONTENTS	3
INTRODUCTION	4
SPECIFICATIONS	4
INSTALLATION	5
VISUAL CHECK	5
PLUGGING IN THE INSTRUMENT	5
FRONT PANEL CONTROLS	6
REAR PANEL CONTROLS	8
GENERAL INFORMATION	9
BASIC OPERATION	9
OPERATIONAL CHECK	10
USAGE PRECAUTIONS	11
INTERNAL ADJUSTMENTS	11
POWER SUPPLY AND FUSE REPLACEMENT	12
PERFORMANCE CHECK SHEET	14

INTRODUCTION

The Model AV-143B-PS DC-coupled linear amplifier has a gain (V_{OUT}/V_{IN}) of +5. The input may range from 0 to $\pm 4V$. The input impedance is $1\text{ k}\Omega$. The corresponding output range is 0 to $\pm 20V$, into load impedances of 50Ω or greater.

The output rise and fall times are 50 ns or less.

SPECIFICATIONS

Model:	AV-143B-PS
Output amplitude: (max) ($R_L = 50\ \Omega$)	$\pm 20V$
Voltage Gain:	+5 (non-inverting)
Rise, fall time:	$\leq 50\text{ ns}$
Input impedance ¹ :	$1\text{ k}\Omega$
Output impedance:	2Ω
Bandwidth:	DC-10 MHz
Power out: (max)	4 Watts
Overshoot:	$\leq 6\%$
Prime power ² :	120/240 Volts, 50 - 60 Hz
Connectors:	BNC
Dimensions ² :	100 x 215 x 375 mm (3.9" x 8.5" x 14.8")

INSTALLATION

VISUAL CHECK

After unpacking the instrument, examine to ensure that it has not been damaged in shipment. Visually inspect all connectors, knobs, and handles. Confirm that a power cord and this manual are with the instrument. If the instrument has been damaged, file a claim immediately with the company that transported the instrument.

PLUGGING IN THE INSTRUMENT

Examine the rear of the instrument. There will be a male power receptacle, a fuse holder and the edge of the power selector card visible.

For AC line voltages of 110-120V, the power selector card should be installed so that the "120" marking is visible from the rear of the instrument.

For AC line voltages of 220-240V, the power selector card should be installed so that the "240" marking is visible from the rear of the instrument.

If it is not set for the proper voltage, remove the fuse and then grasp the card with a pair of pliers and remove it. Rotate horizontally through 180 degrees. Reinstall the card and the correct fuse.

In the 120V setting, a 0.5A slow blow fuse is required. In the 240V setting, a 0.25A slow-blow fuse is required.

FRONT PANEL CONTROLS

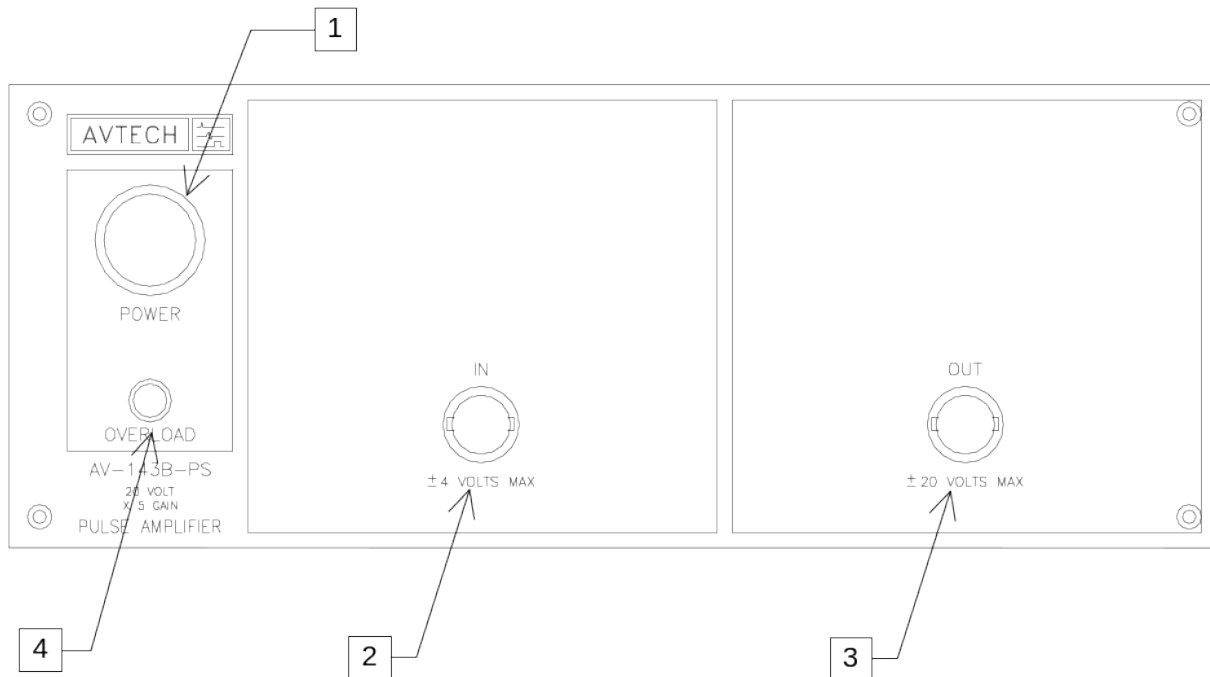

1. **POWER Switch.** The POWER push button switch applies AC prime power to the primaries of the transformer, turning the instrument on. The push button lamp (#382 type) is connected to the +15V DC supply.
2. **IN CONNECTOR.** The input signal to be amplified is applied to this BNC connector. The input should not exceed ± 4 V. The input impedance is 1 k Ω .
3. **OUT CONNECTOR.** This BNC connector provides the main output signal. This output can supply up to ± 20 V into a 50 Ω (or greater) load. The output impedance is approximately 2 Ω .
4. **OVERLOAD.** Units with a serial number higher than 5600 are protected by an automatic overload protective circuit, which controls the front panel overload light. If the unit is overloaded (by operating at an exceedingly high duty cycle or by operating into a short circuit), the protective circuit will turn the output of the instrument OFF and turn the indicator light ON. The light will stay ON (i.e. output OFF) for about 5 seconds after which the instrument will attempt to turn ON (i.e. light OFF) for about 1 second. If the overload condition persists, the instrument will turn OFF again (i.e. light ON) for another 5 seconds. If the overload condition has been removed, the instrument will turn on and resume normal operation. Overload conditions may be removed by:
 - 1) Removing output load short circuit (if any)

- 2) Reducing the output amplitude
- 3) Reducing the output duty cycle (or pulse width)

Note that the overload light may come on when the prime power is applied. The light will extinguish after a few seconds.

REAR PANEL CONTROLS

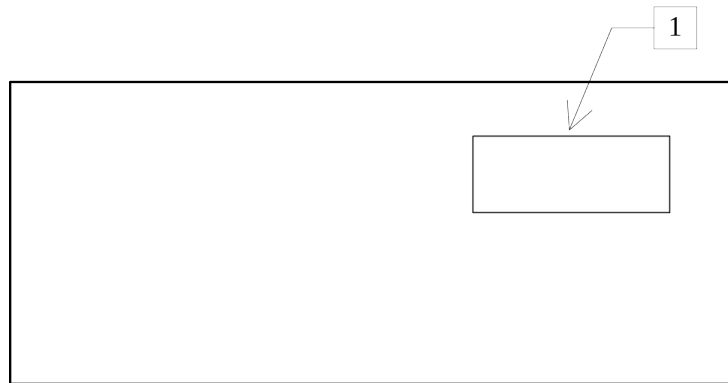

1. AC POWER INPUT. A three-pronged recessed male connector is provided on the back panel for AC power connection to the instrument. Also contained in this assembly is a 0.5A slow blow fuse and a removable card that can be removed and repositioned to switch between 120V AC in and 240V AC in.

GENERAL INFORMATION

BASIC OPERATION

This instrument is very straightforward to connect and operate. There are no adjustable controls used in normal operation. The input signal is connected to the “IN” connector, and the output signal is generated by the amplifier on the “OUT” connector.

The basic test arrangement is shown below:

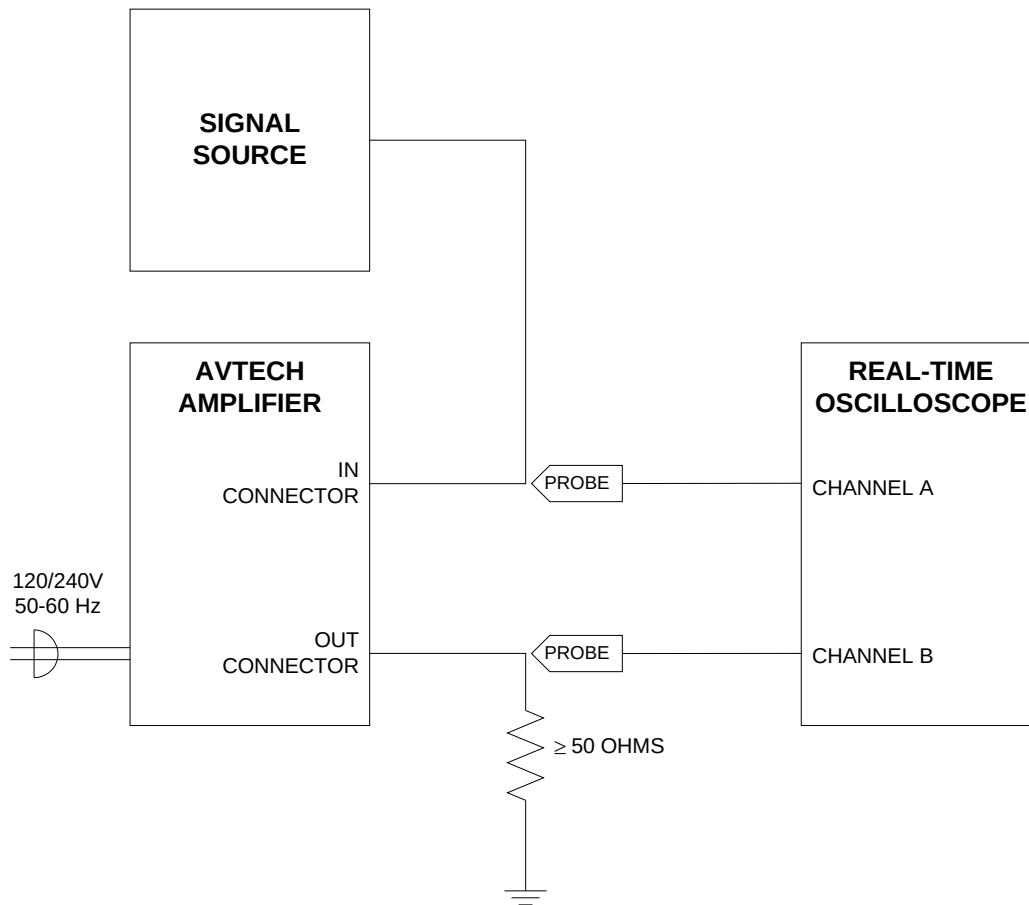

OPERATIONAL CHECK

To confirm the operation of the instrument, connect the amplifier as shown on page 9. Use a signal source capable of generating a 0 to +4V pulse, with rise and fall times of less than 10 ns, and a pulse width of approximately 500 ns. (The Avtech AV-1000-C pulse generator is suitable for this purpose).

Confirm that the oscilloscope properly displays the input signal. Then turn on the Avtech amplifier, and observe the output signal on the oscilloscope. The output amplitude should be approximately +20V, with rise and fall times of 50 ns (when measured between the 20% and 80% amplitude points of each edge).

The waveform below illustrates typical input and output waveforms. The upper waveform is the 0 to +4V input, and the lower waveform is the 0 to +20V output into a 50Ω load.

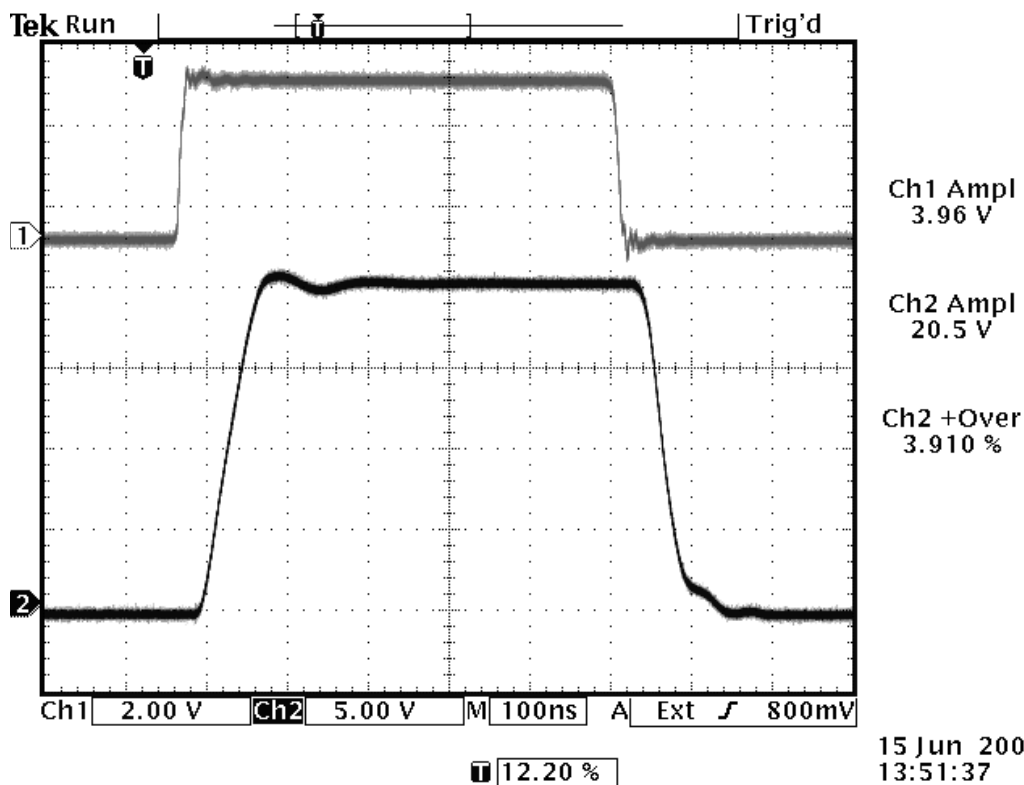

Note that if the rise and fall times of the input signal are longer than 10 ns, the output rise and fall times will increase correspondingly.

If additional assistance is required, contact:

Tel: (613) 226-5772, Fax: (613) 226-2802
 Email: info@avtechpulse.com

USAGE PRECAUTIONS

The unit may be damaged if operated into a short circuit. Such failures are not covered by the warranty. The load impedance must be equal to or greater than 50 Ohms.

The input may be damaged if voltages much greater than $\pm 4V$ are applied.

Never apply an external voltage to the output, or the output may be damaged.

INTERNAL ADJUSTMENTS

There is an internal DC offset null trimpot inside the amplifier. If a small DC offset is observed on the output, turn off the instrument. Remove the four screws holding the top cover in place, and slide the cover towards the rear and off. Locate the blue circuit “-PG” module. A small brass screw should be visible on the top surface of the “-PG” module. Turn on the instrument, and rotate this screw until the offset is zero.

The offset was nulled to zero at the time of shipping.

POWER SUPPLY AND FUSE REPLACEMENT

This instrument has three main fuses, plus two spares. One, which protects the AC input, is located in the rear-panel power entry module, as described in the “Rear Panel Controls” section of this manual. If the power appears to have failed, check the AC fuse first.

The other two fuses (plus two spares) are located on the internal DC power supply, as shown below:

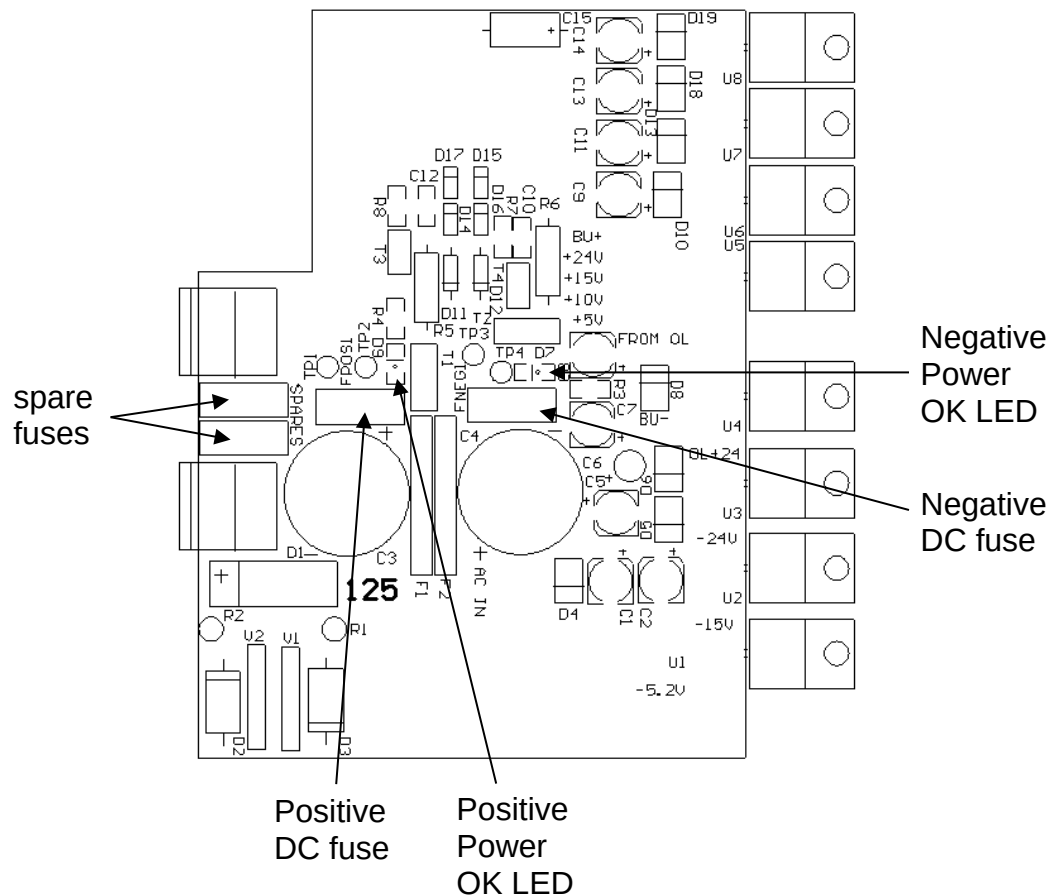

The four fuses on this circuit board are 1.0A slow-blow fuses, Littlefuse part number R452001. (This fuse can be ordered from Digikey, www.digikey.com. The Digikey part number is F1343CT-ND).

If you suspect that the DC fuses are blown, follow this procedure:

1. Remove the top cover, by removing the four Phillips screws on the top cover and then sliding the cover back and off.
2. Locate the two “Power OK” LEDs on the power supply circuit board, as illustrated above.
3. Turn on the instrument.

4. Observe the “Power OK” LEDs. If the fuses are not blown, the two LEDs will be lit (bright red). If one of the LEDs is not lit, the fuse next to it has blown.
5. Turn off the instrument.
6. If a fuse is blown, use needle-nose pliers to remove the blown fuse from its surface-mount holder.
7. Replace the fuse. (Two spare 1.0 Amp fuses are provided on the circuit board. They may be transferred to the active fuse locations using needle-nose pliers.)

PERFORMANCE CHECK SHEET