



AVTECH ELECTROSYSTEMS LTD.

NANOSECOND WAVEFORM ELECTRONICS
SINCE 1975

P.O. BOX 265
OGDENSBURG, NY
U.S.A. 13669-0265
TEL: (315) 472-5270
FAX: (613) 226-2802

TEL: 1-800-265-6681
FAX: 1-800-561-1970

e-mail: info@avtechpulse.com
<http://www.avtechpulse.com/>

BOX 5120, LCD MERIVALE
OTTAWA, ONTARIO
CANADA K2C 3H4
TEL: (613) 226-5772
FAX: (613) 226-2802

INSTRUCTIONS

MODEL AV-145C2-PS-LAA

0 to ± 0.4 V IN,

0 to ± 10 V OUT, TO 50 OHMS,

VARIABLE-GAIN AMPLIFIER

SERIAL NUMBER: _____

WARRANTY

Avtech Electrosystems Ltd. warrants products of its manufacture to be free from defects in material and workmanship under conditions of normal use. If, within one year after delivery to the original owner, and after prepaid return by the original owner, this Avtech product is found to be defective, Avtech shall at its option repair or replace said defective item. This warranty does not apply to units which have been disassembled, modified or subjected to conditions exceeding the applicable specifications or ratings. This warranty is the extent of the obligation assumed by Avtech with respect to this product and no other warranty or guarantee is either expressed or implied.

TECHNICAL SUPPORT

Phone: 613-226-5772 or 1-800-265-6681

Fax: 613-226-2802 or 1-800-561-1970

E-mail: info@avtechpulse.com

World Wide Web: <http://www.avtechpulse.com>

TABLE OF CONTENTS

| | |
|--|-----------|
| WARRANTY..... | 2 |
| TECHNICAL SUPPORT..... | 2 |
| TABLE OF CONTENTS..... | 3 |
| INTRODUCTION..... | 4 |
| SPECIFICATIONS..... | 4 |
| ORIGINAL QUOTATION..... | 5 |
| EC DECLARATION OF CONFORMITY..... | 7 |
| INSTALLATION..... | 8 |
| VISUAL CHECK..... | 8 |
| POWER RATINGS..... | 8 |
| CONNECTION TO THE POWER SUPPLY..... | 8 |
| ENVIRONMENTAL CONDITIONS..... | 8 |
| FUSES..... | 9 |
| AC FUSE REPLACEMENT..... | 9 |
| DC FUSE REPLACEMENT..... | 10 |
| FUSE RATINGS..... | 10 |
| FRONT PANEL CONTROLS..... | 11 |
| REAR PANEL CONTROLS..... | 12 |
| GENERAL INFORMATION..... | 13 |
| BASIC OPERATION..... | 13 |
| OPERATIONAL CHECK..... | 14 |
| USAGE PRECAUTIONS..... | 15 |
| MECHANICAL INFORMATION..... | 16 |
| TOP COVER REMOVAL..... | 16 |
| ELECTROMAGNETIC INTERFERENCE..... | 16 |
| MAINTENANCE..... | 16 |
| REGULAR MAINTENANCE..... | 16 |
| CLEANING..... | 16 |
| PERFORMANCE CHECK SHEET..... | 17 |

INTRODUCTION

The AV-145C2-PS-LAA amplifier has an adjustable gain (V_{OUT}/V_{IN}) of -40 dB to +40 dB. The gain is controlled by a voltage applied to a rear-panel BNC connector, or by a front-panel ten-turn locking dial. A voltage of 0 on the rear-panel connector corresponds to minimum gain, and a voltage of +5V corresponds to maximum gain (40 dB).

The input may range from 0 to $\pm 0.4V$. The input impedance is 50Ω . The maximum output range is 0 to $\pm 10V$, into load impedances of 50Ω or greater.

The output rise and fall times are 5 ns or less.

SPECIFICATIONS

| | |
|--|--|
| Model: | AV-145C2-PS-LAA |
| Bandwidth: | DC-35 MHz |
| Gain: | -40 to +40 dB (C2) (x0.01 to x100 voltage) |
| Peak output: | $\pm 10 V$ |
| Maximum input: | $\pm 400 mV$ |
| Gain control Bandwidth ¹ : | 80 dB/us |
| Control voltage: | 0 to +5 Volts |
| Output noise voltage: | $< 5 mV_{RMS}$ |
| Rise, fall time: | 5 ns |
| Input impedance ² : | Input: 50 Ohms |
| Connectors: | SMA |
| Prime power: | 100 - 240 Volts, 50 - 60 Hz |
| Dimensions:-PS: | 100 mm x 215 mm x 375 mm (3.9" x 8.5" x 14.8") |

- 1) Refers to the rate at which the gain may be varied. This is unrelated to the bandwidth of the output.
- 2) Other input impedances are available. Call Avtech for details.

ORIGINAL QUOTATION

Dec. 17, 2003
 To: William Haynes
 Los Alamos Nat. Lab.
 505-667-1965
 wbhaynes@lanl.gov

William,

Following your recent inquiry, I am pleased to quote as follows:

Quote number: 11875.01

Model number: AV-145C2-PS

Description: Variable Gain Amplifier

Datasheet & pricing: <http://www.avtechpulse.com/variable/av-145c2>

Price: \$2156 US each, FOB destination.

Estimated delivery: 30 days after receipt of order.

Quote number: 11875.02

Model number: AV-145C2-PS-LAA

Description: Variable Gain Amplifier

-LAA option: allows the gain to be controlled by a front-panel ten-dial, or by a 0 to +5V control voltage applied to a rear-panel BNC connector. (The rear-panel BNC connector is the standard gain control method.)

Other: as per the standard AV-145C2-PS

Price: \$2654 US each, FOB destination.

Estimated delivery: 30 days after receipt of order.

Please call or email me if I can be of further assistance.

Regards,
 Dr. Michael J. Chudobiak
 VP, New Product Development

--- Avtech Electrosystems Ltd. ----- since 1975 ---

| | | |
|----------------|---|-----------------|
| PO Box 265 | ph: 1-800-265-6681 or 613-226-5772 | Box 5120, |
| Ogdensburg, | fax: 1-800-561-1970 or 613-226-2802 | LCD Merivale |
| New York | email: info@avtechpulse.com | Ottawa, Ontario |
| USA 13669-0265 | http://www.avtechpulse.com/ | Canada K2C 3H4 |

Nanosecond Waveform Generators
 for general purpose, R&D and OEM applications

Pulse Generators - Laser Diode Drivers - Pulse Amplifiers
 Impulse Generators - Current Pulsers - Delay Generators - Splitters

Function Generators - Monocycle Generators - Frequency Dividers + more!

EC DECLARATION OF CONFORMITY

We

Avtech Electrosystems Ltd.
P.O. Box 5120, LCD Merivale
Ottawa, Ontario
Canada K2C 3H4

declare that this pulse generator meets the intent of Directive 89/336/EEC for Electromagnetic Compatibility. Compliance pertains to the following specifications as listed in the official Journal of the European Communities:

EN 50081-1 Emission

EN 50082-1 Immunity

and that this pulse generator meets the intent of the Low Voltage Directive 72/23/EEC as amended by 93/68/EEC. Compliance pertains to the following specifications as listed in the official Journal of the European Communities:

EN 61010-1:2001 Safety requirements for electrical equipment for measurement, control, and laboratory use



INSTALLATION

VISUAL CHECK

After unpacking the instrument mainframe and the transformer module, examine to ensure that they have not been damaged in shipment. Visually inspect all connectors, knobs, and handles. Confirm that a power cord and an instrumentation manual (this manual), are with the instrument. If the instrument has been damaged, file a claim immediately with the company that transported the instrument.

POWER RATINGS

This instrument is intended to operate from 100 - 240 V, 50 - 60 Hz.

The maximum power consumption is 57 Watts. Please see the "FUSES" section for information about the appropriate AC and DC fuses.

This instrument is an "Installation Category II" instrument, intended for operation from a normal single-phase supply.

CONNECTION TO THE POWER SUPPLY

An IEC-320 three-pronged recessed male socket is provided on the back panel for AC power connection to the instrument. One end of the detachable power cord that is supplied with the instrument plugs into this socket. The other end of the detachable power cord plugs into the local mains supply. Use only the cable supplied with the instrument. The mains supply must be earthed, and the cable used to connect the instrument to the mains supply must provide an earth connection. (The supplied cable does this.)

ENVIRONMENTAL CONDITIONS

This instrument is intended for use under the following conditions:

- a) indoor use;
- b) altitude up to 2 000 m;
- c) temperature 5 °C to 40 °C;
- d) maximum relative humidity 80 % for temperatures up to 31 °C decreasing linearly to 50 % relative humidity at 40 °C;
- e) Mains supply voltage fluctuations up to ± 10 % of the nominal voltage;
- f) no pollution or only dry, non-conductive pollution.

FUSES

This instrument contains four fuses. All are accessible from the rear-panel. Two protect the AC prime power input, and two protect the internal DC power supplies. The locations of the fuses on the rear panel are shown in the figure below:

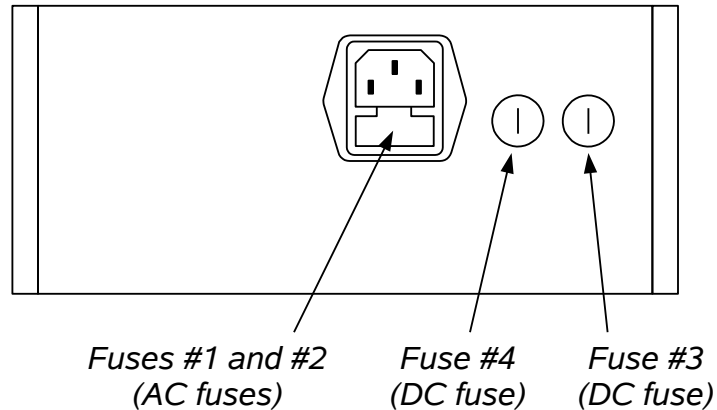

AC FUSE REPLACEMENT

To physically access the AC fuses, the power cord must be detached from the rear panel of the instrument. The fuse drawer may then be extracted using a small flat-head screwdriver, as shown below:

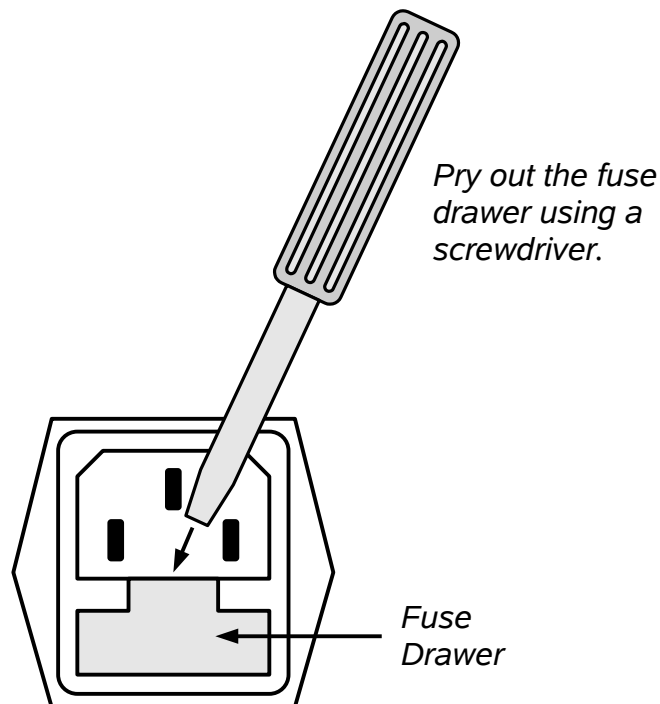

DC FUSE REPLACEMENT

The DC fuses may be replaced by inserting the tip of a flat-head screwdriver into the fuse holder slot, and rotating the slot counter-clockwise. The fuse and its carrier will then pop out.

FUSE RATINGS

The following table lists the required fuses:

| Fuses | Nominal Mains Voltage | Rating | Case Size | Manufacturer's Part Number (Wickmann) | Distributor's Part Number (Digi-Key) |
|-------------|-----------------------|---|-----------|---------------------------------------|--------------------------------------|
| #1, #2 (AC) | 100-240V | 0.5A, 250V, Time-Delay | 5×20 mm | 1950250000 | WK5035-ND |
| #3 (DC) | N/A | 0.8A, 250V, Time-Delay | 5×20 mm | 1950500000 | WK5041-ND |
| #4 (DC) | N/A | Not used. A spare 0.8A fuse is installed here. | | | |

The fuse manufacturer is Wickmann (<http://www.wickmann.com/>).

Replacement fuses may be easily obtained from Digi-Key (<http://www.digikey.com/>) and other distributors.

FRONT PANEL CONTROLS

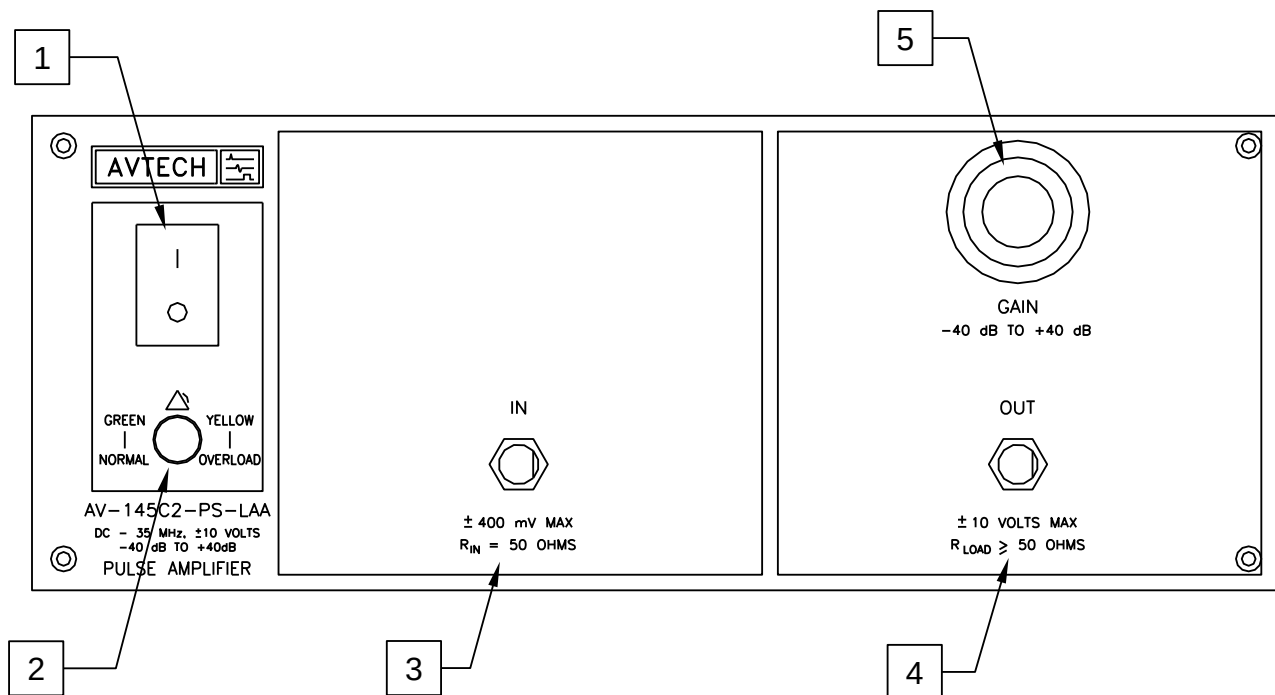

1. POWER Switch. This is the main power switch. When turning the instrument on, there may be a delay of several seconds before the instrument appears to respond.
2. OVERLOAD Indicator. When the instrument is powered, this indicator is normally green, indicating normal operation. If this indicator is yellow, an internal automatic overload protection circuit has been tripped. If the unit is overloaded (by operating at an exceedingly high duty cycle or by operating into a very low impedance), the protective circuit will disable the output of the instrument and turn the indicator light yellow. The light will stay yellow (i.e. output disabled) for about 5 seconds after which the instrument will attempt to re-enable the output (i.e. light green) for about 1 second. If the overload condition persists, the output will be disabled again (i.e. light yellow) for another 5 seconds. If the overload condition has been removed, the instrument will resume normal operation.

This overload indicator may flash yellow briefly at start-up. This is not a cause for concern.

3. IN CONNECTOR. The input signal to be amplified is applied to this SMA connector. The input should not exceed ± 0.4 V. The input impedance is 50Ω .
4. OUT CONNECTOR. This SMA connector provides the main output signal. This output can supply up to ± 10 V into a 50Ω (or greater) load. The output impedance is approximately 2Ω .
5. GAIN CONTROL. When the rear-panel INT/EXT switch is in the INT position, this ten-turn locking dial controls the amplifier gain.

REAR PANEL CONTROLS

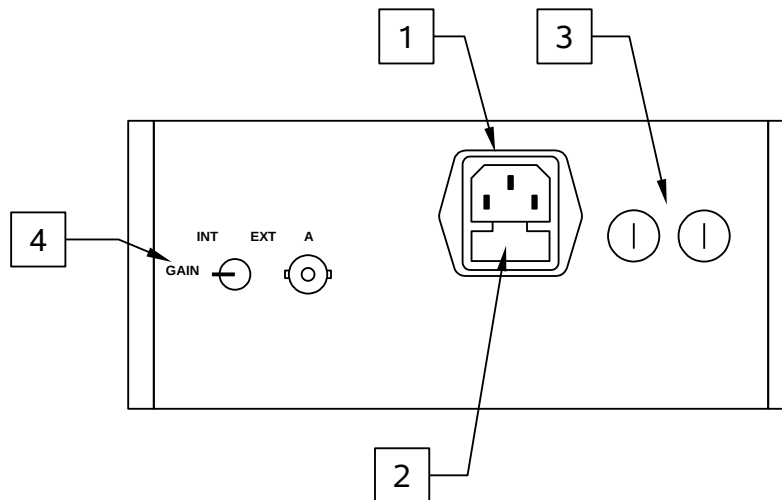

- 1) AC POWER INPUT. An IEC-320 C14 three-pronged recessed male socket is provided on the back panel for AC power connection to the instrument. One end of the detachable power cord that is supplied with the instrument plugs into this socket.
- 2) AC FUSE DRAWER. The two fuses that protect the AC input are located in this drawer. Please see the “FUSES” section of this manual for more information.
- 3) DC FUSES. These two fuses protect the internal DC power supplies. Please see the “FUSES” sections of this manual for more information.
- 4) INT/EXT SWITCH AND INPUT. When this switch is set to the “INT” position, the amplifier gain is controlled by the front-panel amplitude dial. When this switch is set to the “EXT” position, the output amplitude is controlled by the voltage applied to the “A” BNC connector. 0V in corresponds to minimum gain, and +5V DC in corresponds to maximum gain. The input impedance of the “A” connector is > 10 k Ω .

GENERAL INFORMATION

BASIC OPERATION

This instrument is very straightforward to connect and operate. The input signal is connected to the “IN” connector, and the output signal is generated by the amplifier on the “OUT” connector. A gain control voltage in the range of 0 to +5V (typically generated by a DC power supply, or a computer card) is applied to the “GAIN” connector.

The basic test arrangement is shown below:

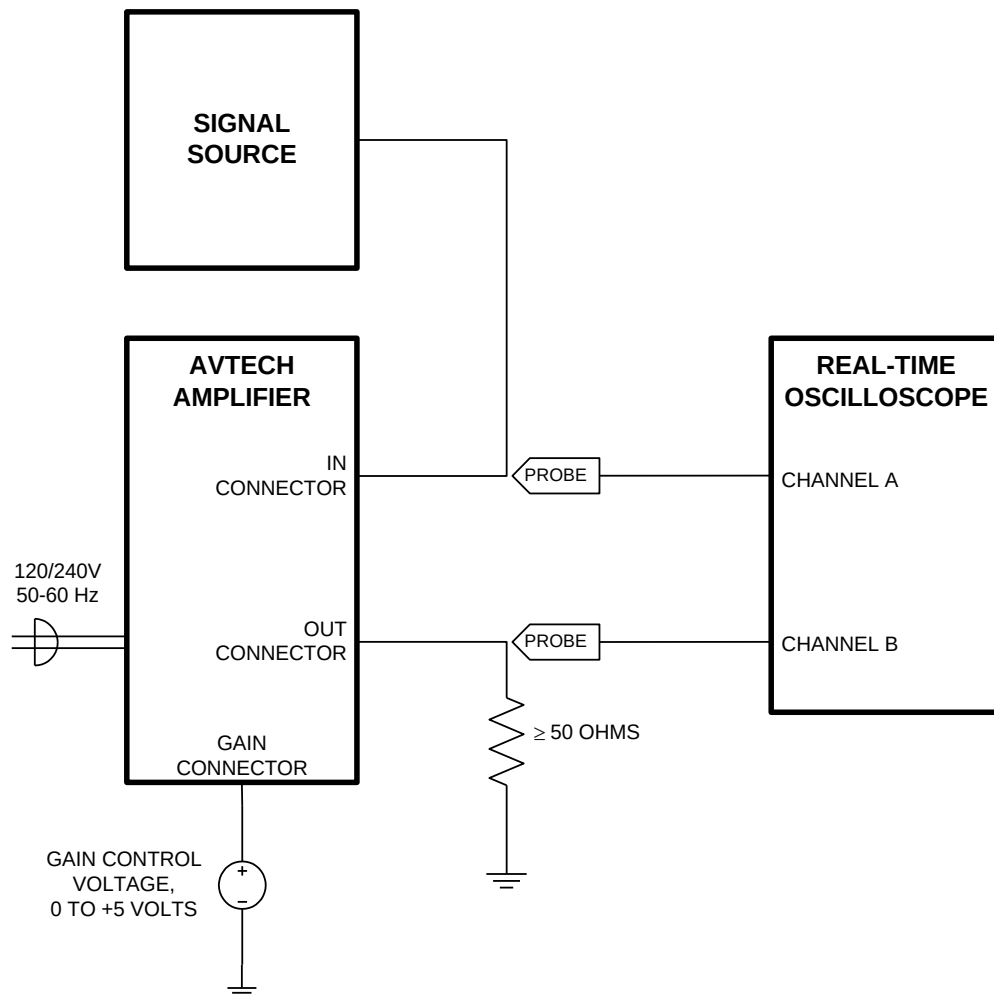

OPERATIONAL CHECK

To confirm the operation of the instrument, connect the amplifier as shown on the previous page. Use a signal source capable of generating a 0 to 50 mV pulse, with rise and fall times of less than 5 ns, and a pulse width of approximately 100 ns. (The Avtech AV-1030-C pulse generator is suitable for this purpose). Attach a DC power supply, capable of generating 0 to +5V, to the GAIN control input.

Confirm that the oscilloscope properly displays the input signal. Then turn on the Avtech amplifier, and observe the output signal on the oscilloscope. Set the gain control voltage to +5V. The output amplitude should be approximately +5V, with rise and fall times of 5 ns (when measured between the 20% and 80% amplitude points of each edge).

Note that if the rise and fall times of the input signal are longer than 5 ns, the output rise and fall times will increase correspondingly.

If additional assistance is required, contact:

Tel: (613) 226-5772, Fax: (613) 226-2802
Email: info@avtechpulse.com

USAGE PRECAUTIONS

The unit may be damaged if operated into a short circuit. Such failures are not covered by the warranty. The load impedance must be equal to or greater than 50 Ohms.

The input may be damaged if input voltages greater than $\pm 0.4V$ are applied.

The gain control voltage must lie between 0 and +5 Volts. The instrument may be damaged by voltages outside of this range.

Never apply an external voltage to the output, or the output may be damaged.

MECHANICAL INFORMATION

TOP COVER REMOVAL

If necessary, the interior of the instrument may be accessed by removing the four Phillips screws on the top panel. With the four screws removed, the top cover may be slid back (and off).

Always disconnect the power cord before opening the instrument.

There are no user-adjustable internal circuits. For repairs other than fuse replacement, please contact Avtech (info@avtechpulse.com) to arrange for the instrument to be returned to the factory for repair.

⚠ Caution: High voltages are present inside the instrument during normal operation. Do not operate the instrument with the cover removed.

ELECTROMAGNETIC INTERFERENCE

To prevent electromagnetic interference with other equipment, all used outputs should be connected to shielded 50Ω loads using shielded 50Ω coaxial cables. Unused outputs should be terminated with shielded 50Ω coaxial terminators or with shielded coaxial dust caps, to prevent unintentional electromagnetic radiation. All cords and cables should be less than 3m in length.

MAINTENANCE

REGULAR MAINTENANCE

This instrument does not require any regular maintenance.

On occasion, one or more of the four rear-panel fuses may require replacement. All fuses can be accessed from the rear panel. See the “FUSES” section for details.

CLEANING

If desired, the interior of the instrument may be cleaned using compressed air to dislodge any accumulated dust. (See the “TOP COVER REMOVAL” section for instructions on accessing the interior.) No other cleaning is recommended.

PERFORMANCE CHECK SHEET