

INSTRUCTIONS

MODEL AV-151E-C

0 to ± 25 V, 20 kHz

HIGH-CURRENT
FUNCTION GENERATOR
and
VARIABLE-GAIN
LINEAR AMPLIFIER

SERIAL NUMBER: _____

WARRANTY

Avtech Electrosystems Ltd. warrants products of its manufacture to be free from defects in material and workmanship under conditions of normal use. If, within one year after delivery to the original owner, and after prepaid return by the original owner, this Avtech product is found to be defective, Avtech shall at its option repair or replace said defective item. This warranty does not apply to units which have been disassembled, modified or subjected to conditions exceeding the applicable specifications or ratings. This warranty is the extent of the obligation assumed by Avtech with respect to this product and no other warranty or guarantee is either expressed or implied.

TECHNICAL SUPPORT

Phone: 613-226-5772 or 1-800-265-6681

Fax: 613-226-2802 or 1-800-561-1970

E-mail: info@avtechpulse.com

World Wide Web: <http://www.avtechpulse.com>

TABLE OF CONTENTS

WARRANTY	2
TECHNICAL SUPPORT	2
TABLE OF CONTENTS	3
INTRODUCTION	4
SPECIFICATIONS	4
INSTALLATION	5
VISUAL CHECK	5
PLUGGING IN THE INSTRUMENT	5
FRONT PANEL CONTROLS	6
REAR PANEL CONTROLS	8
GENERAL INFORMATION	9
BASIC PULSE CONTROL – INTERNAL MODE	9
BASIC PULSE CONTROL – EXTERNAL MODE	9
TOP COVER REMOVAL	10
RACK MOUNTING	10
OPERATIONAL CHECK	11
MAINTENANCE	13
POWER SUPPLY AND FUSE REPLACEMENT	14
PERFORMANCE CHECK SHEET	16

INTRODUCTION

The Model AV-151E-C function generator can produce square, sine, and triangle wave outputs at frequencies up to 20 kHz, with amplitudes of 0 to $\pm 25\text{V}$, and a DC offset of 0 to $\pm 10\text{V}$. The AV-151E-C will drive load impedances of $20\ \Omega$ or higher.

When supplied with an external voltage input, the AV-151E-C may be used as a DC to 20 kHz variable-gain linear amplifier. The gain is variable from 0 to $+12.5\ \text{V/V}$.

SPECIFICATIONS

Model:	AV-151E-C
Output amplitude (max):	$\pm 25\ \text{Volts}$
Load impedance:	$\geq 20\ \Omega$
Internal oscillator frequency range:	2 Hz to 20 kHz
-3dB bandwidth, external mode	20 kHz
Waveforms:	sine, square, triangle
DC offset:	$\pm 10\ \text{Volts}$
Rise time (for max output):	$< 10\ \mu\text{s}$
Ext trig mode:	Input amplitude for maximum output: $\pm 2\ \text{Volts}$
Connectors:	BNC
Power requirement:	120/240 Volts (switchable) 50 - 60 Hz
Dimensions:	100 mm x 215 mm x 375 mm (3.9" x 8.5" x 14.8")

INSTALLATION

VISUAL CHECK

After unpacking the instrument, examine to ensure that it has not been damaged in shipment. Visually inspect all connectors, knobs, and handles. Confirm that a power cord is with the instrument. If the instrument has been damaged, file a claim immediately with the company that transported the instrument.

PLUGGING IN THE INSTRUMENT

Examine the rear of the instrument. There will be a male power receptacle, a fuse holder and the edge of the power selector card visible.

For AC line voltages of 110-120V, the power selector card should be installed so that the "120" marking is visible from the rear of the instrument.

For AC line voltages of 220-240V, the power selector card should be installed so that the "240" marking is visible from the rear of the instrument.

If it is not set for the proper voltage, remove the fuse and then grasp the card with a pair of pliers and remove it. Rotate horizontally through 180 degrees. Reinstall the card and the correct fuse.

In the 120V setting, a 1A slow blow fuse is required. In the 240V setting, a 0.5A slow-blow fuse is required.

FRONT PANEL CONTROLS

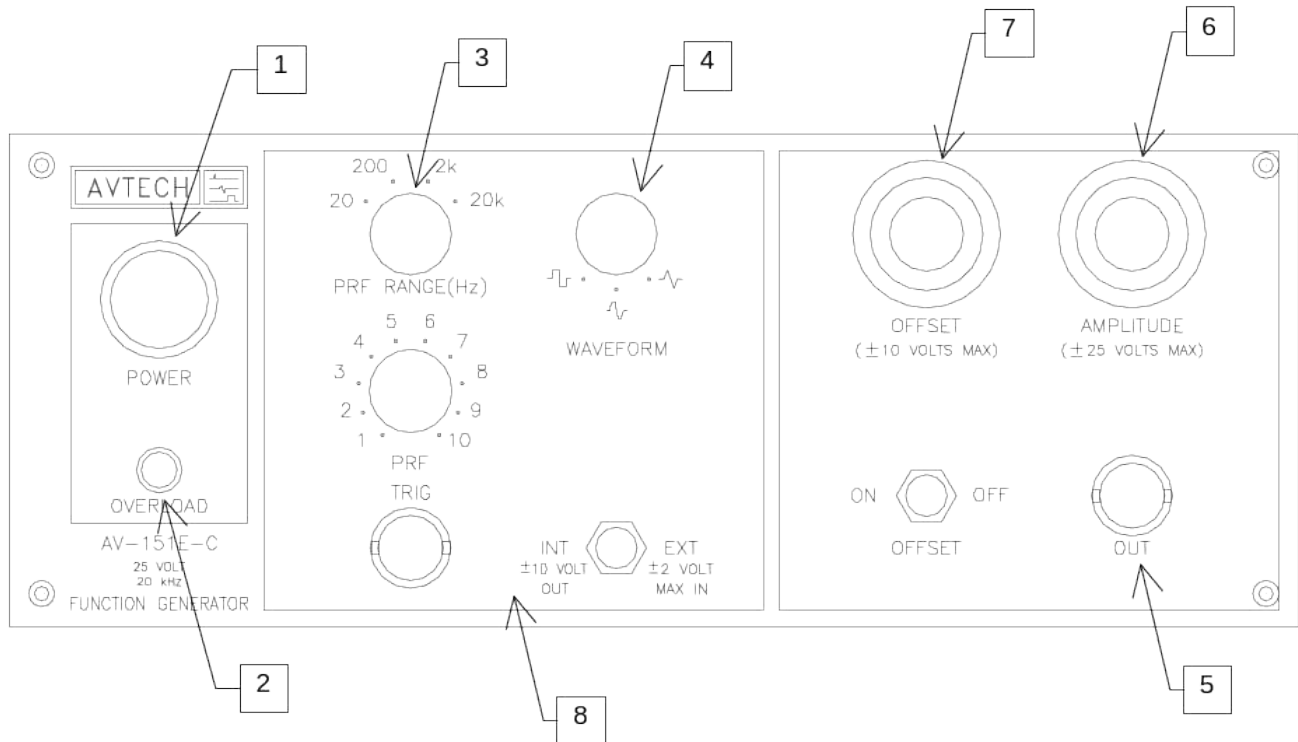

1. **POWER Switch**. The POWER push button switch applies AC prime power to the primaries of the transformer, turning the instrument on. The push button lamp is connected to the +15V DC supply.
2. **OVERLOAD Indicator**. As a protective measure, this instrument includes an automatic overload circuit, which controls the front panel overload light. If the unit is overloaded (for instance, by operating into a very low impedance), the protective circuit will turn the output of the instrument OFF and turn the indicator light ON. The light will stay ON (i.e. output OFF) for about 5 seconds after which the instrument will attempt to turn ON (i.e. light OFF) for about 1 second. If the overload condition persists, the instrument will turn OFF again (i.e. light ON) for another 5 seconds. If the overload condition has been removed, the instrument will turn on and resume normal operation.

This overload indicator is only likely to come on in two situations:

- Briefly at startup. This is not a cause for concern.

- When the load impedance is too low ($< 50 \text{ k}\Omega$). In this case, turn off the instrument and connect the proper load.
3. PRF Controls. Varies output pulse repetition frequency (PRF) as follows:

Range 1	2 to 20 Hz
Range 2	20 to 200 Hz
Range 3	200 to 2000 Hz
Range 4	2 to 20 kHz
 4. WAVEFORM Switch. This 3-position switch selects between square, sine or triangular output at the main output.
 5. OUT Connector. This BNC connector provides the main output signal.
 6. AMPLITUDE Control. This ten-turn control determines amplitude of the signal at the main output.
 7. OFFSET Control. This ten-turn control allows a DC offset to be added to the signal on the main output. ON-OFF switch turns the DC offset feature on or off.
 8. INT-EXT, TRIG. With this two-position is switch in the INT position, the frequency and shape of the 2 Hz to 20 kHz component on the main output are determined by the front-panel controls.

Also, in this position a ± 10 Volt square wave (with an output impedance of $1 \text{ k}\Omega$) is provided at the TRIG BNC connector for the purpose of triggering a scope. This output can drive 50 Ohm loads, but the voltage will be reduced to $\pm 0.5\text{V}$.

When the two-position switch is in the EXT position, the AV-151E-C may be used as a DC-20 kHz variable-gain voltage-to-current converter/amplifier. The gain is variable from +0 to +12.5 V/V, approximately. The required input signal is applied to the TRIG connector for this mode of operation.

REAR PANEL CONTROLS

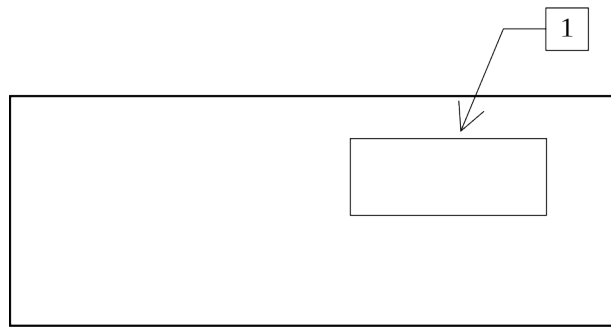

1. AC POWER INPUT. A three-pronged recessed male connector is provided on the back panel for AC power connection to the instrument. Also contained in this assembly is a slow-blow fuse and a removable power selector card that can be removed and repositioned to switch between 110-120V AC in and 220-240V.

For AC line voltages of 110-120V, the power selector card should be installed so that the "120" marking is visible from the rear of the instrument.

For AC line voltages of 220-240V, the power selector card should be installed so that the "240" marking is visible from the rear of the instrument.

If it is not set for the proper voltage, remove the fuse and then grasp the card with a pair of pliers and remove it. Rotate horizontally through 180 degrees. Reinstall the card and the correct fuse.

In the 120V setting, a 1A slow blow fuse is required. In the 240V setting, a 0.5A slow-blow fuse is required.

GENERAL INFORMATION

BASIC PULSE CONTROL – INTERNAL MODE

Operation in the internal mode is straightforward. The output may be set to be a triangle, sine, or square wave, as illustrated below:

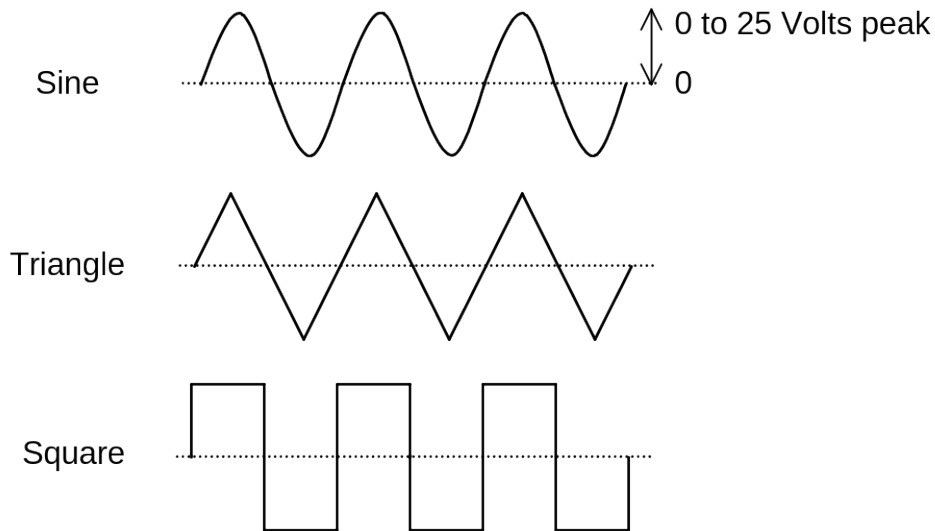

A DC offset may also be added:

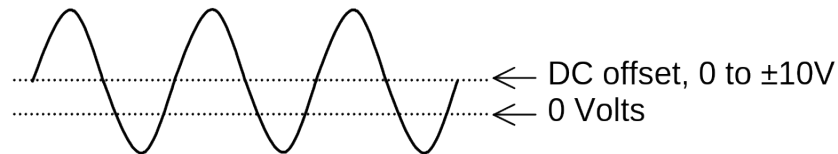

The total output (i.e., the sum of the offset and the amplitude) may not exceed $\pm 25V$.

BASIC PULSE CONTROL – EXTERNAL MODE

When the "INT/EXT" switch is in the "EXT" position, the AV-151E-C may be used as a DC-20 kHz variable-gain linear amplifier. The gain is variable from 0 to +12.5 V/V, and is adjusted by rotating the amplitude control.

The required voltage input signal is applied at TRIG for this mode of operation.

This mode is illustrated below:

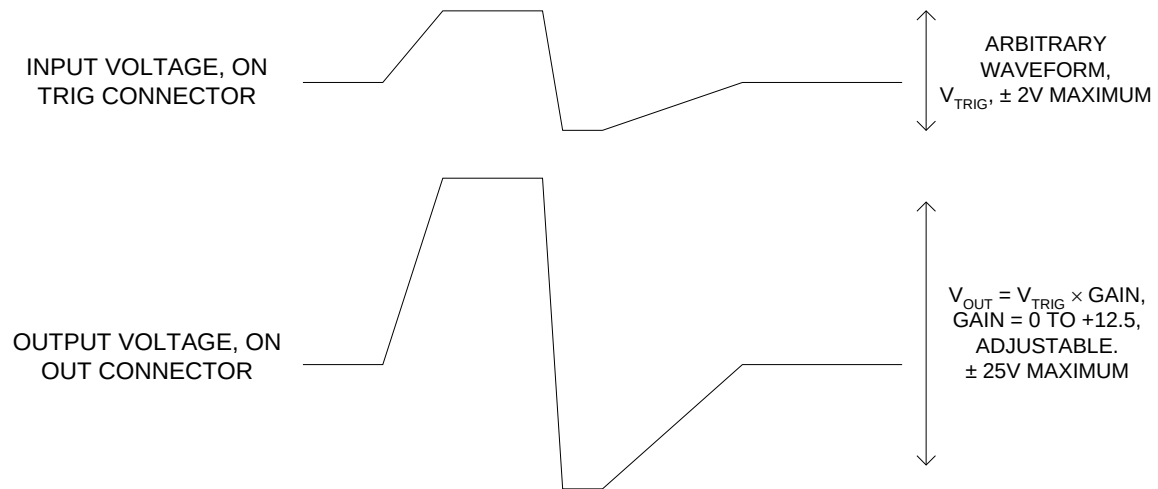

TOP COVER REMOVAL

The top cover of the instrument may be removed by removing the four Phillips screws on the top panel. With these four screws removed, the top panel may be slid off by pulling it towards the rear.

The instrument should not be accessed internally unless it has been turned off for ten minutes, to allow all internal capacitors to discharge. The internal capacitor bank stores a considerable amount of energy.

RACK MOUNTING

A rack mounting kit is available. The -R5 rack mount kit may be installed after first removing the one Phillips screw on the side panel adjacent to the front handle.

OPERATIONAL CHECK

This section describes a sequence to confirm the basic operation of the instrument. It should be performed after receiving the instrument. It is a useful learning exercise as well.

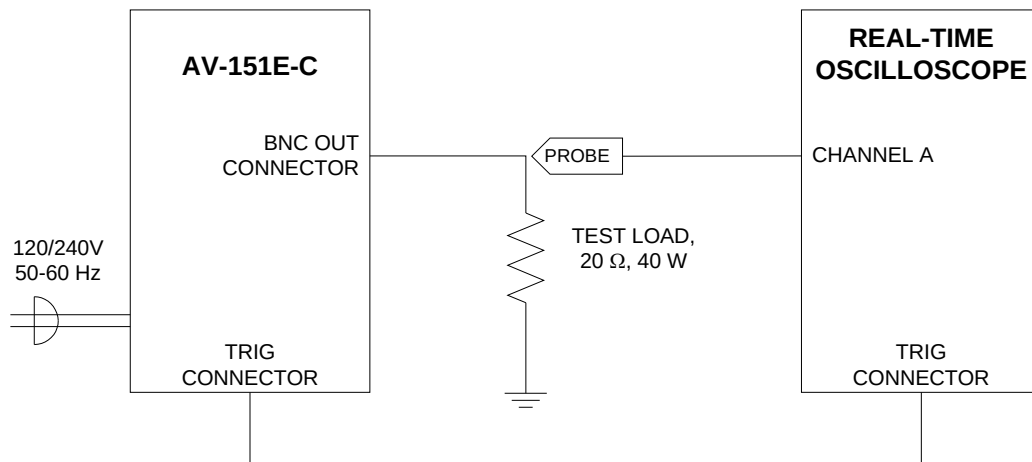

Basic Test Arrangement

- 1) Connect a 20 Ω , 40 Watt test load between the OUT connector and ground.
- 2) Connect a cable from the TRIG connector to the TRIG input of an oscilloscope. Set the oscilloscope to trigger externally.
- 3) Connect one oscilloscope probe (channel A) to the OUT load. On the oscilloscope, set the channel A vertical scale to 10 V/div, and the horizontal scale to 20 μ s/div.
- 4) Set the PRF range switch to the 2 kHz range, and rotate the PRF fine control fully clockwise.
- 5) Set the INT/EXT switch to "INT".
- 6) Set the waveform switch to the sine wave position.
- 7) Set the Offset ON/OFF switch to "OFF".
- 8) Turn on the AV-151E-C. There may be a short delay as the overload circuit resets.
- 9) Rotate the amplitude ten-turn dial to its maximum setting.
- 10) Observe the oscilloscope. You should see a 2 kHz, ± 25 V sine wave.

- 11) Observe the waveform as you switch between the sine, triangle, and square wave modes using the waveform switch.
- 12) Reduce the amplitude to $\pm 10V$, using the amplitude ten-turn dial.
- 13) Switch the Offset ON/OFF switch to "ON", and rotate the offset ten-turn dial. The output waveform should shift vertically on the oscilloscope.
- 14) This completes the operational check.

If additional assistance is required:

Tel: (613) 226-5772
Fax: (613) 226-2802
Email: info@avtechpulse.com

MAINTENANCE

The fan grille, located on the bottom of the instrument, should be cleaned once a year so that it does not become blocked. To clean the grille, use a high-power vacuum cleaner.

POWER SUPPLY AND FUSE REPLACEMENT

This instrument has three main fuses, plus two spares. One, which protects the AC input, is located in the rear-panel power entry module, as described in the “Rear Panel Controls” section of this manual. If the power appears to have failed, check the AC fuse first.

The other two fuses (plus two spares) are located on the internal DC power supply, as shown below:

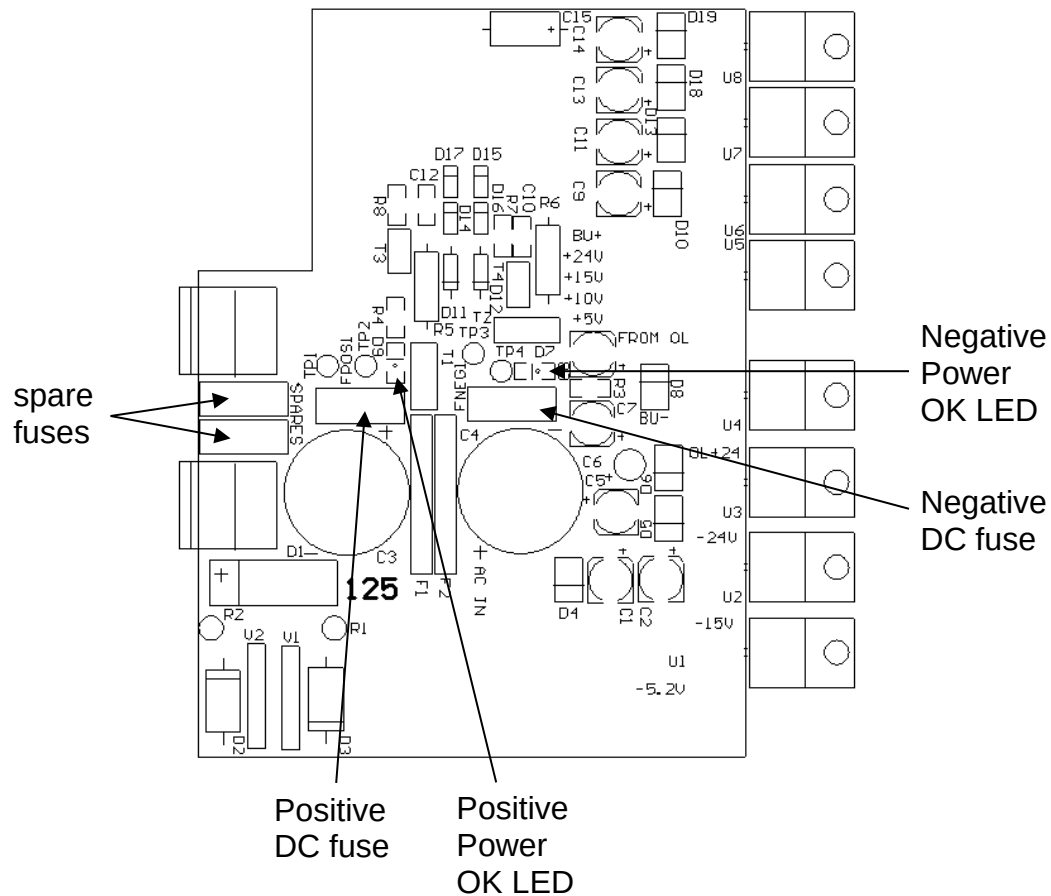

The four fuses on this circuit board are 1.5A slow-blow fuses, Littlefuse part number R45201.5. (This fuse can be ordered from Digikey, www.digikey.com. The Digikey part number is F1344CT-ND).

If you suspect that the DC fuses are blown, follow this procedure:

1. Remove the top cover, by removing the four Phillips screws on the top cover and then sliding the cover back and off.
2. Locate the two “Power OK” LEDs on the power supply circuit board, as illustrated above.

3. Turn on the instrument.
4. Observe the "Power OK" LEDs. If the fuses are not blown, the two LEDs will be lit (bright red). If one of the LEDs is not lit, the fuse next to it has blown.
5. Turn off the instrument.
6. If a fuse is blown, use needle-nose pliers to remove the blown fuse from its surface-mount holder.
7. Replace the fuse. (Two spare 1.5 Amp fuses are provided on the circuit board. They may be transferred to the active fuse locations using needle-nose pliers.)

PERFORMANCE CHECK SHEET