



AVTECH ELECTROSYSTEMS LTD.

NANOSECOND WAVEFORM ELECTRONICS
SINCE 1975

P.O. BOX 265
OGDENSBURG, NY
U.S.A. 13669-0265
TEL: (315) 472-5270
FAX: (613) 226-2802

TEL: 1-800-265-6681
FAX: 1-800-561-1970

e-mail: info@avtechpulse.com
<http://www.avtechpulse.com/>

BOX 5120, LCD MERIVALE
OTTAWA, ONTARIO
CANADA K2C 3H4
TEL: (613) 226-5772
FAX: (613) 226-2802

INSTRUCTIONS

MODEL AV-153A-B

0 to ± 200 V AMPLITUDE
HIGH-VOLTAGE FUNCTION GENERATOR
AND VARIABLE-GAIN LINEAR AMPLIFIER
WITH IEEE 488.2 AND RS-232 CONTROL

SERIAL NUMBER: _____

WARRANTY

Avtech Electrosystems Ltd. warrants products of its manufacture to be free from defects in material and workmanship under conditions of normal use. If, within one year after delivery to the original owner, and after prepaid return by the original owner, this Avtech product is found to be defective, Avtech shall at its option repair or replace said defective item. This warranty does not apply to units which have been disassembled, modified or subjected to conditions exceeding the applicable specifications or ratings. This warranty is the extent of the obligation assumed by Avtech with respect to this product and no other warranty or guarantee is either expressed or implied.

TECHNICAL SUPPORT

Phone: 613-226-5772 or 1-800-265-6681

Fax: 613-226-2802 or 1-800-561-1970

E-mail: info@avtechpulse.com

World Wide Web: <http://www.avtechpulse.com>

TABLE OF CONTENTS

WARRANTY	2
TECHNICAL SUPPORT	2
TABLE OF CONTENTS	3
INTRODUCTION	5
HIGH-VOLTAGE PRECAUTIONS	6
SPECIFICATIONS	7
EC DECLARATION OF CONFORMITY	8
INSTALLATION	9
VISUAL CHECK	9
POWER RATINGS	9
CONNECTION TO THE POWER SUPPLY	9
ENVIRONMENTAL CONDITIONS	9
FUSES	10
AC FUSE REPLACEMENT	10
DC FUSE REPLACEMENT	11
FUSE RATINGS	11
FRONT PANEL CONTROLS	12
REAR PANEL CONTROLS	14
GENERAL INFORMATION	15
WAVESHAPES SELECTION	15
SINE, TRIANGLE, AND SQUARE WAVE GENERATION	15
PULSE GENERATION	16
AMPLIFY MODE	16
RESISTIVE AND CAPACITIVE LOADS	17
DC OFFSET	17
MECHANICAL INFORMATION	18
TOP COVER REMOVAL	18
RACK MOUNTING	18
ELECTROMAGNETIC INTERFERENCE	18
MAINTENANCE	19
REGULAR MAINTENANCE	19
CLEANING	19

- OPERATIONAL CHECK.....20**
- PROGRAMMING YOUR PULSE GENERATOR.....23**
 - KEY PROGRAMMING COMMANDS.....23
 - ALL PROGRAMMING COMMANDS.....24
- OTHER INFORMATION.....26**
 - APPLICATION NOTES.....26
 - MANUAL FEEDBACK.....26
- WIRING DIAGRAMS..... 0**
 - WIRING OF AC POWER..... 0
 - PCB 158D - LOW VOLTAGE POWER SUPPLY, 1/3..... 1
 - PCB 158D - LOW VOLTAGE POWER SUPPLY, 2/3..... 2
 - PCB 158D - LOW VOLTAGE POWER SUPPLY, 3/3..... 3
 - HIGH-VOLTAGE DC POWER SUPPLIES..... 4
 - WIRING OF TIMING BOARDS..... 5
- PERFORMANCE CHECK SHEET..... 0**

Manual Reference: /fileserver1/officefiles/instructword/av-151-153/AV-153A-B,edition2.sxw.
Last modified February 29, 2024.
Copyright © 2024 Avtech Electrosystems Ltd, All Rights Reserved.

INTRODUCTION

The AV-153A-B is a high-performance GPIB and RS232-equipped function generator that can produce square, sine, triangle, and pulse outputs at frequencies up to 300 kHz, with peak amplitudes of 0 to 200V. For the sine, triangle, and square wave modes, this produces peak-to-peak amplitudes of up to 400V.

The AV-153A-B will drive load impedances of 5 k Ω or higher. The AV-153A-B can also drive capacitive loads, at reduced frequencies.

When supplied with an external voltage input, the AV-153A-B may be used as a DC to 300 kHz variable-gain linear amplifier. The gain is variable from +1 to +100.

The AV-153A-B features front panel keyboard and adjust knob control of the output pulse parameters along with a four line by 40 character back-lit LCD display of the output amplitude, waveshape, and frequency. The instrument includes memory to store up to four complete instrument setups. The operator may use the front panel or the computer interface to store a complete "snapshot" of all key instrument settings, and recall this setup at a later time.

This instrument is intended for use in research and development laboratories.

HIGH-VOLTAGE PRECAUTIONS

 **CAUTION:** This instrument provides output voltages as high as ± 200 Volts, so extreme caution must be employed when using this instrument. The instrument should only be used by individuals who are thoroughly skilled in high voltage laboratory techniques. The following precaution should always be observed:

1. Keep exposed high-voltage wiring to an absolute minimum.
2. Wherever possible, use shielded connectors and cabling.
3. Connect and disconnect loads and cables only when the amplifier is turned off.
4. Keep in mind that all cables, connectors, oscilloscope probes, and loads must have an appropriate voltage rating.
5. Do not attempt any repairs on the instrument, beyond the fuse replacement procedures described in this manual. Contact Avtech technical support (see page 2 for contact information) if the instrument requires servicing.

SPECIFICATIONS

Model:	AV-153A-B
Output amplitude	0 to ± 200 Volts
GPIB and RS-232 control:	included
Load resistance:	≥ 5 k Ω
Avg. output power:	15 Watts maximum
Minimum frequency:	30 Hz
Maximum frequency: (for a given load resistance and capacitance) ¹ :	300 kHz (5 k Ω 0 nF) 60 kHz (5 k Ω 1 nF) 20 kHz (5 k Ω 3 nF) 10 kHz (5 k Ω 10 nF)
Square wave rise time: (for a given load resistance and capacitance) ¹ :	1 μ s (5 k Ω 0 nF) 1.2 μ s (5 k Ω 1 nF) 2.7 μ s (5 k Ω 3 nF) 9.5 μ s (5 k Ω 10 nF)
Waveforms:	Sine, square, triangle, or pulse
Pulse width (pulse mode):	1 μ s to 500 ms
Duty cycle:	Sine, Square and Triangle modes: fixed, 50%. Pulse mode: variable, 80% maximum Amplify mode: variable, 100% maximum
Ext trig mode:	Input Amp for max output: ± 2 Volts (1 k Ω input impedance)
Connectors:	BNC
Power requirement:	100 - 240 Volts, 50 - 60 Hz
Dimensions:	100 mm x 430 mm x 375 mm, 3.9" x 17" x 14.8" (H x W x D)

1) The || symbol means "in parallel with".

EC DECLARATION OF CONFORMITY

We

Avtech Electrosystems Ltd.
P.O. Box 5120, LCD Merivale
Ottawa, Ontario
Canada K2C 3H4

declare that this pulse generator meets the intent of Directive 89/336/EEC for Electromagnetic Compatibility. Compliance pertains to the following specifications as listed in the official Journal of the European Communities:

EN 50081-1 Emission

EN 50082-1 Immunity

and that this pulse generator meets the intent of the Low Voltage Directive 72/23/EEC as amended by 93/68/EEC. Compliance pertains to the following specifications as listed in the official Journal of the European Communities:

EN 61010-1:2001 Safety requirements for electrical equipment for measurement, control, and laboratory use



INSTALLATION

VISUAL CHECK

After unpacking the instrument, examine to ensure that it has not been damaged in shipment. Visually inspect all connectors, knobs, liquid crystal displays (LCDs), and the handles. Confirm that a power cord, a GPIB cable, and two instrumentation manuals (this manual and the “Programming Manual for -B Instruments”) are with the instrument. If the instrument has been damaged, file a claim immediately with the company that transported the instrument.

POWER RATINGS

This instrument is intended to operate from 100 - 240 V, 50 - 60 Hz.

The maximum power consumption is 90 Watts. Please see the “FUSES” section for information about the appropriate AC and DC fuses.

This instrument is an “Installation Category II” instrument, intended for operation from a normal single-phase supply.

CONNECTION TO THE POWER SUPPLY

An IEC-320 three-pronged recessed male socket is provided on the back panel for AC power connection to the instrument. One end of the detachable power cord that is supplied with the instrument plugs into this socket. The other end of the detachable power cord plugs into the local mains supply. Use only the cable supplied with the instrument. The mains supply must be earthed, and the cable used to connect the instrument to the mains supply must provide an earth connection. (The supplied cable does this.)

ENVIRONMENTAL CONDITIONS

This instrument is intended for use under the following conditions:

1. indoor use;
2. altitude up to 2 000 m;
3. temperature 5 °C to 40 °C;
4. maximum relative humidity 80 % for temperatures up to 31 °C decreasing linearly to 50 % relative humidity at 40 °C;
5. Mains supply voltage fluctuations up to ± 10 % of the nominal voltage;
6. no pollution or only dry, non-conductive pollution.

FUSES

This instrument contains four fuses. All are accessible from the rear-panel. Two protect the AC prime power input, and two protect the internal DC power supplies. The locations of the fuses on the rear panel are shown in the figure below:

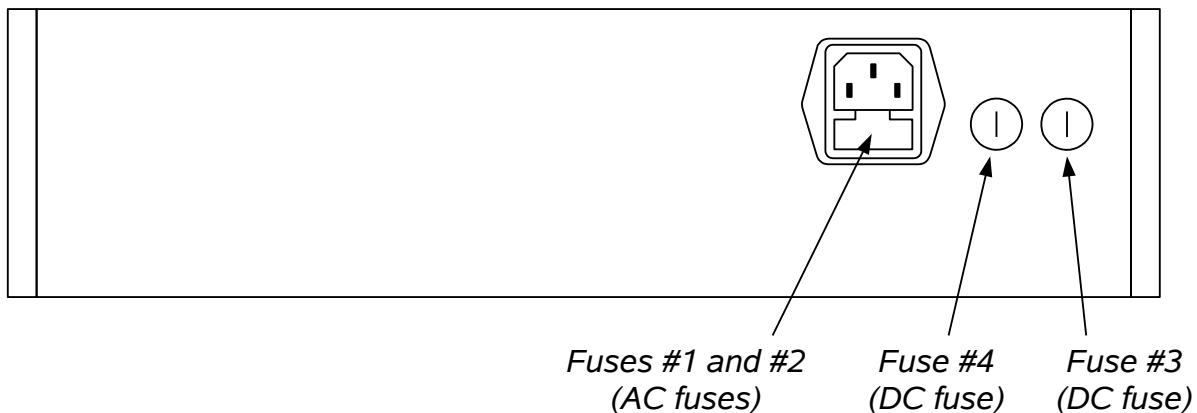

AC FUSE REPLACEMENT

To physically access the AC fuses, the power cord must be detached from the rear panel of the instrument. The fuse drawer may then be extracted using a small flat-head screwdriver, as shown below:

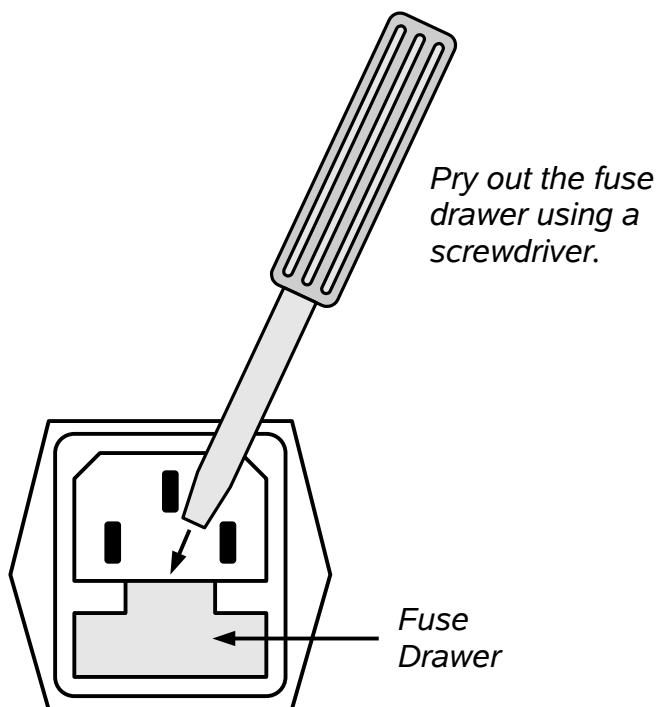

DC FUSE REPLACEMENT

The DC fuses may be replaced by inserting the tip of a flat-head screwdriver into the fuse holder slot, and rotating the slot counter-clockwise. The fuse and its carrier will then pop out.

FUSE RATINGS

The following table lists the required fuses:

Fuses	Nominal Mains Voltage	Rating	Case Size	Manufacturer's Part Number (Wickmann)	Distributor's Part Number (Digi-Key)
#1, #2 (AC)	115 V	0.8A, 250V, Time-Delay	5×20 mm	1950800000	WK5046-ND
	230 V	0.5A, 250V, Time-Delay	5×20 mm	1950500000	WK5041-ND
#3 (DC)	N/A	3.15A, 250V, Time-Delay	5×20 mm	1951315000	WK5124-ND
#4 (DC)	N/A	2.5A, 250V, Time-Delay	5×20 mm	1951250000	WK5058-ND

The fuse manufacturer is Wickmann (<http://www.wickmann.com/>).

Replacement fuses may be easily obtained from Digi-Key (<http://www.digikey.com/>) and other distributors.

FRONT PANEL CONTROLS

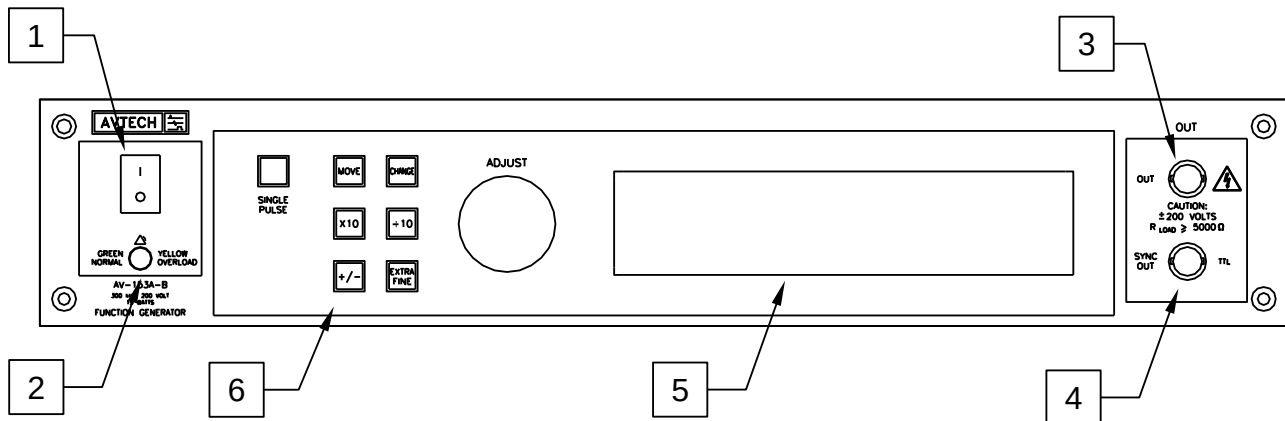

1. POWER Switch. This is the main power switch. When turning the instrument on, there may be a delay of several seconds before the instrument appears to respond.
2. OVERLOAD Indicator. When the instrument is powered, this indicator is normally green, indicating normal operation. If this indicator is yellow, an internal automatic overload protection circuit has been tripped. If the unit is overloaded (by operating at an exceedingly high duty cycle or by operating into a very low impedance), the protective circuit will disable the output of the instrument and turn the indicator light yellow. The light will stay yellow (i.e. output disabled) for about 5 seconds after which the instrument will attempt to re-enable the output (i.e. light green) for about 1 second. If the overload condition persists, the output will be disabled again (i.e. light yellow) for another 5 seconds. If the overload condition has been removed, the instrument will resume normal operation.

This overload indicator may flash yellow briefly at start-up. This is not a cause for concern.

Note that the output stage will safely withstand a short-circuited load condition.

3. OUT Connector. This BNC connector provides the main output signal, into load impedances of $> 5 \text{ k}\Omega$.

 **Caution:** Voltages as high as $\pm 200\text{V}$ may be present on the center conductor of this output connector. Avoid touching this conductor. Connect to this connector using standard coaxial cable, to ensure that the center conductor is not exposed.

4. SYNC OUT. This connector supplies a SYNC output that can be used to trigger other equipment, particularly oscilloscopes. This signal has an approximate amplitude of $+3 \text{ Volts}$ to $R_L > 1 \text{ k}\Omega$ with a pulse width of approximately 200 ns .
5. LIQUID CRYSTAL DISPLAY (LCD). This LCD is used in conjunction with the keypad to change the instrument settings. Normally, the main menu is displayed, which lists the key adjustable parameters and their current values. The

“Programming Manual for -B Instruments” describes the menus and submenus in detail.

6. KEYPAD.

Control Name	Function
MOVE	This moves the arrow pointer on the display.
CHANGE	This is used to enter the submenu, or to select the operating mode, pointed to by the arrow pointer.
× 10	If one of the adjustable numeric parameters is displayed, this increases the setting by a factor of ten.
÷ 10	If one of the adjustable numeric parameters is displayed, this decreases the setting by a factor of ten.
+/-	If one of the adjustable numeric parameters is displayed, and this parameter can be both positive or negative, this changes the sign of the parameter.
EXTRA FINE	This changes the step size of the ADJUST knob. In the extra-fine mode, the step size is twenty times finer than in the normal mode. This button switches between the two step sizes.
ADJUST	This large knob adjusts the value of any displayed numeric adjustable values, such as frequency, pulse width, etc. The adjust step size is set by the "EXTRA FINE" button. When the main menu is displayed, this knob can be used to move the arrow pointer.

REAR PANEL CONTROLS

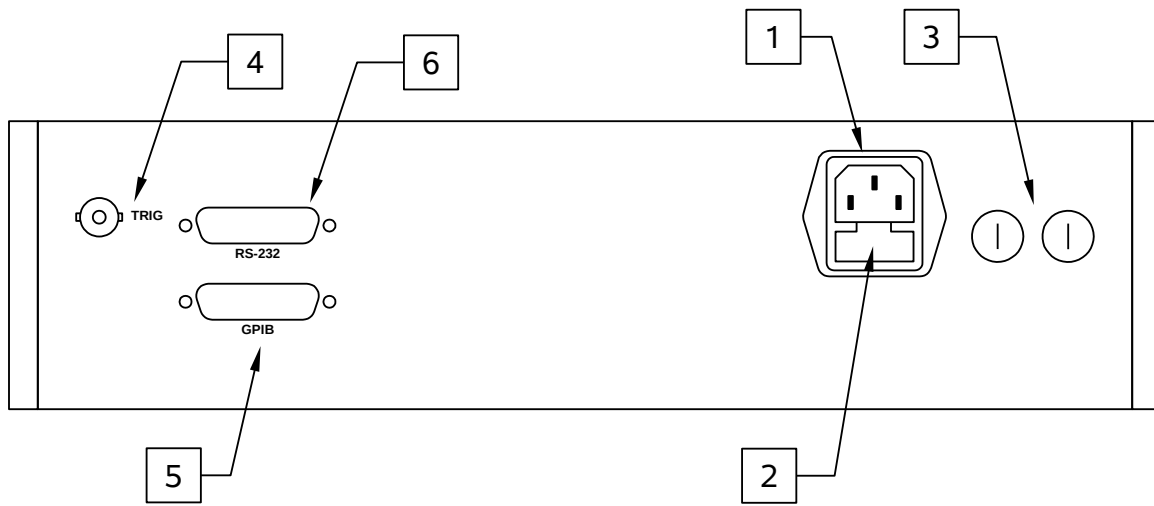

1. AC POWER INPUT. An IEC-320 C14 three-pronged recessed male socket is provided on the back panel for AC power connection to the instrument. One end of the detachable power cord that is supplied with the instrument plugs into this socket.
2. AC FUSE DRAWER. The two fuses that protect the AC input are located in this drawer. Please see the “FUSES” section of this manual for more information.
3. DC FUSES. These two fuses protect the internal DC power supplies. Please see the “FUSES” sections of this manual for more information.
4. TRIG. When the AV-153A-B is set to operate in the amplifier mode, the externally-generated input signal is applied to this connector. The maximum input voltage is $\pm 2V$. The input impedance of this input is 1 k Ω . (Depending on the length of cable attached to this input, and the source driving it, it may be desirable to add a coaxial 50 Ohm terminator to this input to provide a proper transmission line termination. The Pasternack (www.pasternack.com) PE6008-50 BNC feed-thru 50 Ohm terminator is suggested for this purpose.)
5. GPIB Connector. A standard GPIB cable can be attached to this connector to allow the instrument to be computer-controlled. See the “OP1B Interface Programming Manual” for more details on GPIB control.
6. RS-232 Connector. A standard serial cable with a 25-pin male connector can be attached to this connector to allow the instrument to be computer-controlled. See the “OP1B Interface Programming Manual” for more details on RS-232 control.

GENERAL INFORMATION

WAVESHAPE SELECTION

The front-panel “SHAPE” menu or the “sour:func” computer command can be used to set the output waveform to one of five possible modes:

SINE – This mode generates a bipolar sinusoidal signal with 50% duty cycle.

TRIANGLE – This mode generates a bipolar triangle-wave signal with 50% duty cycle.

SQUARE – This mode generates a bipolar square-wave signal with 50% duty cycle.

PULSE – This mode generates a unipolar pulse signal, with adjustable pulse width.

AMPLIFY – This mode causes the instrument to amplify an externally-generated signal.

SINE, TRIANGLE, AND SQUARE WAVE GENERATION

When set to the SINE, TRIANGLE, or SQUARE modes, the output frequency and peak amplitude are controlled from the front panel (or by computer command). The output signal in these modes is bipolar (i.e., the signal swings from a positive value to an approximately equal negative amplitude), and the duty cycle is nominally 50% (i.e., time that the signal is positive is equal in length to the time that the signal is negative.)

These waveforms are illustrated below:

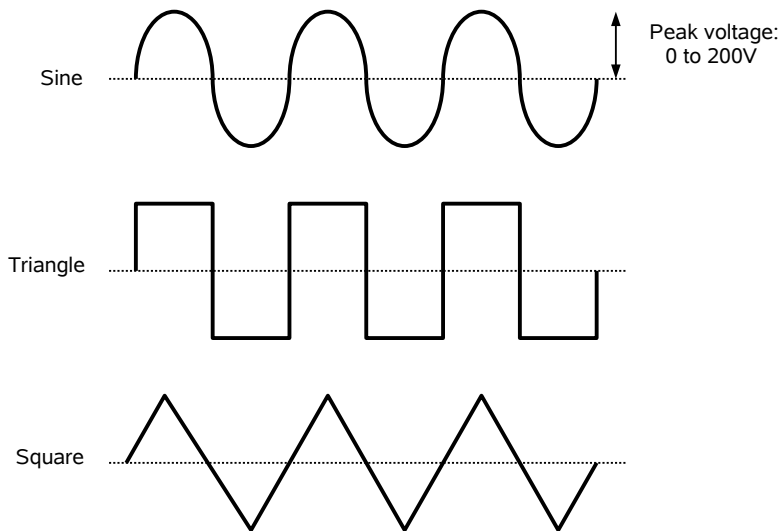

A SYNC output is provided on the front-panel. This provides a 200 ns, 3V signal for triggering oscilloscopes or other equipment. In these modes, the delay (or relative phase) between the main output and the SYNC output is not adjustable.

PULSE GENERATION

The AV-153A-B can also act as a pulse generator, with variable delay between the SYNC output and the main output. In this mode, the pulse width may be varied over a wide range (1 μ s to 500 ms), and the amplitude may be varied from 0 to +200V. (Negative pulses can not be generated directly. However, they can be generated indirectly by adding a negative DC offset. See the offset discussion below.) The maximum duty cycle ($100\% \times \text{Pulse Width} / \text{Period}$) is 80%.

The outputs in this mode are shown below, assuming that the delay is set to a positive value:

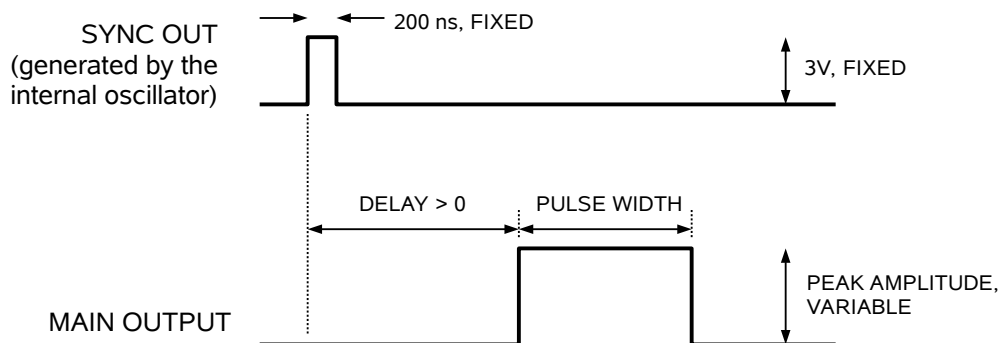

If the delay is negative, the order of the SYNC and OUT pulses is reversed:

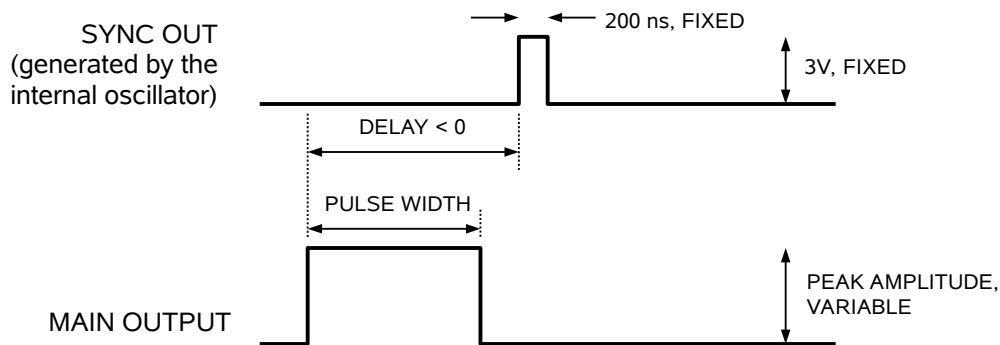

AMPLIFY MODE

When the AMPLIFY mode is enabled, AV-153A-B may be used as a DC-300 kHz variable-gain linear amplifier. The maximum gain is +100. The maximum input signal is ± 2 V. The gain is adjusted by varying the amplitude setting, which corresponds to the output that would be obtained for a +2V input. (For instance, to obtain a gain of +75, set the amplitude to +150V. If a -0.8V signal is applied, for instance, the actual output would be -60V, not +150V.)

The required voltage input signal is applied at TRIG for this mode of operation.

This mode is illustrated below:

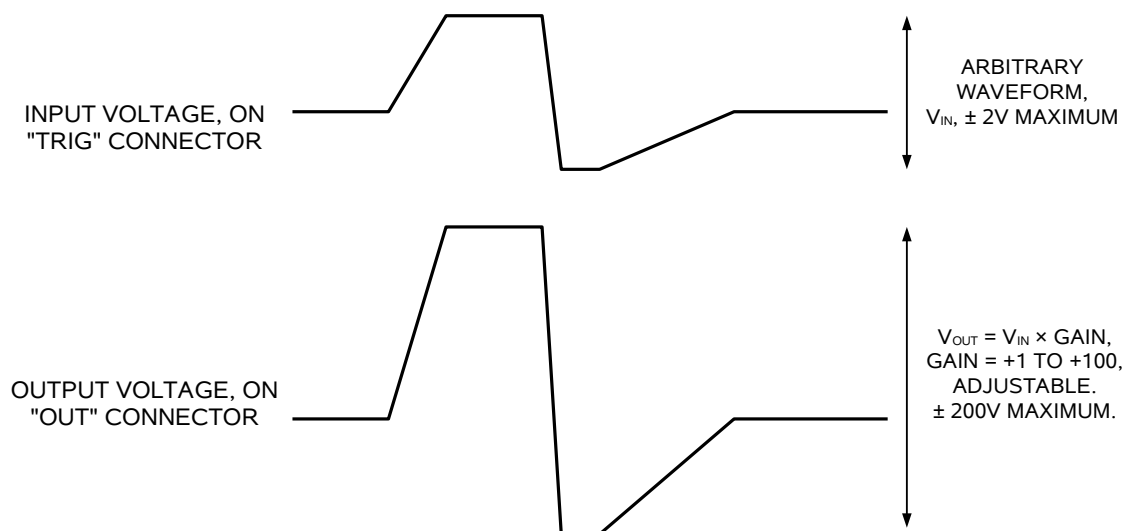

RESISTIVE AND CAPACITIVE LOADS

The AV-153A-B can drive resistive loads with impedances of 5 k Ω and higher. At reduced frequencies, the AV-153A-B can also drive a capacitive load of up to 10000 pF. The reduced maximum frequencies and increased rise times are outlined in the following table:

Maximum frequency: (for a given load resistance and capacitance) :	300 kHz (5 k Ω 0 nF) 60 kHz (5 k Ω 1 nF) 20 kHz (5 k Ω 3 nF) 10 kHz (5 k Ω 10 nF)
Squ. wave rise time: (for a given load resistance and capacitance) :	1 us (5 k Ω 0 nF) 1.2 us (5 k Ω 1 nF) 2.7 us (5 k Ω 3 nF) 9.5 us (5 k Ω 10 nF)

Please note that the capacitance figure includes the parasitic capacitance of any cabling, as well as the capacitance of the device under test. Common coaxial cable typically adds 15 pF per foot of cable.

DC OFFSET

In all modes, a DC offset may be added to the output signal. The DC offset can be set between -200V and +200V. The total output (amplitude + offset) can not exceed $\pm 200V$.

MECHANICAL INFORMATION

TOP COVER REMOVAL

If necessary, the interior of the instrument may be accessed by removing the four Phillips screws on the top panel. With the four screws removed, the top cover may be slid back (and off).

Always disconnect the power cord before opening the instrument.

There are no user-adjustable internal circuits. For repairs other than fuse replacement, please contact Avtech (info@avtechpulse.com) to arrange for the instrument to be returned to the factory for repair.

 Caution: High voltages are present inside the instrument during normal operation. Do not operate the instrument with the cover removed.

RACK MOUNTING

A rack mounting kit is available. The -R5 rack mount kit may be installed after first removing the one Phillips screw on the side panel adjacent to the front handle.

ELECTROMAGNETIC INTERFERENCE

To prevent electromagnetic interference with other equipment, all used outputs should be connected to shielded loads using shielded coaxial cables. Unused outputs should be terminated with shielded terminators or with shielded dust caps, to prevent unintentional electromagnetic radiation. All cords and cables should be less than 3m in length.

MAINTENANCE

REGULAR MAINTENANCE

This instrument does not require any regular maintenance.

On occasion, one or more of the four rear-panel fuses may require replacement. All fuses can be accessed from the rear panel. See the “FUSES” section for details.

CLEANING

If desired, the interior of the instrument may be cleaned using compressed air to dislodge any accumulated dust. (See the “TOP COVER REMOVAL” section for instructions on accessing the interior.) No other cleaning is recommended.

OPERATIONAL CHECK

This section describes a sequence to confirm the basic operation of the instrument. It should be performed after receiving the instrument. It is a useful learning exercise as well.

Before proceeding with this procedure, finish reading this instruction manual thoroughly. Then read the “Local Control” section of the “Programming Manual for -B Instruments” thoroughly. The “Local Control” section describes the front panel controls used in this operational check - in particular, the MOVE, CHANGE, and ADJUST controls.

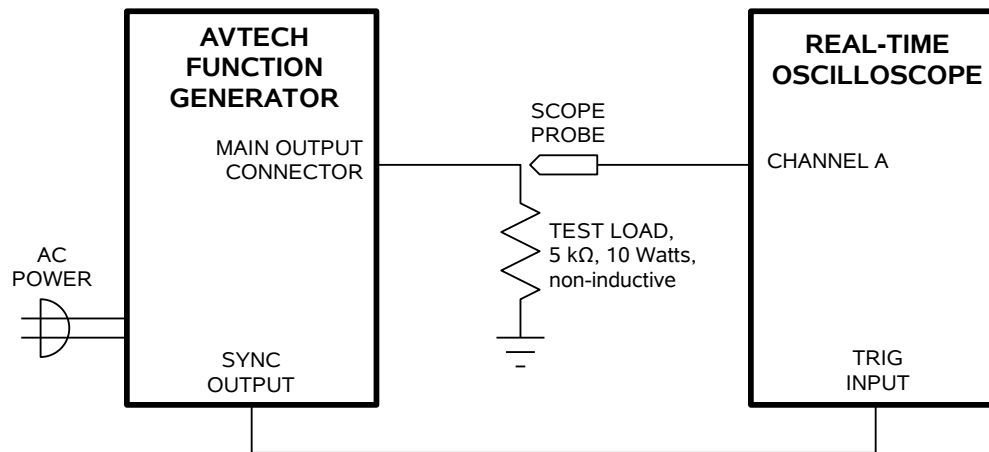

Basic Test Arrangement

1. Connect a non-inductive 5 kΩ, 10W test load between the OUT connector and ground. (Note: wirewound resistors are very inductive. Avoid them. Avtech suggests using five 1 kΩ Ohm, 2W Ohmite OY-series resistors (model OY102K) connected in parallel. See www.ohmite.com for information on OY resistors. These resistors may be purchased readily at www.digikey.com.) If desired, a higher-resistance, lower-power load may be used to simplify the test. The required load power rating for a given resistance is $40000 / R_{LOAD}$, where R_{LOAD} is in Ohms.

Confirm that the oscilloscope and the test load are rated for ± 200 Volt operation.

2. Connect a cable from the SYNC connector to the TRIG input of an oscilloscope. Set the oscilloscope to trigger externally.
3. Connect an oscilloscope probe to the load. On the oscilloscope, set the vertical scale to 100 V/div, and the horizontal scale to 20 us/div.
4. Turn on the AV-153A-B. The main menu will appear on the LCD.

5. To set the AV-153A-B to trigger from the internal clock at a PRF of 30 kHz:
 - a) The arrow pointer should be pointing at the frequency menu item. If it is not, press the MOVE button until it is.
 - b) Press the CHANGE button. The frequency submenu will appear. Rotate the ADJUST knob until the frequency is set at 30 kHz.
 - c) Press CHANGE to return to the main menu.
6. To set the waveshape to a sinusoid:
 - a) Press the MOVE button until the arrow pointer is pointing at the shape menu item.
 - b) Press the CHANGE button. The delay submenu will appear.
 - c) Press MOVE until the arrow pointer is pointing at the "SINE" choice.
 - d) Press CHANGE to return to the main menu.
7. At this point, nothing should appear on the oscilloscope.
8. To enable the output:
 - a) Press the MOVE button until the arrow pointer is pointing at the output menu item.
 - b) Press the CHANGE button. The output submenu will appear.
 - c) Press MOVE until the arrow pointer is pointing at the "ON" choice.
 - d) Press CHANGE to return to the main menu.
9. To change the output amplitude:
 - a) Press the MOVE button until the arrow pointer is pointing at the amplitude menu item.
 - b) Press the CHANGE button. The amplitude submenu will appear. Rotate the ADJUST knob until the amplitude is set at +200V.
 - c) Observe the oscilloscope. You should see a 30 kHz, 200V peak (400V peak-to-peak) sine wave.
 - d) Press CHANGE to return to the main menu.

This completes the operational check.

If additional assistance is required:

Tel: (613) 226-5772

Fax: (613) 226-2802

Email: info@avtechpulse.com

PROGRAMMING YOUR PULSE GENERATOR

KEY PROGRAMMING COMMANDS

The “Programming Manual for -B Instruments” describes in detail how to connect the pulse generator to your computer, and the programming commands themselves. A large number of commands are available; however, normally you will only need a few of these. Here is a basic sample sequence of commands that might be sent to the instrument after power-up, using the internal trigger source:

```
*rst                (resets the instrument)
sour:func sin      (selects a sine wave output)
frequency 1000 Hz  (sets the frequency to 1000 Hz)
output on         (turns on the output)
volt 50           (sets the amplitude to 50 V)
volt:low -100     (sets the offset to +10 V)
```

To generate a pulse output, use:

```
*rst                (resets the instrument)
sour:func pulse    (selects a unipolar pulse output)
frequency 1000 Hz  (sets the frequency to 1000 Hz)
pulse:width 10 us  (sets the pulse width to 10 us)
pulse:delay 1 us   (sets the delay to 1 us)
output on         (turns on the output)
volt 50           (sets the amplitude to 50 V)
volt:low -100     (sets the offset to -100 V)
```

To amplify an external signal, use:

```
*rst                (resets the instrument)
sour:func amp      (enables the amplifier mode)
output on         (turns on the output)
volt 150          (sets the gain to  $150 / 2 = 75$ )
volt:low -100     (sets the offset to -100 V)
```

These commands will satisfy 90% of your programming needs.

ALL PROGRAMMING COMMANDS

For more advanced programmers, a complete list of the available commands is given below. These commands are described in detail in the “Programming Manual for -B Instruments”. (Note: this manual also includes some commands that are not implemented in this instrument. They can be ignored.)

<u>Keyword</u>	<u>Parameter</u>	<u>Notes</u>
LOCAL		
OUTPut:		
:[STATe]	<boolean value>	
:PROTection		
:TRIPped?		[query only]
REMOTE		
[SOURce]:		
:FREQuency		
[:CW FIXed]	<numeric value>	
:FUNCTion		
:[SHAPE]	AMPLify PULSe SINusoid SQUare TRIangle	
:PULSe		
:PERiod	<numeric value>	
:WIDTh	<numeric value> IN	
:DELay	<numeric value>	
:VOLTagE		
[:LEVel]		
[:IMMediate]		
[:AMPLitude]	<numeric value>	
:LOW	<numeric value>	
:PROTection		
:TRIPped?		[query only]
STATUS:		
:OPERation		
:[EVENT]?		[query only, always returns "0"]
:CONDition?		[query only, always returns "0"]
:ENABle	<numeric value>	[implemented but not useful]
:QUESTionable		
:[EVENT]?		[query only, always returns "0"]
:CONDition?		[query only, always returns "0"]
:ENABle	<numeric value>	[implemented but not useful]
SYSTem:		
:COMMunicate		
:GPIB		
:ADDReSS	<numeric value>	
:SERial		
:CONTRol		
:RTS	ON IBFull RFR	
:[RECeive]		
:BAUD	1200 2400 4800 9600	
:BITS	7 8	
:ECHO	<boolean value>	
:PARity		
:[TYPE]	EVEN ODD NONE	
:SBITS	1 2	
:ERRor		
:[NEXT]?		[query only]

:COUNT?		[query only]
:VERSion?		[query only]
TRIGger:		
:SOURce	INTernal EXTernal MANual HOLD IMMEDIATE	
*CLS		[no query form]
*ESE	<numeric value>	
*ESR?		[query only]
*IDN?		[query only]
*OPC		
*SAV	0 1 2 3	[no query form]
*RCL	0 1 2 3	[no query form]
*RST		[no query form]
*SRE	<numeric value>	
*STB?		[query only]
*TST?		[query only]
*WAI		[no query form]

OTHER INFORMATION

APPLICATION NOTES

Application notes are available on the Avtech web site, at <http://www.avtechpulse.com/appnote>.

MANUAL FEEDBACK

Please report any errors or omissions in this manual, or suggestions for improvement, to info@avtechpulse.com. Thanks!

WIRING DIAGRAMS

WIRING OF AC POWER

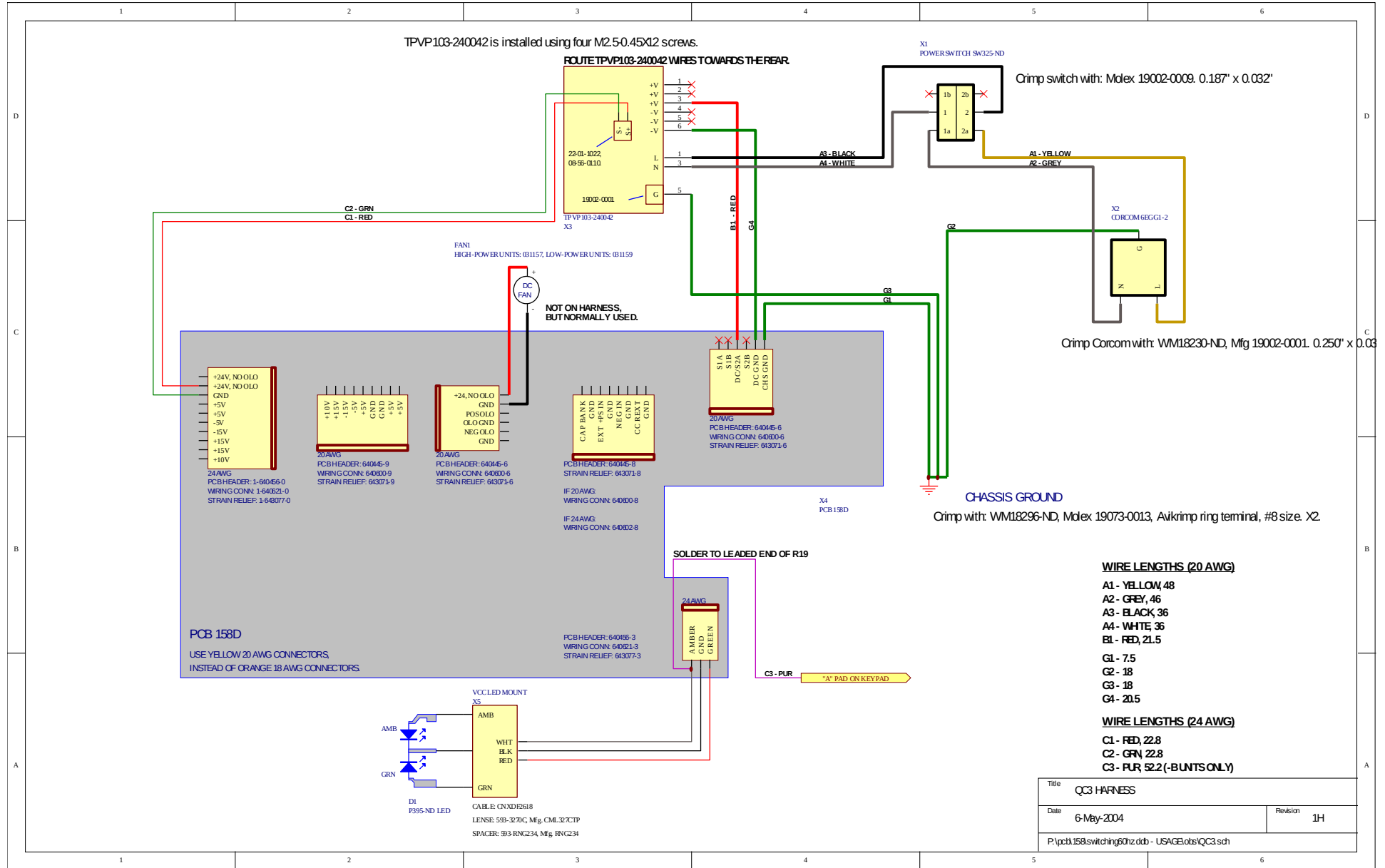

PCB 158D - LOW VOLTAGE POWER SUPPLY, 1/3

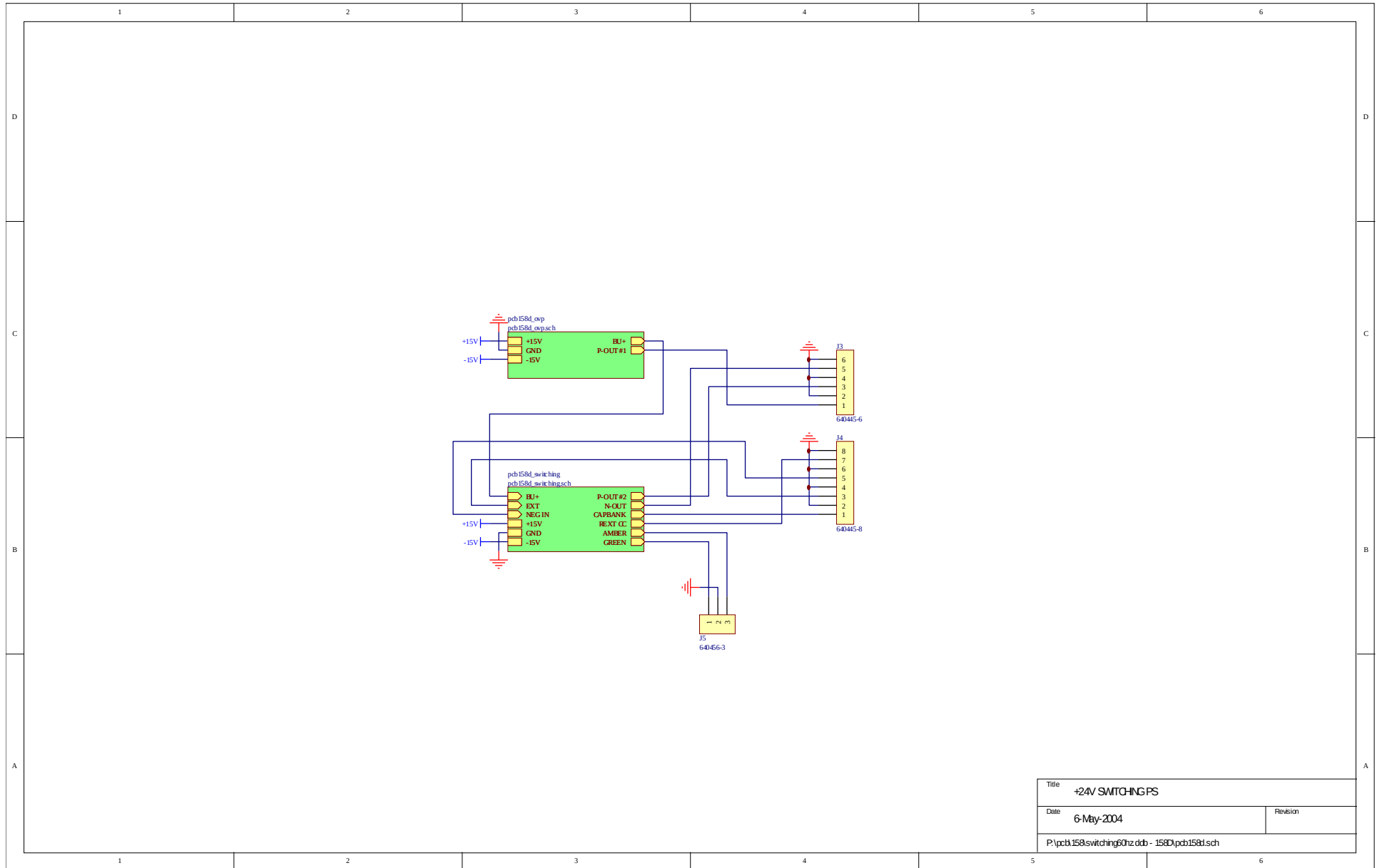

Title	+24V SWITCHINGPS	
Date	6-May-2004	Revision
P:\pcb158switching60hz.dcb - 158D\pcb158d1.sch		

PCB 158D - LOW VOLTAGE POWER SUPPLY, 2/3

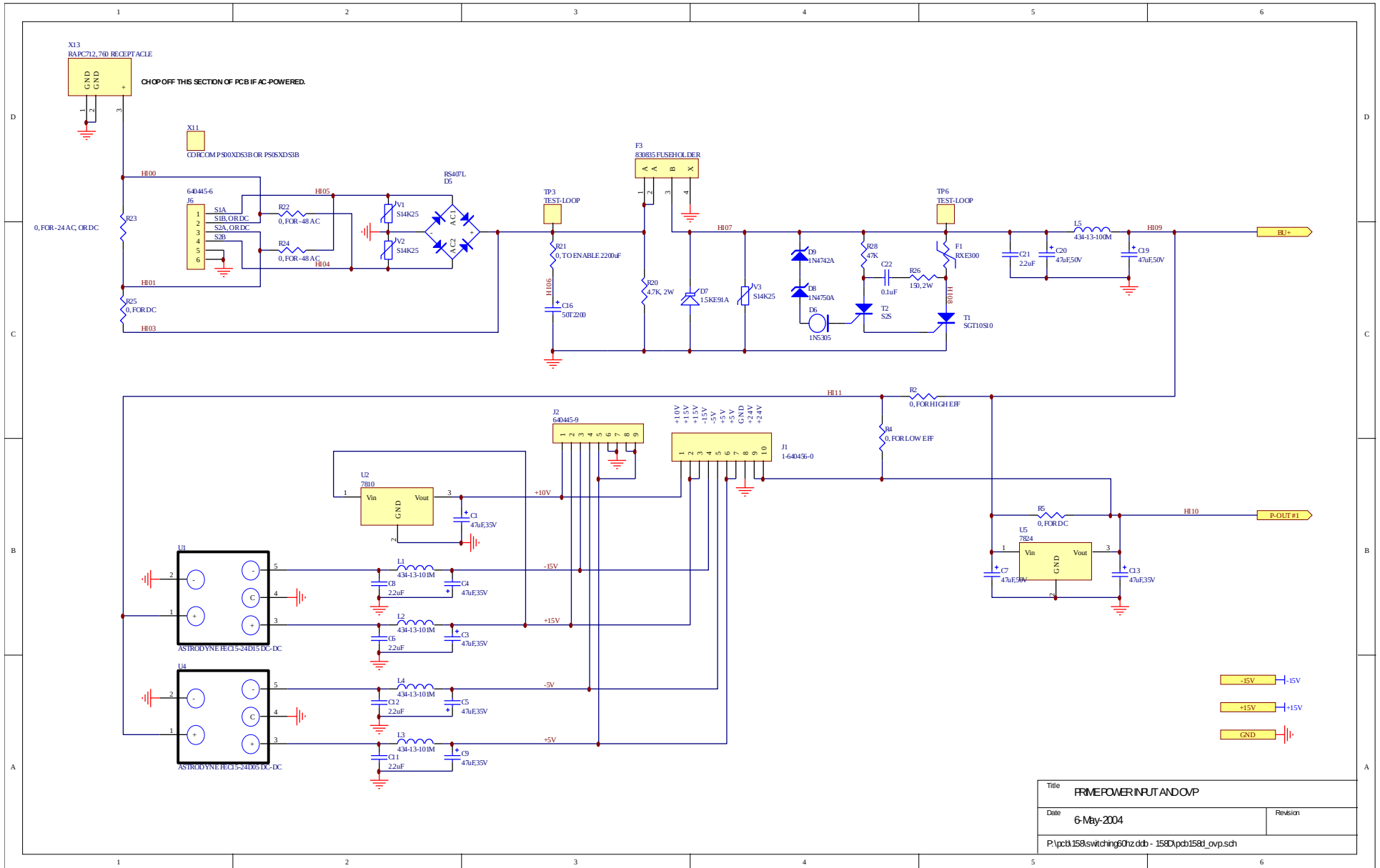

PCB 158D - LOW VOLTAGE POWER SUPPLY, 3/3

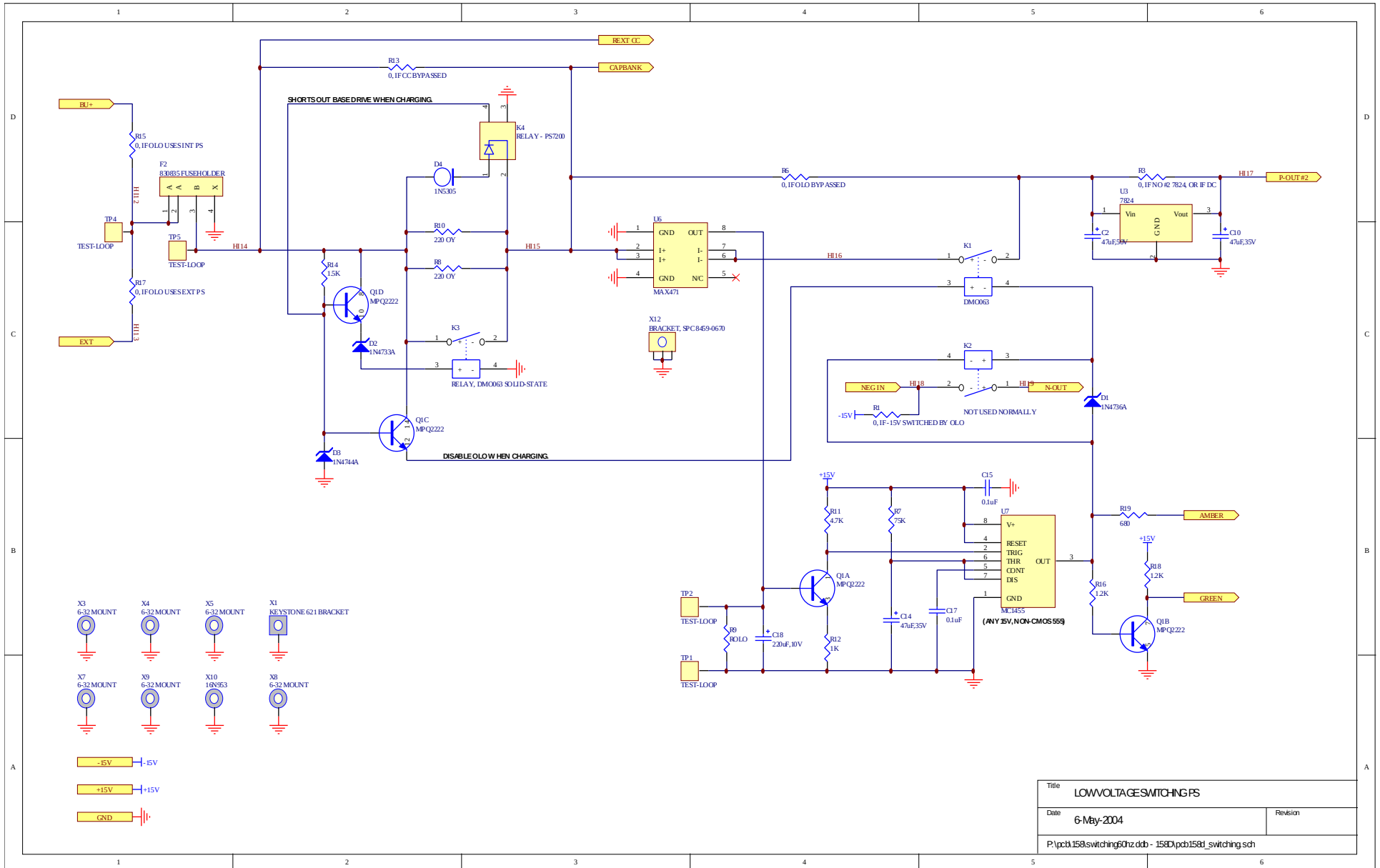

HIGH-VOLTAGE DC POWER SUPPLIES

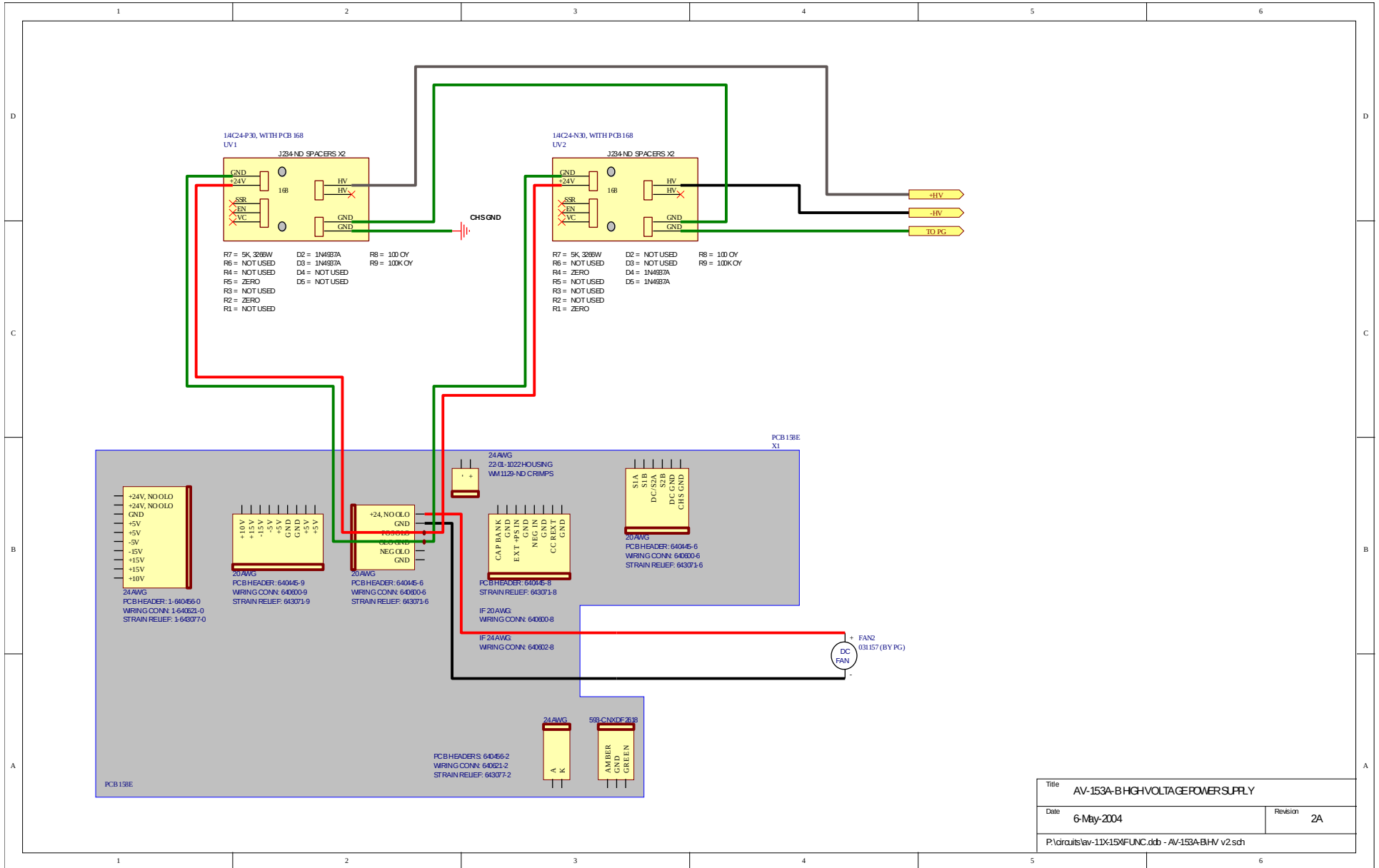

Title AV-153A-B HIGH-VOLTAGE POWER SUPPLY	
Date 6-May-2004	Revision 2A
P:\circuits\av-11x15\FUNC.dtb - AV-153A-BHV v2.sch	

WIRING OF TIMING BOARDS

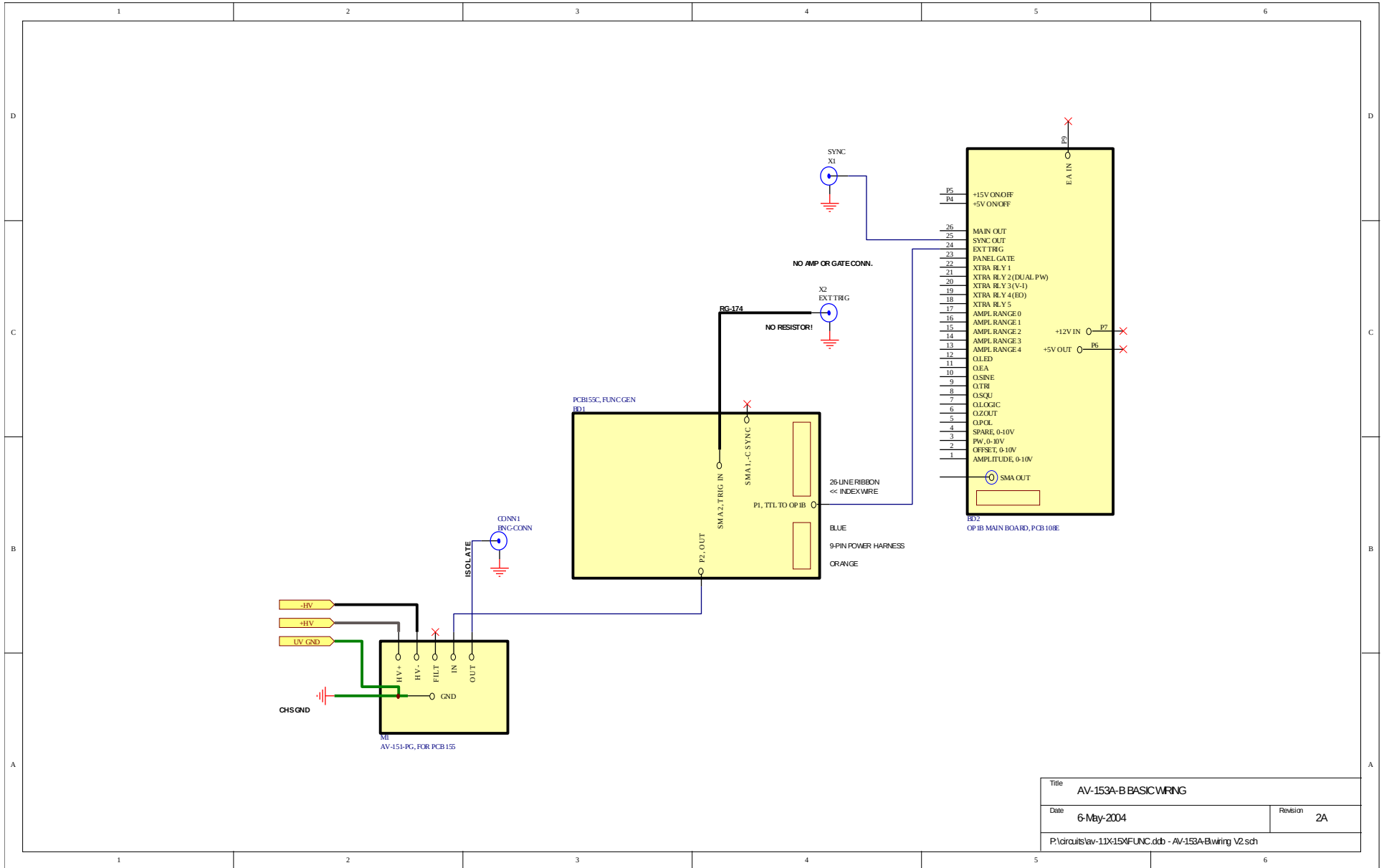

Title	AV-153A-B BASIC WIRING	
Date	6-May-2004	Revision 2A
P:\circuits\lav-11X15XFUNC.ddb - AV-153A-B wiring V2.sch		

PERFORMANCE CHECK SHEET