

INSTRUCTIONS

MODEL AV-155-P-B-UCA

0 to +200 mA AMPLITUDE, 0 to +200 mA OFFSET,
0 to +4V COMPLIANCE, 10 ns RISE TIME

PULSED CONSTANT CURRENT GENERATOR

WITH IEEE 488.2 AND RS-232 CONTROL

SERIAL NUMBER: _____

WARRANTY

Avtech Electrosystems Ltd. warrants products of its manufacture to be free from defects in material and workmanship under conditions of normal use. If, within one year after delivery to the original owner, and after prepaid return by the original owner, this Avtech product is found to be defective, Avtech shall at its option repair or replace said defective item. This warranty does not apply to units which have been disassembled, modified or subjected to conditions exceeding the applicable specifications or ratings. This warranty is the extent of the obligation assumed by Avtech with respect to this product and no other warranty or guarantee is either expressed or implied.

TECHNICAL SUPPORT

Phone: 613-226-5772 or 1-800-265-6681

Fax: 613-226-2802 or 1-800-561-1970

E-mail: info@avtechpulse.com

World Wide Web: <http://www.avtechpulse.com>

TABLE OF CONTENTS

WARRANTY	2
TECHNICAL SUPPORT	2
TABLE OF CONTENTS	3
INTRODUCTION	5
SPECIFICATIONS	7
INSTALLATION	8
VISUAL CHECK	8
PLUGGING IN THE INSTRUMENT	8
FRONT PANEL CONTROLS	9
REAR PANEL CONTROLS	11
GENERAL INFORMATION - PULSE GENERATOR OPERATION	13
BASIC PULSE TIMING CONTROL	13
BASIC PULSE AMPLITUDE CONTROL	14
TRIGGER MODES	15
GATING MODES	16
PULSE-TO-PULSE AMPLITUDE CONTROL	17
GENERAL INFORMATION - AMPLIFIER OPERATION	18
AMPLIFIER MODE	18
CONNECTING THE LOAD FOR OPTIMUM PERFORMANCE	19
LOAD AND INSTRUMENT PROTECTION	20
LENZ'S LAW AND INDUCTIVE VOLTAGE SPIKES	20
OUTPUT ON/OFF	20
ATTACHING AND DETACHING LOADS	20
OPEN AND SHORT CIRCUITS	20
OPERATIONAL CHECK	22
CALIBRATION ADJUSTMENTS - INTERNAL TRIMPOTS	26
NULLING CONSTANT CURRENT OFFSETS	26
NULLING AMPLITUDE-DEPENDENT CURRENT OFFSETS	27
NULLING CONSTANT MONITOR OFFSETS	27
ADJUSTING OUTPUT IMPEDANCE	27
ADJUSTING MONITOR CALIBRATION	27
CALIBRATION ADJUSTMENTS - SOFTWARE PROCEDURES	28
ADJUSTING AMPLITUDE ACCURACY	28

	4
<i>MECHANICAL INFORMATION</i>	29
<i>TOP COVER REMOVAL</i>	29
<i>RACK MOUNTING</i>	29
<i>PROGRAMMING YOUR PULSE GENERATOR</i>	30
<i>KEY PROGRAMMING COMMANDS</i>	30
<i>ALL PROGRAMMING COMMANDS</i>	32
<i>PERFORMANCE CHECK SHEET</i>	34

INTRODUCTION

The Model AV-155-P-B-UCA pulsed constant current generator is capable of producing pulses with amplitudes as high as +200 mA into load voltages up to +4V, with 10 ns rise and fall times. A DC offset in the range of 0 to +200 mA may be added to the pulse output. The internal trigger source can be used to trigger the instrument at frequencies between 0.1 Hz and 10 MHz. An external TTL trigger pulse, a front-panel pushbutton, and a computer can also be used to trigger the instrument.

This instrument has two output channels. The pulses on one channel may be delayed up to $\pm 10 \mu\text{s}$ with respect to the pulses on the other channel.

The AV-155-P-B-UCA offers very flexible control of triggering and amplitude. Several trigger modes are available:

- Internal Trigger Mode - the instrument is triggered by its own internal oscillator. The repetition rate can be set using the front-panel or with a computer command.
- Manual Trigger Mode: the instrument is triggered by the front-panel "SINGLE PULSE" pushbutton.
- Immediate Trigger: generates a single trigger event in response to a computer command. This is the computer-control equivalent of pressing the front-panel "SINGLE PULSE" pushbutton.
- Hold Trigger Mode: the instrument is set to not trigger at all.
- External Trigger Mode: the instrument is triggered by an external TTL-level clock on the back-panel TRIG connector.

In each of the above modes, the output amplitude, pulse width, and delay can be controlled by the front-panel keypad, or by computer commands. However, in any of the above modes, the amplitude can also be set by an external modulation signal. In this mode, the output amplitude is approximately equal to $I_{\text{OUT}} \cong V_{\text{AMP}} \times 25 \text{ mA/V}$ (for the duration of the set pulse width), where V_{AMP} is the modulation input. The input signal affects only the output amplitude, and not the repetition rate, delay, or pulse width.

One last mode is also available: the amplifier mode. In this mode, the instrument acts strictly as an amplifier, and $I_{\text{OUT}} \cong V_{\text{AMP}} \times 50 \text{ mA/V}$. The delay, repetition rate, and pulse width are controlled entirely by the input signal.

The Model AV-155-P-B-UCA pulse generator is a current pulser. The current amplitude is largely independent of the load voltage. For proper operation, the load voltage ($V_{\text{LOAD}} = I_{\text{LOAD}} \times R_{\text{LOAD}}$) must lie in the range of 0 to +4V.

The AV-155-P-B-UCA features front panel keyboard and adjust knob control of the output pulse parameters along with a four line by 40 character back-lit LCD display of the output amplitude, pulse width, pulse repetition frequency, and delay. The instrument includes memory to store up to four complete instrument setups. The operator may use the front panel or the computer interface to store a complete "snapshot" of all key instrument settings, and recall this setup at a later time.

SPECIFICATIONS

Model:	AV-155-P-B-UCA
Amplitude:	Pulse: 0 to +200 mA, DC Offset: 0 to +200 mA, Peak: +400 mA, for load voltages of 0 to +4 Volts
Channels:	Two
Pulse width:	20 ns to 2 μ s
Rise time:	\leq 10 ns
Fall time:	\leq 10 ns
PRF:	internal trigger: 0.1 Hz to 10 MHz external or pushbutton trigger: 0 to 10 MHz
Max. duty cycle:	Internal trigger: 90% External trigger: 100%
Output current regulation:	\leq 1% for load change from 0V to 3V
Trigger required: (external trigger mode)	50 ns or wider (TTL)
Monitor output:	Provides an attenuated coincident replica of the main output current pulse. $V_{MON} \cong I_{LOAD} \times 7.7 \Omega$
Inter-channel delay:	0 to 10 μ s
Sync output:	+ 3 Volts, 50 ns wide, will drive 50 Ohm loads
Connectors:	Out: LZ3 socket, Gate, Trig, Sync, Monitor: BNC
Power, AC:	120/240 Volts (switchable) 50 - 60 Hz
Dimensions:	3.9" x 17" x 14.8"
Chassis material:	anodized aluminum, with blue plastic trim
Mounting:	Any
Temperature range:	+ 10° to + 40° C

INSTALLATION

VISUAL CHECK

After unpacking the instrument, examine to ensure that it has not been damaged in shipment. Visually inspect all connectors, knobs, liquid crystal displays (LCDs), and the handles. Confirm that a power cord and two instrumentation manuals (this manual and the "OP1B Interface Programming Manual") are with the instrument. If the instrument has been damaged, file a claim immediately with the company that transported the instrument.

PLUGGING IN THE INSTRUMENT

Examine the rear of the instrument. There will be a male power receptacle, a fuse holder and the edge of the power selector card visible. Confirm that the power selector is in the correct orientation - it should be marked either 120 or 240, indicating whether it expects 120V AC or 240V AC. If it is not set for the proper voltage, remove the fuse and then grasp the card with a pair of pliers and remove it. Rotate horizontally through 180 degrees. Reinstall the card and the correct fuse. In the 120V setting, a 1A slow blow fuse is required. In the 240V setting, a 1/2A slow blow fuse is required.

FRONT PANEL CONTROLS

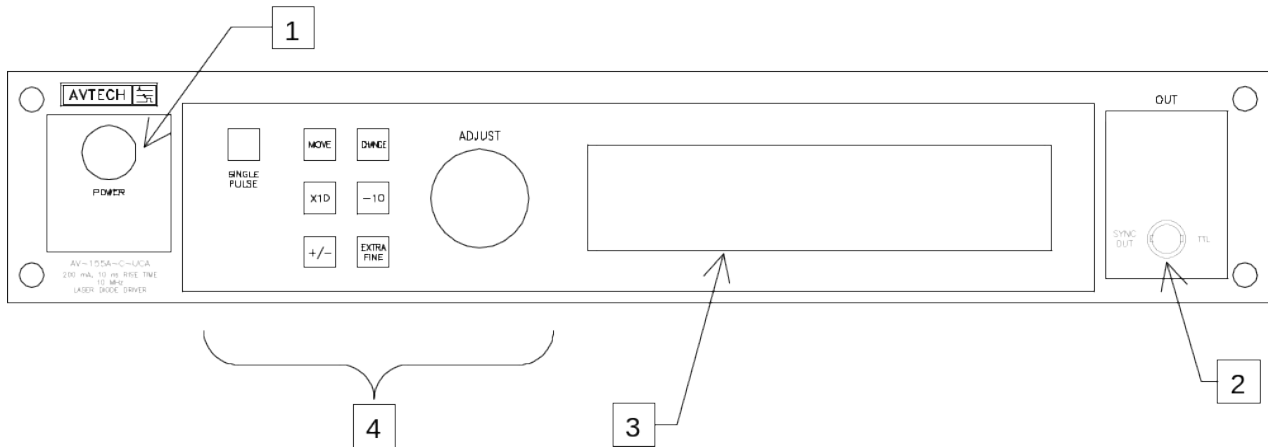

1. **POWER Switch**. The POWER push button switch applies AC prime power to the primaries of the transformer, turning the instrument on. The push button lamp (#382 type) is connected to the +15V DC supply.
2. **SYNC OUT**. This connector supplies a SYNC output that can be used to trigger other equipment, particularly oscilloscopes. This pulse is coincident with pulses on Channel 2. The sync output has an approximate amplitude of +3 Volts to $R_L > 1K$ with a pulse width of approximately 50 ns.
3. **LIQUID CRYSTAL DISPLAY (LCD)**. This LCD is used in conjunction with the keypad to change the instrument settings. Normally, the main menu is displayed, which lists the key adjustable parameters and their current values. The "OP1B Interface Programming Manual" describes the menus and submenus in detail.
4. **KEYPAD**.

Control Name	Function
MOVE	This moves the arrow pointer on the display.
CHANGE	This is used to enter the submenu, or to select the operating mode, pointed to by the arrow pointer.
×10	If one of the adjustable numeric parameters is displayed, this increases the setting by a factor of ten.
÷10	If one of the adjustable numeric parameters is displayed, this decreases the setting by a factor of ten.
+/-	If one of the adjustable numeric parameters is displayed, and this parameter can be both positive or negative, this changes the sign of the parameter.
EXTRA FINE	This changes the step size of the ADJUST knob. In the extra-fine mode, the step size is twenty times finer than in the normal mode. This button switches between the two step sizes.
ADJUST	This large knob adjusts the value of any displayed numeric adjustable values, such as frequency, pulse width, etc. The

	<p>adjust step size is set by the "EXTRA FINE" button.</p> <p>When the main menu is displayed, this knob can be used to move the arrow pointer.</p>
--	---

REAR PANEL CONTROLS

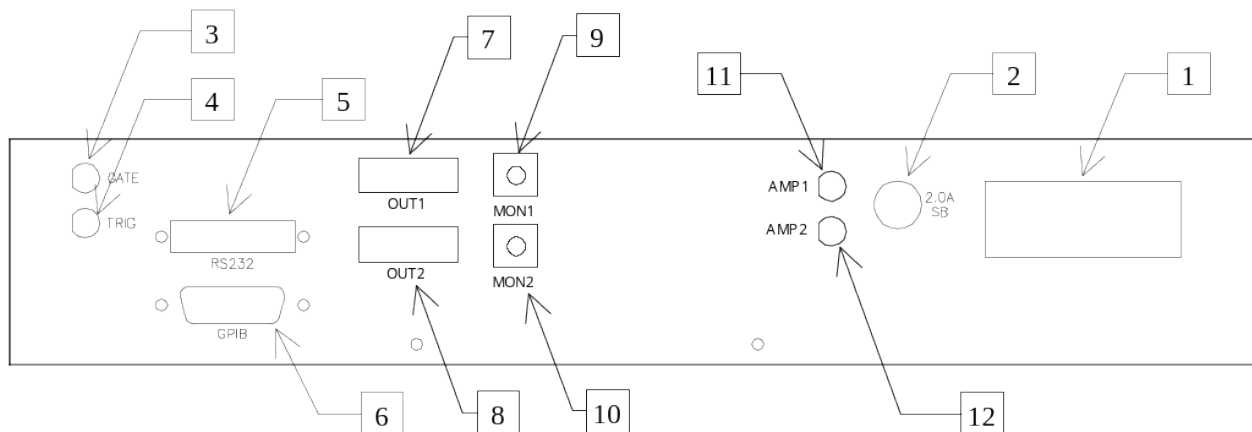

1. **AC POWER INPUT.** A three-pronged recessed male connector is provided on the back panel for AC power connection to the instrument. Also contained in this assembly is a 2.0A slow blow fuse and a removable card that can be removed and repositioned to switch between 120V AC in and 240V AC in.
2. **2.0A SB.** This fuse protects the internal +15V DC power supply.
3. **GATE.** This TTL-level (0 and +5V) logic input can be used to gate the triggering of the instrument. This input can be either active high or active low, depending on the front panel settings or programming commands. (The instrument triggers normally when this input is unconnected).
4. **TRIG.** This TTL-level (0 and +5V) logic input can be used to trigger the instrument, if the instrument is set to triggering externally. The instrument triggers on the rising edge of this input.
5. **RS-232 Connector.** A standard serial cable with a 25-pin male connector can be attached to this connector to allow the instrument to be computer-controlled. See the "OP1B Interface Programming Manual" for more details on RS-232 control.
6. **GPIB Connector.** A standard GPIB cable can be attached to this connector to allow the instrument to be computer-controlled. See the "OP1B Interface Programming Manual" for more details on GPIB control.
7. **OUT1.** This is the Channel 1 output. The LZ3 transmission line or the RG174 transmission line plugs into this socket. The upper side of the socket ("UP") is the signal line. The lower side ("DOWN") is connected to ground.
8. **OUT2.** This is the Channel 2 output. The LZ3 transmission line or the RG174 transmission line plugs into this socket. The upper side of the socket ("UP") is the signal line. The lower side ("DOWN") is connected to ground.
9. **MON1.** This is the current monitor output for Channel 1. This output provides a voltage waveform that is proportional to the current waveform on the Channel 1

output. The monitor relationship is approximately: $V_{MON1} \cong 7.7\Omega \times I_{OUT1}$, for a load of $> 1\text{ k}\Omega$. (The monitor output can also drive a 50Ω load, but the output voltage will be reduced by a factor of two. This output is short-circuit protected.)

10. MON2. This is the current monitor output for Channel 2. This output provides a voltage waveform that is proportional to the current waveform on the Channel 1 output. The monitor relationship is approximately: $V_{MON1} \cong 7.7\Omega \times I_{OUT1}$, for a load of $> 1\text{ k}\Omega$. (The monitor output can also drive a 50Ω load, but the output voltage will be reduced by a factor of two. This output is short-circuit protected.)
11. AMP1. This connector has two functions. The amplitude of the Channel 1 output can be controlled by a modulation voltage (0 to +10V) on this input. In this mode, 0V in produces zero amplitude out. +10V produces the maximum amplitude. Also, this input can be used as the amplifier input in the amplify mode. In this case, the Channel 1 output current is proportional to the input voltage waveform. Note that this input is terminated into 50Ω .
12. AMP2. This connector has two functions. The amplitude of the Channel 2 output can be controlled by a modulation voltage (0 to +10V) on this input. In this mode, 0V in produces zero amplitude out. +10V produces the maximum amplitude. Also, this input can be used as the amplifier input in the amplify mode. In this case, the Channel 2 output current is proportional to the input voltage waveform. Note that this input is terminated into 50Ω .

GENERAL INFORMATION - PULSE GENERATOR OPERATION

BASIC PULSE TIMING CONTROL

When used as a pulsed generator (as opposed to an amplifier), this instrument can be triggered by several sources - its own internal clock, an external TTL trigger signal, the front-panel "SINGLE PULSE" pushbutton, by a computer-generated command. In any case, five output channels respond to the trigger: OUT1, OUT2, SYNC, MON1, and MON2. OUT1 and OUT2 are the signals that are applied to the devices under test. Their amplitudes and pulse widths are variable. The SYNC pulse is a fixed-width TTL-level reference pulse used to trigger oscilloscopes or other measurement systems, and is coincident with the OUT2 pulse. The MON1 and MON2 outputs are voltage waveforms that are proportional to the current waveforms on OUT1 and OUT2, respectively. $V_{MON1} \cong 7.7\Omega \times I_{OUT1}$ and $V_{MON2} \cong 7.7\Omega \times I_{OUT2}$ for monitor loads of $> 1 \text{ k}\Omega$.

When the delay is set to a positive value the OUT2 and SYNC pulses precede the channel 1 pulse. This order is reversed for negative delays.

These pulses are illustrated below for a positive delay:

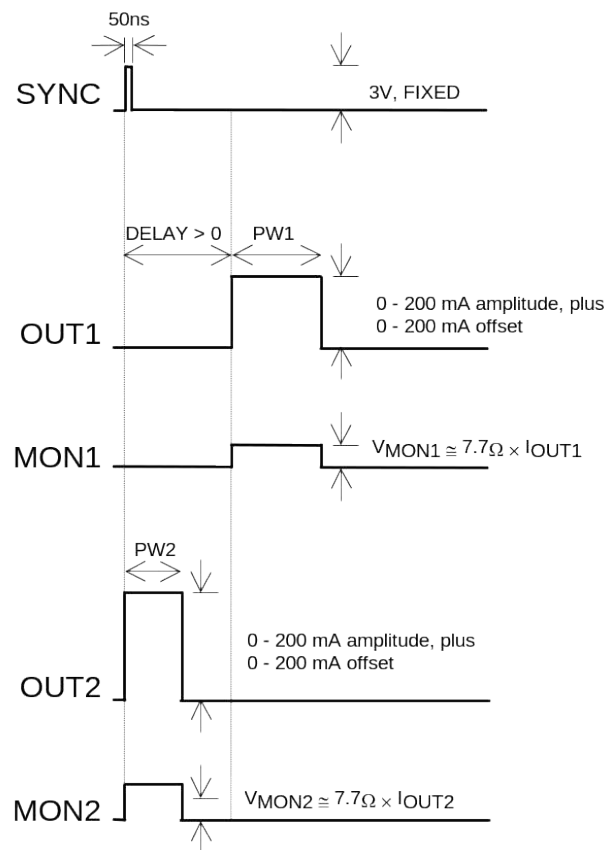

Basic Output Pulses for Delay > 0

The order of the output pulses is reversed for negative delays:

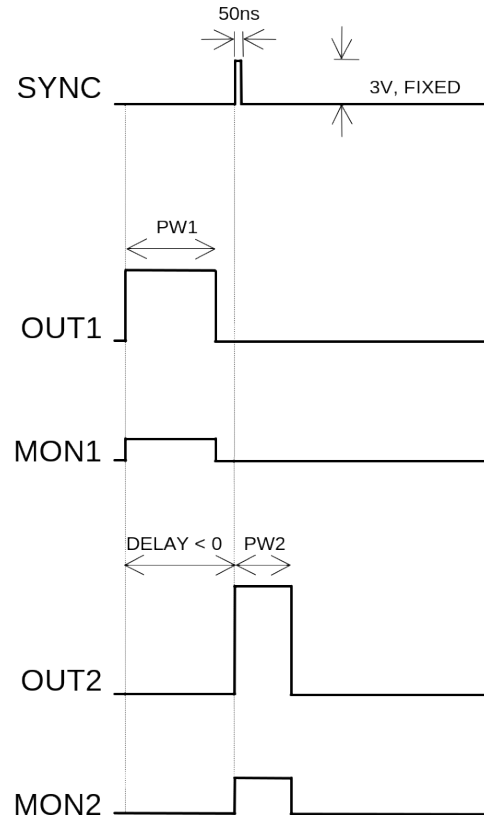

Basic Output Pulses for Delay < 0

The delay, pulse width, and frequency (when in the internal mode), of the OUT pulse can be varied with front panel controls or via the GPIB or RS-232 computer interfaces.

BASIC PULSE AMPLITUDE CONTROL

The amplitude of each channel can be controlled two ways:

1. By using the front-panel keypad or a computer command to set a specific value (e.g., 150 mA). The amplitude remains set as this value until the user changes it, i.e., the amplitude does not change pulse-to-pulse.
2. By using the modulation inputs (the connectors marked AMP1 and AMP2 on the rear panel.) This mode is activated by choosing the "Ext Control" mode from the amplitude control menu on the front-panel, or by using the "source:current external" programming command. This input has a +10V full-scale range. The bandwidth of this input is sufficiently fast that the amplitude can be changed for each pulse.

Example waveforms are shown below:

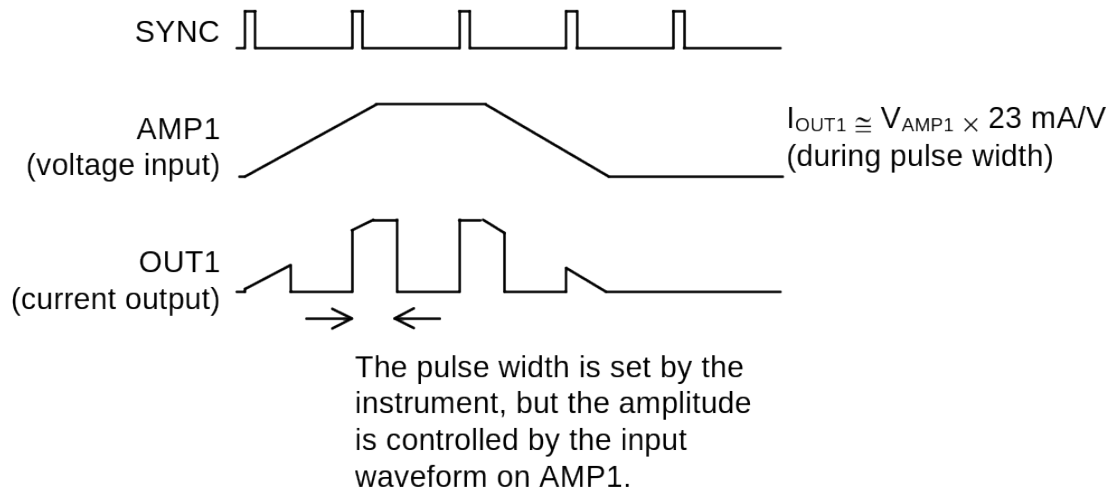

For more information on using this mode, see the "Pulse-to-Pulse Amplitude Control" section later in this manual.

TRIGGER MODES

This instrument has four front-panel trigger modes:

- **Internal Trigger:** the instrument controls the trigger frequency, and generates the clock internally.
- **External Trigger:** the instrument is triggered by an external TTL-level clock on the back-panel TRIG connector.
- **Manual Trigger:** the instrument is triggered by the front-panel "SINGLE PULSE" pushbutton.
- **Hold Trigger:** the instrument is set to not trigger at all.

These modes can be selected using the front panel trigger menu, or by using the appropriate programming commands. (See the "Source:Trigger" section of the "OP1B Interface Programming Manual" for more details.)

When being controlled by a computer, there is a fifth trigger mode:

- **Immediate Trigger:** generates a single trigger event. This is the computer-control equivalent of pressing the front-panel "SINGLE PULSE" pushbutton.

GATING MODES

Triggering can be suppressed by a TTL-level signal on the rear-panel GATE connector. The instrument can be set to stop triggering when this input high or low, using the front-panel gate menu or the appropriate programming commands.

This gate signal acts synchronously - i.e., when gated, the output will complete the full pulse width if the output is high, and then stop triggering. No pulses are truncated in this mode.

PULSE-TO-PULSE AMPLITUDE CONTROL

The modulation inputs are provided to give the user pulse-by-pulse control of the output amplitude, i.e., each consecutive pulse may have a different amplitude.

To achieve this in practice, the input modulation signal must be synchronized to the trigger source in some way. There are two basic approaches to achieving this:

- 1) Use an external trigger source. In this case, an external instrument (or a combination of them) supplies:
 - a) A TTL trigger signal, applied to the rear-panel TRIG input connector.
 - b) An analog modulation signal, applied to one of the modulation inputs (AMP1 and/or AMP2, as required).

In this case, the user must arrange for (a) and (b) to be properly synchronized.

- 2) Use one of the non-external trigger sources (i.e., internal trigger, pushbutton, or computer command), and use the SYNC output to trigger the modulation source.

Since the pulse generator generates a SYNC pulse whenever it is triggered, this pulse can be used to synchronize an external modulation source.

GENERAL INFORMATION - AMPLIFIER OPERATION

AMPLIFIER MODE

This instrument can also be used strictly as a voltage-to-current amplifier. In this case, the repetition rate, pulse width, waveform shape, and amplitude are all controlled by the input waveform. This mode is activated by choosing the "Ext Amplify" mode from the amplitude control menu on the front-panel, or by using the "source:current amplify" programming command. Example waveforms are shown below:

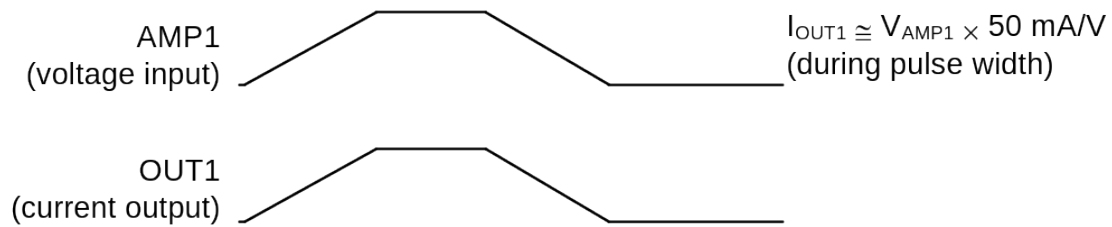

Note that in this case the SYNC output is not related in any way to the output waveform.

The AMP1 and AMP2 inputs are terminated in 50Ω .

CONNECTING THE LOAD FOR OPTIMUM PERFORMANCE

This instrument is supplied with two types of output cables, which can be plugged in the the OUT socket on the rear panel:

- A 6" RG174 coaxial transmission line, which has a 50Ω characteristic impedance (Z_0). For the best performance, the cable should be terminated with an impedance as close to 50Ω as is feasible.
- The LZ3 flexible flat transmission line, which has a 3Ω characteristic impedance (Z_0), and is terminated with a small circuit board.

For both cables, the end that plugs into the rear panel is marked with an "UP" side and a "DOWN" side. (The UP side is the signal output, and the DOWN side is ground.)

The end of the LZ3 line is illustrated below:

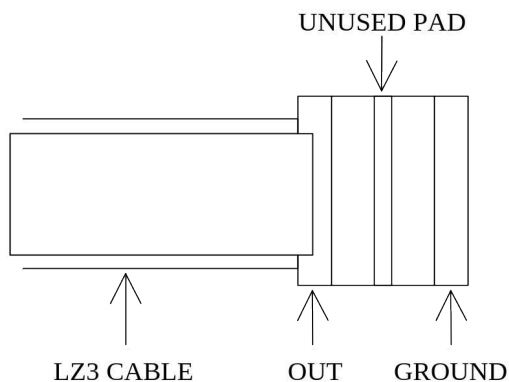

To connect a diode load, it should be soldered between the OUT and GROUND pads, as shown schematically below:

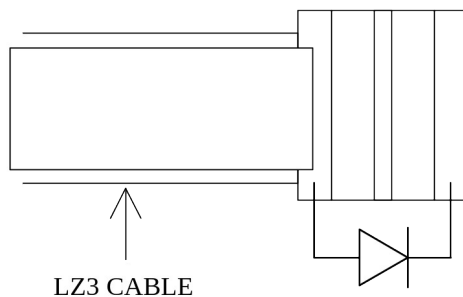

LOAD AND INSTRUMENT PROTECTION

LENZ'S LAW AND INDUCTIVE VOLTAGE SPIKES

This instrument is designed to pulse resistive and diode loads and will exhibit a large output spike when used to drive a load with significant inductance (as predicted by LENZ'S LAW). For this reason the load should be connected to the output using low inductance leads (as short as possible and as heavy a gauge as possible).

The voltage developed across an inductance L (in Henries), when the current is changing at a rate given by di_{LOAD}/dt (in Amps/sec), is: $V_{SPIKE} = L \frac{di_{LOAD}}{dt}$.

OUTPUT ON/OFF

The main outputs may be switched on and off using the front-panel controls or via programming commands. When the output is set "OFF", the main outputs are short-circuited to ground with a relay, and the trigger source is removed from the output stage.

ATTACHING AND DETACHING LOADS

To avoid damaging the loads connected to main outputs, the loads should only be connected to or removed from the instrument when:

- the instrument is off
- the instrument is on, but the outputs are turned off (i.e. the LCD display reads "OUTPUT OFF")

Do not connect loads when the instrument is on and the outputs are turned on. This can cause mild sparking.

CHANGING PARAMETERS WHEN A LOAD IS ATTACHED

If your load is easily damaged, the outputs should be turned off when changing the trigger source, frequency, pulse width, or other pulse parameters. This protects the loads from possible short transient effects.

OPEN AND SHORT CIRCUITS

The AV-155-P-B-UCA will operate properly into a short circuit to ground.

Operation into an open circuit will not damage the instrument in any way, although the monitor circuit may not give the correct reading (which should be zero).

AVOID EXCESS POWER DISSIPATION

To prolong the life of the output stages of the instrument, the internal power dissipation should be minimized whenever practical. The power dissipated in each of the two output stages can be calculated using:

$$P_{\text{DISS}} = (15\text{V} - V_{\text{LOAD}}) \times I_{\text{PEAK}} \times \text{Duty Cycle}$$

To minimize power dissipation, keep the current amplitude and duty cycle as low as practical. Operation into larger load resistance is preferred over operation into a low load resistance, since $V_{\text{LOAD}} = I_{\text{PEAK}} \times R_{\text{LOAD}}$.

OPERATIONAL CHECK

This section describes a sequence to confirm the basic operation of the instrument. It should be performed after receiving the instrument. It is a useful learning exercise as well.

Before proceeding with this procedure, finish reading this instruction manual thoroughly. Then read the “Local Control” section of the “OP1B Interface Programming Manual” thoroughly. The “Local Control” section describes the front panel controls used in this operational check - in particular, the MOVE, CHANGE, and ADJUST controls.

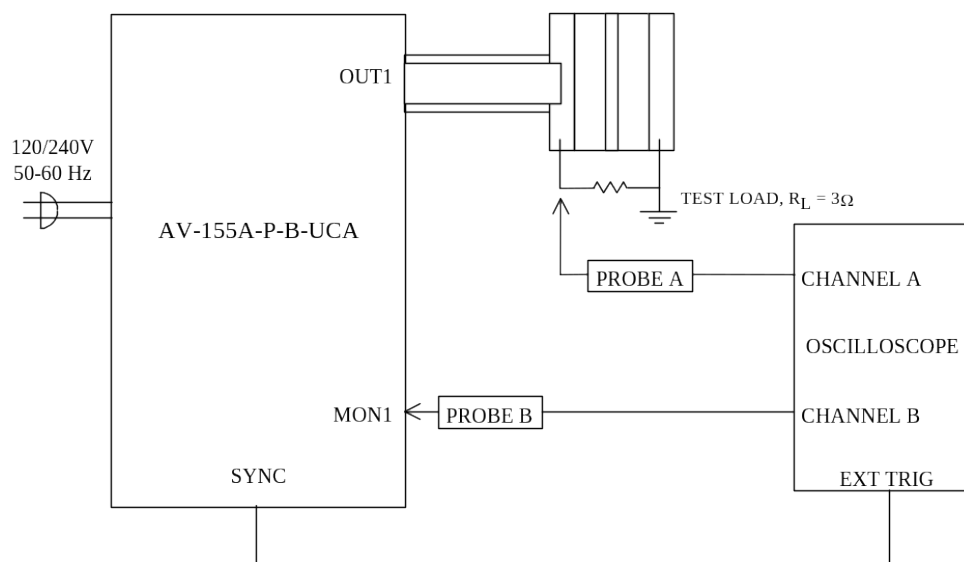

Basic Test Arrangement

- 1) Connect a low-inductance, 1/2W, 3Ω test load between the OUT1 connector and ground.
- 2) Connect a cable from the SYNC OUT connector to the TRIG input of an oscilloscope. Set the oscilloscope to trigger externally.
- 3) Connect one oscilloscope probe (channel A) to the OUT1 load. Connect the other probe to the MON1 output (on the rear panel). On the oscilloscope, set the channel A vertical scale to 1 V/div, the channel B vertical scale to 1 V/div, and the horizontal scale to 1 μs/div.
- 4) Turn on the AV-155-P-B-UCA. The main menu will appear on the LCD.
- 5) To set the AV-155-P-B-UCA to trigger from the internal clock at a PRF of 10 kHz:

- The arrow pointer should be pointing at the frequency menu item. If it is not, press the MOVE button until it is.
 - Press the CHANGE button. The frequency submenu will appear. Rotate the ADJUST knob until the frequency is set at 10 kHz.
 - The arrow pointer should be pointing at the “Internal” choice. If it is not, press MOVE until it is.
 - Press CHANGE to return to the main menu.
- 6) To set the delay to 1 μ s:
- Press the MOVE button until the arrow pointer is pointing at the delay menu item.
 - Press the CHANGE button. The delay submenu will appear. Rotate the ADJUST knob until the delay is set at 1 μ s.
 - Press CHANGE to return to the main menu.
- 7) To set the OUT1 pulse width to 1.5 μ s:
- Press the MOVE button until the arrow pointer is pointing at the “PW1” menu item.
 - Press the CHANGE button. The pulse width submenu will appear. Rotate the ADJUST knob until the pulse width is set at 1.5 μ s.
 - The arrow pointer should be pointing at the “Normal” choice. If it is not, press MOVE until it is.
 - Press CHANGE to return to the main menu.
- 8) To set the OUT2 pulse width to 2 μ s:
- Press the MOVE button until the arrow pointer is pointing at the “PW2” menu item.
 - Press the CHANGE button. The pulse width submenu will appear. Rotate the ADJUST knob until the pulse width is set at 2 μ s.

- The arrow pointer should be pointing at the “Normal” choice. If it is not, press MOVE until it is.
- Press CHANGE to return to the main menu.

9) At this point, nothing should appear on the oscilloscope.

10) To enable the output:

- Press the MOVE button until the arrow pointer is pointing at the output menu item.
- Press the CHANGE button. The output submenu will appear.
- Press MOVE until the arrow pointer is pointing at the “ON” choice.
- Press CHANGE to return to the main menu.

11) To change the OUT1 output amplitude:

- Press the MOVE button until the arrow pointer is pointing at the AMP1 menu item.
- Press the CHANGE button. The amplitude submenu will appear. Rotate the ADJUST knob until the amplitude is set at 100 mA.
- Observe the oscilloscope. You should see 1.5 μ s wide, 0.3V pulses (i.e., 100 mA \times 3 Ω = 0.3V) on the probe connected to the OUT1 main output. The other probe, connected to the MON1 monitor output, should also show 1.5 μ s, .77V pulses (i.e. 100 mA \times 7.7 V/A).
- Press CHANGE to return to the main menu.

12) Try varying the pulse width, by repeating step (7). As you rotate the ADJUST knob, the pulse width on the oscilloscope will change. Note that the maximum pulse width is 2 μ s.

13) Move the 3 Ω load and the oscilloscope probes from OUT1 and MON1 to OUT2 and MON2, respectively, and repeat steps 12 and 13 using the AMP2 and PW2 menus to change the second channel output.

14) This completes the operational check.

If additional assistance is required:

Tel: (613) 226-5772, Fax: (613) 226-2802
Email: info@avtechpulse.com

CALIBRATION ADJUSTMENTS - INTERNAL TRIMPOTS

Each output channel has five trimming potentiometers ("trimpots") that can be used to adjust the performance of the output channels. These trimpots are preset at the factory and should not normally require adjusting after delivery. These controls can be accessed by removing the top panel of the instrument, and by locating the two identical output-stage modules. When looking from the front of the instrument, the channel 1 module is on the left and the channel 2 module is on the right. Both are near the rear of the instrument.

The locations of the trimpots (designated TP1-TP5) for each channel are shown below. All should be accessible through the heatsinking.

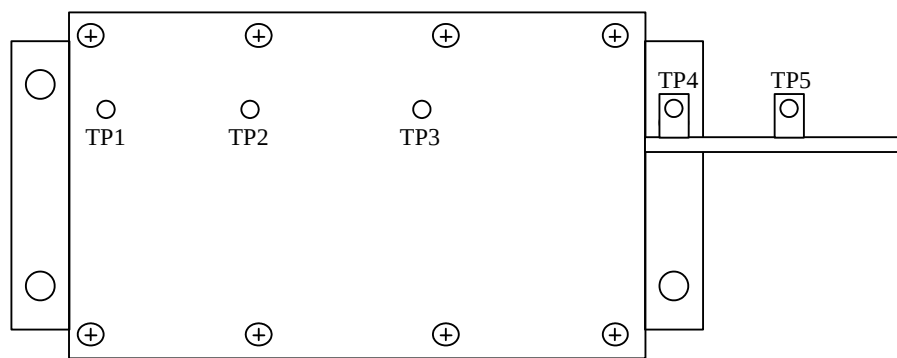

Location of Trimpots

These trimpots can be used to adjust or calibrate the following properties for each channel:

- Current offsets on the main outputs.
- Voltage offsets on the monitor outputs.
- Monitor calibration.
- Channel output impedance.

NULLING CONSTANT CURRENT OFFSETS

If a small constant current offset is observed on one of the main outputs, TP2 can be rotated to reduce it to zero. Note that the output stage is incapable of generating a negative current, due to the presence of a diode in series with the output.

NULLING AMPLITUDE-DEPENDENT CURRENT OFFSETS

If a small amplitude-dependent current offset is observed on one of the main outputs, TP1 can be rotated to null it out. Rotate TP1 while adjusting the output amplitude from the front panel, until the offset does not vary with amplitude.

NULLING CONSTANT MONITOR OFFSETS

If a small constant voltage offset is observed on one of the monitor outputs, TP5 can be rotated to reduce it to zero.

ADJUSTING OUTPUT IMPEDANCE

Ideally, the outputs of the pulsed current sources should be independent of the output voltages, within the 0 to +4V compliance voltage range. This condition represents infinite output impedance. If a load voltage/output current dependence is present, the output impedance needs to be adjusted.

To adjust the output impedance, connect a 2W, 10.0Ω load to the output to be adjusted. Set the output amplitude to 200 mA and observe the load voltage on an oscilloscope. The load voltage should have an amplitude of approximately 2V (i.e. $200 \text{ mA} \times 10\Omega = 2\text{V}$). Note the exact value. Now replace the 10.0Ω load with a 5.0Ω load. The load voltage should fall by to approximately 1V (i.e. $200 \text{ mA} \times 5\Omega = 1\text{V}$). Note the exact value. If the second voltage is not exactly one-half of the first voltage, adjust TP3 and repeat *both* measurements (10Ω and 5Ω) again. Repeat as required.

ADJUSTING MONITOR CALIBRATION

Just as the current amplitude of the main outputs can exhibit a load-voltage dependence, the voltage amplitude of the current monitors can also exhibit such a dependence if not adjusted properly.

To null out the monitor load voltage dependence, connect a 2W, 10.0Ω load to the main output to be adjusted (i.e. OUT1 or OUT2). Set the output amplitude to 5A and observe the monitor voltage (i.e. MON1 or MON2) on an oscilloscope. The monitor voltage should have an amplitude of approximately 1.54V (i.e. $200 \text{ mA} \times 7.7 \text{ V/A} = 1.54\text{V}$). Note the exact value. Now replace the 10.0Ω load with a 5.0Ω load. The monitor voltage not change, since the current amplitude has not changed. Note the exact value. If the second voltage is not exactly equal to the first voltage, adjust TP4 and repeat *both* measurements (10Ω and 5Ω) again. Repeat as required.

CALIBRATION ADJUSTMENTS - SOFTWARE PROCEDURES

ADJUSTING AMPLITUDE ACCURACY

If it is found that the output amplitude setting (as set by the front-panel controls or programming commands) does not agree exactly with measured values of amplitude (i.e., by examining the output on an oscilloscope), the amplitude calibration can be updated using software commands.

The following procedure is suggested:

- 1) Connect a precision resistive load to the output. (As an example, suppose 4.0Ω is used.)
- 2) Connect the pulse generator to a computer using the GPIB or RS232 ports.
- 3) Turn on the pulse generator, and set the time controls (frequency, delay, pulse width) to typical values.
- 4) Turn on the outputs.
- 5) Set the output amplitude to its maximum value (200 mA).
- 6) Observe the voltage across the load. (Continuing the 4.0Ω example, suppose that 0.84V is observed.) From this, calculate the measured current (0.21A).
- 7) Send one of the following commands to the instrument via the computer interface:
 - `diag:ampl:cal1 0.21A` (if channel 1 is being checked)
 - `diag:ampl:cal2 0.21A` (if channel 2 is being checked)

The internal software compares the supplied measured value to the programmed value, and adjusts the internal calibration data to null out any differences.

- 8) Observe the voltage across the load again. The amplitude setting should now agree with the measured value.

MECHANICAL INFORMATION

TOP COVER REMOVAL

The top cover of the instrument may be removed by removing the four Phillips screws on the top panel. With these four screws removed, the top panel may be slid off by pulling it towards the rear.

The instrument should not be accessed internally unless it has been turned off for ten minutes, to allow all internal capacitors to discharge. The internal capacitor bank stores a considerable amount of energy.

RACK MOUNTING

A rack mounting kit is available. The -R5 rack mount kit may be installed after first removing the one Phillips screw on the side panel adjacent to the front handle.

PROGRAMMING YOUR PULSE GENERATOR

KEY PROGRAMMING COMMANDS

The “OP1B Interface Programming Manual” describes in detail how to connect the pulse generator to your computer, and the programming commands themselves. A large number of commands are available; however, normally you will only need a few of these. Here is a basic sample sequence of commands that might be sent to the instrument after power-up, using the internal trigger source:

```
*rst                (resets the instrument)
trigger:source internal (selects internal triggering)
frequency 1000 Hz   (sets the frequency to 1000 Hz)
pulse:width1 1 us   (sets the channel 1 pulse width to 1  $\mu$ s)
pulse:width2 2 us   (sets the channel 2 pulse width to 2  $\mu$ s)
pulse:delay 10 us   (sets the inter-channel delay to 10  $\mu$ s)
output on           (turns on the output for both channels)
source:current1 100 mA (sets the channel 1 current amplitude to 0.1 Amperes)
source:current2 50 mA (sets the channel 2 current amplitude to 50 mA)
source:current:low1 0.1A (sets the channel 1 offset to 100 mA)
source:current:low2 150 mA (sets the channel 2 offset to 150 mA)
```

For triggering a single event, this sequence would be more appropriate:

```
*rst                (resets the instrument)
trigger:source hold (turns off all triggering)
pulse:width1 1 us   (sets the channel 1 pulse width to 1  $\mu$ s)
pulse:width2 3 us   (sets the channel 2 pulse width to 3  $\mu$ s)
pulse:delay 10 us   (sets the inter-channel delay to 10  $\mu$ s)
output on           (turns on the output for both channels)
source:current1 100 mA (sets the channel 1 current amplitude to 0.1 Amperes)
source:current2 50 mA (sets the channel 2 current amplitude to 50 mA)
source:current:low1 0.1A (sets the channel 1 offset to 100 mA)
source:current:low2 150 mA (sets the channel 2 offset to 150 mA)
trigger:source immediate (generates a single non-repetitive trigger event)
trigger:source hold (turns off all triggering)
output off          (turns off both outputs)
```

To control the Channel 1 output with the modulation input, but set the Channel 2 output at a constant amplitude, use this:

```
*rst                (resets the instrument)
trigger:source internal (selects internal triggering)
frequency 1000 Hz    (sets the frequency to 1000 Hz)
pulse:width1 1 us    (sets the channel 1 pulse width to 1  $\mu$ s)
pulse:width2 2 us    (sets the channel 2 pulse width to 2  $\mu$ s)
pulse:delay 10 us    (sets the inter-channel delay to 10  $\mu$ s)
output on            (turns on the output for both channels)
source:current1 ext   (the channel 1 amplitude is controlled by the AMP1 input)
source:current2 50 mA (sets the channel 2 current amplitude to 50 mA)
source:current:low1 0.1A (sets the channel 1 offset to 100 mA)
source:current:low2 150 mA (sets the channel 2 offset to 150 mA)
```

To control the Channel 1 in the normal fashion, but to use Channel 2 as an amplifier, use this:

```
*rst                (resets the instrument)
trigger:source internal (selects internal triggering)
frequency 1000 Hz    (sets the frequency to 1000 Hz)
pulse:width1 1 us    (sets the channel 1 pulse width to 1  $\mu$ s)
pulse:width2 2 us    (sets the channel 2 pulse width to 2  $\mu$ s)
pulse:delay 10 us    (sets the inter-channel delay to 10  $\mu$ s)
output on            (turns on the output for both channels)
source:current1 100 mA (sets the channel 1 current amplitude to 0.1 Amperes)
source:current2 amplify (channel 2 amplifies the signal on the AMP2 input)
source:current:low1 0.1A (sets the channel 1 offset to 100 mA)
```

These commands will satisfy 90% of your programming needs.

ALL PROGRAMMING COMMANDS

For more advanced programmers, a complete list of the available commands is given below. These commands are described in detail in the “OP1B Interface Programming Manual”. (Note: this manual also includes some commands that are not implemented in this instrument. They can be ignored.)

Note that the pulse width, amplitude, and monitor-related commands should be suffixed with the channel number, as illustrated in the previous section. If the suffix is not included, channel 1 will be assumed. The remaining commands will generate an error if a channel suffix is attached, since their effects are common to both channels.

<u>Keyword</u>	<u>Parameter</u>	<u>Notes</u>
DIAGnostic:		
:AMPLitude		
:CALibration	<numeric value>	[no query form]
LOCAL		
OUTPut:		
:[STATe]	<boolean value>	
:PROTection		
:TRIPped?		[query only]
REMOTE		
[SOURce]:		
:FREQuency		
[:CW FIXed]	<numeric value>	
[SOURce]:		
:CURRent		
[:LEVEl]		
[:IMMediate]		
[:AMPLitude]	<numeric value> EXTernal AMPLify	
:LOW	<numeric value>	
:PROTection		
:TRIPped?		[query only]
[SOURce]:		
:PULSe		
:PERiod	<numeric value>	
:WIDTh	<numeric value>	
:DCYClE	<numeric value>	
:HOLD	WIDTh DCYClE	
:DELay	<numeric value>	
:GATE		
:LEVEl	High Low	
STATUS:		
:OPERation		
:[EVENT]?		[query only, always returns "0"]
:CONDition?		[query only, always returns "0"]
:ENABle	<numeric value>	[implemented but not useful]
:QUESTionable		
:[EVENT]?		[query only, always returns "0"]
:CONDition?		[query only, always returns "0"]
:ENABle	<numeric value>	[implemented but not useful]
SYSTEM:		

:COMMunicate		
:GPIB		
:ADDRESS	<numeric value>	
:SERial		
:CONTRol		
:RTS	ON IBFull RFR	
:[RECeive]		
:BAUD	1200 2400 4800 9600	
:BITS	7 8	
:ECHO	<boolean value>	
:PARity		
:[TYPE]	EVEN ODD NONE	
:SBITS	1 2	
:ERRor		
:[NEXT]?		[query only]
:COUNT?		[query only]
:VERSion?		[query only]
TRIGger:		
:SOURce	INTernal EXTernal MANual HOLD IMMEDIATE	
*CLS		[no query form]
*ESE	<numeric value>	
*ESR?		[query only]
*IDN?		[query only]
*OPC		
*SAV	0 1 2 3	[no query form]
*RCL	0 1 2 3	[no query form]
*RST		[no query form]
*SRE	<numeric value>	
*STB?		[query only]
*TST?		[query only]
*WAI		[no query form]

PERFORMANCE CHECK SHEET