

INSTRUCTIONS

MODEL AV-155A-C

0 to 200 mA AMPLITUDE, 0 to 200 mA OFFSET,  
0 to 4V COMPLIANCE, 10 ns RISE TIME

PULSED CONSTANT CURRENT GENERATOR

SERIAL NUMBER: \_\_\_\_\_

### WARRANTY

Avtech Electrosystems Ltd. warrants products of its manufacture to be free from defects in material and workmanship under conditions of normal use. If, within one year after delivery to the original owner, and after prepaid return by the original owner, this Avtech product is found to be defective, Avtech shall at its option repair or replace said defective item. This warranty does not apply to units which have been disassembled, modified or subjected to conditions exceeding the applicable specifications or ratings. This warranty is the extent of the obligation assumed by Avtech with respect to this product and no other warranty or guarantee is either expressed or implied.

### TECHNICAL SUPPORT

Phone: 613-226-5772 or 1-800-265-6681

Fax: 613-226-2802 or 1-800-561-1970

E-mail: [info@avtechpulse.com](mailto:info@avtechpulse.com)

World Wide Web: <http://www.avtechpulse.com>

## TABLE OF CONTENTS

<b>WARRANTY</b>	<b>2</b>
<b>TECHNICAL SUPPORT</b>	<b>2</b>
<b>TABLE OF CONTENTS</b>	<b>3</b>
<b>INTRODUCTION</b>	<b>5</b>
<b>SPECIFICATIONS</b>	<b>6</b>
<b>INSTALLATION</b>	<b>7</b>
<b>VISUAL CHECK</b>	<b>7</b>
<b>PLUGGING IN THE INSTRUMENT</b>	<b>7</b>
<b>FRONT PANEL CONTROLS</b>	<b>9</b>
<b>REAR PANEL CONTROLS</b>	<b>11</b>
<b>GENERAL INFORMATION</b>	<b>12</b>
<b>BASIC PULSE CONTROL</b>	<b>12</b>
Internal Triggering	12
External Triggering, "EXT B" Mode	13
External Triggering, "EXT C" Mode ( $PW_{IN}=PW_{OUT}$ )	14
External Triggering, "EXT A" Mode (Voltage-to-Current Converter)	14
<b>TOP COVER REMOVAL</b>	<b>15</b>
<b>RACK MOUNTING</b>	<b>15</b>
<b>LOAD PROTECTION</b>	<b>16</b>
<b>PROTECTING DIODE LOADS</b>	<b>16</b>
<b>NEVER APPLY AN EXTERNAL VOLTAGE TO THE OUTPUT</b>	<b>16</b>
<b>LENZ'S LAW AND INDUCTIVE VOLTAGE SPIKES</b>	<b>16</b>
<b>ATTACHING AND DETACHING LOADS</b>	<b>17</b>
<b>OPEN AND SHORT CIRCUITS</b>	<b>17</b>
<b>CONNECTING THE LOAD FOR OPTIMUM PERFORMANCE</b>	<b>18</b>
<b>OPERATIONAL CHECK</b>	<b>19</b>
<b>CALIBRATION ADJUSTMENTS - INTERNAL TRIMPOTS</b>	<b>21</b>
<b>NULLING CONSTANT CURRENT OFFSETS</b>	<b>21</b>
<b>NULLING AMPLITUDE-DEPENDENT CURRENT OFFSETS</b>	<b>21</b>
<b>NULLING CONSTANT MONITOR OFFSETS</b>	<b>22</b>
<b>ADJUSTING OUTPUT IMPEDANCE</b>	<b>22</b>
<b>ADJUSTING MONITOR CALIBRATION</b>	<b>22</b>
<b>PERFORMANCE CHECK SHEET</b>	<b>23</b>

Manual Reference: /fileserver1/officefiles/instructword/av-155/AV-155A-C, edc.doc, created August 8, 2002

## INTRODUCTION

The Model AV-155A-C pulsed constant current generator is capable of producing pulses with amplitudes as high as 200 mA into load voltages up to 4V, with 10 ns rise and fall times. A DC offset in the range of 0 to 200 mA may be added to the pulse output. The current and voltage polarities depend on the model number:

"-P" units: 0 to +200 mA amplitude, 0 to +200 mA offset, 0 to +4V compliance

"-N" units: 0 to -200 mA amplitude, 0 to -200 mA offset, 0 to -4V compliance

"-PN" units: 0 to  $\pm 200$  mA amplitude, 0 to  $\pm 200$  mA offset, -4V to +4V compliance

The internal trigger source can be used to trigger the instrument at frequencies between 10 Hz and 10 MHz. An external TTL trigger pulse or the front-panel pushbutton can also be used to trigger the instrument.

The external trigger function offers considerable flexibility. Several modes are available:

- Voltage-to-current amplifier mode. In this case, the output signal  $I_{OUT} \approx V_{AMP} \times 0.05$ , and the output current waveform tracks the input voltage waveform. The output follows the input by a minimal fixed delay.
- $PW_{OUT} = PW_{IN}$  mode. The output pulse width tracks the input pulse width, but the amplitude is controlled by the front panel settings. The output follows the input by a minimal fixed delay. The external trigger is TTL-level.
- Normal external trigger mode. The output pulse width and amplitude are controlled by the front panel settings. The output follows the input by a programmable delay. The external trigger is TTL-level.
- In the latter two modes, the output amplitude can also be set to track a DC voltage (0 to 10V full-scale) present on the rear-panel "AMP" connector. (This optional feature is only present on units with the "-EA" model number suffix.)

The Model AV-155A-C pulse generator is a current pulser. The current amplitude is largely independent of the load voltage. For proper operation, the load voltage, where  $V_{LOAD} = |I_{LOAD} \times R_{LOAD}|$ , must not exceed 4V.

## SPECIFICATIONS

Model:	AV-155A-C	
Amplitude:	Pulse:	200 mA
	DC offset:	200 mA
	Peak:	200 mA
Pulse width:	20 ns to 20 ms	
Pulse repetition frequency (PRF):	0 to 10 MHz	
Duty cycle:	Internal trigger:	90%
(max)	External trigger:	100%
Rise time:	≤ 10 ns	
Fall time:	≤ 00 ns	
Polarity:	Units with "-P" suffix: Positive Units with "-N" suffix: negative Units with "-PN" suffix: positive and negative	
Output current regulation: (load voltage change from 0 V to 4 V)	≤ 1 %	
Load voltage range: (compliance voltage)	0 to 4 Volts	
Overshoot:	≤ 5%	
Jitter: (Ext trig in to pulse out)	< ± 100 ps ± 0.03% of sync delay	
Trigger required (Volts, Amps): (Ext trig A mode) <sup>6</sup>	$V_{IN} = \frac{I_{OUT}}{K_1}, K_1 = 0.05 \frac{\text{Amps}}{\text{Volt}}$	
Trigger required: (Ext trig B mode and trig C mode) <sup>7</sup>	TTL, PW > 50 ns	
Sync delay:	Variable 0 to 1 ms, sync out to pulse out, Advance or delay	
Sync output:	+3 Volts, 50 ns, will drive 50 Ohm loads	
Monitor output:	Back-panel SMA connector provides (to 50 Ohm) a coincident replica of the diode current.	
Connectors:	SMA 50 Ohm cable and AV-LZ6 output cable with solder terminals (or optional socket mounting <sup>8</sup> )	
	OUT	BNC
	TRIG	BNC
	MONITOR	SMA
	SYNC	BNC
Power requirement:	120/240 Volts (switchable) 50 - 60 Hz	
Dimensions: (H x W x D)	100 mm x 215 mm x 375 mm (3.9" x 8.5" x 14.8")	
Chassis material:	anodized aluminum, with blue plastic trim	
Mounting:	Any	
Temperature range:	+10° to +40°C	

## INSTALLATION

### VISUAL CHECK

After unpacking the instrument, examine to ensure that it has not been damaged in shipment. Visually inspect all connectors, knobs, and handles. Confirm that a power cord, the LZ6 flexible flat transmission line (see page 17), a 6" RG174 coaxial cable (see page 17), and this manual are with the instrument. If the instrument has been damaged, file a claim immediately with the company that transported the instrument.

### PLUGGING IN THE INSTRUMENT

Examine the rear of the instrument. There will be a male power receptacle, a fuse holder and the edge of the power selector card visible. Confirm that the power selector card is in the correct orientation.

For AC line voltages of 110-120V, the power selector card should be installed so that the "120" marking is visible from the rear of the instrument, as shown below:

For AC line voltages of 220-240V, the power selector card should be installed so that the "240" marking is visible from the rear of the instrument, as shown below:

If it is not set for the proper voltage, remove the fuse and then grasp the card with a pair of pliers and remove it. Rotate horizontally through 180 degrees. Reinstall the card and the correct fuse.

In the 120V setting, a 0.5A slow blow fuse is required. In the 240V setting, a 0.25A slow blow fuse is required.



## FRONT PANEL CONTROLS

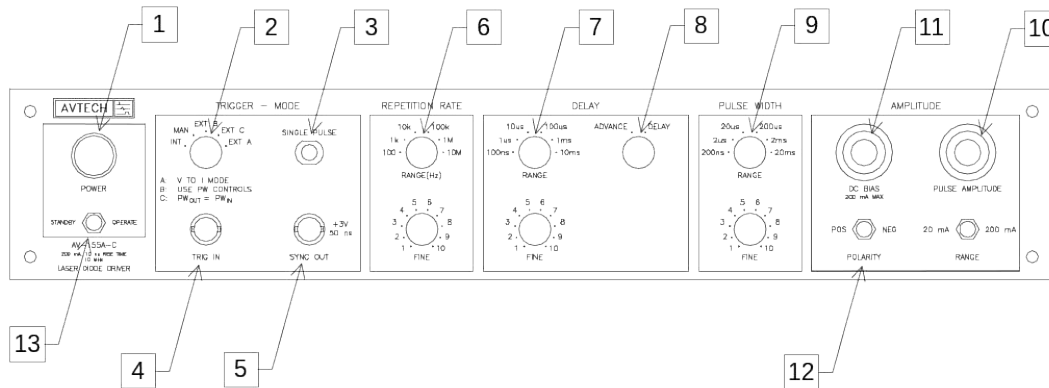

1. **POWER Switch.** The POWER push button switch applies AC prime power to the primaries of the transformer, turning the instrument on. The push button lamp (#382 type) is connected to the internal +15V DC supply.
2. **MODE Switch.** In the "INT" position the instrument is internally triggered (i.e., the pulse repetition frequency is controlled by the "REPETITION RATE" range switch and vernier dial), and the TRIG connector provides a SYNC output which allows one to trigger other instruments, such as oscilloscopes.

In the "MAN" a single pulse can be generated by pressing the "SINGLE PULSE" push button. The TRIG connector is not used in this mode.

In the "EXT A" position the instrument acts as a voltage-to-current converter, and the output current ( $I_{OUT}$ ) is related to the voltage on the TRIG connector ( $V_{TRIG}$ ) by  $I_{OUT} = V_{TRIG} \times 0.1$  Amp/Volt.

In the "EXT B" position the instrument is triggered by a TTL-level pulse on the TRIG connector. The output parameters (pulse width, delay, and amplitude) are determined by the front panel settings.

In the "EXT C" position the instrument is triggered by a TTL-level pulse on the TRIG connector. The output pulse occurs with nominally zero delay, and the output pulse width is approximately equal to the input pulse width. The amplitude is controlled by the front panel settings.

3. **SINGLE PULSE Push Button.** The "SINGLE PULSE" push button will trigger the instrument manually for one cycle of output, when the "MODE" switch is in the "MAN" position. Otherwise, the push button has no effect.
4. **TRIG Connector.** When the "MODE" switch is in the "EXT A", "EXT B", or "EXT C" position, this connector is an input. The external trigger is applied to this connector.

When operating in the "INT" mode, this connector is inactive.

The input impedance of this input is  $> 500 \Omega$ . (Depending on the length of cable attached to this input, and the source driving it, it may be desirable to add a coaxial 50 Ohm terminator to this input to provide a proper transmission line termination. The Pasternack ([www.pasternack.com](http://www.pasternack.com)) PE6008-50 BNC feed-thru 50 Ohm terminator is suggested for this purpose.)

5. SYNC Connector. A SYNC output is provided on this connector, to synchronize oscilloscopes or other measurement systems (+3 Volts, 50 ns).
6. REPETITION RATE Controls. The rotary switch marked "RANGE" selects the pulse repetition rate for the internally triggered mode. The vernier (labeled "FINE") provides continuously variable control of each range. There are five ranges and the instrument is set to the rate indicated on the front panel when the vernier is in the "MAX" position.
7. DELAY Controls. The rotary switch selects one of six ranges, and the vernier provides continuously variable control of each range. The instrument is set to the delay indicated on the front panel when the vernier is in the fully-clockwise position.
8. ADVANCE/DELAY Switch. With this switch in the DELAY position, the leading edge of the output pulse precedes the leading edge of the SYNC output. When in the ADVANCE position, the leading edge of the SYNC output precedes the leading edge of the main output.
9. PULSE WIDTH Controls. The rotary switch selects one of six ranges, and the vernier provides continuously variable control of each range. The instrument is set to the pulse width indicated on the front panel when the vernier is in the fully-clockwise position.
10. AMPLITUDE Controls. A two-position switch controls the amplitude full-scale range. The full-scale range may be set to 20 mA or 200 mA. The ten-turn amplitude vernier provides continuously variable control of the peak amplitude of the main output from 0 to the full-scale range value, as set by the range switch.
11. DC BIAS Control. This control varies the output offset, between 0 and 200 mA.
12. POLARITY. The output polarity (pulse and DC offset) is controlled by the two position polarity switch. (Present on -PN units only).
13. STANDBY/OPERATE Switch. When this switch is in the "STANDBY" position, the output is shorted to ground. It is recommended that this mode be used whenever connecting or disconnecting loads, or turning the instrument on or off.

The output operates normally in the "OPERATE" mode.

## REAR PANEL CONTROLS

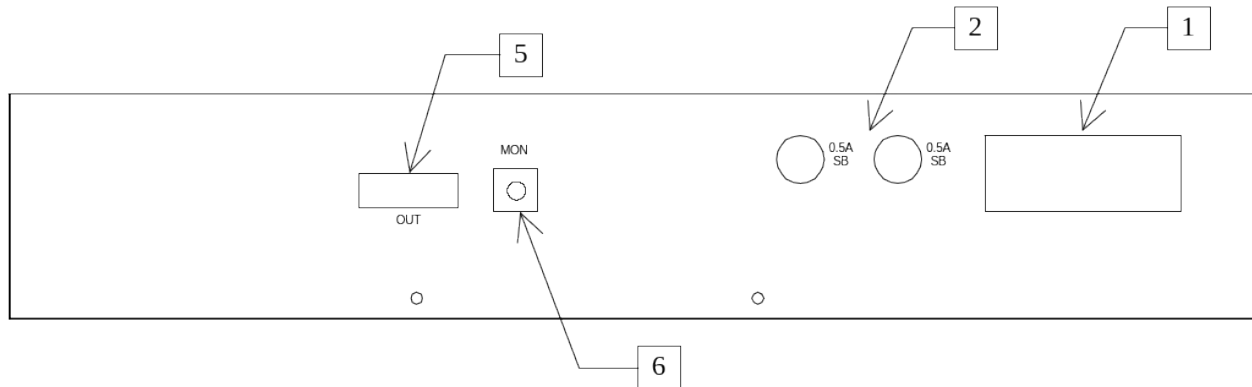

1. AC POWER INPUT. A three-pronged recessed male connector is provided on the back panel for AC power connection to the instrument. Also contained in this assembly is a slow-blow fuse and a removable card that can be removed and repositioned to switch between 120V AC in and 240V AC in.

For AC line voltages of 110-120V, the power selector card should be installed so that the "120" marking is visible from the rear of the instrument.

For AC line voltages of 220-240V, the power selector card should be installed so that the "240" marking is visible from the rear of the instrument.

If it is not set for the proper voltage, remove the fuse and then grasp the card with a pair of pliers and remove it. Rotate horizontally through 180 degrees. Reinstall the card and the correct fuse.

In the 120V setting, a 0.5A slow blow fuse is required. In the 240V setting, a 0.25A slow blow fuse is required. See the "Installation" section for more details.

2. 0.5A SB. These fuses protect the internal DC power supplies.
3. OUT. This is the main output. The LZ6 transmission line or the RG174 transmission line plugs into this socket. The upper side of the socket ("UP") is the signal line. The lower side ("DOWN") is connected to ground.
4. MON. This is a current monitor output. This output provides a voltage waveform that is proportional to the current waveform on the output. The monitor relationship is:  $V_{MON} \cong 7.7\Omega \times I_{OUT}$  (Volts, Amps) for a load of  $> 1\text{ k}\Omega$ . (The monitor output can also drive a  $50\Omega$  load, but the output voltage will be reduced by a factor of 2. This output is short-circuit protected.)

## GENERAL INFORMATION

### BASIC PULSE CONTROL

This instrument can be triggered by several sources - its own internal clock, an external TTL trigger signal, or by the front-panel "SINGLE PULSE" pushbutton. In any case, three output channels respond to the trigger: OUT, SYNC, and MON. The OUT channel is the signal that is applied to the load. Its amplitude and pulse width are variable. The SYNC pulse is a fixed-width TTL-level reference pulse used to trigger oscilloscopes or other measurement systems. When the delay is set to a positive value the SYNC pulse precedes the OUT pulse. When the delay is set to a negative value the SYNC pulse follows the OUT pulse. The MON output is a voltage waveform that is proportional to the current waveform on OUT.  $V_{MON} \cong 7.7\Omega \times I_{OUT}$ , for monitor loads of  $> 1\text{ k}\Omega$ .

The different trigger modes are detailed below. Positive outputs (i.e., generated by a "-P" or "-PN" unit) are shown in the waveform diagrams, but the principles are the same for negative instruments.

#### Internal Triggering

These pulses are illustrated below for a positive delay, and internal triggering:

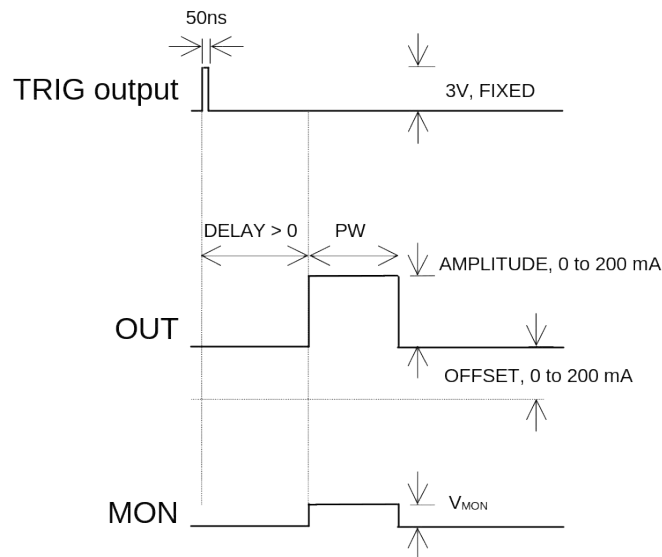

*Basic Output Pulses for Delay > 0*

The order of the output pulses is reversed for negative delays:

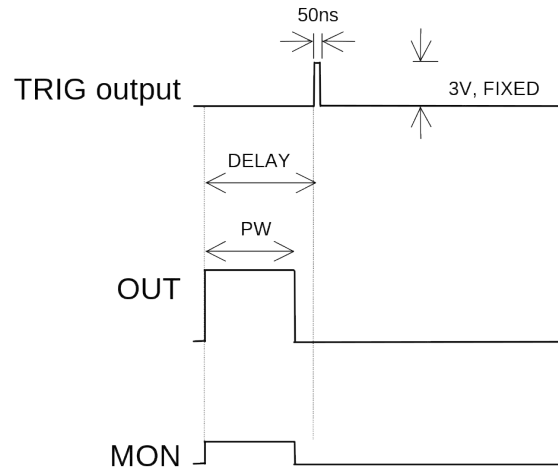

*Basic Output Pulses for Delay < 0*

The delay, pulse width, amplitude and frequency of the OUT pulse can be varied with front panel controls.

#### External Triggering, "EXT B" Mode

When the triggering is set to the "EXT B" mode, a TTL-level pulse on the TRIG input will trigger the pulse generator, as shown below:

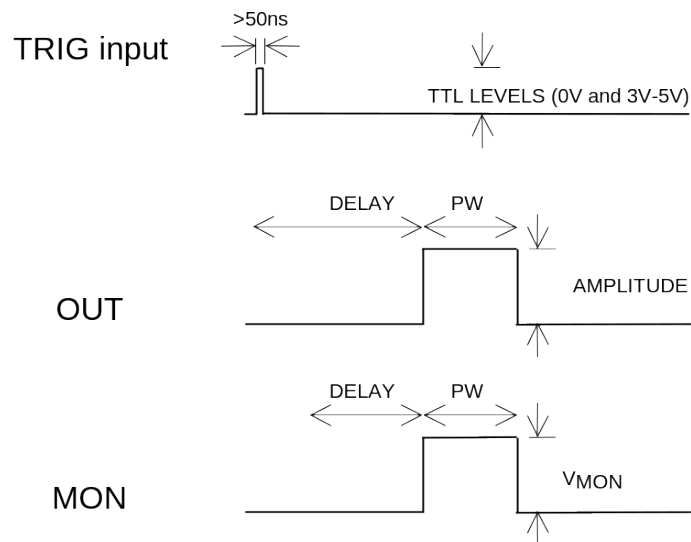

In this mode, the delay, pulse width, and amplitude of the OUT pulse can be varied with front panel controls.

External Triggering, "EXT C" Mode ( $PW_{IN}=PW_{OUT}$ )

When the triggering is set to "EXT A" mode, a TTL-level pulse on the TRIG input will trigger the pulse generator, as shown below:

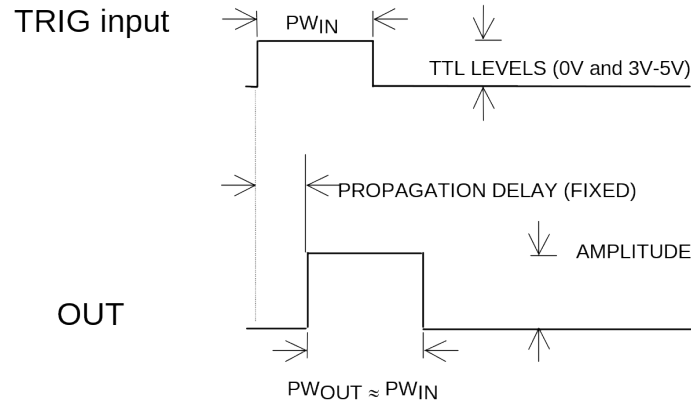

In this mode, the output pulse width is approximately equal to the pulse width of the TTL-level trigger pulse on the TRIG input. The output pulse is generated after a short propagation delay. The delay is not variable. The amplitude of the OUT pulse can be varied with front panel controls.

External Triggering, "EXT A" Mode (Voltage-to-Current Converter)

When the triggering is set to "EXT A" mode, the instrument acts as a fixed-gain voltage-to-current amplifier, and the output current is:  $I_{OUT} = 0.05 V_{AMP}$ , where  $V_{AMP}$  is the voltage waveform on the AMP connector. This is illustrated below:

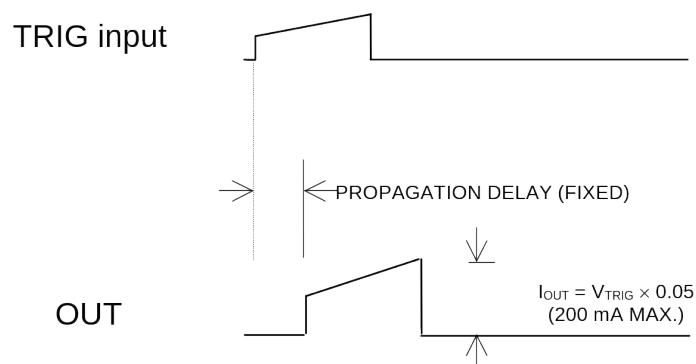

In this mode, the output pulse width and amplitude are determined by the signal on the TRIG connector. The SYNC output is not useful in this mode.

The input in this mode is always positive, regardless of whether the instrument is positive, negative, or dual-polarity.

### TOP COVER REMOVAL

The top cover of the instrument may be removed by removing the four Phillips screws on the top panel. With these four screws removed, the top panel may be slid off by pulling it towards the rear.

Always turn off the instrument before removing the cover!

### RACK MOUNTING

A rack mounting kit is available. The -R5 rack mount kit may be installed after first removing the one Phillips screw on the side panel adjacent to the front handle.

## LOAD PROTECTION

### PROTECTING DIODE LOADS

It is possible for a small offset current to be generated on the output, if the trimpots (see the “Calibration Adjustments” section) are not correctly adjusted. This can lead to the development of a negative voltage on a diode load. If the diode breakdown voltage is less than 15V, breakdown can occur. If your load is sensitive to this, the load should be protected by adding a low-capacitance shunt Schottky diode, as illustrated below:

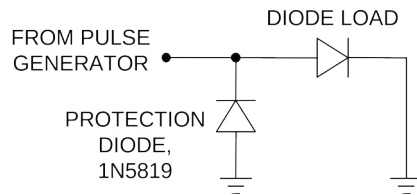

The previous diagram assumes that the diode is to be driven with a positive current. This circuit will prevent the output voltage going below approximately -0.5V.

The equivalent circuit for negative output currents is shown below:

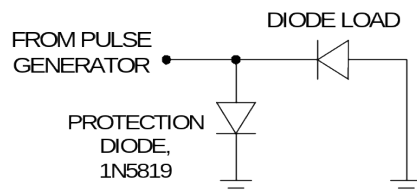

### NEVER APPLY AN EXTERNAL VOLTAGE TO THE OUTPUT

Externally generated potentials must never be applied to the output.

### LENZ'S LAW AND INDUCTIVE VOLTAGE SPIKES

This instrument is designed to pulse resistive and diode loads and will exhibit a large output spike when used to drive a load with significant inductance (as predicted by LENZ'S LAW). For this reason the load should be connected to the output using low inductance leads (as short as possible and as heavy a gauge as possible).

The voltage developed across an inductance  $L$  (in Henries), when the current is changing at a rate given by  $di_{LOAD}/dt$  (in Amps/sec), is:  $V_{SPIKE} = L \frac{di_{LOAD}}{dt}$ .



## ATTACHING AND DETACHING LOADS

To avoid damaging the loads connected to main outputs, the loads should only be connected to or removed from the instrument when:

- the instrument is off
- the instrument is on, but the "STANDBY/OPERATE" switch is in the STANDBY position.

Do not connect loads when the instrument is on and the outputs are turned on. This can cause sparking.

## CHANGING PARAMETERS WHEN A LOAD IS ATTACHED

If your load is easily damaged, reduce the amplitude and offset settings to zero, and switch the instrument to STANDBY mode before changing the timing parameters, especially if you need to change a timing range setting. This protects the loads from possible short transient effects.

## OPEN AND SHORT CIRCUITS

The AV-155A-C will operate properly into a short circuit to ground. Operation into an open circuit will not damage the instrument in any way.

## CONNECTING THE LOAD FOR OPTIMUM PERFORMANCE

This instrument is supplied with two types of output cables, which can be plugged in the the OUT socket on the rear panel:

- The LZ6 flexible flat transmission line, which has a  $6\Omega$  characteristic impedance ( $Z_0$ ).
- A 6" RG174 coaxial transmission line, which has a  $50\Omega$  characteristic impedance ( $Z_0$ ).

For both cables, the end that plugs into the rear panel is marked with an "UP" side and a "DOWN" side. (The UP side is the signal output, and the DOWN side is ground.)

The LZ6 transmission line is terminated with a small circuit board, as shown below:

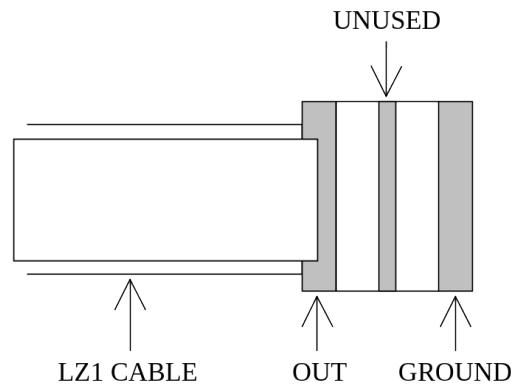

To obtain the very best waveform, it is important that the characteristic impedance of the transmission line used to connect the load to the pulser be well matched to the load impedance. This will minimize transmission line reflections.

Thus, when connecting to a low-impedance load, like a laser diode, the LZ6 line will provide the best performance. However, the LZ6 line may be physically awkward to use. If increased rise time or waveform ringing can be tolerated, the 6" length of RG-174 cable may be used instead.

For more information regarding connection methods, see "Technical Brief No. 1 - How to Connect Loads to your Pulsed Constant Current Generator for Optimum Performance", online at <http://www.avtechpulse.com/appnote>.

## OPERATIONAL CHECK

This section describes a sequence to confirm the basic operation of the instrument. It should be performed after receiving the instrument. It is a useful learning exercise as well.

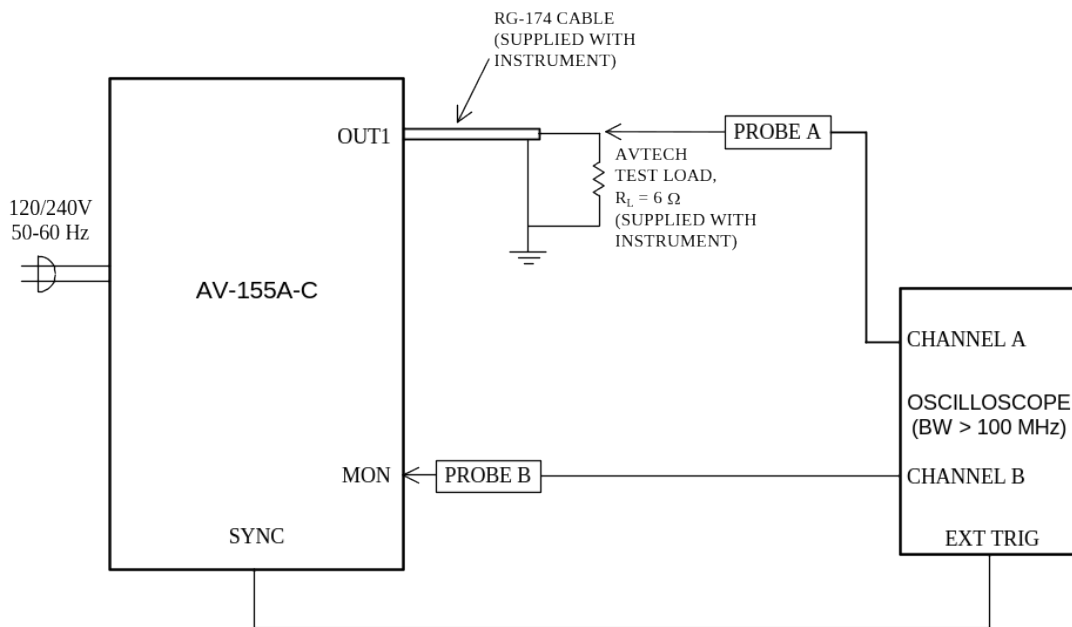

*Basic Test Arrangement*

- 1) Insert the card-end of the supplied RG-174 cable into the rear-panel "OUT" slot connector of the AV-155A-C. Attached the supplied connectorized 6 Ohm test load to the other end of the RG-174 cable.
- 2) Connect a cable from the SYNC connector to the TRIG input of an oscilloscope. Set the oscilloscope to trigger externally.
- 3) Connect one oscilloscope probe (channel A) to the signal side of the test load. Connect the other probe to the MON output (on the rear panel). On the oscilloscope, set the channel A vertical scale to 1 V/div, the channel B vertical scale to 1 V/div, and the horizontal scale to 200 ns/div.
- 4) Turn on the AV-155A-C.
- 5) To set the AV-155A-C to trigger from the internal clock at a PRF of 10 kHz, set the repetition frequency range switch to 10 kHz, and rotate the FINE vernier control fully clockwise.

- 6) To set the OUT pulse width to 500 ns, set the pulse width range switch to 1 us, and rotate the FINE vernier control to halfway between minimum and maximum.
- 7) At this point, nothing should appear on the oscilloscope.
- 8) Switch the STANDBY/OPERATE switch to "OPERATE".
- 9) Switch the amplitude range switch to "200 mA". Rotate the amplitude vernier to its maximum setting.
- 10) Set the offset control fully counter-clockwise.
- 11) On the oscilloscope, you should see pulses with 1.2V of amplitude (i.e.,  $200 \text{ mA} \times 6\Omega$ ), approximately 500 ns pulse width, and 10 kHz repetition rate.
- 12) This completes the operational check.

If additional assistance is required:

Tel: (613) 226-5772,  
Fax: (613) 226-2802  
Email: [info@avtechpulse.com](mailto:info@avtechpulse.com)

## CALIBRATION ADJUSTMENTS - INTERNAL TRIMPOTS

The output module has five trimming potentiometers ("trimpots") that can be used to adjust the performance of the output. These trimpots are preset at the factory and should not normally require adjusting after delivery. These controls can be accessed by removing the top panel of the instrument, and by locating the output-stage module. It is near the rear of the instrument.

The locations of the trimpots (designated TP1-TP5) are shown below. All should be accessible through any heatsinking.

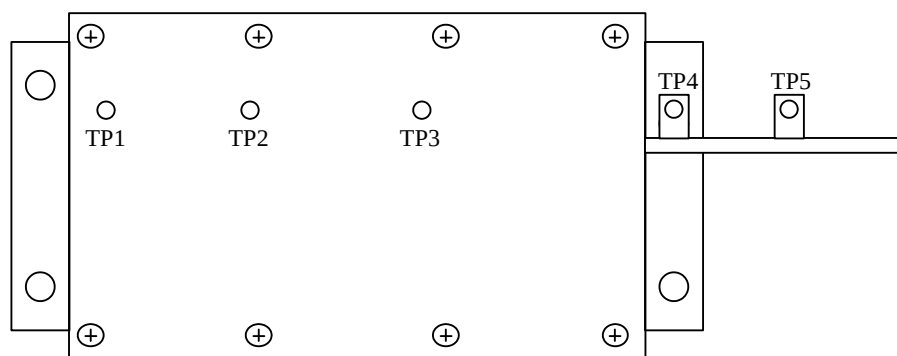

*Location of Trimpots*

These trimpots can be used to adjust or calibrate the followings properties:

- Current offsets on the main outputs.
- Voltage offsets on the monitor outputs.
- Monitor calibration.
- Output impedance.

### NULLING CONSTANT CURRENT OFFSETS

If a small constant current offset is observed on one of the main outputs, TP2 can be rotated to reduce it to zero.

### NULLING AMPLITUDE-DEPENDENT CURRENT OFFSETS

If a small amplitude-dependent current offset is observed on one of the main outputs, TP1 can be rotated to null it out. Rotate TP1 while adjusting the output amplitude from the front panel, until the offset does not vary with amplitude.

### NULLING CONSTANT MONITOR OFFSETS

If a small constant voltage offset is observed on one of the monitor outputs, TP5 can be rotated to reduce it to zero.

### ADJUSTING OUTPUT IMPEDANCE

Ideally, the outputs of the pulsed current sources should be independent of the output voltages, within the 0 to  $\pm 4\text{V}$  compliance voltage range. This condition represents infinite output impedance. If a load voltage/output current dependence is present, the output impedance needs to be adjusted.

To adjust the output impedance, connect a  $6\Omega$  load to the output to be adjusted. Set the output amplitude to 200 mA and observe the load voltage on an oscilloscope. The load voltage should have an amplitude of approximately 1.2V (i.e.  $200\text{ mA} \times 6\Omega = 1.2\text{V}$ ). Note the exact value. Now replace the  $6\Omega$  load with a  $3\Omega$  load. The load voltage should fall by to approximately 0.6V (i.e.  $200\text{ mA} \times 3\Omega = 0.6\text{V}$ ). Note the exact value. If the second voltage is not exactly one-half of the first voltage, adjust TP3 and repeat *both* measurements ( $6\Omega$  and  $3\Omega$ ) again. Repeat as required.

### ADJUSTING MONITOR CALIBRATION

Just as the current amplitude of the main outputs can exhibit a load-voltage dependence, the voltage amplitude of the current monitors can also exhibit such a dependence if not adjusted properly.

To null out the monitor load voltage dependence, connect a  $6\Omega$  load to the main output. Set the output amplitude to 200 mA and observe the monitor voltage on an oscilloscope. The monitor voltage should have an amplitude of approximately 1.54V. Note the exact value. Now replace the  $6\Omega$  load with a  $3\Omega$  load. The monitor voltage should not change, since the current amplitude has not changed. Note the exact value. If the second voltage is not exactly equal to the first voltage, adjust TP4 and repeat *both* measurements ( $6\Omega$  and  $3\Omega$ ) again. Repeat as required.

PERFORMANCE CHECK SHEET