

INSTRUCTIONS

MODEL AV-155A-C-EA-EW-EO-LZ3-S5-M-OP1B

0 to -200 mA AMPLITUDE, 0 to -200 mA OFFSET,
0 to -4V COMPLIANCE, 10 ns RISE TIME

PULSED CONSTANT CURRENT GENERATOR

WITH IEEE 488.2 AND RS-232 CONTROL

SERIAL NUMBER: _____

WARRANTY

Avtech Electrosystems Ltd. warrants products of its manufacture to be free from defects in material and workmanship under conditions of normal use. If, within one year after delivery to the original owner, and after prepaid return by the original owner, this Avtech product is found to be defective, Avtech shall at its option repair or replace said defective item. This warranty does not apply to units which have been disassembled, modified or subjected to conditions exceeding the applicable specifications or ratings. This warranty is the extent of the obligation assumed by Avtech with respect to this product and no other warranty or guarantee is either expressed or implied.

TECHNICAL SUPPORT

Phone: 613-226-5772 or 1-800-265-6681

Fax: 613-226-2802 or 1-800-561-1970

E-mail: info@avtechpulse.com

World Wide Web: <http://www.avtechpulse.com>

TABLE OF CONTENTS

WARRANTY	
TECHNICAL SUPPORT	
TABLE OF CONTENTS	
INTRODUCTION	
SPECIFICATIONS	
INSTALLATION	
VISUAL CHECK	
PLUGGING IN THE INSTRUMENT	
FRONT PANEL CONTROLS	
REAR PANEL CONTROLS	
GENERAL INFORMATION	
BASIC PULSE CONTROL	
Internal Triggering	
External Triggering, with Normal PW and Amplitude Modes	
External Triggering, with $PW_{IN}=PW_{OUT}$ mode and Normal Amplitude Mode	
External Amplitude Mode	
Amplifier Mode	
TRIGGER SOURCES	
GATING MODES	
TOP COVER REMOVAL	
RACK MOUNTING	
LOAD PROTECTION	
PROTECTING DIODE LOADS	
LENZ'S LAW AND INDUCTIVE VOLTAGE SPIKES	
OUTPUT ON/OFF	
ATTACHING AND DETACHING LOADS	
OPEN AND SHORT CIRCUITS	
CONNECTING THE LOAD FOR OPTIMUM PERFORMANCE	
OPERATIONAL CHECK	
CALIBRATION ADJUSTMENTS - INTERNAL TRIMPOTS	
NULLING CONSTANT CURRENT OFFSETS	
NULLING AMPLITUDE-DEPENDENT CURRENT OFFSETS	
NULLING CONSTANT MONITOR OFFSETS	
ADJUSTING OUTPUT IMPEDANCE	
ADJUSTING MONITOR CALIBRATION	

CALIBRATION ADJUSTMENTS - SOFTWARE PROCEDURES_____

ADJUSTING AMPLITUDE ACCURACY_____

PROGRAMMING YOUR PULSE GENERATOR_____

KEY PROGRAMMING COMMANDS_____

ALL PROGRAMMING COMMANDS_____

PERFORMANCE CHECK SHEET_____

INTRODUCTION

The Model AV-155A-C-EA-EW-EO-LZ3-S5-M-OP1B pulsed constant current generator is capable of producing pulses with amplitudes as high as -200 mA into load voltages up to -4V, with 10 ns rise and fall times. A DC offset in the range of 0 to -200 mA may be added to the pulse output. The internal trigger source can be used to trigger the instrument at frequencies between 0.1 Hz and 10 MHz. An external TTL trigger pulse, a front-panel pushbutton, and a computer can also be used to trigger the instrument.

The external trigger function offers considerable flexibility. Several modes are available:

- The output is an amplified version of the external trigger signal. In this case, the output signal $I_{OUT} \approx V_{TRIG} \times -100 \text{ mA/V}$, and the output amplitude pulse width tracks the input pulse width. The output follows the input by a minimal fixed delay.
- The output pulse width tracks the input pulse width, but the amplitude is controlled by the front panel settings (or by programming commands). The output follows the input by a minimal fixed delay. The external trigger is TTL-level.
- The output pulse width and amplitude are controlled by the front panel settings (or by programming commands). The output follows the input by a programmable delay. The external trigger is TTL-level. (This is the “-EW” option.)
 - In the latter two modes, the output amplitude can also be set to track a DC voltage (0 to 10V full-scale) present on the rear-panel “EA” connector. (This is the “-EA” option.) Similarly, the output offset can be set to track a DC voltage (0 to 10V full-scale) present on the rear-panel “EO” connector. (This is the “-EO” option.)

The Model AV-155A-C-EA-EW-EO-LZ3-S5-M-OP1B pulse generator is a current pulser. The current amplitude is largely independent of the load voltage. For proper operation, the load voltage ($V_{LOAD} = I_{LOAD} \times R_{LOAD}$) must lie in the range of 0 to -4V.

The AV-155A-C-EA-EW-EO-LZ3-S5-M-OP1B features front panel keyboard and adjust knob control of the output pulse parameters along with a four line by 40 character backlit LCD display of the output amplitude, pulse width, pulse repetition frequency, and delay. The instrument includes memory to store up to four complete instrument setups. The operator may use the front panel or the computer interface to store a complete “snapshot” of all key instrument settings, and recall this setup at a later time.

SPECIFICATIONS

Model:	AV-155A-C-EA-EW-EO-LZ3-S5-M-OP1B
Amplitude:	Pulse: 0 to -200 mA, DC Offset: 0 to -200 mA, Peak: -400 mA, for load voltages of 0 to -4 Volts
Pulse width:	20 ns to 2 μ s
Rise time:	\leq 10 ns
Fall time:	\leq 10 ns
PRF:	internal trigger: 0.1 Hz to 10 MHz external or pushbutton trigger: 0 to 10 MHz
Max. duty cycle:	Internal trigger: 90% External trigger: 100%
Output current regulation:	\leq 1% for load change from -4V to 0V
Trigger required: (external trigger mode)	Internal PW Mode: +5 Volt, 50 ns or wider (TTL)
Monitor output:	Provides an attenuated coincident replica of the main output current pulse. $V_{MON} = I_{LOAD} \times 10 \Omega$
Sync output:	+ 5 Volts, 50 ns wide, will drive 50 Ohm loads
Connectors:	Out: LZ3 socket, Gate, Trig, Sync, Monitor: BNC
Power, AC:	120/240 Volts (switchable) 50 - 60 Hz
Dimensions:	3.9" x 17" x 14.8"
Chassis material:	anodized aluminum, with blue plastic trim
Mounting:	Any
Temperature range:	+ 10° to + 40° C

INSTALLATION

VISUAL CHECK

After unpacking the instrument, examine to ensure that it has not been damaged in shipment. Visually inspect all connectors, knobs, liquid crystal displays (LCDs), and the handles. Confirm that a power cord and two instrumentation manuals (this manual and the "OP1B Interface Programming Manual") are with the instrument. If the instrument has been damaged, file a claim immediately with the company that transported the instrument.

PLUGGING IN THE INSTRUMENT

Examine the rear of the instrument. There will be a male power receptacle, a fuse holder and the edge of the power selector card visible. Confirm that the power selector is in the correct orientation - it should be marked either 120 or 240, indicating whether it expects 120V AC or 240V AC. If it is not set for the proper voltage, remove the fuse and then grasp the card with a pair of pliers and remove it. Rotate horizontally through 180 degrees. Reinstall the card and the correct fuse. In the 120V setting, a 1A slow blow fuse is required. In the 240V setting, a 1/2A slow blow fuse is required.

FRONT PANEL CONTROLS

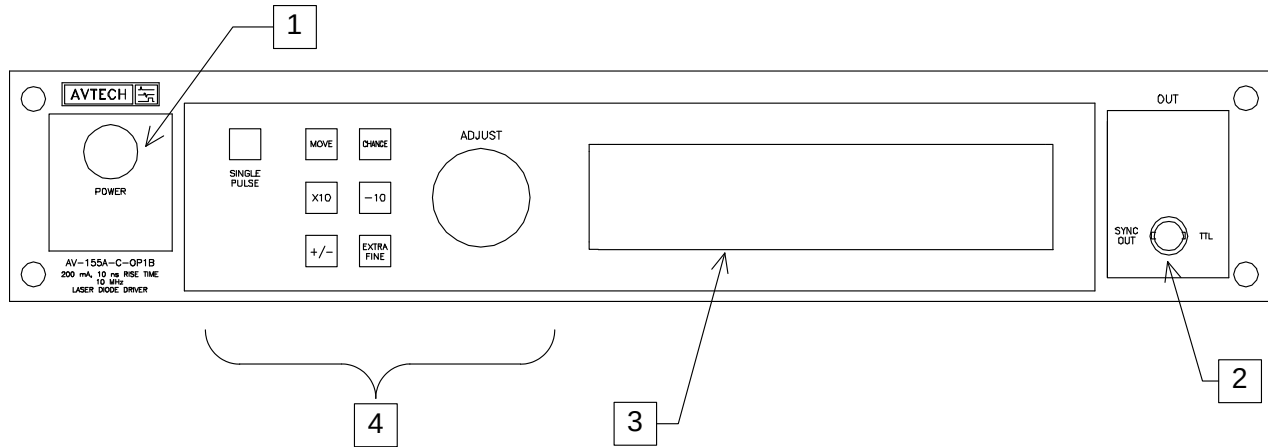

1. **POWER Switch.** The POWER push button switch applies AC prime power to the primaries of the transformer, turning the instrument on. The push button lamp (#382 type) is connected to the +15V DC supply.
2. **SYNC OUT.** This connector supplies a SYNC output that can be used to trigger other equipment, particularly oscilloscopes. The sync output has an approximate amplitude of +3 Volts to $R_L > 1\text{ k}\Omega$ with a pulse width of approximately 50 ns.
3. **LIQUID CRYSTAL DISPLAY (LCD).** This LCD is used in conjunction with the keypad to change the instrument settings. Normally, the main menu is displayed, which lists the key adjustable parameters and their current values. The "OP1B Interface Programming Manual" describes the menus and submenus in detail.
4. **KEYPAD.**

Control Name	Function
MOVE	This moves the arrow pointer on the display.
CHANGE	This is used to enter the submenu, or to select the operating mode, pointed to by the arrow pointer.
×10	If one of the adjustable numeric parameters is displayed, this increases the setting by a factor of ten.
÷10	If one of the adjustable numeric parameters is displayed, this decreases the setting by a factor of ten.
+/-	If one of the adjustable numeric parameters is displayed, and this parameter can be both positive or negative, this changes the sign of the parameter.
EXTRA FINE	This changes the step size of the ADJUST knob. In the extra-fine mode, the step size is twenty times finer than in the normal mode. This button switches between the two step sizes.
ADJUST	This large knob adjusts the value of any displayed numeric adjustable values, such as frequency, pulse width, etc. The adjust step size is set by the "EXTRA FINE" button.

	<p>When the main menu is displayed, this knob can be used to move the arrow pointer.</p>
--	--

REAR PANEL CONTROLS

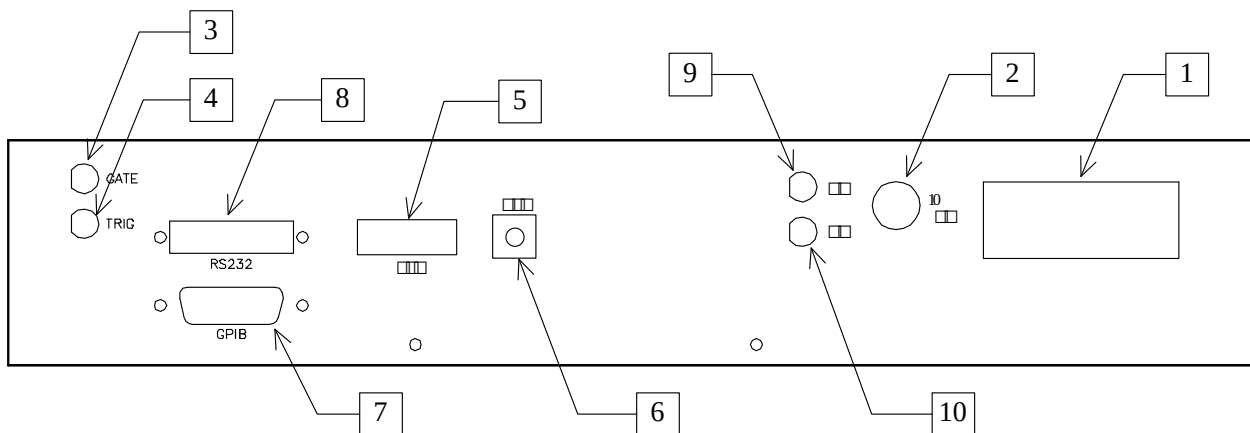

1. **AC POWER INPUT.** A three-pronged recessed male connector is provided on the back panel for AC power connection to the instrument. Also contained in this assembly is a 2.0A slow blow fuse and a removable card that can be removed and repositioned to switch between 120V AC in and 240V AC in.
2. **1.0A SB.** This fuse protects the internal +15V DC power supply.
3. **GATE.** This TTL-level (0 and +5V) logic input can be used to gate the triggering of the instrument. This input can be either active high or active low, depending on the front panel settings or programming commands. (The instrument triggers normally when this input is unconnected).
4. **TRIG.** This input can be used to trigger the instrument, if the instrument is set to triggering externally. The instrument triggers on the rising edge of this input. (The output pulse width can be set to track the pulse width on this input. This is the “EW” option.)
5. **OUT.** This is the main output. The LZ3 transmission line or the RG174 transmission line plugs into this socket. The upper side of the socket (“UP”) is the signal line. The lower side (“DOWN”) is connected to ground.
6. **MON.** This is a current monitor output. This output provides a voltage waveform that is proportional to the current waveform on the output. The monitor relationship is: $V_{MON} = 10\Omega \times I_{OUT}$, for a load of $> 10\text{ k}\Omega$. (The monitor output can also drive a 50Ω load, but the output voltage will be reduced by a factor of 2. This output is short-circuit protected.)
7. **GPIB Connector.** A standard GPIB cable can be attached to this connector to allow the instrument to be computer-controlled. See the “OP1B Interface Programming Manual” for more details on GPIB control.
8. **RS-232 Connector.** A standard serial cable with a 25-pin male connector can be attached to this connector to allow the instrument to be computer-controlled. See the “OP1B Interface Programming Manual” for more details on RS-232 control.

9. EA Connector. The amplitude can be set to track a DC voltage present on this connector. (In this mode, the front-panel display will read "AMP:EXT".) Zero volts corresponds to zero output amplitude; +10V corresponds to maximum amplitude, approximately.

10. EO Connector. The output offset can be set to track a DC voltage present on this connector. (In this mode, the front-panel display will read "OS:EXT".) Zero volts corresponds to zero output offset; +10V corresponds to maximum offset, approximately.

GENERAL INFORMATION

BASIC PULSE CONTROL

This instrument can be triggered by several sources - its own internal clock, an external TTL trigger signal, the front-panel "SINGLE PULSE" pushbutton, or by a computer-generated command. In any case, three output channels respond to the trigger: OUT, SYNC, and MON. The OUT channel is the signal that is applied to the load. Its amplitude and pulse width are variable. The SYNC pulse is a fixed-width TTL-level reference pulse used to trigger oscilloscopes or other measurement systems. When the delay is set to a positive value the SYNC pulse precedes the OUT pulse. When the delay is set to a negative value the SYNC pulse follows the OUT pulse. The MON output is a voltage waveform that is proportional to the current waveform on OUT: $V_{MON} = 10\Omega \times I_{OUT}$ for monitor loads of $> 10\text{ k}\Omega$.

The different trigger modes are detailed below:

Internal Triggering

These pulses are illustrated below for a positive delay, and internal triggering:

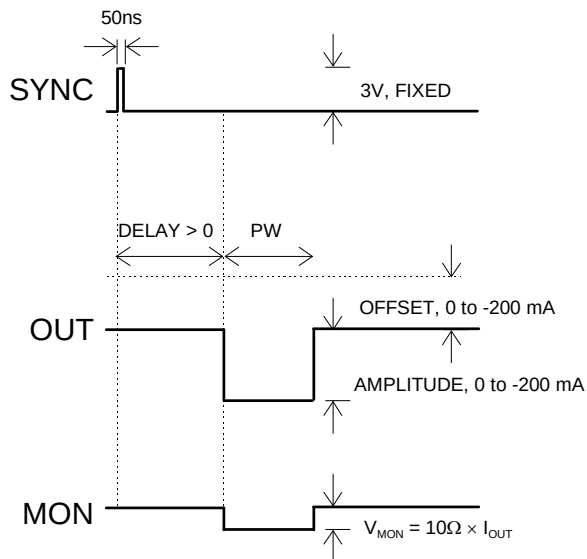

Basic Output Pulses for Delay > 0

The order of the output pulses is reversed for negative delays:

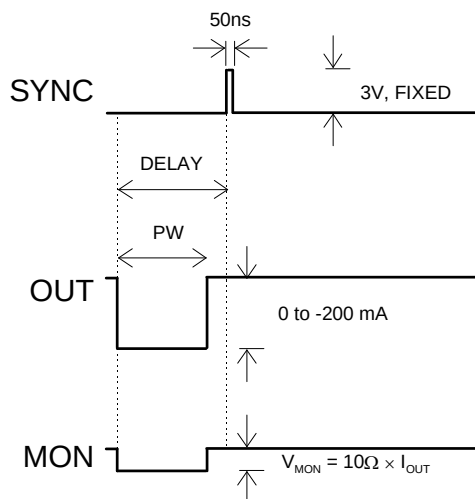

Basic Output Pulses for Delay < 0

The delay, pulse width, amplitude and frequency of the OUT pulse can be varied with front panel controls or via the GPIB or RS-232 computer interfaces in this mode.

External Triggering, with Normal PW and Amplitude Modes

When the triggering is set to external mode, and the pulse width and amplitude modes are set to “normal” (i.e., the front-panel display reads “EXT TRIG”, “PW:??ns”, and “AMP:??mA”, where “??” means a number), a TTL-level pulse on the TRIG input will trigger the pulse generator, as shown below:

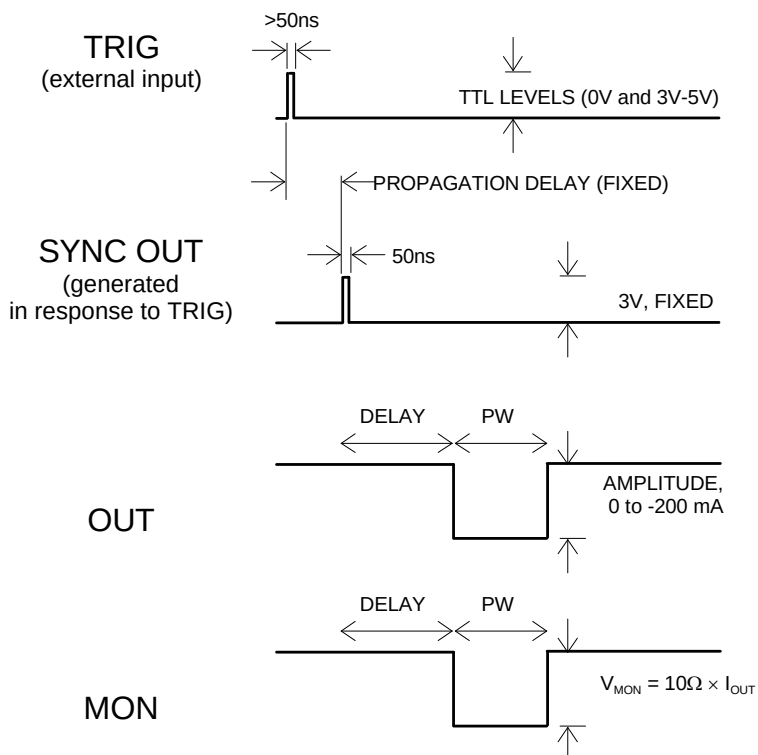

In this mode, the delay, pulse width, and amplitude of the OUT pulse can be varied with front panel controls or via the GPIB or RS-232 computer interfaces.

External Triggering, with $PW_{IN}=PW_{OUT}$ mode and Normal Amplitude Mode

When the triggering is set to external mode, the amplitude mode is set to “normal”, and the “ $PW_{IN}=PW_{OUT}$ ” pulse width mode is used, (i.e., the front-panel display reads “EXT TRIG”, “PW IN=OUT”, and “AMP:??mA”, where “??” is a number) a TTL-level pulse on the TRIG input will trigger the pulse generator, as shown below:

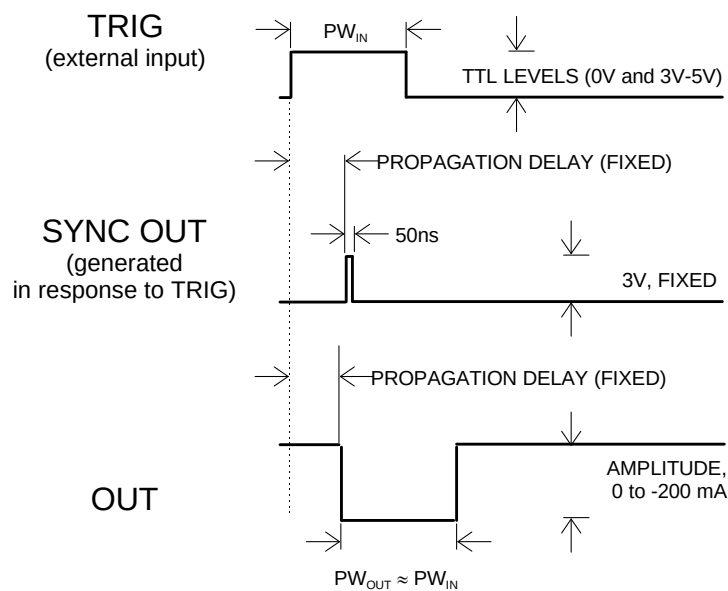

In this mode, the output pulse width is approximately equal to the pulse width of the TTL-level trigger pulse on the TRIG input. The output pulse is generated after a short propagation delay. The delay is not variable. The amplitude of the OUT pulse can be varied with front panel controls or via the GPIB or RS-232 computer interfaces.

External Amplitude Mode

In any of the previously mentioned modes, the amplitude can be set to track a 0 to +10V DC voltage present on the EA connector. (In this mode, the front-panel display reads “AMP:EXT”.) This is illustrated below:

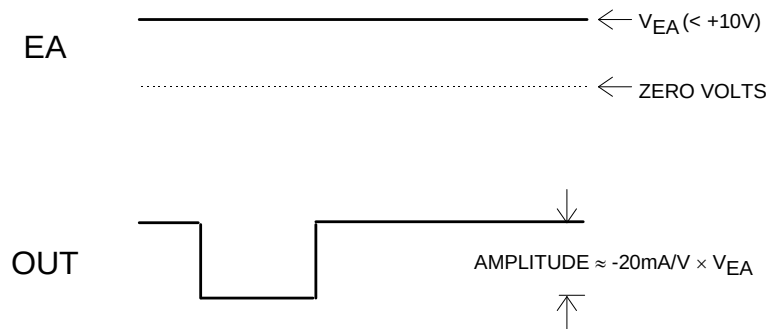

The offset can be similarly controlled via the EO connector. (In this mode, the front-panel display reads “OS:EXT”.)

The pulse width, delay, frequency, and triggering are controlled as described above.

Amplifier Mode

When the triggering is set to amplifier mode (i.e., the front-panel display reads “EXT AMPLIFY”), the instrument acts as a fixed-gain amplifier, and the output current is: $I_{OUT} = V_{TRIG} \times -100 \text{ mA/V}$, where V_{TRIG} is the voltage waveform on the TRIG connector. This is illustrated below:

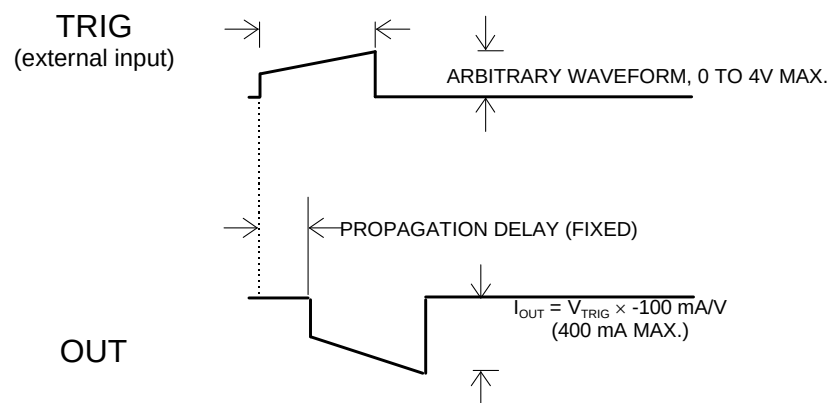

In this mode, the output pulse width and amplitude are determined by the signal on the TRIG connector. Note that a SYNC pulse is only generated if the TRIG input exceeds approximately 2V (i.e. a TTL-level logic high).

TRIGGER SOURCES

This instrument has several possible trigger sources:

- Internal Trigger: the instrument controls the trigger frequency, and generates the clock internally.

- External Trigger: the instrument is triggered by an external TTL-level signal on the back-panel TRIG connector. As noted in the previous section, the exact function of this trigger is determined by the amplitude and pulse width mode settings.
- External Amplifier Mode Trigger: the instrument is triggered by an analog signal on the back-panel TRIG connector.
- Manual Trigger: the instrument is triggered by the front-panel “SINGLE PULSE” pushbutton.
 - Hold Trigger: the instrument is set to not trigger at all.

These modes can be selected using the front panel trigger menu, or by using the appropriate programming commands. (See the “OP1B Interface Programming Manual” for more details.)

When being controlled by a computer, there is a additional trigger mode:

- Immediate Trigger: generates a single trigger event. This is the computer-control equivalent of pressing the front-panel “SINGLE PULSE” pushbutton.

GATING MODES

Triggering can be suppressed by a TTL-level signal on the rear-panel GATE connector. The instrument can be set to stop triggering when this input high or low, using the front-panel gate menu or the appropriate programming commands.

This gate signal acts synchronously - i.e., when gated, the output will complete the full pulse width if the output is high, and then stop triggering. No pulses are truncated in this mode.

TOP COVER REMOVAL

The top cover of the instrument may be removed by removing the four Phillips screws on the top panel. With these four screws removed, the top panel may be slid off by pulling it towards the rear.

Always turn off the instrument before removing the cover!

RACK MOUNTING

A rack mounting kit is available. The -R5 rack mount kit may be installed after first removing the one Phillips screw on the side panel adjacent to the front handle.

LOAD PROTECTION

PROTECTING DIODE LOADS

It is possible for a small positive offset current (on the order of +1mA) to be generated on the output, if the trimpots (see the “Calibration Adjustments” section) are not correctly adjusted. This can lead to the development of a negative voltage on a diode load. If the diode breakdown voltage is less than 15V, breakdown can occur. If your load is sensitive to this, the load should be protected by adding a low capacitance shunt diode, as illustrated below:

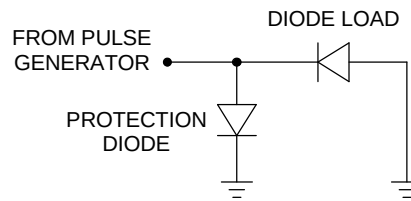

This will prevent the output voltage from rising above approximately 0.7V.

LENZ'S LAW AND INDUCTIVE VOLTAGE SPIKES

This instrument is designed to pulse resistive and diode loads and will exhibit a large output spike when used to drive a load with significant inductance (as predicted by LENZ'S LAW). For this reason the load should be connected to the output using low inductance leads (as short as possible and as heavy a gauge as possible).

The voltage developed across an inductance L (in Henries), when the current is changing at a rate given by di_{LOAD}/dt (in Amps/sec), is: $V_{SPIKE} = L \frac{di_{LOAD}}{dt}$.

OUTPUT ON/OFF

The main outputs may be switched on and off using the front-panel controls or via programming commands. When the output is set “OFF”, the main outputs are short-circuited to ground with a relay, and the trigger source is removed from the output stage.

ATTACHING AND DETACHING LOADS

To avoid damaging the loads connected to main outputs, the loads should only be connected to or removed from the instrument when:

- the instrument is off
 - the instrument is on, but the outputs are turned off (i.e. the LCD display reads “OUTPUT OFF”)

Do not connect loads when the instrument is on and the outputs are turned on. This can cause mild sparking.

CHANGING PARAMETERS WHEN A LOAD IS ATTACHED

If your load is easily damaged, the outputs should be turned off when changing the trigger source, frequency, pulse width, or other pulse parameters. This protects the loads from possible short transient effects.

OPEN AND SHORT CIRCUITS

The AV-155A-C-EA-EW-EO-LZ3-S5-M-OP1B will operate properly into a short circuit to ground. Operation into an open circuit will not damage the instrument in any way.

CONNECTING THE LOAD FOR OPTIMUM PERFORMANCE

This instrument is supplied with two types of output cables, which can be plugged in the the OUT socket on the rear panel:

- The LZ3 flexible flat transmission line, which has a 3Ω characteristic impedance (Z_0), and is terminated with a S5 laser-diode socket. This socket is specifically designed to accept an SDL G1 package. No additional termination is required when this socket is used.
- A 6" RG174 coaxial transmission line, which has a 50Ω characteristic impedance (Z_0). For the best performance, the cable should be terminated with an impedance as close to 50Ω as is feasible.

For both cables, the end that plugs into the rear panel is marked with an "UP" side and a "DOWN" side. (The UP side is the signal output, and the DOWN side is ground.)

A G1-package diode load can be inserted into the end of the LZ3 line. The diode is inserted from the signal-side of the small circuit board, not the ground-plane side. The connection scheme is illustrated below:

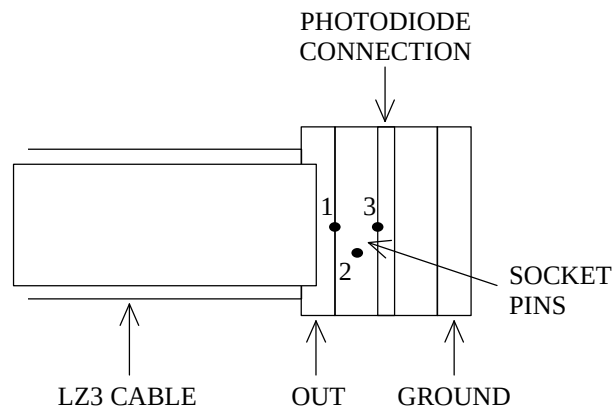

The bottom view of a G1 package, with the corresponding pin numbers, is shown below:

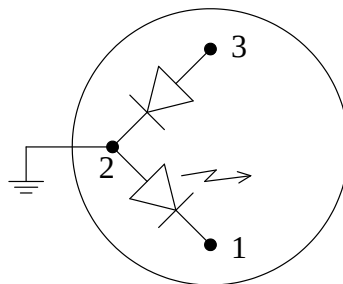

BOTTOM VIEW OF G1 PACKAGE

OPERATIONAL CHECK

This section describes a sequence to confirm the basic operation of the instrument. It should be performed after receiving the instrument. It is a useful learning exercise as well.

Before proceeding with this procedure, finish reading this instruction manual thoroughly. Then read the “Local Control” section of the “OP1B Interface Programming Manual” thoroughly. The “Local Control” section describes the front panel controls used in this operational check - in particular, the MOVE, CHANGE, and ADJUST controls.

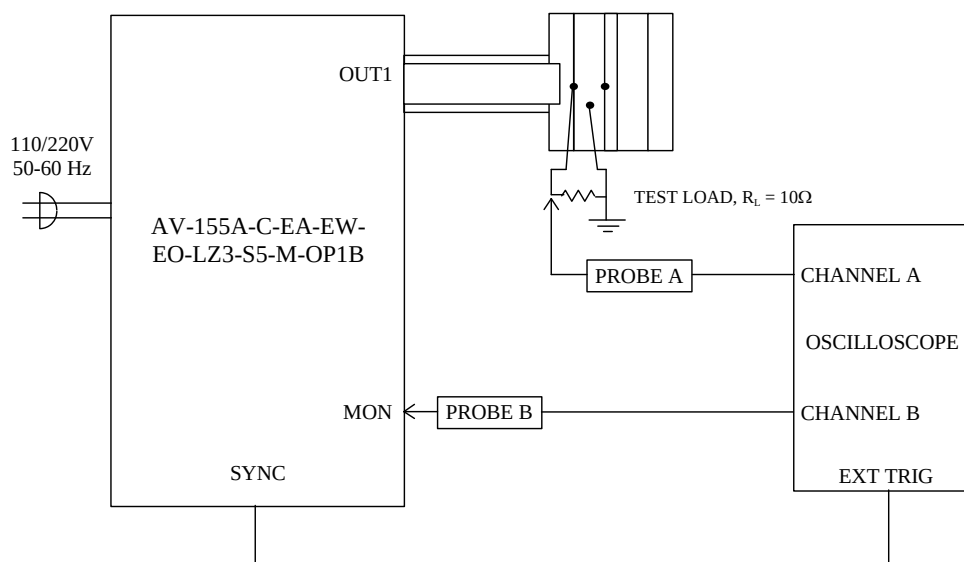

Basic Test Arrangement

- 1 Insert a 10Ω test load between pin 1 (signal out) and pin 2 (ground) of the socket on the LZ3 circuit board.
- 2 Connect a cable from the SYNC OUT connector to the TRIG input of an oscilloscope. Set the oscilloscope to trigger externally.
- 3 Connect one oscilloscope probe (channel A) to pin 1 side of the test load. Connect the other probe to the MON output (on the rear panel). On the oscilloscope, set the channel A vertical scale to 5 V/div, the channel B vertical scale to 1 V/div, and the horizontal scale to 100 ns/div.
- 4 Turn on the AV-155A-C-EA-EW-EO-LZ3-S5-M-OP1B. The main menu will appear on the LCD.

- 5 To set the AV-155A-C-EA-EW-EO-LZ3-S5-M-OP1B to trigger from the internal clock at a PRF of 10 kHz:
 - 1 The arrow pointer should be pointing at the frequency menu item. If it is not, press the MOVE button until it is.
 - 2 Press the CHANGE button. The frequency submenu will appear. Rotate the ADJUST knob until the frequency is set at 10 kHz.
 - 3 The arrow pointer should be pointing at the "Internal" choice. If it is not, press MOVE until it is.
 - 4 Press CHANGE to return to the main menu.
- 6 To set the delay to 100 ns:
 - 1 Press the MOVE button until the arrow pointer is pointing at the delay menu item.
 - 2 Press the CHANGE button. The delay submenu will appear. Rotate the ADJUST knob until the delay is set at 100 ns.
 - 3 Press CHANGE to return to the main menu.
- 7 To set the OUT pulse width to 100 ns:
 - 1 Press the MOVE button until the arrow pointer is pointing at the "PW" menu item.
 - 2 Press the CHANGE button. The pulse width submenu will appear. Rotate the ADJUST knob until the pulse width is set at 100 ns.
 - 3 The arrow pointer should be pointing at the "Normal" choice. If it is not, press MOVE until it is.
 - 4 Press CHANGE to return to the main menu.
- 8 At this point, nothing should appear on the oscilloscope.
- 9 To enable the output:
 - 1 Press the MOVE button until the arrow pointer is pointing at the output menu item.
 - 2 Press the CHANGE button. The output submenu will appear.
 - 3 Press MOVE until the arrow pointer is pointing at the "ON" choice.

4 Press CHANGE to return to the main menu.

10 To change the OUT output amplitude:

- 1 Press the MOVE button until the arrow pointer is pointing at the AMP1 menu item.
- 2 Press the CHANGE button. The amplitude submenu will appear. Rotate the ADJUST knob until the amplitude is set at -200 mA.
- 3 Observe the oscilloscope. You should see 100 ns wide, -2V pulses (i.e., $-0.2A \times 10\Omega = -2V$) on the probe connected to the main output. The other probe, connected to the MON monitor output, should show 100 ns, -2V pulses (i.e. $-0.2A \times 10\Omega$).
- 4 Press CHANGE to return to the main menu.

11 Try varying the pulse width, by repeating step (7). As you rotate the ADJUST knob, the pulse width on the oscilloscope will change. It should agree with the displayed value.

12 This completes the operational check.

If additional assistance is required:

Tel: (613) 226-5772, Fax: (613) 226-2802
Email: info@avtechpulse.com

CALIBRATION ADJUSTMENTS - INTERNAL TRIMPOTS

The output module has five trimming potentiometers ("trimpots") that can be used to adjust the performance of the output. These trimpots are preset at the factory and should not normally require adjusting after delivery. These controls can be accessed by removing the top panel of the instrument, and by locating the output-stage module. It is near the rear of the instrument.

The locations of the trimpots (designated TP1-TP5) are shown below. All should be accessible through any heatsinking.

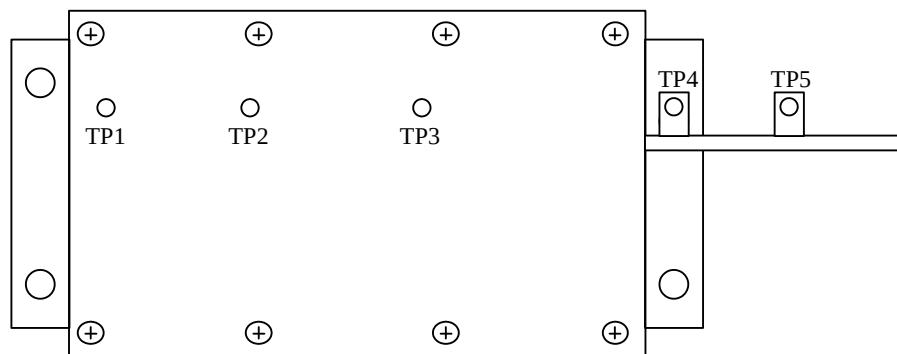

Location of Trimpots

These trimpots can be used to adjust or calibrate the followings properties:

- Current offsets on the main outputs.
- Voltage offsets on the monitor outputs.
- Monitor calibration.
 - Output impedance.

NULLING CONSTANT CURRENT OFFSETS

If a small constant current offset is observed on one of the main outputs, TP2 can be rotated to reduce it to zero. Note that the output stage is incapable of generating a negative current, due to the presence of a diode in series with the output.

NULLING AMPLITUDE-DEPENDENT CURRENT OFFSETS

If a small amplitude-dependent current offset is observed on one of the main outputs, TP1 can be rotated to null it out. Rotate TP1 while adjusting the output amplitude from the front panel, until the offset does not vary with amplitude.

NULLING CONSTANT MONITOR OFFSETS

If a small constant voltage offset is observed on one of the monitor outputs, TP5 can be rotated to reduce it to zero.

ADJUSTING OUTPUT IMPEDANCE

Ideally, the outputs of the pulsed current sources should be independent of the output voltages, within the 0 to -4V compliance voltage range. This condition represents infinite output impedance. If a load voltage/output current dependence is present, the output impedance needs to be adjusted.

To adjust the output impedance, connect a 10Ω load to the output to be adjusted. Set the output amplitude to -0.2A and observe the load voltage on an oscilloscope. The load voltage should have an amplitude of approximately -2V (i.e. $-0.2\text{A} \times 10\Omega = -2\text{V}$). Note the exact value. Now replace the 10Ω load with a 5Ω load. The load voltage should fall by to approximately -1V (i.e. $-0.2\text{A} \times 5\Omega = -1\text{V}$). Note the exact value. If the second voltage is not exactly one-half of the first voltage, adjust TP3 and repeat *both* measurements (10Ω and 5Ω) again. Repeat as required.

ADJUSTING MONITOR CALIBRATION

Just as the current amplitude of the main outputs can exhibit a load-voltage dependence, the voltage amplitude of the current monitors can also exhibit such a dependence if not adjusted properly.

To null out the monitor load voltage dependence, connect a 10Ω load to the main output. Set the output amplitude to -0.2A and observe the monitor voltage on an oscilloscope. The monitor voltage should have an amplitude of approximately -2V. Note the exact value. Now replace the 10Ω load with a 5Ω load. The monitor voltage not change, since the current amplitude has not changed. Note the exact value. If the second voltage is not exactly equal to the first voltage, adjust TP4 and repeat *both* measurements (10Ω and 5Ω) again. Repeat as required.

CALIBRATION ADJUSTMENTS - SOFTWARE PROCEDURES

ADJUSTING AMPLITUDE ACCURACY

If it is found that the output amplitude setting (as set by the front-panel controls or programming commands) does not agree exactly with measured values of amplitude (i.e., by examining the output on an oscilloscope), the amplitude calibration can be updated using software commands.

The following procedure is suggested:

- 1 Connect a precision resistive load to the output. (As an example, suppose 4.0Ω is used.)
- 2 Connect the pulse generator to a computer using the GPIB or RS232 ports.
- 3 Turn on the pulse generator, and set the time controls (frequency, delay, pulse width) to typical values.
- 4 Turn on the outputs.
- 5 Set the output amplitude to its maximum value (-0.2A).
- 6 Observe the voltage across the load. (Continuing the 4.0Ω example, suppose that -0.9V is observed.) From this, calculate the measured current (-0.225A).
- 7 Send one of the following commands to the instrument via the computer interface:
 - 1 `diag:ampl:cal -0.225A`

The internal software compares the supplied measured value to the programmed value, and adjusts the internal calibration data to null out any differences.
- 8 Observe the voltage across the load again. The amplitude setting should now agree with the measured value.

The same procedure can be performed for the offset function, except that the "diag:offset:cal" command is used.

PROGRAMMING YOUR PULSE GENERATOR

KEY PROGRAMMING COMMANDS

The “OP1B Interface Programming Manual” describes in detail how to connect the pulse generator to your computer, and the programming commands themselves. A large number of commands are available; however, normally you will only need a few of these. Here is a basic sample sequence of commands that might be sent to the instrument after power-up, using the internal trigger source:

```
*rst                (resets the instrument)
trigger:source internal (selects internal triggering)
frequency 1 kHz      (sets the frequency to 1 kHz)
pulse:width 100 ns   (sets the pulse width to 100 ns)
pulse:delay 200 ns   (sets the delay to 200 ns)
output on            (turns on the output)
source:current -100 mA (sets the amplitude to -0.1 amperes)
source:current:low -10 mA (sets the offset to -10 mA)
```

For triggering a single event, this sequence would be more appropriate:

```
*rst                (resets the instrument)
trigger:source hold  (turns off all triggering)
pulse:width 100 ns   (sets the pulse width to 100 ns)
output on            (turns on the output)
source:current -100 mA (sets the amplitude to -0.1 amperes)
source:current:low -10 mA (sets the offset to -10 mA)
trigger:source immediate (generates a single non-repetitive trigger event)
trigger:source hold  (turns off all triggering)
output off           (turns off the output)
```

To set the output pulse width to track the trigger pulse width in external mode, use:

```
trigger:source external (selects external triggering)
pulse:width in           (PWOUT = PWIN)
```

To set the output amplitude to track the DC voltage on the EA connector, in external mode, use:

```
trigger:source external (selects external triggering)
source:current external (amplitude controlled by EA connector)
```

To set the output offset to track the DC voltage on the OS connector, in external mode, use:

trigger:source external (selects external triggering)
 source:current:low external (offset controlled by EO connector)

To set the instrument to work as an amplifier (i.e., $I_{OUT} = V_{TRIG} \times -100 \text{ mA/V}$), use:

trigger:source amplify (selects amplifier mode)

These commands will satisfy 90% of your programming needs.

ALL PROGRAMMING COMMANDS

For more advanced programmers, a complete list of the available commands is given below. These commands are described in detail in the “OP1B Interface Programming Manual”. (Note: that manual also includes some commands that are not implemented in this instrument. They can be ignored.)

<u>Keyword</u>	<u>Parameter</u>	<u>Notes</u>
DIAGnostic:		
:AMPLitude		
:CALibration	<numeric value>	[no query form]
:OFFSet		
:CALibration	<numeric value>	[no query form]
LOCAL		
OUTPut:		
:[STATe]	<boolean value>	
:PROTection		
:TRIPped?		[query only]
REMOTE		
[SOURce]:		
:FREQuency		
[:CW FIXed]	<numeric value>	
[SOURce]:		
:CURRent		
[:LEVe]		
[:IMMediate]		
[:AMPLitude]	<numeric value> EXTeRnal	
:LOW	<numeric value> EXTeRnal	
:PROTection		
:TRIPped?		[query only]
[SOURce]:		
:PULSe		
:PERiod	<numeric value>	
:WIDTh	<numeric value> IN	
:DCYCLe	<numeric value>	
:HOLD	WIDTh DCYCLe	
:DELay	<numeric value>	
:GATE		
:LEVe	High LOW	

STATUS:		
:OPERation		
:[EVENT]?		[query only, always returns "0"]
:CONDition?		[query only, always returns "0"]
:ENABLE	<numeric value>	[implemented but not useful]
:QUESTionable		
:[EVENT]?		[query only, always returns "0"]
:CONDition?		[query only, always returns "0"]
:ENABLE	<numeric value>	[implemented but not useful]
SYSTEM:		
:COMMunicate		
:GPIB		
:ADDRESS	<numeric value>	
:SERial		
:CONTRol		
:RTS	ON IBFull RFR	
:[RECeive]		
:BAUD	1200 2400 4800 9600	
:BITS	7 8	
:ECHO	<boolean value>	
:PARity		
:[TYPE]	EVEN ODD NONE	
:SBITS	1 2	
:ERRor		
:[NEXT]?		[query only]
:COUNT?		[query only]
:VERSion?		[query only]
TRIGger:		
:SOURce	INTernal EXTernal MANual HOLD IMMEDIATE AMPLify	
*CLS		[no query form]
*ESE	<numeric value>	
*ESR?		[query only]
*IDN?		[query only]
*OPC		
*SAV	0 1 2 3	[no query form]
*RCL	0 1 2 3	[no query form]
*RST		[no query form]
*SRE	<numeric value>	
*STB?		[query only]
*TST?		[query only]
*WAI		[no query form]

PERFORMANCE CHECK SHEET