

INSTRUCTIONS

MODEL AVB1-3-USB MONOCYCLE GENERATOR

S.N.:

WARRANTY

Avtech Electrosystems Ltd. warrants products of its manufacture to be free from defects in material and workmanship under conditions of normal use. If, within one year after delivery to the original owner, and after prepaid return by the original owner, this Avtech product is found to be defective, Avtech shall at its option repair or replace said defective item. This warranty does not apply to units which have been disassembled, modified or subjected to conditions exceeding the applicable specifications or ratings. This warranty is the extent of the obligation assumed by Avtech with respect to this product and no other warranty or guarantee is either expressed or implied.

TECHNICAL SUPPORT

Phone: 613-226-5772 or 1-800-265-6681

Fax: 613-226-2802 or 1-800-561-1970

E-mail: info@avtechpulse.com

World Wide Web: <http://www.avtechpulse.com>

TABLE OF CONTENTS

WARRANTY.....	2
TABLE OF CONTENTS.....	4
MONOCYCLE GENERATOR TEST ARRANGEMENT.....	5
GENERAL OPERATING INSTRUCTIONS.....	6
PERFORMANCE CHECK SHEET.....	7

MONOCYCLE GENERATOR TEST ARRANGEMENT

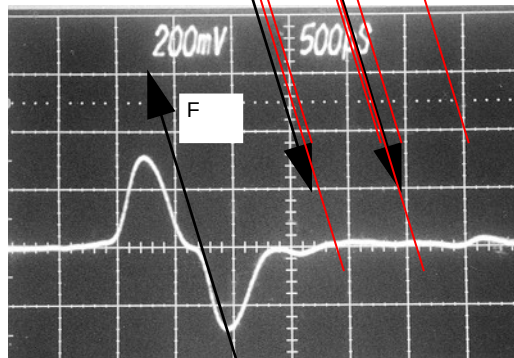
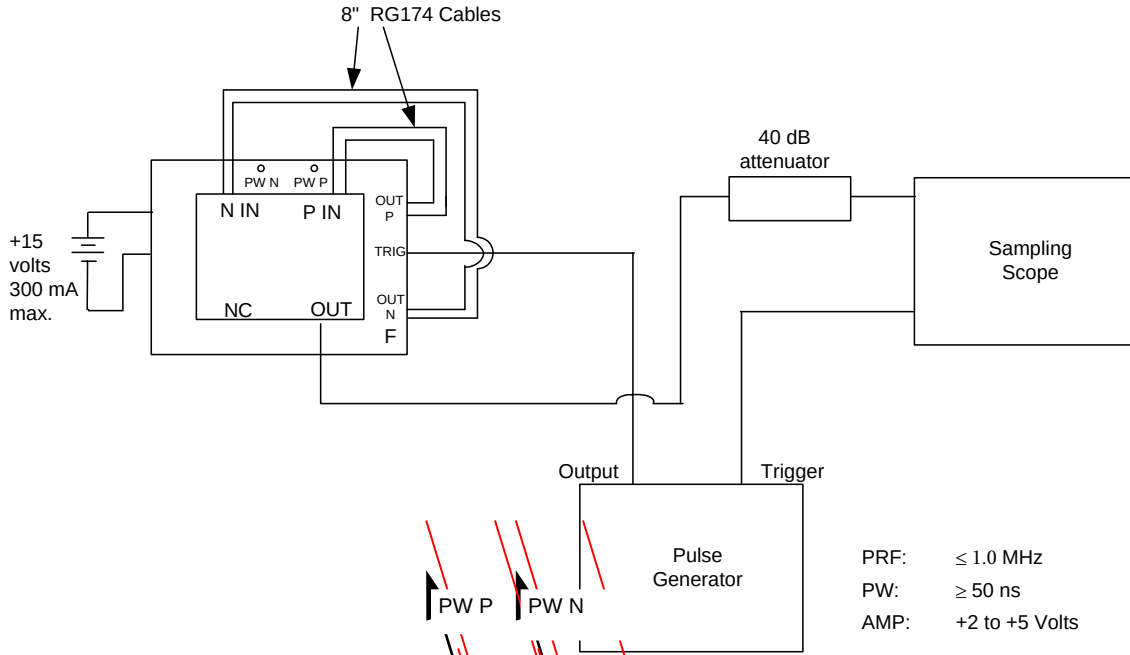

GENERAL OPERATING INSTRUCTIONS

- 1) The bandwidth capability of components and instruments used to display the monocyte generator output signal (attenuators, cables, connectors, etc.) should exceed 10 GHz.
- 2) The use of a 40 db attenuator will insure a peak input signal to the sampling scope of less than one volt.
- 3) In general, the pulse generator delay control should be set in the 100 ns range. Other settings should be as shown in the above diagram. The monocyte generator output is delayed with respect to the trigger input signal by about 53 ns (typically).
- 4) The module shown should be bolted to a heat sink capable of dissipating at least 5 Watts.
- 5) PW P, PW N and F are sensitive to variations in the +15 VDC voltage supply and therefore a well regulated DC supply is required.
- 6) The front panel one turn locking pot "F" controls the relative time separation between the positive excursion and the negative excursion. This setting is independent of PRF for PRF in the range of 0 to 100 kHz but is a function of PRF for PRF in the range of 100 kHz to 1.0 MHz, At the time of shipping, the F control was set to provide 900 MHz at a PRF of 100 kHz. The F setting requires a warm-up period of about 5 minutes to stabilize.
- 7) The ten turn trim pots PW P and PW N respectively control the widths of the positive and negative excursions. At the time of shipping, these controls were set to provide a 900 MHz output and should not require any further adjustment.
- 8) No connection is made to the "NC" SMA connector.
- 9) For additional assistance:

Tel: (613) 226-5772
Fax: (613) 226-2802
Email: info@avtechpulse.com

PERFORMANCE CHECK SHEET