

INSTRUCTIONS

MODEL AVB2-TC-C
400 VOLT MONOCYCLE GENERATOR
WITH 100 - 200 MHz
VARIABLE CENTER FREQUENCY

SERIAL NUMBER: _____

WARRANTY

Avtech Electrosystems Ltd. warrants products of its manufacture to be free from defects in material and workmanship under conditions of normal use. If, within one year after delivery to the original owner, and after prepaid return by the original owner, this Avtech product is found to be defective, Avtech shall at its option repair or replace said defective item. This warranty does not apply to units which have been disassembled, modified or subjected to conditions exceeding the applicable specifications or ratings. This warranty is the extent of the obligation assumed by Avtech with respect to this product and no other warranty or guarantee is either expressed or implied.

TECHNICAL SUPPORT

Phone: 613-226-5772 or 1-800-265-6681

Fax: 613-226-2802 or 1-800-561-1970

E-mail: info@avtechpulse.com

World Wide Web: <http://www.avtechpulse.com>

TABLE OF CONTENTS

WARRANTY	2
TECHNICAL SUPPORT	2
TABLE OF CONTENTS	3
INTRODUCTION	4
AVAILABLE OPTIONS	4
SPECIFICATIONS	5
INSTALLATION	6
VISUAL CHECK	6
PLUGGING IN THE INSTRUMENT	6
FRONT PANEL CONTROLS	8
REAR PANEL CONTROLS	10
GENERAL INFORMATION	11
BASIC TEST ARRANGEMENT	11
MINIMIZING WAVEFORM DISTORTIONS	12
USE 50 TRANSMISSION LINES AND LOADS	12
USE LOW-INDUCTANCE LOADS	12
PREVENTING DAMAGE	12
OPTIONS	13
-OS OPTION	13
-EA OPTION	13
-EF OPTION	13
MECHANICAL INFORMATION	14
TOP COVER REMOVAL	14
ELECTROMAGNETIC INTERFERENCE	14
POWER SUPPLY AND FUSE REPLACEMENT	15
PERFORMANCE CHECK SHEET	17

INTRODUCTION

The AVB2-TC-C monocyte generator can generate monocyte waveforms with amplitudes of up to 400V (peak to peak) and pulse repetition rates of up to 20 kHz. The center frequency of the monocyte is variable using a front-panel one-turn dial, from 100 to 200 MHz.

The AVB2-TC-C may be triggered by the internal oscillator, or by an external TTL-level pulse.

AVAILABLE OPTIONS

The AVB2-TC-C is available with several options:

"-EA" Option: allows the output amplitude to be controlled by an externally generated 0 to +10V analog control voltage.

"-EF" Option: allows the center frequency to be controlled by an externally generated 0 to +10V analog control voltage.

"-OS" Option: allows an externally generated DC offset to be added to the output.

SPECIFICATIONS

Model ¹ :	AVB2-TC-C
Center Frequency Range:	100-200 MHz
Center Frequency Tuning:	Tunes full range, using a front-panel one-turn control ² .
Amplitude ² : (V _{pp} , 50 Ohms)	0 to 400
Maximum pulse repetition rate:	20 kHz
Spurious signals: (WRT peak)	26 dB
Propagation delay:	≤ 100 ns (Ext trig in to pulse out)
Jitter:	± 100 ps (Ext trig in to pulse out)
DC offset option ³ :	Apply required DC offset (± 50 Volts, 250 mA max) to back-panel solder terminals
Trigger required:	Ext trig mode: +5 Volts, 50 to 500 ns (TTL)
Sync delay:	Sync out to pulse out: Variable 0 to 200 ns
Sync output:	+ 3 Volts, 200 ns, will drive 50 Ohm loads
Connectors:	Out, Trig/Sync: BNC
Power requirements:	120/240 Volts (switchable) 50 - 60 Hz
Dimensions (H x W x D):	100 mm x 430 mm x 375 mm (3.9" x 17" x 14.8")

- 1) -C suffix indicates stand-alone lab instrument with internal clock and line powering.
- 2) For electronic control (0 to +10V) of amplitude or frequency suffix the model number with -EA or EF. Electronic control units also include the standard front-panel one-turn controls.
- 3) For DC offset option suffix model number with -OS.

INSTALLATION

VISUAL CHECK

After unpacking the instrument, examine to ensure that it has not been damaged in shipment. Visually inspect all connectors, knobs, and handles. Confirm that a power cord is with the instrument. If the instrument has been damaged, file a claim immediately with the company that transported the instrument.

PLUGGING IN THE INSTRUMENT

Examine the rear of the instrument. There will be a male power receptacle, a fuse holder and the edge of the power selector card visible. Confirm that the power selector card is in the correct orientation.

For AC line voltages of 110-120V, the power selector card should be installed so that the "120" marking is visible from the rear of the instrument, as shown below:

For AC line voltages of 220-240V, the power selector card should be installed so that the "240" marking is visible from the rear of the instrument, as shown below:

If it is not set for the proper voltage, remove the fuse and then grasp the card with a pair of pliers and remove it. Rotate horizontally through 180 degrees. Reinstall the card and the correct fuse.

In the 120V setting, a 1.0A slow blow fuse is required. In the 240V setting, a 0.5A slow blow fuse is required.

FRONT PANEL CONTROLS

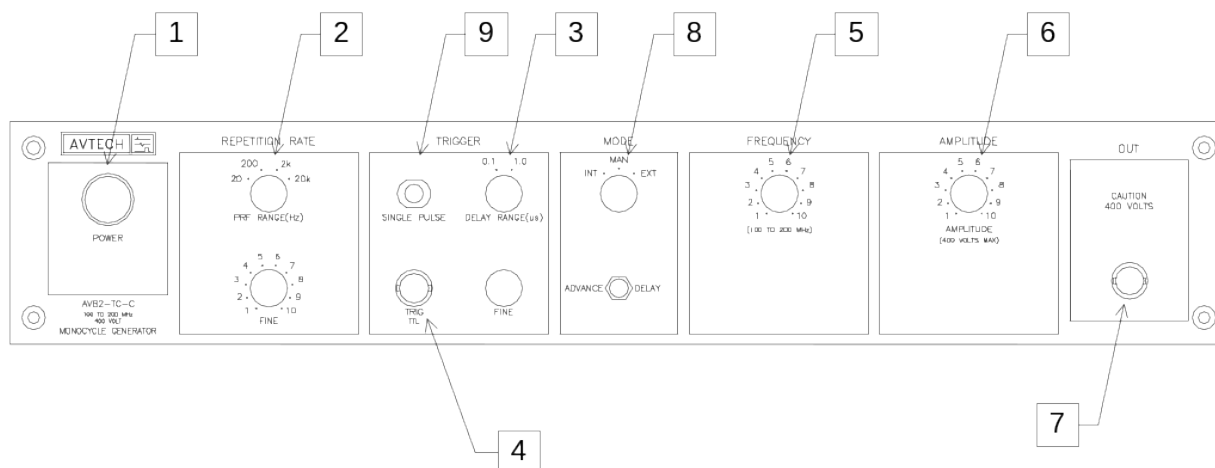

1. **POWER Switch.** The POWER push button switch applies AC prime power to the primaries of the transformer, turning the instrument on. The push button lamp (#382 type) is connected to the internal +15V DC supply.
2. **REPETITION RATE Controls.** Varies PRF as follows:

RANGE 1	2 Hz - 20 Hz
RANGE 2	20 Hz - 200 Hz
RANGE 3	200 Hz - 2 kHz
RANGE 4	2 kHz - 20 kHz
3. **DELAY Control.** Controls the relative delay between the reference output pulse provided at the TRIG output (4) and the main output (7). This delay is variable over the range of 0 to about 1.0 us. The TRIG output precedes the main output when the ADVANCE-DELAY switch is in the ADVANCE position and lags when the switch is in the DELAY position.
4. **TRIG Connector.** When the MODE switch (item 8) is set to the “EXT” position, a TTL-level pulse applied to this connector will trigger the instrument. The instrument triggers on the rising edge of this input. The input impedance of this input is 1 kΩ. (Depending on the length of cable attached to this input, and the source driving it, it may be desirable to add a coaxial 50 Ohm terminator to this input to provide a proper transmission line termination. The Pasternack (www.pasternack.com) PE6008-50 BNC feed-thru 50 Ohm terminator is suggested for this purpose.)

When the MODE switch (item 8) is set to the “INT” position, this connector is used as an output that generates a 200 ns wide TTL-level pulse for each trigger event. This output can be used to trigger an oscilloscope, or other test equipment. The

separation between the main output pulse and the TRIG output pulse is controlled by the DELAY controls and the ADVANCE/DELAY switch (item 8). For this output to operate correctly, the delay setting must be less than the period.

5. FREQUENCY Control. This one-turn control varies the center frequency of the main output.
6. AMP Control. The output pulse amplitude is controlled by means of this one-turn dial over the range of approximately 150 volts to 400 volts.
7. OUT. This is the main output connector. A 50 Ohm load is required for proper operation.
8. INT/EXT/MAN Mode Switch. With this switch in the INT position, the repetition rate of the unit is controlled by an internal oscillator, which in turn is controlled by the REPETITION RATE controls. With the switch in the EXT position, the unit requires a 50 ns (or wider) TTL level pulse applied at the TRIG input in order to trigger the output stages. For a single pulse output, the switch should be in the "MAN" position and then push the SINGLE PULSE pushbutton (9).

The PULSE DELAY controls (item 9) and DELAY MODE switch (item 8) affect the operation of this output. When the DELAY MODE switch is in the "Main Out Delayed" position, the pulses on the main output (item 18) and the four logic outputs (items 11-14) are delayed relative to the SYNC OUT pulse by a time controlled by the PULSE DELAY controls (item 9).

When the DELAY MODE switch is in the "Main Out Advanced" position, the pulses on the main output (item 18) and the four logic outputs (items 11-14) are advanced relative to the SYNC OUT pulse by a time controlled by the PULSE DELAY controls (item 9).

When the DELAY MODE switch is in the "Double Pulse" position, the SYNC OUT pulse is approximately coincident with the first pulse of the pair of pulses on the main output.

For this output to operate correctly, the delay setting must be less than the period.

9. SINGLE PULSE Pushbutton. When the INT/EXT/MAN switch is in the "MAN" position, the instrument can be triggered by pressing this pushbutton. A single pulse is generated for each button press.

REAR PANEL CONTROLS

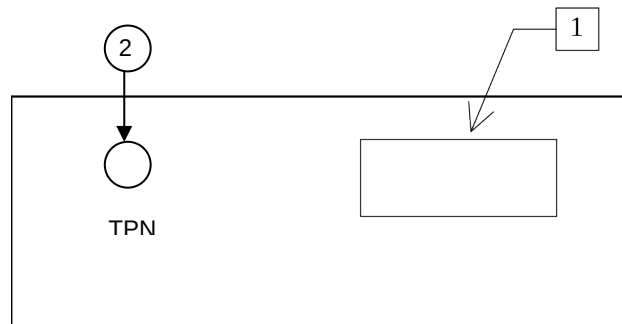

1. AC POWER INPUT. A three-pronged recessed male connector is provided on the back panel for AC power connection to the instrument. Also contained in this assembly is a slow-blow fuse and a removable card that can be removed and repositioned to switch between 120V AC in and 240V AC in.

For AC line voltages of 110-120V, the power selector card should be installed so that the “120” marking is visible from the rear of the instrument.

For AC line voltages of 220-240V, the power selector card should be installed so that the “240” marking is visible from the rear of the instrument.

If it is not set for the proper voltage, remove the fuse and then grasp the card with a pair of pliers and remove it. Rotate horizontally through 180 degrees. Reinstall the card and the correct fuse.

In the 120V setting, a 1.0A slow blow fuse is required. In the 240V setting, a 0.5A slow blow fuse is required. See the “Installation” section for more details.

2. TPN. A one-turn control used to adjust the time separation between the peak of the positive swing and the peak of the negative swing if the front panel one turn frequency control is out of calibration.

GENERAL INFORMATION

BASIC TEST ARRANGEMENT

The AVB2-TC-C should be tested with a sampling oscilloscope with a bandwidth of at least 1 GHz to properly observe the high-speed waveform. A typical test arrangement is shown below:

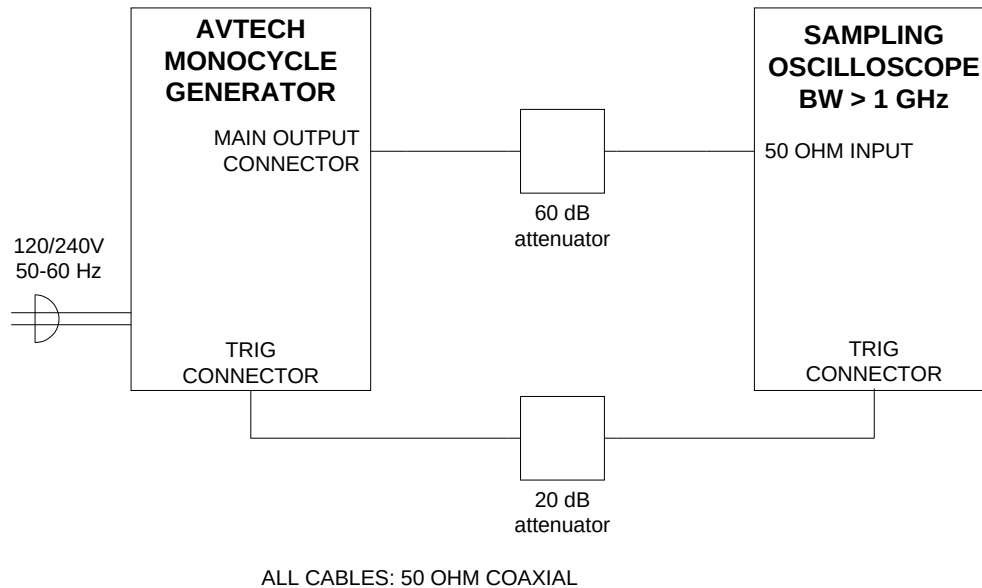

The attenuators are required to prevent damage to the sampling oscilloscope. A 60 dB attenuator with sufficient voltage rating should be used on the main output.

The output frequency is controlled by the front panel one-turn FREQUENCY control. Clockwise rotation of the control increases the frequency of the output monocycle (or decreases the pulse width of the output waveform).

The output pulse amplitude is controlled by means of the one turn potentiometer (AMP). The output amplitude may be varied from about 150 to 400 Volts peak to peak. For lower output amplitudes (and for lower spurious at reduced amplitudes) it is recommended that external attenuators be used.

MINIMIZING WAVEFORM DISTORTIONS

USE 50Ω TRANSMISSION LINES AND LOADS

Connect the load to the pulse generator with 50Ω transmission lines (e.g. RG-58 or RG-174 cable).

This instrument requires a 50Ω load for proper operation. It will not properly drive a high-impedance load. The output stage will be damaged if it is operated into an open circuit (or any other high impedance). Failures due to improper output loading are not covered by the warranty.

USE LOW-INDUCTANCE LOADS

Lenz's Law predicts that for an inductive voltage spike will be generated when the current through an inductance changes. Specifically, $V_{\text{SPIKE}} = L \times di_{\text{LOAD}}/dt$, where L is the inductance, i_{LOAD} is the load current change, and t is time. For this reason, it is important to keep any parasitic in the load low. This means keeping wiring short, and using low inductance components. In particular, wire-wound resistors should be avoided.

PREVENTING DAMAGE

The AVB2-TC-C may fail if triggered at a PRF greater than 20 kHz.

This unit is designed to operate into a load impedance of 50 Ohms and the output stage will be damaged if it is operated into an open circuit (or any other high impedance). Failures due to improper output loading are not covered by the warranty.

The lifetime of the switching elements in the pulse generator module is proportional to the running time of the instrument. For this reason the prime power to the instrument should be turned off when the instrument is not in use.

OPTIONS

The AVB2-TC-C is available with these options:

-OS OPTION

This option allows an externally generated DC offset to be added to the output. The desired DC offset is applied to the back panel OS terminal, which is connected to the output centre conductor through a high-quality RF inductor. Do not exceed 50V, 250 mA.

-EA OPTION

To control the output amplitude with an external voltage, set the rear-panel switch to the "EXT" position and apply 0 to +10V to connector A ($R_{IN} \geq 10k\Omega$).

-EF OPTION

To control the output center frequency with an external voltage, set the rear-panel switch to the "EXT" position and apply 0 to +10V to connector F ($R_{IN} \geq 10k\Omega$).

MECHANICAL INFORMATION

TOP COVER REMOVAL

The interior of the instrument may be accessed by removing the four Phillips screws on the top panel. With the four screws removed, the top cover may be slid back (and off).

ELECTROMAGNETIC INTERFERENCE

To prevent electromagnetic interference with other equipment, all used outputs should be connected to shielded 50Ω loads using shielded 50Ω coaxial cables. Unused outputs should be terminated with shielded 50Ω BNC terminators or with shielded BNC dust caps, to prevent unintentional electromagnetic radiation. All cords and cables should be less than 3m in length.

POWER SUPPLY AND FUSE REPLACEMENT

This instrument has three main fuses, plus two spares. One, which protects the AC input, is located in the rear-panel power entry module, as described in the “Rear Panel Controls” section of this manual. If the power appears to have failed, check the AC fuse first.

The other two fuses (plus two spares) are located on the internal DC power supply, as shown below:

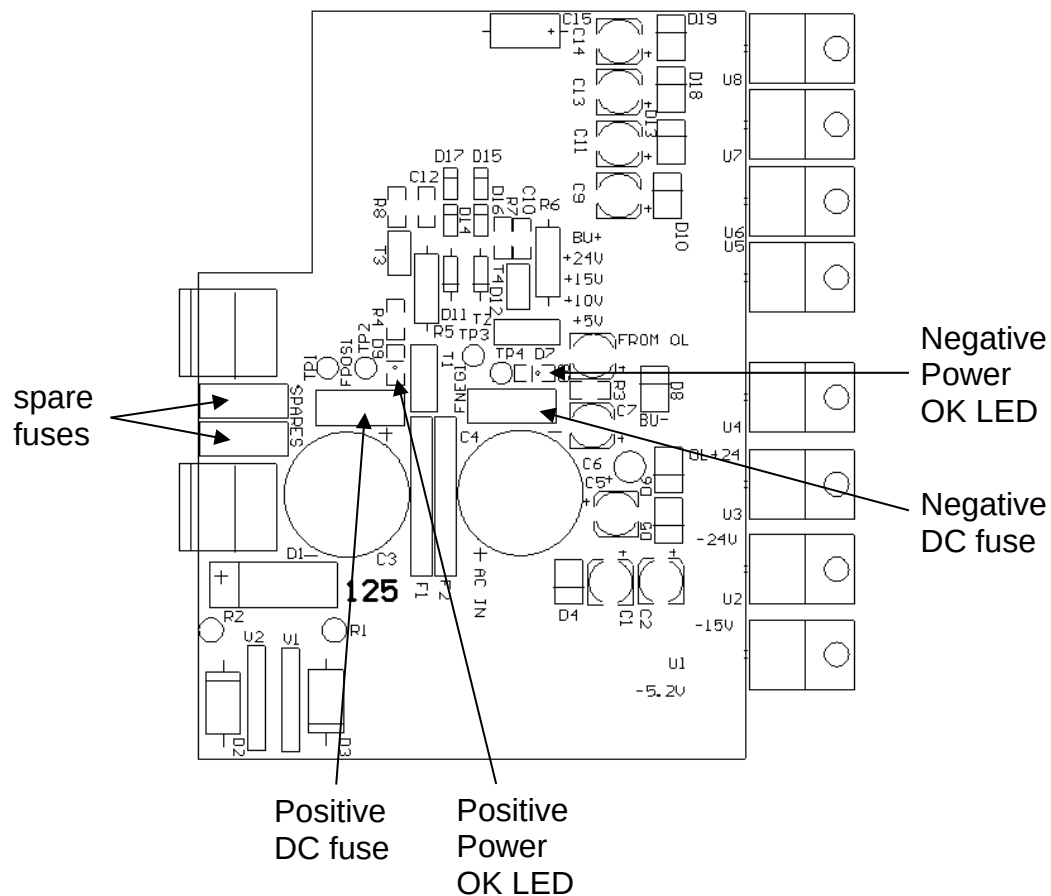

The four fuses on this circuit board are 1.0A slow-blow fuses, Littlefuse part number R452001. (This fuse can be ordered from Digikey, www.digikey.com. The Digikey part number is F1343CT-ND).

If you suspect that the DC fuses are blown, follow this procedure:

1. Remove the top cover, by removing the four Phillips screws on the top cover and then sliding the cover back and off.
2. Locate the two “Power OK” LEDs on the power supply circuit board, as illustrated above.

3. Turn on the instrument.
4. Observe the “Power OK” LEDs. If the fuses are not blown, the two LEDs will be lit (bright red). If one of the LEDs is not lit, the fuse next to it has blown.
5. Turn off the instrument.
6. If a fuse is blown, use needle-nose pliers to remove the blown fuse from its surface-mount holder.
7. Replace the fuse. (Two spare 1.0 Amp fuses are provided on the circuit board. They may be transferred to the active fuse locations using needle-nose pliers.)

PERFORMANCE CHECK SHEET