

INSTRUCTIONS

MODEL AVE1-C MONOCYCLE GENERATOR

S.N.:

WARRANTY

Avtech Electrosystems Ltd. warrants products of its manufacture to be free from defects in material and workmanship under conditions of normal use. If, within one year after delivery to the original owner, and after prepaid return by the original owner, this Avtech product is found to be defective, Avtech shall at its option repair or replace said defective item. This warranty does not apply to units which have been disassembled, modified or subjected to conditions exceeding the applicable specifications or ratings. This warranty is the extent of the obligation assumed by Avtech with respect to this product and no other warranty or guarantee is either expressed or implied.

TECHNICAL SUPPORT

Phone: 613-226-5772 or 1-800-265-6681

Fax: 613-226-2802 or 1-800-561-1970

E-mail: info@avtechpulse.com

World Wide Web: <http://www.avtechpulse.com>

TABLE OF CONTENTS

WARRANTY.....	2
TABLE OF CONTENTS.....	4
FIG. 1: PULSE GENERATOR TEST ARRANGEMENT.....	5
GENERAL OPERATING INSTRUCTIONS.....	6
FIG. 2: FRONT PANEL CONTROLS.....	7
FRONT PANEL CONTROLS.....	8
FIG. 3: BACK PANEL CONTROLS.....	9
BACK PANEL CONTROLS.....	10
TOP COVER REMOVAL.....	10
-R5 RACK MOUNT KIT.....	10
POWER SUPPLY AND FUSE REPLACEMENT.....	11
PERFORMANCE CHECK SHEET.....	13

FIG. 1: PULSE GENERATOR TEST ARRANGEMENT

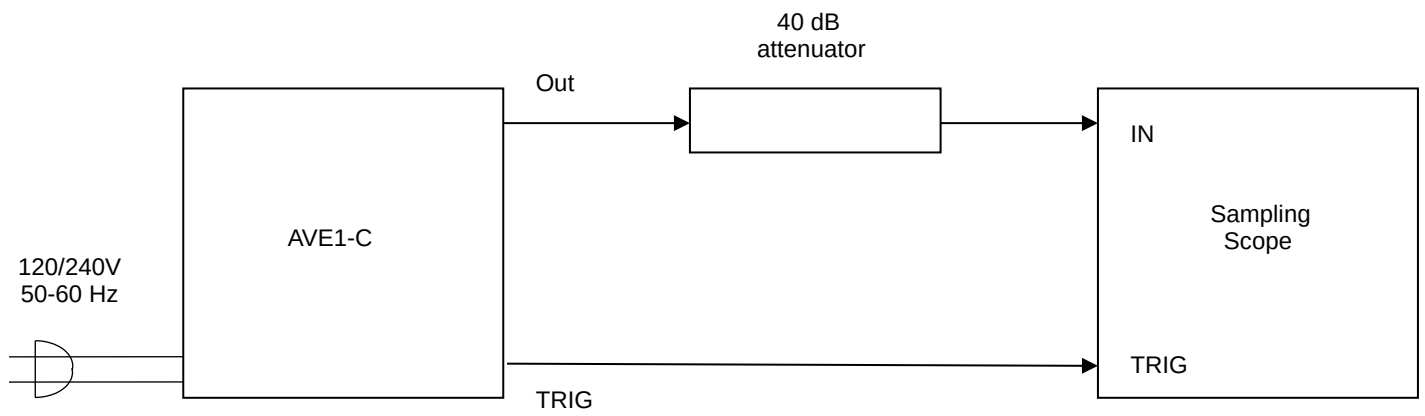

GENERAL OPERATING INSTRUCTIONS

- 1) The bandwidth capability of components and instruments used to display the pulse generator output signal (attenuators, cables, connectors, etc.) should exceed 10 GHz.
- 2) The use of 40 dB attenuator at the sampling scope vertical input channel will insure a peak input signal to the sampling scope of less than one Volt.
- 3) The TRIG output channel provides a 500 mV 20 ns wide pulse to fifty Ohms. The sampling scope should be set to trigger on the positive edge of the TRIG pulse.
- 4) To obtain a stable output display the PRF control on the front panel should be set mid-range while the PRF range switch may be in any range (except EXT). The front panel DELAY controls and the scope triggering controls are then adjusted to obtain a stable output. The scope may then be used to set the desired PRF by rotating the PRF control and by means of the PRF range switch.
- 5) The unit may be tuned from about 1500 MHz to about 3000 MHz using the front panel control. Clockwise rotation of the pot tends to decrease the period (or increase the frequency).
- 6) An external clock may be used to control the output PRF of the AVE1 unit by setting the front panel PRF range switch in the EXT position and applying a 50 ns (or wider) TTL level pulse to the TRIG BNC connector input.
- 7) The AVE1-C unit can be converted from 120 to 240V 50-60 Hz operation by adjusting the voltage selector card in the rear panel fused voltage selector-cable connector assembly.
- 8) For additional assistance:

Tel: 613-226-5772
Fax: 613-226-2802
Email: info@avtechpulse.com

FIG. 2: FRONT PANEL CONTROLS

FRONT PANEL CONTROLS

- 1) ON-OFF Switch. Applies basic prime power to all stages.
- 2) PRF Control. With this range switch in the 1K, 10K, 100K or 1M positions, the PRF of the AVE unit is controlled via an internal clock which in turn is controlled by the PRF controls. With the range switch in the EXT position, the AVE unit requires a 50 ns (or wider) TTL level pulse applied at the TRIG input in order to trigger the output stages.
- 3) DELAY Control. Controls the relative delay between the reference output pulse provided at the TRIG output (4) and the main output (5). This delay is variable over the range of 0 to about 150 ns.
- 4) TRIG Output. When triggered internally, this output precedes the main output (5) and is used to trigger the scope time base. The output is a 500 mV 20 ns (approx.) pulse capable of driving a fifty Ohm load. Set scope to trigger on positive edge. The external trigger signal is applied at this point when the PRF INT toggle switch is in the EXT position.
- 5) OUT. SMA output connect provides output to a fifty Ohm load.
- 6) Frequency: One turn control varies the frequency of the monocycle output from 1500 to 3000 MHz.

FIG. 3: BACK PANEL CONTROLS

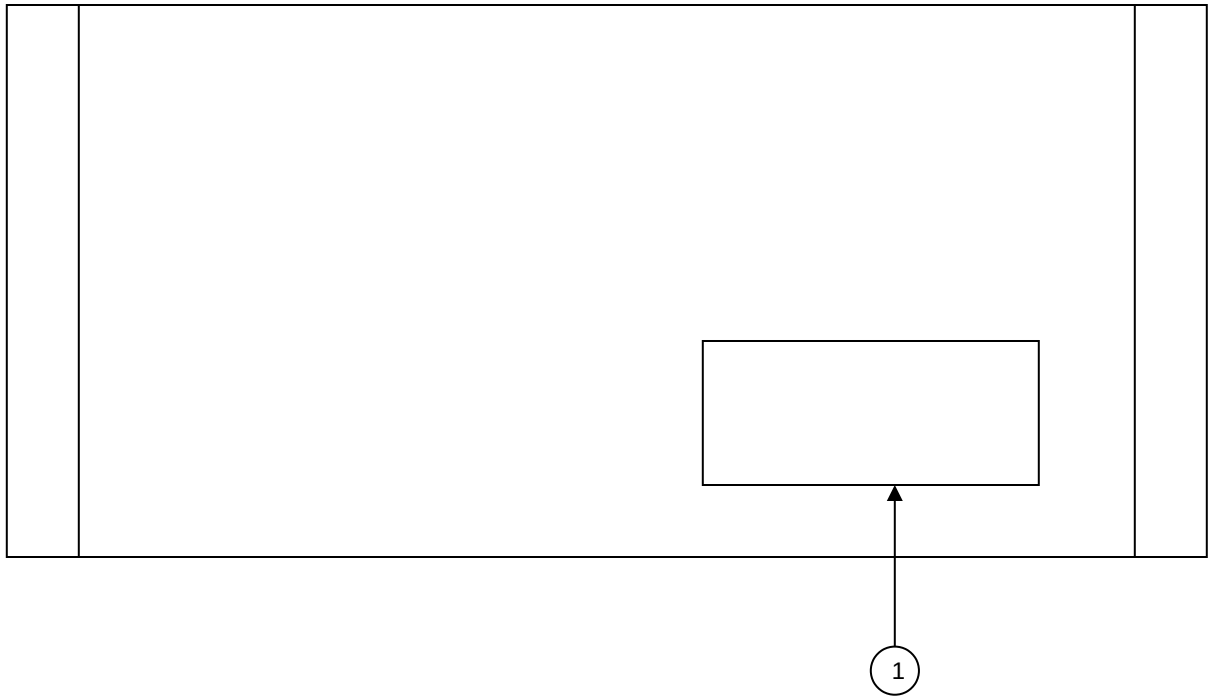

BACK PANEL CONTROLS

- 1) FUSED CONNECTOR, VOLTAGE SELECTOR. The detachable power cord is connected at this point. In addition, the removable cord is adjusted to select the desired input operating voltage. The unit also contains the main power fuse. (0.5A SB).

TOP COVER REMOVAL

Top cover may be removed by removing the 4 Phillips screws on the top of the instrument. The top cover may then be slid back and off.

-R5 RACK MOUNT KIT

The -R5 rack mount kit may be installed after first removing the one Phillips screw on the side panel adjacent to the front handle.

POWER SUPPLY AND FUSE REPLACEMENT

This instrument has three fuses (plus one spare). One, which protects the AC input, is located in the rear-panel power entry module, as described in the “Rear Panel Controls” section of this manual. If the power appears to have failed, check the AC fuse first.

The other two fuses (plus one spare) are located on the internal DC power supply, as shown below:

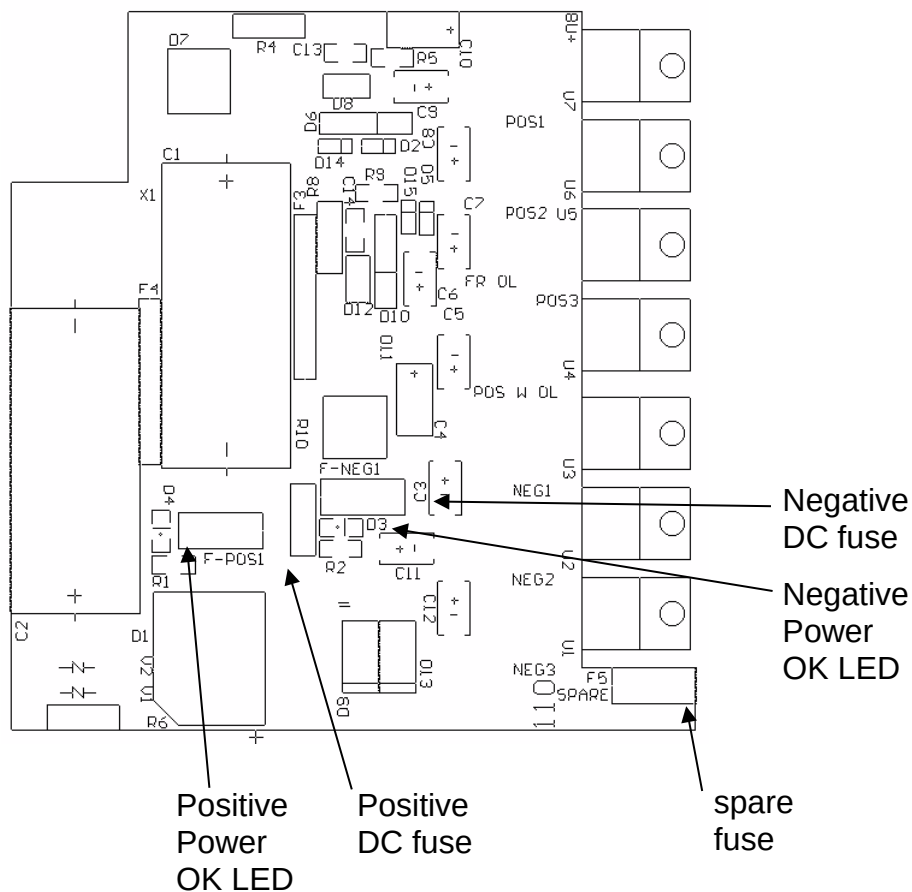

The spare fuse may be used to replace one of the other fuses, if required.

The three fuses on this circuit board are 0.5A slow-blow fuses, Littlefuse part number R452.500. (This fuse can be ordered from Digikey, www.digikey.com. The Digikey part number is F1341CT-ND).

If you suspect that the DC fuses are blown, follow this procedure:

1. Remove the top cover, by removing the four Phillips screws on the top cover and then sliding the cover back and off.
2. Locate the two “Power OK” LEDs on the power supply circuit board, as illustrated above.
3. Turn on the instrument.
4. Observe the “Power OK” LEDs. If the fuses are not blown, the two LEDs will be lit (bright red). If one of the LEDs is not lit, the fuse next to it has blown.
5. Turn off the instrument.
6. If a fuse is blown, use needle-nose pliers to remove the blown fuse from its surface-mount holder.
7. Replace the fuse.

PERFORMANCE CHECK SHEET