



AVTECH ELECTROSYSTEMS LTD.

NANOSECOND WAVEFORM ELECTRONICS
SINCE 1975

P.O. BOX 265
OGDENSBURG, NY
U.S.A. 13669-0265
TEL: (315) 472-5270
FAX: (613) 226-2802

TEL: 1-800-265-6681
FAX: 1-800-561-1970

e-mail: info@avtechpulse.com
<http://www.avtechpulse.com/>

BOX 5120, LCD MERIVALE
OTTAWA, ONTARIO
CANADA K2C 3H4
TEL: (613) 226-5772
FAX: (613) 226-2802

INSTRUCTIONS

MODEL AVG-1

0 to 250V, ≤ 4 ns

IMPULSE GENERATOR

SERIAL NUMBER: _____

WARRANTY

Avtech Electrosystems Ltd. warrants products of its manufacture to be free from defects in material and workmanship under conditions of normal use. If, within one year after delivery to the original owner, and after prepaid return by the original owner, this Avtech product is found to be defective, Avtech shall at its option repair or replace said defective item. This warranty does not apply to units which have been disassembled, modified or subjected to conditions exceeding the applicable specifications or ratings. This warranty is the extent of the obligation assumed by Avtech with respect to this product and no other warranty or guarantee is either expressed or implied.

TECHNICAL SUPPORT

Phone: 613-226-5772 or 1-800-265-6681

Fax: 613-226-2802 or 1-800-561-1970

E-mail: info@avtechpulse.com

World Wide Web: <http://www.avtechpulse.com>

TABLE OF CONTENTS

WARRANTY.....2

TECHNICAL SUPPORT.....2

TABLE OF CONTENTS.....3

INTRODUCTION.....4

AVAILABLE OPTIONS.....4

SPECIFICATIONS.....5

BASIC TEST ARRANGEMENT.....6

CONNECTORS.....6

GENERAL OPERATING NOTES.....7

PERFORMANCE CHECK SHEET.....8

Manual Reference: /fileserver1/officefiles/instructword/avg/OBS/AVG-1.edition1.sxw.
Last modified February 29, 2024.
Copyright © 2024 Avtech Electrosystems Ltd, All Rights Reserved.

INTRODUCTION

The AVG-1 is a high performance DC-powered module capable of generating up to 250V impulses into 50 Ω loads at repetition rates up to 50 kHz. The pulse width is fixed at ≤ 4 ns.

Instruments with the "-P" model suffix can generate 0 to +250V, whereas instruments with the "-N" model suffix can generate 0 to -250V.

The AVG-1 must be triggered by an external TTL pulse (> 50 ns) applied to the "IN" connector.

The output is designed to drive 50 Ω loads. (A 50 Ω load is required for proper operation.) The output is AC-coupled.

This instrument is intended for use in research and development laboratories.

AVAILABLE OPTIONS

The AVG-1 is available with several options:

-EA Option: the output amplitude can be controlled by an externally generated 0 to +10V analog control voltage.

-M Option: a monitor output is provided.

-OS Option: an externally generated DC offset can be added to the output.

SPECIFICATIONS

Model:	AVG-1
Amplitude ¹ : (50Ω load)	0 to 250 V
Pulse width: (at 20% rise time)	≤ 4 ns (typically 3 ns)
Rise time:	≤ 2 ns
Fall time:	≤ 2 ns
PRF:	0 to 50 kHz
Polarity ² :	Positive or negative
Propagation delay:	≤ 50 ns (Ext trig in to pulse out)
Jitter:	± 100 ps (Ext trig in to pulse out)
DC offset:	Optional ³ : Apply required DC offset (± 50 Volts, 250 mA max) to back-panel solder terminals
Trigger required:	+5 Volts, 50 to 500 ns (TTL)
Monitor output:	Optional ⁴ : Provides a 20 dB attenuated coincident replica of main output
Connectors:	Out: SMA, In: SMA, Power: Solder terminal
Dimensions: (H x W x D)	43 mm x 76 mm x 152 mm (1.7" x 3.0" x 6.0")
Power:	+15 Volts, 350 mA
Chassis material:	Cast aluminum, blue enamel
Temperature range:	Any, +5°C to +40°C
Mounting:	It is recommended that the module be bolted to a heatsink, for cooling.

1) For electronic control (0 to + 10 V) of amplitude, suffix the model number with -EA. Electronic control units also include standard front-panel one-turn controls.

2) Indicate desired polarity by suffixing model number with -P or -N (i.e. positive or negative). AVX-1 transformer may be used to invert polarity.

3) For DC offset option suffix model number with -OS.

4) For monitor option add suffix -M.

BASIC TEST ARRANGEMENT

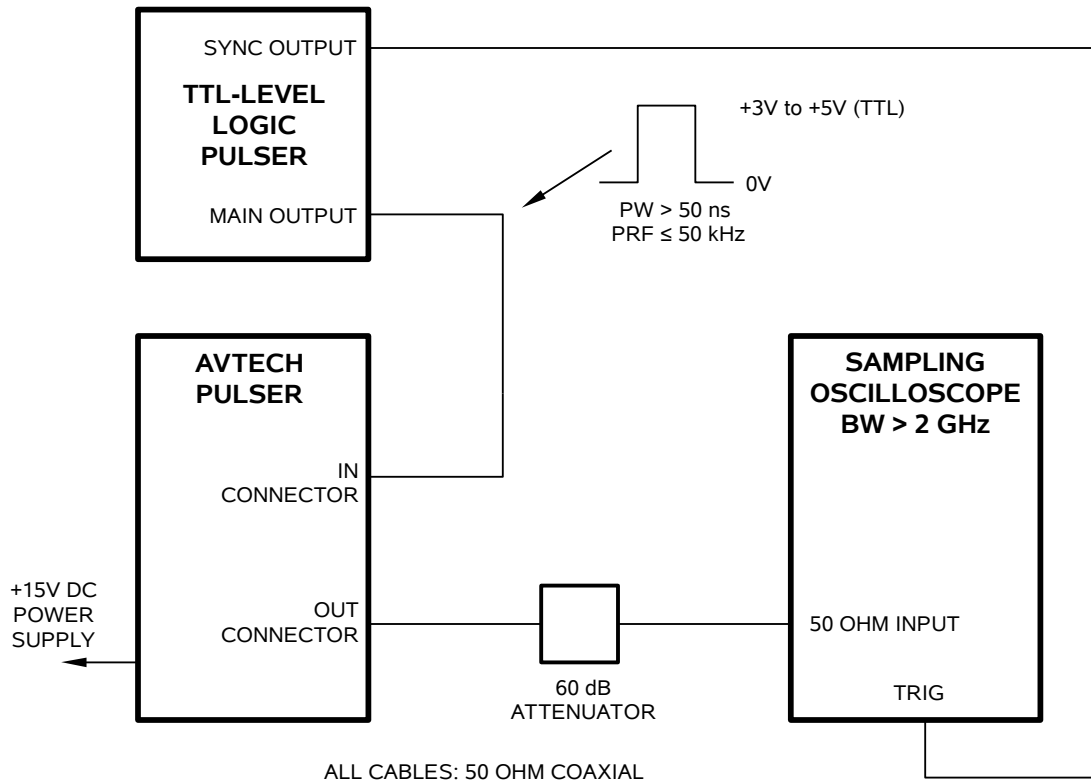

CONNECTORS

The location of the IN and OUT connectors, and the amplitude control, are shown in the photo below. The +15V and GND power terminals are on the opposite end of the module.

GENERAL OPERATING NOTES

- 1) The bandwidth capability of components and instruments used to display the pulse generator output signal (attenuators, cables, connectors, etc.) should exceed 2 GHz.
- 2) The use of 60 dB attenuator on the output will insure a peak input signal to the sampling scope of less than one volt.
- 3) In general, the source pulse generator trigger delay control should be set in the 0.1 to 1.0 us range, for proper positioning of the output pulse on the sampling oscilloscope display.
- 4) WARNING: The module may fail if triggered at a PRF greater than 50 kHz.
- 5) The output pulse amplitude is controlled by means of the one turn potentiometer (AMP).
- 6) To DC offset the output pulse connect a DC power supply set to required DC offset value to the terminals marked "OS". The maximum attainable DC offset voltage is +50 volts. (Option).
- 7) The monitor output port (M) provides a coincident attenuated ($\div 10$) replica of the main output to a 50 ohm load. (Option).
- 8) It is recommended that the module be bolted to a heatsink, for cooling purposes. This will improve the stability of the output, by reducing thermal drift.
- 9) For additional information:

Tel: 613-226-5772
Fax: 613-226-2802
Email: info@avtechpulse.com

PERFORMANCE CHECK SHEET