

INSTRUCTIONS

MODEL AVG-4A-EA-P-FOICA IMPULSE GENERATOR

S.N.:

WARRANTY

Avtech Electrosystems Ltd. warrants products of its manufacture to be free from defects in material and workmanship under conditions of normal use. If, within one year after delivery to the original owner, and after prepaid return by the original owner, this Avtech product is found to be defective, Avtech shall at its option repair or replace said defective item. This warranty does not apply to units which have been disassembled, modified or subjected to conditions exceeding the applicable specifications or ratings. This warranty is the extent of the obligation assumed by Avtech with respect to this product and no other warranty or guarantee is either expressed or implied.

TECHNICAL SUPPORT

Phone: 613-226-5772 or 1-800-265-6681

Fax: 613-226-2802 or 1-800-561-1970

E-mail: info@avtechpulse.com

World Wide Web: <http://www.avtechpulse.com>

TABLE OF CONTENTS

WARRANTY.....2

TABLE OF CONTENTS.....4

FIG. 1: IMPULSE GENERATOR TEST ARRANGEMENT.....5

GENERAL OPERATING INSTRUCTIONS.....6

PERFORMANCE CHECK SHEET.....7

FIG. 1: IMPULSE GENERATOR TEST ARRANGEMENT

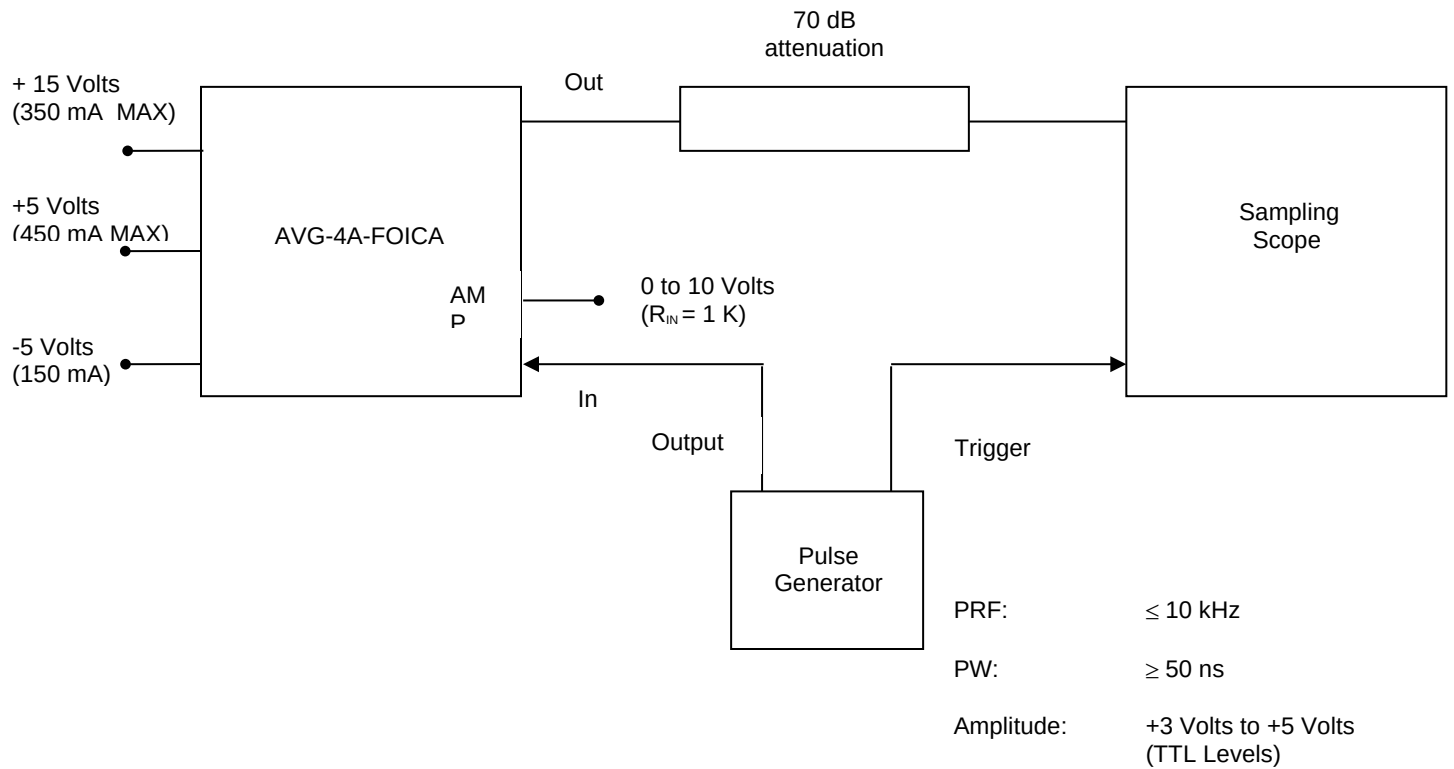

GENERAL OPERATING INSTRUCTIONS

- 1) The bandwidth capability of components and instruments used to display the pulse generator output signal (attenuators, cables, connectors, etc.) should exceed one gigahertz.
- 2) This model dissipates up to 8 Watts and so it is essential that it be securely bolted to a heatsink.
- 3) The use of 70 dB attenuator will insure a peak input signal to the sampling scope of less than one Volt.
- 4) The output amplitude is controlled by the 0 to +10 VDC voltage applied to the amp solder terminal ($R_{IN} \approx 1 \text{ K}$).
- 5) In general, the pulse generator trigger delay control should be set in the 100 ns range. Other settings should be as shown in the above diagram. The impulse generator output is delayed with respect to the trigger input signal by about 70 ns (typically).
- 6) The impulse generator can withstand an infinite VSWR on the output port.
- 7) For additional assistance:
Tel: (613) 226-5772
Fax: (613) 226-2802
E-mail: info@avtechpulse.com

PERFORMANCE CHECK SHEET