



AVTECH ELECTROSYSTEMS LTD.

NANOSECOND WAVEFORM ELECTRONICS
SINCE 1975

□ P.O. BOX 265
OGDENSBURG, NY
U.S.A. 13669-0265

TEL: 888-670-8729 (USA & Canada) or +1-613-226-5772 (Intl)
FAX: 800-561-1970 (USA & Canada) or +1-613-226-2802 (Intl)

info@avtechpulse.com - <http://www.avtechpulse.com/>

☒ BOX 5120, LCD MERIVALE
OTTAWA, ONTARIO
CANADA K2C 3H4

INSTRUCTIONS

MODEL AVI-V-2L

0 TO 40 VOLTS, 100 kHz, 1 - 10 ns

HIGH SPEED PULSE GENERATOR MODULE

WITH 500 ps RISE & FALL TIMES

SERIAL NUMBER: _____

WARRANTY

Avtech Electrosystems Ltd. warrants products of its manufacture to be free from defects in material and workmanship under conditions of normal use. If, within one year after delivery to the original owner, and after prepaid return by the original owner, this Avtech product is found to be defective, Avtech shall at its option repair or replace said defective item. This warranty does not apply to units which have been disassembled, modified or subjected to conditions exceeding the applicable specifications or ratings. This warranty is the extent of the obligation assumed by Avtech with respect to this product and no other warranty or guarantee is either expressed or implied.

TECHNICAL SUPPORT

Phone: 888-670-8729 (USA & Canada) or +1-613-226-5772 (Intl)

Fax: 800-561-1970 (USA & Canada) or +1-613-226-2802 (Intl)

E-mail: info@avtechpulse.com

World Wide Web: <http://www.avtechpulse.com>

TABLE OF CONTENTS

WARRANTY.....2

TECHNICAL SUPPORT.....2

TABLE OF CONTENTS.....3

INTRODUCTION.....4

AVAILABLE OPTIONS.....4

SPECIFICATIONS.....5

CONTROLS.....6

BASIC TEST ARRANGEMENT.....8

GENERAL OPERATING NOTES.....8

MINIMIZING WAVEFORM DISTORTIONS..... 10

USE 50 OHM TRANSMISSION LINES AND LOADS..... 10

USE LOW-INDUCTANCE LOADS..... 10

PREVENTING DAMAGE..... 10

PERFORMANCE CHECK SHEET..... 11

Manual Reference: /files/server1/officefiles/instructword/avi/AVI-V-2L,ed1.odt.
Last modified February 29, 2024.
Copyright © 2024 Avtech Electrosystems Ltd, All Rights Reserved.

INTRODUCTION

The AVI-V-2L is a high performance DC-powered module capable of generating up to 40V into 50Ω loads at repetition rates up to 100 kHz. The output pulse width is variable from 1 to 10 ns. The rise time and fall times are 500 ps or less (20%-80%).

Instruments with the "-P" model suffix can generate 0 to +40V, whereas instruments with the "-N" model suffix can generate 0 to -40V.

The AVI-V-2L must be triggered by an external TTL pulse (> 50 ns) applied to the "IN" connector.

The output is designed to drive 50Ω loads. (A 50Ω load is required for proper operation.) The output is AC-coupled.

This instrument is intended for use in research and development laboratories.

AVAILABLE OPTIONS

The AVI-V-2L is available with the following option(s):

-EA Option: the output amplitude can be controlled by an externally generated 0 to +10V analog control voltage, instead of the standard trimpot control.

-EW Option: the output pulse width can be controlled by an externally generated 0 to +10V analog control voltage, instead of the standard trimpot control.

-OS Option: an externally generated DC offset can be added to the output.

SPECIFICATIONS

Model:	AVI-V-2L
Amplitude ^{1,2} : (50Ω load required)	0 to 40 V, variable
Rise time (20%-80%):	≤ 500 ps
Fall time (80%-20%):	≤ 500 ps
Pulse width (FWHM) ² :	1 to 10 ns
Maximum pulse repetition frequency (PRF):	100 kHz
Propagation delay:	≤ 250 ns
Polarity ³ :	Positive or negative (specify ³)
Jitter:	±15 ps
DC offset or bias insertion ⁴ :	Optional. Apply DC offset in the range of ±50V (250 mA max) to back panel solder terminal.
Trigger required:	+5 Volts, 50 to 500 ns (TTL)
Connectors:	Out: SMA, In: SMA, Power: Solder terminal
Power required:	+15 Volts, 200 mA
Dimensions:	102 x 152 x 203 mm (4 x 6 x 8")
Temperature range:	+5°C to +40°C

1) For operation at amplitudes of less than 20% of full-scale, best results will be obtained by setting the amplitude near full-scale and using external attenuators on the output.

2) For electronic control (0 to +10V) of amplitude or pulse width, suffix the model number with -EA or -EW.

3) Indicate desired polarity by suffixing model number with -P or -N (i.e. positive or negative).

4) For DC offset option suffix model number with -OS. Avtech Model AVX-T bias tee can also be used to obtain DC offset (<http://www.avtechpulse.com/bias/avx-t>).

CONTROLS

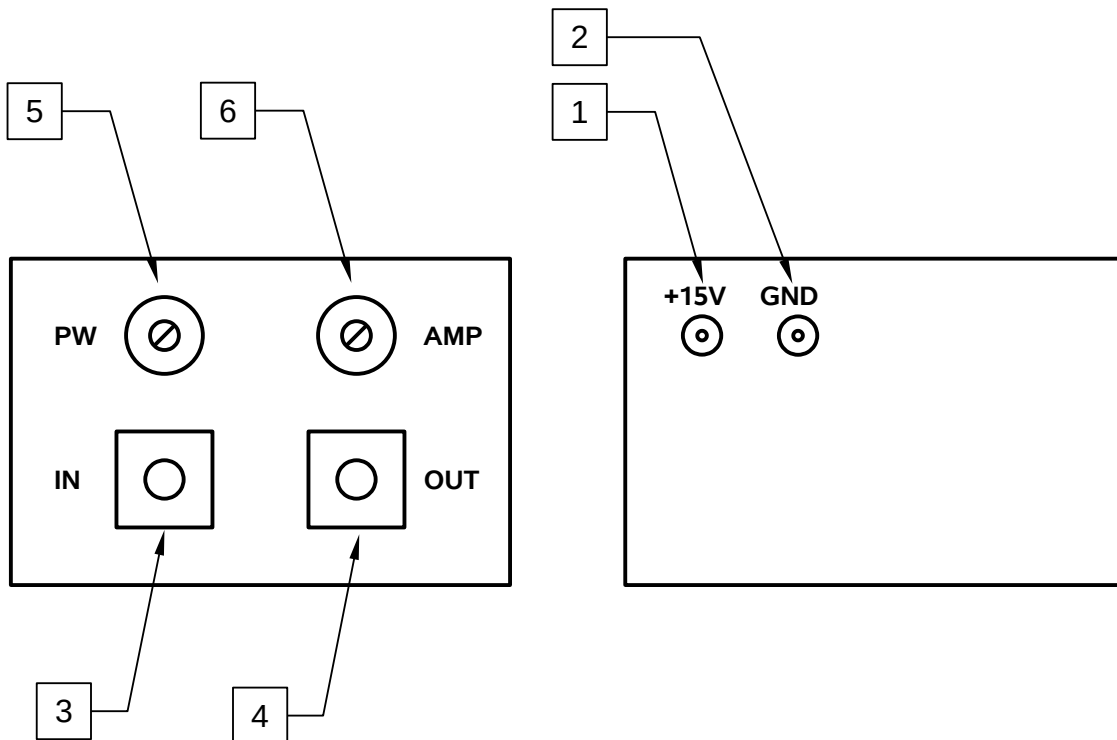

1. +15V POWER Input. Apply +15V prime power to this solder terminal.
2. Ground. Connect this solder terminal to your power supply ground.
3. IN Connector. The module triggers from TTL logic levels applied to this SMA connector. The input impedance of this input is $> 1 \text{ k}\Omega$. Depending on the length of cable attached to this input, and the source driving it, it may be desirable to add a coaxial 50Ω terminator to this input to provide a proper transmission line termination. The Pasternack (www.pasternack.com) PE6026 SMA feed-thru 50Ω terminator is suggested for this purpose.
4. OUT Connector. This is the main output. (This output *requires* a 50Ω load to function properly).
5. PW Control. To control the pulse width of the output, rotate this potentiometer using a small screwdriver. Fully counter-clockwise corresponds to minimum output pulse width, and fully clockwise corresponds to maximum output pulse width.

Units with the -EW option will have a solder terminal to control the pulse width, rather than a screwdriver-adjustable trimpot. The pulse width is then controlled by a 0 to +10V DC voltage applied to the solder terminal.

6. AMP Control. To control the amplitude of the output, rotate this potentiometer using a small screwdriver. Fully counter-clockwise corresponds to minimum output amplitude, and fully clockwise corresponds to maximum output amplitude.

Units with the -EA option will have a solder terminal to control the amplitude, rather than a screwdriver-adjustable trimpot. The amplitude is then controlled by a 0 to +10V DC voltage applied to the solder terminal.

BASIC TEST ARRANGEMENT

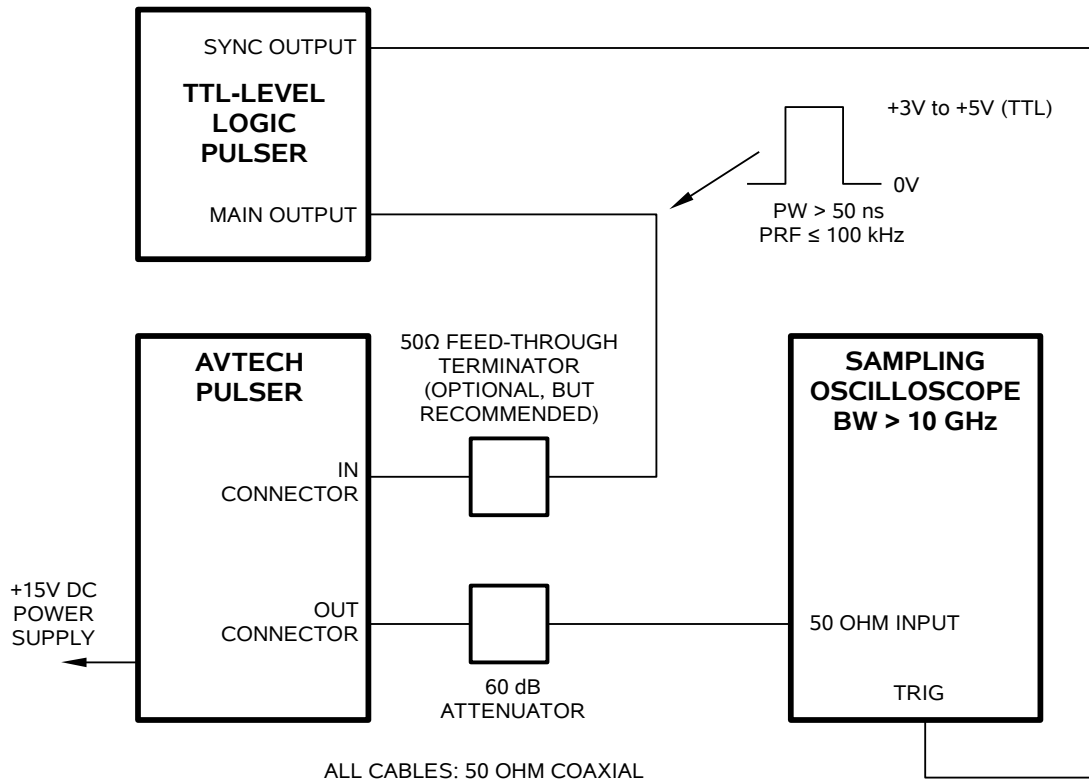

GENERAL OPERATING NOTES

- 1) The bandwidth capability of components and instruments used to display the pulse generator output signal (attenuators, cables, connectors, etc.) should exceed 10 GHz.
- 2) The use of 60 dB attenuator on the output will ensure a peak input signal to the sampling scope of much less than 1 Volt.
- 3) In general, the source pulse generator trigger delay control should be set in the 0.1 to 1.0 μ s range, for proper positioning of the output pulse on the sampling oscilloscope display.
- 4) When testing using a general purpose 50 Ω laboratory pulse generator as the input trigger signal source, the input signal should be applied via a 50 Ω feed-through terminator. This will prevent reflection (and degradation of the input pulse waveform) caused by the high impedance at the IN port.
- 5) The input trigger pulse width should be greater than 50 ns and less than one half of the pulse repetition frequency period. The unit triggers on the leading edge of the

input trigger signal.

- 6) Some properties of the output pulse may change as a function of the amplitude and pulse width settings. For some demanding applications, it may be desirable to use a combination of external attenuators and the amplitude pot to achieve the desired output amplitude.

MINIMIZING WAVEFORM DISTORTIONS

USE 50 OHM TRANSMISSION LINES AND LOADS

Connect the load to the pulse generator with 50Ω transmission lines (e.g. RG-58 or RG-174 cable).

This instrument requires a 50Ω load for proper operation. It will not properly drive a high-impedance load. The output stage will be damaged if it is operated into an open circuit (or any other high impedance). Failures due to improper output loading are not covered by the warranty.

USE LOW-INDUCTANCE LOADS

Lenz's Law predicts that for an inductive voltage spike will be generated when the current through an inductance changes. Specifically, $V_{\text{SPIKE}} = L \times dI_{\text{LOAD}}/dt$, where L is the inductance, I_{LOAD} is the load current change, and t is time. For this reason, it is important to keep any parasitic in the load low. This means keeping wiring short, and using low inductance components. In particular, wire-wound resistors should be avoided.

PREVENTING DAMAGE

The AVI-V-2L may fail if triggered at a PRF greater than 100 kHz.

This unit is designed to operate into a load impedance of 50 Ohms and the output stage will be damaged if it is operated into an open circuit (or any other high impedance). Failures due to improper output loading are not covered by the warranty.

The lifetime of the switching elements in the pulse generator module is proportional to the running time of the instrument. For this reason the prime power to the instrument should be turned off when the instrument is not in use.

PERFORMANCE CHECK SHEET