

INSTRUCTIONS

MODEL AVI-V-HV1-C

0 TO 50 VOLTS, 20 kHz

HIGH SPEED PULSE GENERATOR

WITH 250 ps RISE TIME, 2 ns FALL TIME

SERIAL NUMBER: _____

WARRANTY

Avtech Electrosystems Ltd. warrants products of its manufacture to be free from defects in material and workmanship under conditions of normal use. If, within one year after delivery to the original owner, and after prepaid return by the original owner, this Avtech product is found to be defective, Avtech shall at its option repair or replace said defective item. This warranty does not apply to units which have been disassembled, modified or subjected to conditions exceeding the applicable specifications or ratings. This warranty is the extent of the obligation assumed by Avtech with respect to this product and no other warranty or guarantee is either expressed or implied.

TECHNICAL SUPPORT

Phone: 613-226-5772 or 1-800-265-6681

Fax: 613-226-2802 or 1-800-561-1970

E-mail: info@avtechpulse.com

World Wide Web: <http://www.avtechpulse.com>

TABLE OF CONTENTS

| | |
|--|-----------|
| WARRANTY | 2 |
| TECHNICAL SUPPORT | 2 |
| TABLE OF CONTENTS | 3 |
| INTRODUCTION | 5 |
| AVAILABLE OPTIONS | 5 |
| SPECIFICATIONS | 6 |
| EC DECLARATION OF CONFORMITY | 7 |
| INSTALLATION | 8 |
| VISUAL CHECK | 8 |
| LINE VOLTAGE SELECTION | 8 |
| CONNECTION TO THE POWER SUPPLY | 9 |
| POWER RATINGS | 10 |
| ENVIRONMENTAL CONDITIONS | 10 |
| FUSES | 11 |
| AC FUSE REPLACEMENT | 11 |
| DC FUSE REPLACEMENT | 12 |
| FUSE RATINGS | 12 |
| FRONT PANEL CONTROLS | 13 |
| REAR PANEL CONTROLS | 15 |
| GENERAL INFORMATION | 16 |
| BASIC TEST ARRANGEMENT | 16 |
| BASIC PULSE CONTROL | 16 |
| AMPLITUDE INTERACTION | 18 |
| POLARITY INVERSION | 18 |
| MINIMIZING WAVEFORM DISTORTIONS | 19 |
| USE 50 TRANSMISSION LINES AND LOADS | 19 |
| USE LOW-INDUCTANCE LOADS | 19 |
| PREVENTING DAMAGE | 19 |
| OPTIONS | 20 |
| -OS OPTION | 20 |

| | |
|--------------------------------|-----------|
| -M OPTION | 20 |
| -EA OPTION | 20 |
| -EW OPTION | 20 |
| MECHANICAL INFORMATION | 21 |
| TOP COVER REMOVAL | 21 |
| ELECTROMAGNETIC INTERFERENCE | 21 |
| MAINTENANCE | 21 |
| REGULAR MAINTENANCE | 21 |
| CLEANING | 21 |
| PERFORMANCE CHECK SHEET | 22 |

INTRODUCTION

The AVI-V-HV1-C is a high performance instrument capable of generating up to 50V into 50 Ω loads at repetition rates up to 20 kHz. The output pulse width is variable from 2 to 100 ns, and the sync delay is variable up to ± 500 ns. The rise time is less than 250 ps, and the fall time is 4 ns.

Instruments with the "-P" model suffix can generate 0 to +50V, whereas instruments with the "-N" model suffix can generate 0 to -50V.

Instruments with the "-P-PN" suffix generate 0 to +50V at the main output, and are supplied with an inverting transformer that can be installed on the output to generate a negative signal.

Instruments with the "-N-PN" suffix generate 0 to -50V at the main output, and are supplied with an inverting transformer that can be installed on the output to generate a positive signal.

The output is designed to drive 50 Ω loads. (A 50 Ω load is required for proper operation.) The output is AC-coupled.

This instrument is intended for use in research and development laboratories.

AVAILABLE OPTIONS

The AVI-V-HV1-C is available with several options:

"-OS" Option: an externally generated DC offset can be added to the output.

"-M" Option: a monitor output is provided.

"-EA" Option: the output amplitude can be controlled by an externally generated 0 to +10V analog control voltage.

"-EW" Option: the output pulse width can be controlled by an externally generated 0 to +10V analog control voltage.

"-TR" Option: this option reduces the rise time from 250 ps to 200 ps. The output amplitude of models with this option is fixed (i.e., non-adjustable) at 50V.

SPECIFICATIONS

| | |
|--|---|
| Model: | AVI-V-HV1-C ¹ |
| Amplitude ^{3,4} : (50 Ohm load required) | 0 to 50 Volts, variable (fixed with -TR option ⁵) |
| Rise time: | ≤ 250ps, or 200ps ⁵ |
| Fall time: | ≤ 2 ns |
| Pulse width ⁴ : | 2 to 100 ns |
| Maximum pulse repetition frequency (PRF): | 20 kHz |
| Polarity ⁶ : | Positive or negative or both (specify -P, -N, -P-PN or -N-PN) |
| Propagation delay: | ≤ 250 ns (Ext trig in to pulse out) |
| Jitter: | ±15 ps |
| DC offset or bias insertion ⁷ : | Optional. Apply DC offset in the range of ±50V (250 mA max) to back panel solder terminal. See note 7. |
| Trigger required: | Ext trig mode: +5 Volts, 50 to 500 ns (TTL) |
| Sync delay: | Sync out to pulse out: Variable 0 to 500 ns |
| Sync output: | +2 Volts, 200 ns, will drive 50 Ohm loads |
| Monitor output option ⁸ : | Provides a 20 dB attenuated coincident replica of main output |
| Connectors: | Out: SMA, Trig: BNC, Sync: BNC, Monitor: SMA |
| Power required: | 115/230 Volts (switchable) 50-60 Hz |
| Dimensions: | 100 x 215 x 375 mm (3.9 x 8.5 x 14.8") |

- 1) -C suffix indicates stand-alone lab instrument with internal clock and line powering. No suffix indicates miniature module requiring DC power and external trigger. (See page 112 for additional details of the basic instrument formats).
- 2) -B suffix indicates IEEE-488.2 GPIB and RS-232 control of amplitude, pulse width, PRF and delay (See page 8).
- 3) For operation at amplitudes of less than 10% of full-scale, best results will be obtained by setting the amplitude near full-scale and using external attenuators on the output.
- 4) For electronic control (0 to +10V) of amplitude or pulse width, suffix the model number with -EA or -EW. Electronic control units also include standard front-panel controls. -EA is available -on C and -B units. -EW is available on -C units only.
- 5) For 200 ps rise time option, add suffix -TR. Output amplitude fixed at 50 Volts for -TR option units. For HV1 models only.
- 6) Indicate desired polarity by suffixing model number with -P or -N (i.e. positive or negative) or -P-PN or -N-PN for dual polarity option where the suffix preceding -PN indicates the polarity at the mainframe output port. (Not available on modules.)
- 7) For DC offset option suffix model number with -OS. Avtech Model AVX-T bias tee can also be used to obtain DC offset.
- 8) For monitor option add suffix -M. (Not available on modules.)

EC DECLARATION OF CONFORMITY

We

Avtech Electrosystems Ltd.
P.O. Box 5120, LCD Merivale
Ottawa, Ontario
Canada K2C 3H4

declare that this pulse generator meets the intent of Directive 89/336/EEC for Electromagnetic Compatibility. Compliance pertains to the following specifications as listed in the official Journal of the European Communities:

EN 50081-1 Emission

EN 50082-1 Immunity

and that this pulse generator meets the intent of the Low Voltage Directive 72/23/EEC as amended by 93/68/EEC. Compliance pertains to the following specifications as listed in the official Journal of the European Communities:

EN 61010-1:2001 Safety requirements for electrical equipment for measurement, control, and laboratory use



INSTALLATION

VISUAL CHECK

After unpacking the instrument, examine to ensure that it has not been damaged in shipment. Visually inspect all connectors, knobs, and handles. Confirm that a power cord is with the instrument. If the instrument has been damaged, file a claim immediately with the company that transported the instrument.

LINE VOLTAGE SELECTION

Examine the rear of the instrument. There will be a power-entry module consisting of a male power receptacle, the main power switch, and a fuse holder / voltage selector. Confirm that the voltage selector is in the correct orientation. For AC line voltages of 115V \pm 10%, 50 - 60 Hz, the power selector card should be installed so that the "115" marking is visible from the rear of the instrument. For AC line voltages of 230V \pm 10%, 50 - 60 Hz, the power selector card should be installed so that the "230" marking is visible from the rear of the instrument. The two possible settings are shown below:

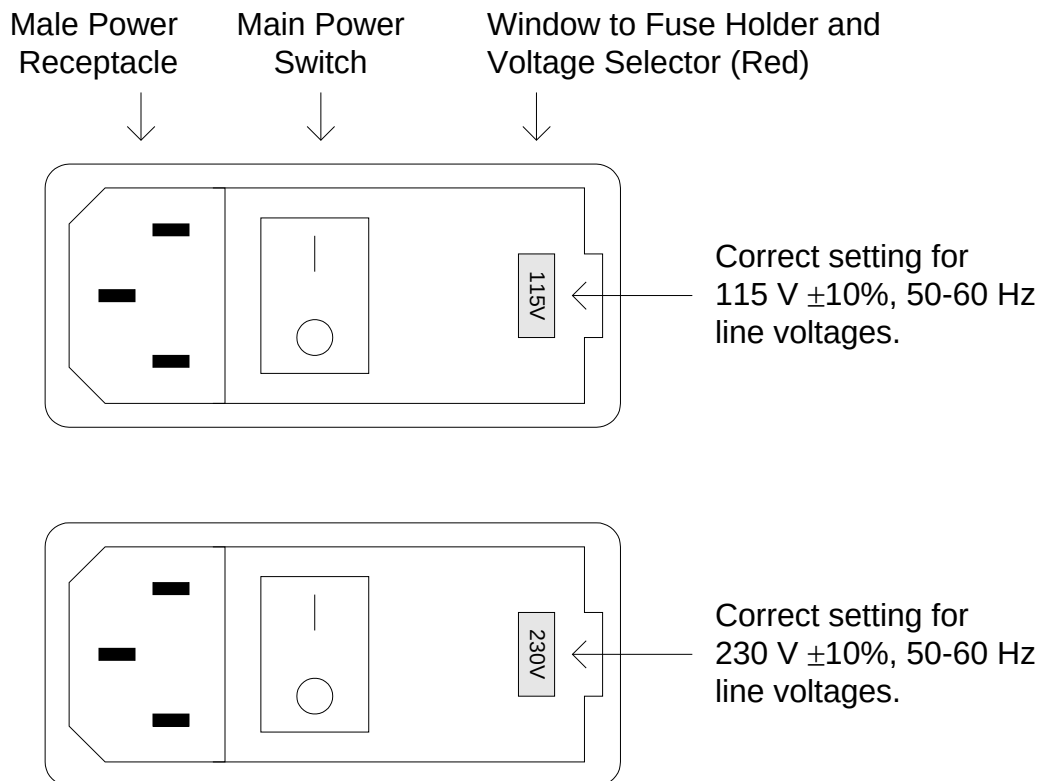

If the voltage selector is not set for to proper voltage, use a small flat-head screwdriver to pry open the voltage selector panel, as shown below:

Fuse Holder and Voltage Selector Panel.
The panel is hinged on the left. Pry open
with a flat screwdriver from the right.

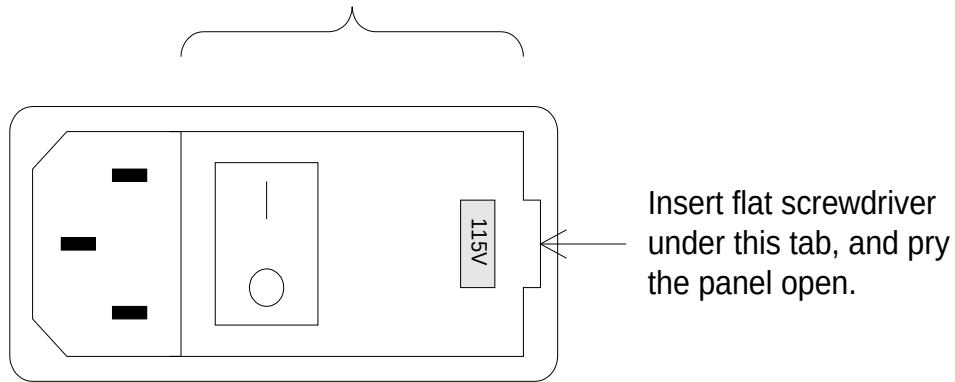

Fuse Holder and Voltage Selector.
After opening the panel, the red plastic
fuse holder and voltage selector will be
visible.

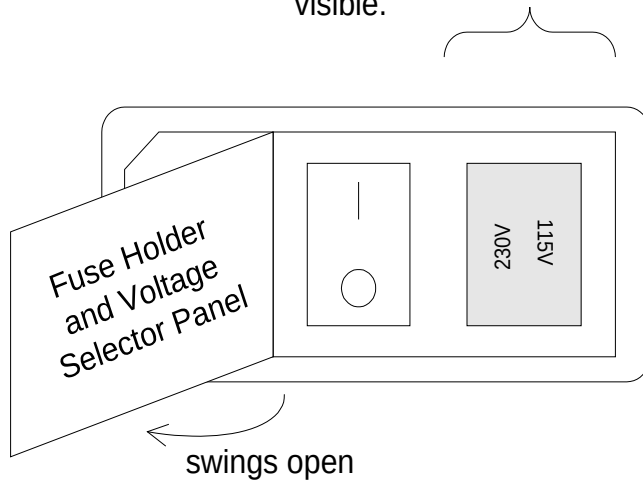

Once the panel is open, the red fuse holder / voltage selector should be visible. To change the voltage setting, pull out the red fuse holder / voltage selector and rotate it so that the proper voltage marking will shown through the panel window. Re-install the red fuse holder / voltage selector, and close the panel.

CONNECTION TO THE POWER SUPPLY

An IEC-320 three-pronged recessed male socket is provided on the back panel for AC power connection to the instrument. One end of the detachable power cord that is supplied with the instrument plugs into this socket. The other end of the detachable

power cord plugs into the local mains supply. Use only the cable supplied with the instrument. The mains supply must be earthed, and the cable used to connect the instrument to the mains supply must provide an earth connection. (The supplied cable does this.)

POWER RATINGS

This instrument is intended to operate from 115 / 230 V \pm 10%, 50-60 Hz. The maximum power consumption is 28W. This instrument is an "Installation Category II" instrument, intended for operation from a normal single-phase supply.

ENVIRONMENTAL CONDITIONS

This instrument is intended for use under the following conditions:

- a) indoor use;
- b) altitude up to 2 000 m;
- c) temperature 5 °C to 40 °C;
- d) maximum relative humidity 80 % for temperatures up to 31 °C decreasing linearly to 50 % relative humidity at 40 °C;
- e) Mains supply voltage fluctuations up to \pm 10 % of the nominal voltage;
- f) no pollution or only dry, non-conductive pollution.

FUSES

This instrument contains four fuses. All are accessible from the rear-panel. Two protect the AC prime power input, and two protect the internal DC power supplies. The locations of the fuses on the rear panel are shown in the figure below:

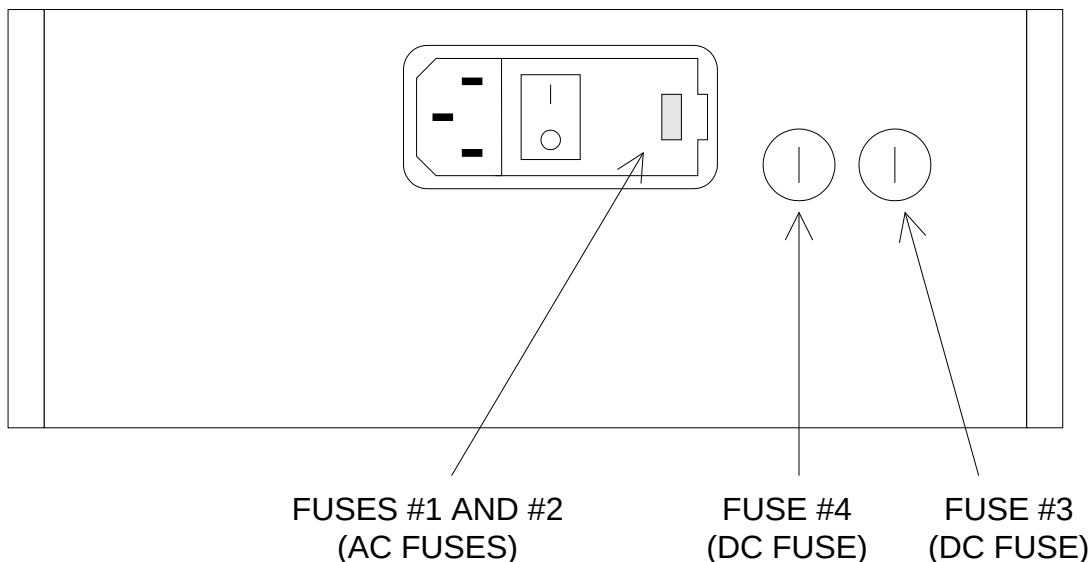

AC FUSE REPLACEMENT

The red fuse holder / voltage selector described in the previous section contains two fuses. One protects the AC “Line” input, and one protects the AC “Neutral” input. To replace the AC fuses, pull out the red fuse holder / voltage selector (as described in the previous section). The location of the two identical 5 mm x 20 mm fuses is shown below:

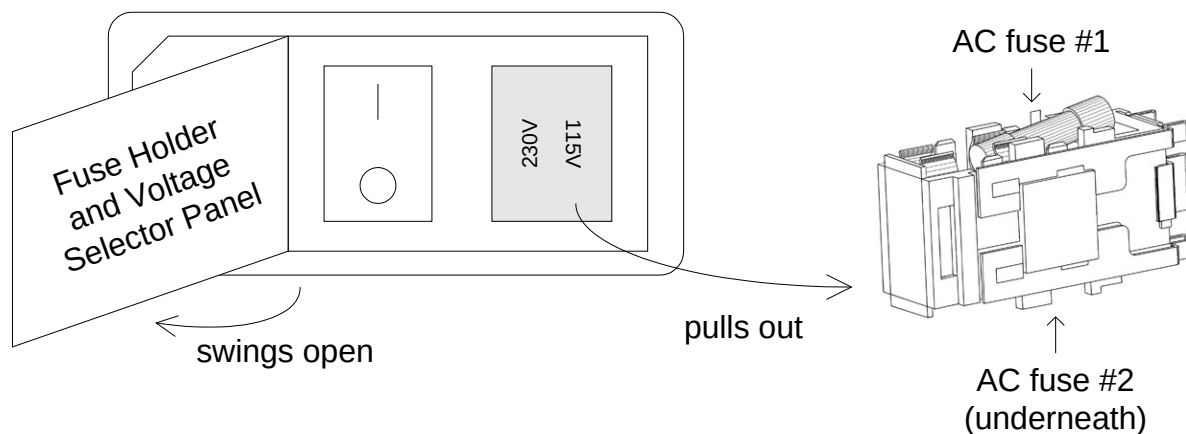

DC FUSE REPLACEMENT

The DC fuses may be replaced by inserting the tip of a flat-head screwdriver into the fuseholder slot, and rotating the slot counter-clockwise. The fuse and its carrier will then pop out.

FUSE RATINGS

The following table lists the required fuses:

| Fuse | Mains Voltage | Rating | Case Size | Manufacturer's Part Number (Wickmann) | Distributor's Part Number (Digi-Key) |
|---------|---------------|--------------------------|-----------|---------------------------------------|--------------------------------------|
| #1 (AC) | 115 V | 0.25A, 250V, Time-Delay | 5 x 20 mm | 1950250000 | WK5035-ND |
| | 230 V | 0.125A, 250V, Time-Delay | 5 x 20 mm | 1950125000 | WK5028-ND |
| #2 (AC) | 115 V | 0.25A, 250V, Time-Delay | 5 x 20 mm | 1950250000 | WK5035-ND |
| | 230 V | 0.125A, 250V, Time-Delay | 5 x 20 mm | 1950125000 | WK5028-ND |
| #3 (DC) | 115/230V | 0.5A, 250V, Time-Delay | 5 x 20 mm | 1950500000 | WK5041-ND |
| #4 (DC) | 115/230V | Not Used* | 5 x 20 mm | 1950500000 | WK5041-ND |

* A spare fuse, identical to fuse #3, is installed in this position. It is not electrically active.

The fuse manufacturer is Wickmann (<http://www.wickmann.com/>).

Replacement fuses may be easily obtained from Digi-Key (<http://www.digikey.com/>) and other distributors.

FRONT PANEL CONTROLS

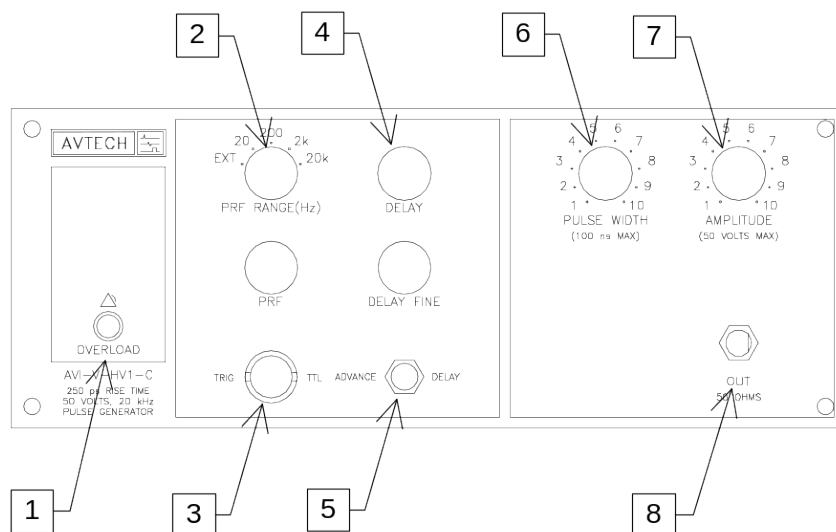

1. OVERLOAD Indicator. When the instrument is powered, this indicator is normally green, indicating normal operation. If this indicator is yellow, an internal automatic overload protection circuit has been tripped. If the unit is overloaded (by operating at an exceedingly high duty cycle or by operating into a very low impedance), the protective circuit will disable the output of the instrument and turn the indicator light yellow. The light will stay yellow (i.e. output disabled) for about 5 seconds after which the instrument will attempt to re-enable the output (i.e. light green) for about 1 second. If the overload condition persists, the output will be disabled again (i.e. light yellow) for another 5 seconds. If the overload condition has been removed, the instrument will resume normal operation.

This overload indicator may flash yellow briefly at start-up. This is not a cause for concern.

2. PRF Range Switch. This switch sets the pulse repetition frequency (PRF) range of the internal oscillator. The marked value of each position is the upper limit of the 10:1 range, approximately. The vernier dial directly below the switch varies the PRF within the set range.

If this switch is set to the "EXT" position, the instrument is triggered by a signal applied to the TRIG connector, rather than by the internal oscillator.

3. TRIG Connector. When the PRF Range Switch is set to "EXT", the instrument is triggered by a TTL pulse applied to this connector. The pulse must be at least 50 ns wide.

When the PRF Range Switch is set to one of the four internal oscillator ranges, this connector is an output, which supplies a 2V, 200 ns wide pulse for each trigger event. This output may be used to trigger oscilloscopes or other equipment.

4. Delay Controls. When the PRF Range Switch is set to one of the four internal oscillator ranges, the main output is advanced or delayed relative to the TRIG output pulse (item 3). The delay is variable up to 500 ns, approximately, using the DELAY and DELAY FINE dials.
5. Advance/Delay Switch. When the PRF Range Switch is set to one of the four internal oscillator ranges, this switch determines whether the TRIG output precedes the main output (ADVANCE mode), or whether the TRIG output occur after the main output (DELAY mode).
6. Pulse Width Control. This dial controls the pulse width.
7. Amplitude Control. This dial controls the pulse amplitude.
8. OUT Connector. This is the main output. (This output *requires* a 50 Ω load to function properly).

REAR PANEL CONTROLS

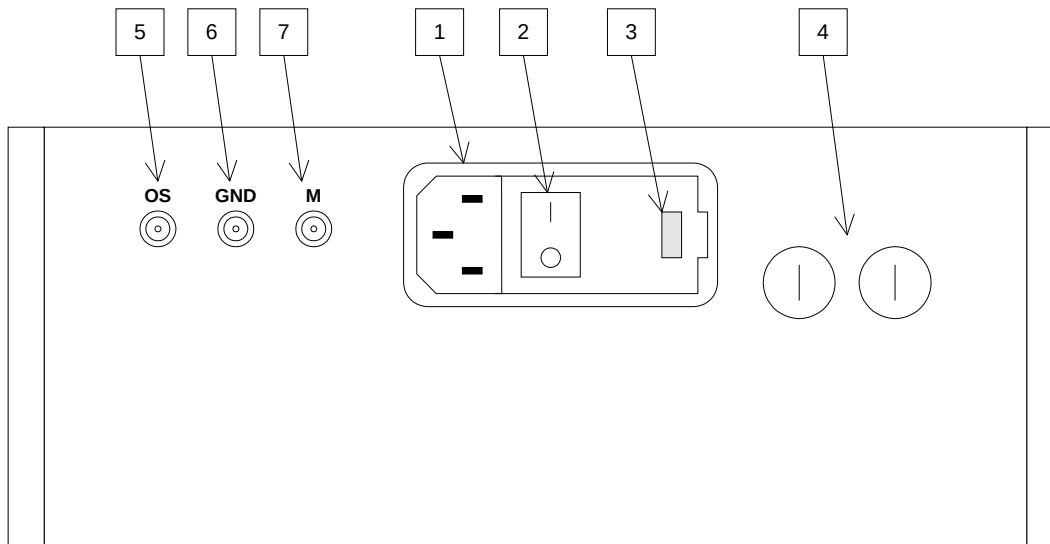

1. AC POWER INPUT. An IEC-320 three-pronged recessed male socket is provided on the back panel for AC power connection to the instrument. One end of the detachable power cord that is supplied with the instrument plugs into this socket.
2. POWER SWITCH. This is the main power switch. The instrument should be positioned so that the switch is accessible.
3. FUSE HOLDER / VOLTAGE SELECTOR. This red plastic module must be installed so that the marked voltage equals the AC line voltage. This module also contains two fuses that protect the AC inputs. Please see the “LINE VOLTAGE SELECTION” and “FUSES” sections of this manual for more information.
4. DC FUSES. These two fuses protect the internal DC power supplies. Please see the “FUSES” sections of this manual for more information.
5. OS INPUT CONNECTOR. (Present on units with -OS option only.) A DC offset in the range of $\pm 50\text{V}$ (250 mA max) may be applied to this solder terminal. The DC offset will appear on the output. When this feature is not used, the OS input should be connected to ground (using the adjacent GND connector). This is especially important when driving loads containing a diode.
6. GND CONNECTOR. (Present on units with -OS option only.) This solder terminal is connected to ground. It may be used to ground the OS input connector.
7. M OUTPUT CONNECTOR. (Present on units with -M option only.) This SMA connector output provides a 20 dB attenuated coincident replica of main output, for monitoring purposes.

GENERAL INFORMATION

BASIC TEST ARRANGEMENT

The AVI-V-HV1-C should be tested with a sampling oscilloscope with a bandwidth of at least 5 GHz to properly observe the high-speed waveform. A typical test arrangement is shown below:

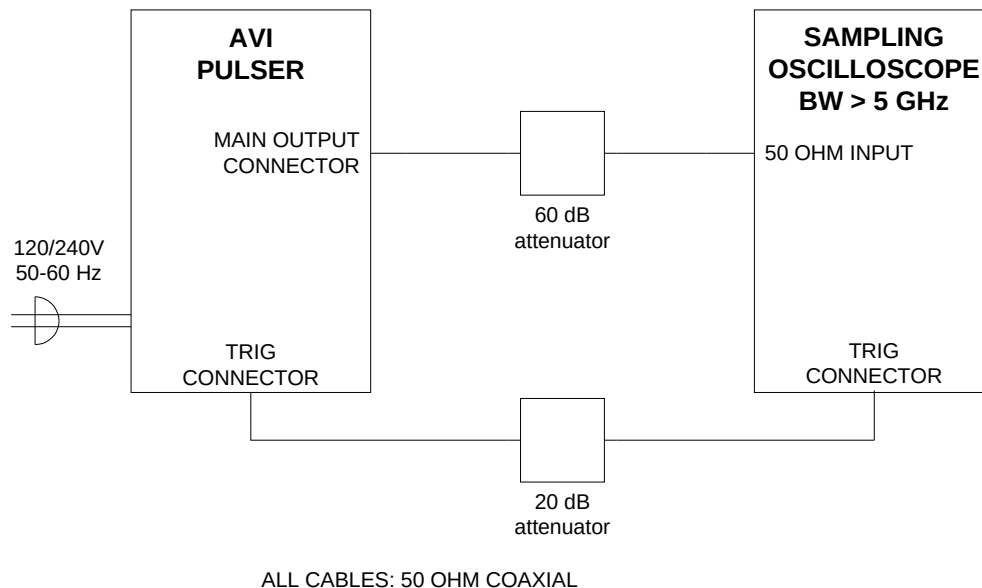

The attenuators are required to prevent damage to the sampling oscilloscope. A 50 or 60 dB attenuator with sufficient voltage rating should be used on the main output.

BASIC PULSE CONTROL

This instrument can be triggered by its own internal clock or by an external TTL trigger signal. When triggered internally, two mainframe output channels respond to the trigger: OUT and SYNC.

- OUT. This is the main output. The maximum output voltage is 50V.
- TRIG. The TRIG pulse is a fixed-width TTL-level reference pulse used to trigger oscilloscopes or other measurement systems.

When the ADVANCE/DELAY switch is set to "ADVANCE", the TRIG output precedes the main output. These pulses are illustrated below:

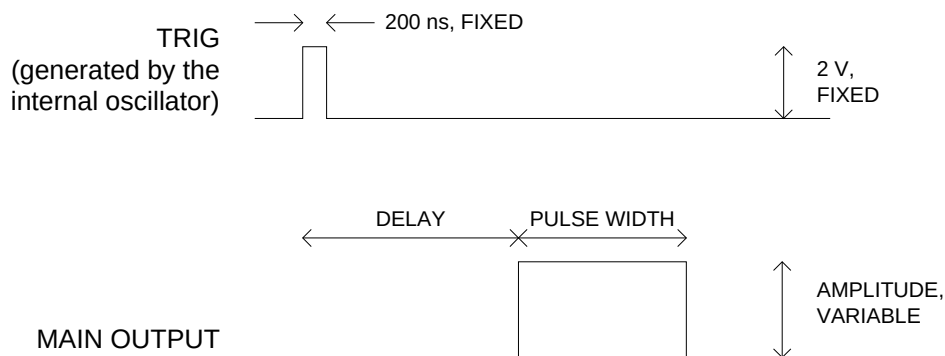
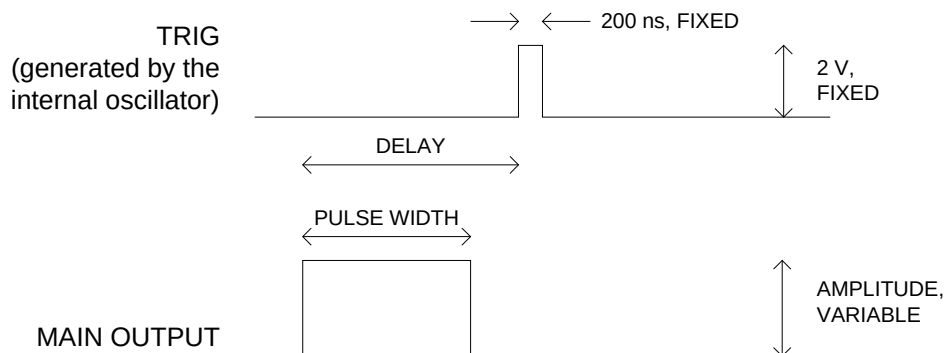
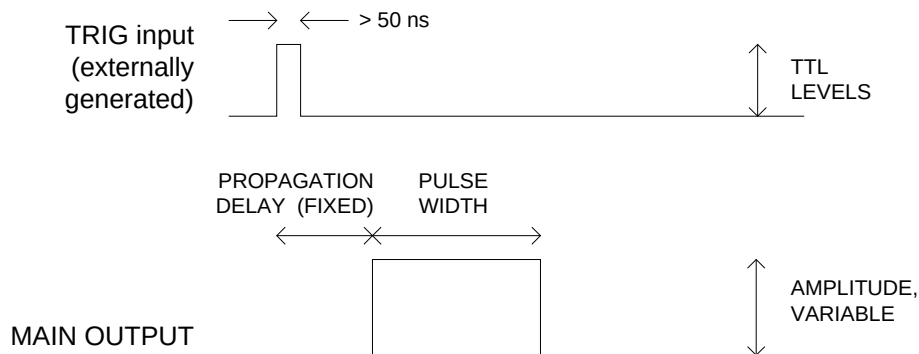

Figure A

When the ADVANCE/DELAY switch is set to "DELAY", the TRIG output occurs after the main output. This illustrated below:



When triggered externally, the TRIG connector acts as an input. The delay controls do not function in this mode. Figure C illustrates this mode:



AMPLITUDE INTERACTION

Some properties of the output pulse may change as a function of the amplitude setting. For some demanding applications, it may be desirable to use a combination of external attenuators and the amplitude pot to achieve the desired output amplitude.

POLARITY INVERSION

Instruments with the "-P-PN" suffix generate 0 to +50V at the main output, and are supplied with an AVX-3 inverting transformer that can be installed on the mainframe output. A negative pulse is then obtained at the out port of the AVX-3 module.

Instruments with the "-N-PN" suffix generate 0 to -50V at the main output, and are supplied with an AVX-3 inverting transformer that can be installed on the mainframe output. A positive pulse is then obtained at the out port of the AVX-3 module.

When using the transformer with dual-polarity models with the "-OS" option, the external offset must be added to the DC terminal of the inverting transformer. Do not apply the offset to the rear-panel offset terminal on the mainframe (if present).

MINIMIZING WAVEFORM DISTORTIONS

USE 50Ω TRANSMISSION LINES AND LOADS

Connect the load to the pulse generator with 50Ω transmission lines (e.g. RG-58 or RG-174 cable).

This instrument requires a 50Ω load for proper operation. It will not properly drive a high-impedance load. The output stage will be damaged if it is operated into an open circuit (or any other high impedance). Failures due to improper output loading are not covered by the warranty.

USE LOW-INDUCTANCE LOADS

Lenz's Law predicts that for an inductive voltage spike will be generated when the current through an inductance changes. Specifically, $V_{\text{SPIKE}} = L \times di_{\text{LOAD}}/dt$, where L is the inductance, i_{LOAD} is the load current change, and t is time. For this reason, it is important to keep any parasitic in the load low. This means keeping wiring short, and using low inductance components. In particular, wire-wound resistors should be avoided.

PREVENTING DAMAGE

The AVI-V-HV1-C may fail if triggered at a PRF greater than 20 kHz.

This unit is designed to operate into a load impedance of 50 Ohms and the output stage will be damaged if it is operated into an open circuit (or any other high impedance). Failures due to improper output loading are not covered by the warranty.

The lifetime of the switching elements in the pulse generator module is proportional to the running time of the instrument. For this reason the prime power to the instrument should be turned off when the instrument is not in use.

OPTIONS

The AVI-V-HV1-C is available with these options:

-OS OPTION

This option allows an externally generated DC offset to be added to the output. The desired DC offset is applied to the back panel OS terminal, which is connected to the output centre conductor through a high-quality RF inductor. Do not exceed 50V, 250 mA.

When using the transformer with dual-polarity models with the “-OS” option, the external offset must be added to the DC terminal of the inverting transformer. Do not apply the offset to the rear-panel offset terminal on the mainframe (if present).

-M OPTION

This option provides a monitor output, which is an attenuated replica of the main output. The monitor is connected to the main output through a 470 Ohm resistor, which results in an attenuation of approximately 20 dB (i.e., $\times 10$) when the monitor output is terminated with a 50 Ohm load.

For models with the “-OS” option, the monitor output does not include the effect of the added offset.

The monitor output should be terminated with a 50 Ohm load.

-EA OPTION

To control the output amplitude with an external voltage, set the rear-panel switch to the “EXT” position and apply 0 to +10V to connector A ($R_{IN} \geq 10k\Omega$).

-EW OPTION

To control the output pulse width with an external voltage, set the rear-panel switch to the “EXT” position and apply 0 to +10V to connector W ($R_{IN} \geq 10k\Omega$).

MECHANICAL INFORMATION

TOP COVER REMOVAL

If necessary, the interior of the instrument may be accessed by removing the four Phillips screws on the top panel. With the four screws removed, the top cover may be slid back (and off).

Always disconnect the power cord before opening the instrument.

There are no user-adjustable internal circuits. For repairs other than fuse replacement, please contact Avtech (info@avtechpulse.com) to arrange for the instrument to be returned to the factory for repair.

ELECTROMAGNETIC INTERFERENCE

To prevent electromagnetic interference with other equipment, all used outputs should be connected to shielded 50 Ω loads using shielded 50 Ω coaxial cables. Unused outputs should be terminated with shielded 50 Ω BNC terminators or with shielded BNC dust caps, to prevent unintentional electromagnetic radiation. All cords and cables should be less than 3m in length.

MAINTENANCE

REGULAR MAINTENANCE

This instrument does not require any regular maintenance.

On occasion, one or more of the four rear-panel fuses may require replacement. All fuses can be accessed from the rear panel. See the "FUSES" section for details.

CLEANING

If desired, the interior of the instrument may be cleaned using compressed air to dislodge any accumulated dust. (See the "TOP COVER REMOVAL" section for instructions on accessing the interior.) No other cleaning is recommended.

PERFORMANCE CHECK SHEET