

INSTRUCTIONS

MODEL AVL-2-C PULSE GENERATOR

S.N.:

WARRANTY

Avtech Electrosystems Ltd. warrants products of its manufacture to be free from defects in material and workmanship under conditions of normal use. If, within one year after delivery to the original owner, and after prepaid return by the original owner, this Avtech product is found to be defective, Avtech shall at its option repair or replace said defective item. This warranty does not apply to units which have been disassembled, modified or subjected to conditions exceeding the applicable specifications or ratings. This warranty is the extent of the obligation assumed by Avtech with respect to this product and no other warranty or guarantee is either expressed or implied.

TECHNICAL SUPPORT

Phone: 613-226-5772 or 1-800-265-6681

Fax: 613-226-2802 or 1-800-561-1970

E-mail: info@avtechpulse.com

World Wide Web: <http://www.avtechpulse.com>

TABLE OF CONTENTS

WARRANTY.....	2
TABLE OF CONTENTS.....	4
FIG. 1: PULSE GENERATOR TEST ARRANGEMENT.....	5
GENERAL OPERATING INSTRUCTIONS.....	6
FIG. 2: FRONT PANEL CONTROLS.....	8
FRONT PANEL CONTROLS.....	9
FIG. 3: BACK PANEL CONTROLS.....	11
BACK PANEL CONTROLS.....	12
POWER SUPPLY AND FUSE REPLACEMENT.....	13
PERFORMANCE CHECK SHEET.....	15

FIG. 1: PULSE GENERATOR TEST ARRANGEMENT

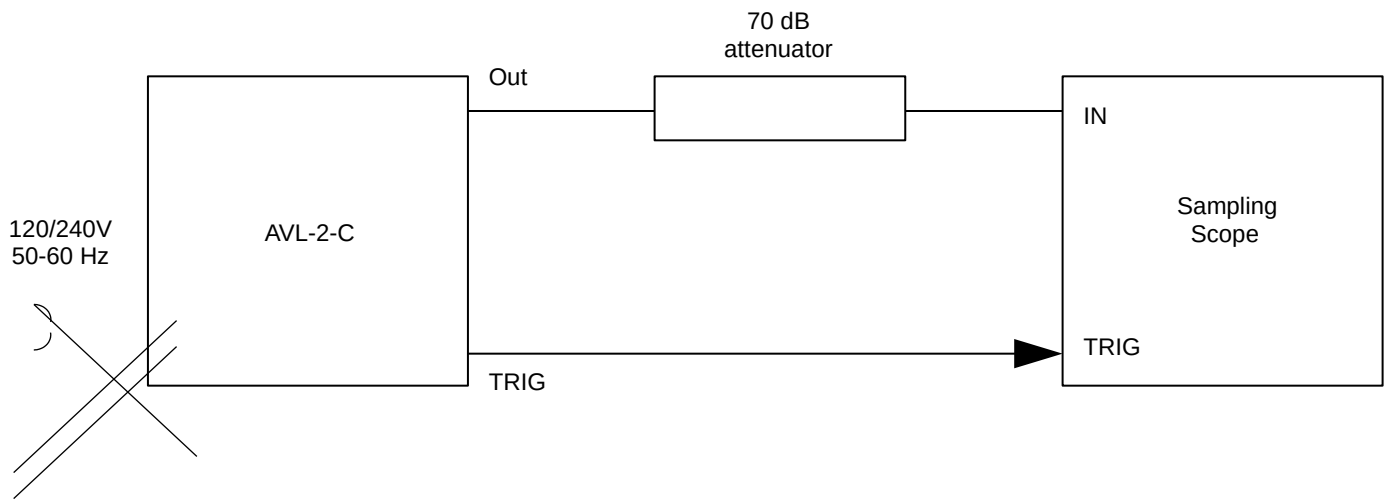

GENERAL OPERATING INSTRUCTIONS

- 1) The bandwidth capability of components and instruments used to display the pulse generator output signal (attenuators, cables, connectors, etc.) should exceed one gigahertz.
- 2) The use of 70 dB attenuator at the sampling scope vertical input channel will insure a peak input signal to the sampling scope of less than one Volt. WARNING: Model AVL-2-C may provide a peak output power in excess of 2.8 KW. The peak power rating of the attenuator must exceed this limit.
- 3) The TRIG output channel provides TTL level signals (+3 Volts, 200 ns). The TRIG output precedes the main output when the front panel ADVANCE-DELAY switch is in the ADVANCE position. The TRIG output lags the main output when the switch is in the DELAY position.
- 4) To obtain a stable output display the PRF controls on the front panel should be set mid-range while the PRF switch may be in either range (but not in the EXT position). The front panel DELAY controls and the scope triggering controls are then adjusted to obtain a stable output. The scope may then be used to set the desired PRF by rotating the PRF controls.
- 5) The output pulse width is controlled by means of the front panel one-turn PW control. The control should initially be set maximum clockwise and the pulse width adjusted using an oscilloscope.
- 6) The output pulse amplitude is controlled by means of the front panel one-turn AMP control.
- 7) To voltage control the output amplitude, set the rear panel switch in the EXT position and apply 0 to +10V to connector A (RIN > 10K). (EA option).
- 8) To DC offset the output pulse connect a DC power supply set to required DC offset value to the back panel terminals marked O.S. The maximum attainable DC offset voltage is ± 50 Volts, ± 200 mA (option).

- 9) An external clock may be used to control the output PRF of the AVL unit by setting the front panel PRF range switch in the EXT position and applying a 50 ns (or wider) TTL level pulse to the TRIG BNC connector input. For operation in this mode, the scope time base must also be triggered by the external clock. The propagation delay time in the externally triggered mode is about 350 ns.
WARNING: Model AVL-2 may fail if triggered at a PRF greater than 5 kHz.
- 10) Model AVL-2 can withstand an infinite VSWR on the output port but is intended for operation with 50 Ohm loads.
- 11) NOTE: The lifetime of the switching elements in the pulse generator module is proportional to the running time of the instrument. For this reason the prime power to the instrument should be turned off when the instrument is not in use.
- 12) MONITOR OUT M. Provides an attenuated (x10) coincident replica of the main positive output pulse to 50-Ohms. (option).
- 13) The unit can be converted from 120 to 240V 50-60 Hz operation by adjusting the voltage selector card in the rear panel fused voltage selector-cable connector assembly.
- 14) For additional assistance:

Tel: (613) 226-5772
Fax: (613) 226-2802
Email: info@avtechpulse.com

FIG. 2: FRONT PANEL CONTROLS

FRONT PANEL CONTROLS

- (1) **ON-OFF Switch.** Applies basic prime power to all stages.
- (2) **PRF Control.** With this range switch in the 5, 50, 500 or 5K positions, the pulse repetition frequency (PRF) of the instrument is controlled by the internal clock oscillator, which in turn is controlled by the PRF range switch and fine control.

With the range switch in the EXT position, the instrument requires a 50 ns (or wider) TTL level pulse applied at the TRIG input in order to trigger the output stages.

- (3) **DELAY Control.** These controls vary the relative delay between reference output pulse provided at the TRIG output (4) and the main output (6). This delay is variable over the range of 0 to about 500 ns. Coarse and fine controls are provided. If the Advance/Delay switch (5) is set to "ADVANCE", the reference output on the TRIG output (4) precedes the main output (6). If the Advance/Delay switch (5) is set to "DELAY", the reference output on the TRIG output (4) lags the main output (6).

The delay is not adjustable when triggering externally.

- (4) **TRIG Output.** This connector has two functions. When triggered internally, this output provides a reference signal that can be used to trigger an oscilloscope scope time base. The output is a +3V, 200 ns (approx.) pulse capable of driving a 50-Ohm load. Set the scope to trigger on the positive edge.

When triggered externally, (i.e., the PRF range switch is in the EXT position), the external TTL-level trigger signal is applied at this point.

- (5) **ADVANCE/DELAY SWITCH.** This switch determines whether the reference output pulse on the TRIG connector (4) occurs in before the main output pulse (ADVANCE mode), or whether the reference pulse occurs after the main output pulse (DELAY mode). This switch is only useful when triggering internally.
- (6) **OUT.** This connector provides the main output pulse. The output is designed to drive 50-Ohm loads.
- (7) **PULSE WIDTH.** A one-turn control which varies the output pulse width.

- (8) AMPLITUDE. A one-turn control which varies the output pulse amplitude.

FIG. 3: BACK PANEL CONTROLS

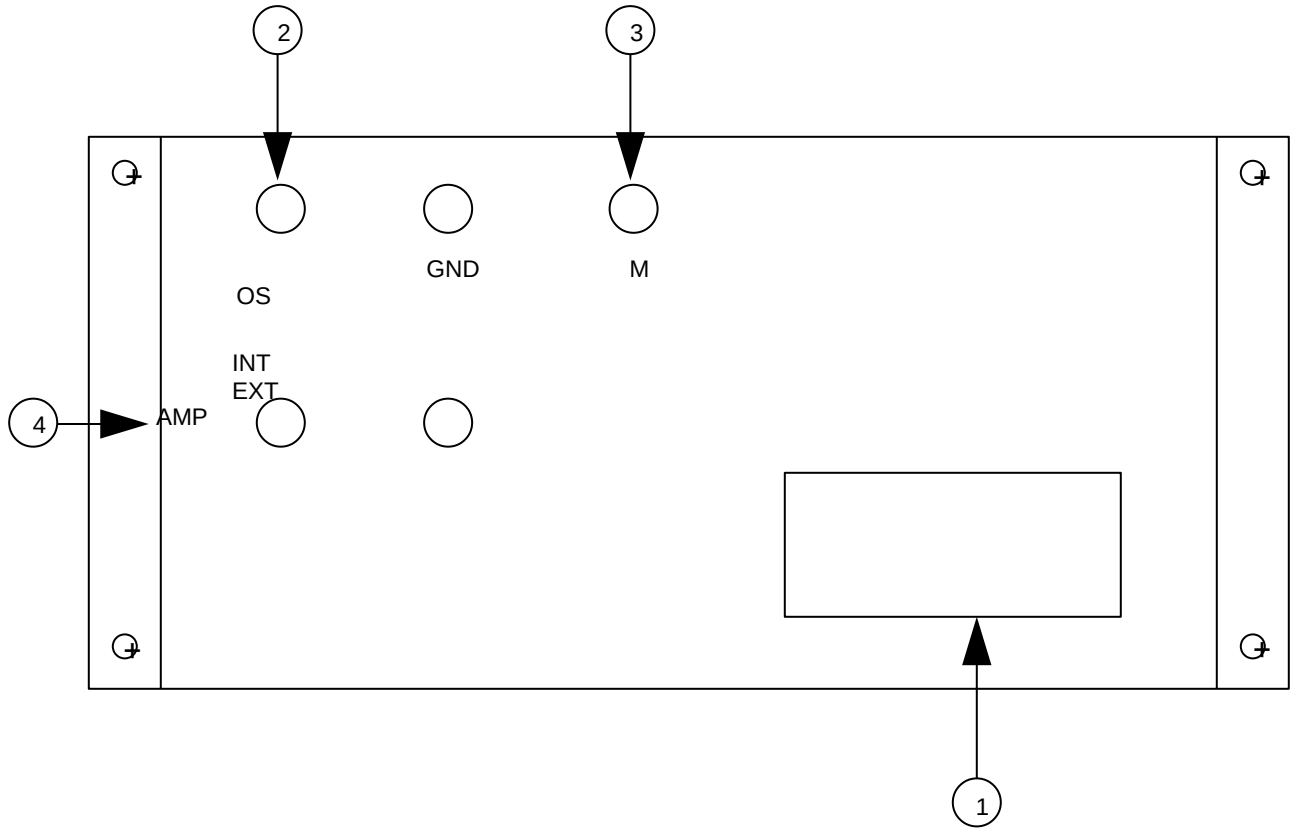

BACK PANEL CONTROLS

- (1) **FUSED CONNECTOR, VOLTAGE SELECTOR.** The detachable power cord is connected at this point. In addition, the removable cord is adjusted to select the desired input operating voltage. The unit also contains the main power fuse.

For AC line voltages of 110-120V, the power selector card should be installed so that the "120" marking is visible from the rear of the instrument.

For AC line voltages of 220-240V, the power selector card should be installed so that the "240" marking is visible from the rear of the instrument.

If it is not set for the proper voltage, remove the fuse and then grasp the card with a pair of pliers and remove it. Rotate horizontally through 180 degrees. Reinstall the card and the correct fuse.

In the 120V setting, a 0.5A slow blow fuse is required. In the 240V setting, a 0.25A slow blow fuse is required.

- (2) **DC OFFSET Input.** To DC offset the output pulse, connect a DC power supply set to the desired offset value to these terminals. The maximum allowable DC offset voltage is ± 50 Volts, ± 200 mA (-OS option).
- (3) **MONITOR Output.** The back monitor output provides an attenuated replica (20dB down) of the output. The monitor output is designed to operate into a 50 Ohm load. (Option).
- (4) To voltage control the output amplitude, set the switch in the EXT position and apply 0 to +10V to connector A (RIN >10K). (EA option).

1. Remove the top cover, by removing the four Phillips screws on the top cover and then sliding the cover back and off.
2. Locate the two "Power OK" LEDs on the power supply circuit board, as illustrated above.
3. Turn on the instrument.
4. Observe the "Power OK" LEDs. If the fuses are not blown, the two LEDs will be lit (bright red). If one of the LEDs is not lit, the fuse next to it has blown.
5. Turn off the instrument.
6. If a fuse is blown, use needle-nose pliers to remove the blown fuse from its surface-mount holder.
7. Replace the fuse. (Spare 1 Amp and 0.5 Amp fuses are provided on the circuit board. They may be transferred to the active fuse locations using needle-nose pliers.)

PERFORMANCE CHECK SHEET