

INSTRUCTIONS

MODEL AVL-AV-1-B-W-KPMA

0 TO ± 100 VOLTS, 3 - 400 ns PULSE WIDTH

HIGH PERFORMANCE PULSE GENERATOR
WITH IEEE 488.2 AND RS-232 CONTROL

SERIAL NUMBER: _____

WARRANTY

Avtech Electrosystems Ltd. warrants products of its manufacture to be free from defects in material and workmanship under conditions of normal use. If, within one year after delivery to the original owner, and after prepaid return by the original owner, this Avtech product is found to be defective, Avtech shall at its option repair or replace said defective item. This warranty does not apply to units which have been disassembled, modified or subjected to conditions exceeding the applicable specifications or ratings. This warranty is the extent of the obligation assumed by Avtech with respect to this product and no other warranty or guarantee is either expressed or implied.

TECHNICAL SUPPORT

Phone: 613-226-5772 or 1-800-265-6681

Fax: 613-226-2802 or 1-800-561-1970

E-mail: info@avtechpulse.com

World Wide Web: <http://www.avtechpulse.com>

TABLE OF CONTENTS

WARRANTY	2
TECHNICAL SUPPORT	2
TABLE OF CONTENTS	3
INTRODUCTION	4
SPECIFICATIONS	5
INSTALLATION	6
VISUAL CHECK	6
PLUGGING IN THE INSTRUMENT	6
LABVIEW DRIVERS	7
FRONT PANEL CONTROLS	8
REAR PANEL CONTROLS	10
GENERAL INFORMATION	12
BASIC PULSE CONTROL	12
TRIGGER MODES	14
GATING MODES	15
TOP COVER REMOVAL	15
ELECTROMAGNETIC INTERFERENCE	15
REPLACEMENT CABLES	15
PROTECTING YOUR INSTRUMENT	16
TURN OFF INSTRUMENT WHEN NOT IN USE	16
TURN INSTRUMENT OFF WHEN CHANGING PULSE WIDTH CABLES	16
DO NOT EXCEED 5 kHz	16
USE A 50 Ω LOAD	16
OPERATIONAL CHECK	17
PROGRAMMING YOUR PULSE GENERATOR	21
KEY PROGRAMMING COMMANDS	21
ALL PROGRAMMING COMMANDS	22
PERFORMANCE CHECKSHEET	24

INTRODUCTION

The AVL-AV-1-B-W-KPMA is a high performance, GPIB and RS232-equipped instrument capable of generating 100V into 50 Ω loads at repetition rates up to 5 kHz.

This instrument has two operating modes, which depend on the type of cable installed between the rear-panel “A” and “B” SMA connectors.

When the supplied 100-foot coaxial cable is installed between the rear-panel “A” and “B” SMA connectors, the pulse width may be varied from 7 ns to 400 ns, approximately. In this mode, the rise time is < 2 ns, and the fall time is < 5 ns. The pulse width controls are calibrated for use in this mode.

When the supplied six-inch coaxial cable is installed between the rear-panel “A” and “B” SMA connectors, the pulse width may be varied from 3 ns to 100 ns, approximately. In this mode, the rise time is < 1 ns, and the fall time is < 2 ns. The pulse width controls are not calibrated for use in this mode. To obtain actual outputs of 3-100 ns in pulse width, the front-panel pulse width controls must be set to 140-240 ns, approximately.

The six-inch cable is a standard RG174A/U type. The 100-foot cable is a low-loss LMR-195 type cable. (See the “Replacement Cables” section for more information.)



Caution: High voltages (as high as 300V DC) are present on the center conductor of the coaxial cable installed between the rear-panel “A” and “B” connectors during normal operation. Always turn off the instrument before attaching or changing cables.

The AVL-AV-1-B-W-KPMA is a highly flexible instrument. Aside from the internal trigger source, it can also be triggered or gated by external TTL-level signals. A front-panel pushbutton or a computer command can also be used to trigger the instrument.

The AVL-AV-1-B-W-KPMA features front panel keyboard and adjust knob control of the output pulse parameters along with a four line by 40-character backlit LCD display of the output amplitude, pulse width, pulse repetition frequency, and delay. The instrument includes memory to store up to four complete instrument setups. The operator may use the front panel or the computer interface to store a complete “snapshot” of all key instrument settings, and recall this setup at a later time.

SPECIFICATIONS

Model:	AVL-AV-1-B-W-KPMA
GPIB and RS-232 control:	included
Amplitude: (50 Ohm load)	AVL-AV-1-B-W-KPMA: 0 to ± 100 Volts
Rise time:	With six-inch cable installed: < 1 ns With 100-foot cable installed: < 2 ns
Fall time:	With six-inch cable installed: < 2 ns With 100-foot cable installed: < 5 ns
Pulse width:	With six-inch cable installed: 3-100 ns With 100-foot cable installed: 7-400 ns
PRF:	0 to 5 kHz
Jitter: (Ext trig in to pulse out)	± 100 ps $\pm 0.03\%$ of sync delay
Trigger required: (ext trig mode)	+ 5 Volts, 50 to 500 ns (TTL)
Sync delay:	Variable 0 to 200 ns, sync out to pulse out
Sync output:	+ 5 Volt, 200 ns, will drive 50 Ohm loads
Gate input:	Synchronous or asynchronous, active high or low, switchable. Suppresses triggering when active.
Connectors: OUT TRIG SYNC GATE	BNC BNC BNC BNC
Power requirements:	120/240 Volts (switchable) 50-60 Hz
Dimensions:	100 mm x 430 mm x 375 mm (3.9" x 17" x 14.8")
Chassis material:	cast aluminum frame & handles, blue vinyl on aluminum cover plates
Mounting:	Any
Temperature range:	+ 15° to + 40° C

INSTALLATION

VISUAL CHECK

After unpacking the instrument, examine to ensure that it has not been damaged in shipment. Visually inspect all connectors, knobs, liquid crystal displays (LCDs), and the handles. Confirm that a power cord, a GPIB cable, and two instrumentation manuals (this manual and the "OP1B Interface Programming Manual") are with the instrument. Confirm that two coaxial cables have been supplied with the instrument. In particular, confirm that 6-inch and 100-foot cables have been received. If the instrument has been damaged, file a claim immediately with the company that transported the instrument.

PLUGGING IN THE INSTRUMENT

Examine the rear of the instrument. There will be a male power receptacle, a fuse holder and the edge of the power selector card visible. Confirm that the power selector card is in the correct orientation.

For AC line voltages of 110-120V, the power selector card should be installed so that the "120" marking is visible from the rear of the instrument, as shown below:

For AC line voltages of 220-240V, the power selector card should be installed so that the "240" marking is visible from the rear of the instrument, as shown below:

If it is not set for the proper voltage, remove the fuse and then grasp the card with a pair of pliers and remove it. Rotate horizontally through 180 degrees. Reinstall the card and the correct fuse.

In the 120V setting, a 1.0A slow blow fuse is required. In the 240V setting, a 0.5A slow blow fuse is required.

LABVIEW DRIVERS

A LabVIEW driver for this instrument is available for download on the Avtech web site, at <http://www.avtechpulse.com/labview>. A copy is also available in National Instruments' Instrument Driver Library at <http://www.natinst.com/>.

FRONT PANEL CONTROLS

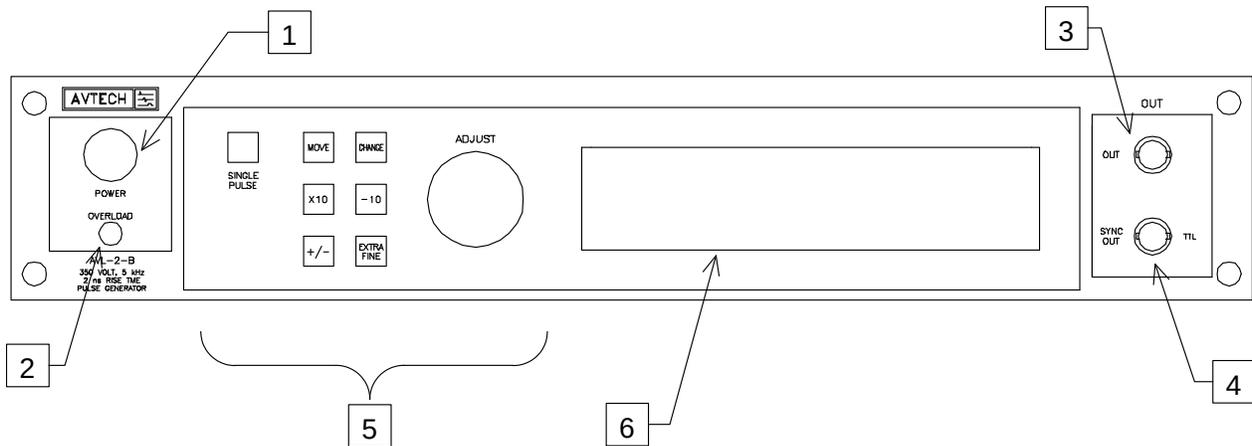

1. **POWER Switch.** The POWER push button switch applies AC prime power to the primaries of the transformer, turning the instrument on. The push button lamp (#382 type) is connected to the internal +15V DC supply.
2. **OVERLOAD.** The AVL-AV-1-B-W-KPMA is protected in its internal software against conflicting or dangerous settings. As an additional protective measure, an automatic overload circuit exists, which controls the front panel overload light. If the unit is overloaded (by operating at an exceedingly high duty cycle or by operating into a very low impedance), the protective circuit will turn the output of the instrument OFF and turn the indicator light ON. The light will stay ON (i.e. output OFF) for about 5 seconds after which the instrument will attempt to turn ON (i.e. light OFF) for about 1 second. If the overload condition persists, the instrument will turn OFF again (i.e. light ON) for another 5 seconds. If the overload condition has been removed, the instrument will turn on and resume normal operation.

This overload indicator may come on briefly at startup. This is not a cause for concern.

Note that the output circuit can withstand an infinite VSWR on the output port but is intended for operation with 50Ω loads.

3. **OUT CONNECTOR.** This BNC connector provides the main output signal, into load impedances of 50Ω.
4. **SYNC OUT.** This connector supplies a SYNC output that can be used to trigger other equipment, particularly oscilloscopes. This signal leads (or lags) the main output by a duration set by the "DELAY" controls and has an approximate amplitude of +3 Volts to $R_L > 1k\Omega$ with a pulse width of approximately 50 ns.

5. LIQUID CRYSTAL DISPLAY (LCD). This LCD is used in conjunction with the keypad to change the instrument settings. Normally, the main menu is displayed, which lists the key adjustable parameters and their current values. The "OP1B Interface Programming Manual" describes the menus and submenus in detail.
6. KEYPAD.

Control Name	Function
MOVE	This moves the arrow pointer on the display.
CHANGE	This is used to enter the submenu, or to select the operating mode, pointed to by the arrow pointer.
×10	If one of the adjustable numeric parameters is displayed, this increases the setting by a factor of ten.
÷10	If one of the adjustable numeric parameters is displayed, this decreases the setting by a factor of ten.
+/-	If one of the adjustable numeric parameters is displayed, and this parameter can be both positive or negative, this changes the sign of the parameter.
EXTRA FINE	This changes the step size of the ADJUST knob. In the extra-fine mode, the step size is twenty times finer than in the normal mode. This button switches between the two step sizes.
ADJUST	This large knob adjusts the value of any displayed numeric adjustable values, such as frequency, pulse width, etc. The adjust step size is set by the "EXTRA FINE" button. When the main menu is displayed, this knob can be used to move the arrow pointer.

REAR PANEL CONTROLS

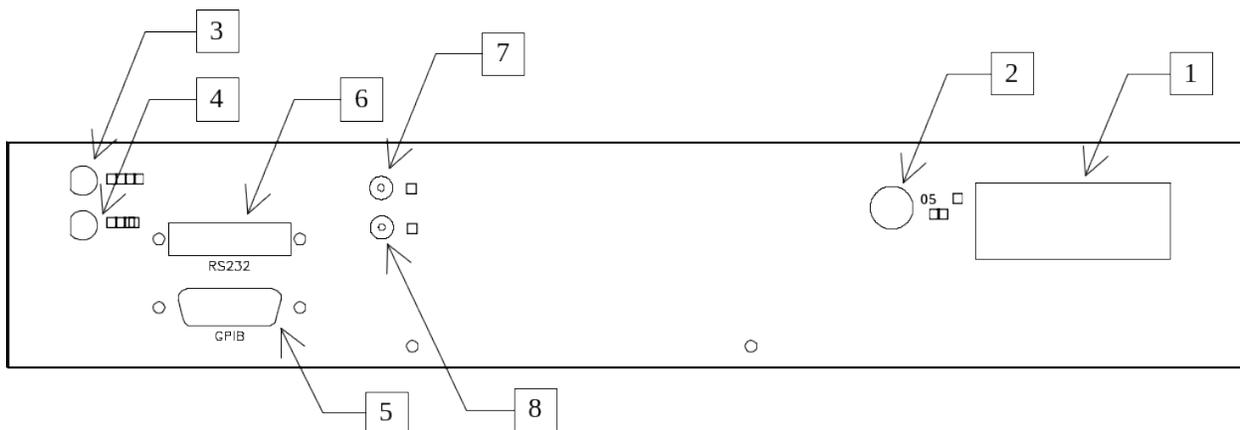

1. **AC POWER INPUT.** A three-pronged recessed male connector is provided on the back panel for AC power connection to the instrument. Also contained in this assembly is a slow-blow fuse and a removable card that can be removed and repositioned to switch between 120V AC in and 240V AC in.

For AC line voltages of 110-120V, the power selector card should be installed so that the “120” marking is visible from the rear of the instrument.

For AC line voltages of 220-240V, the power selector card should be installed so that the “240” marking is visible from the rear of the instrument.

If it is not set for the proper voltage, remove the fuse and then grasp the card with a pair of pliers and remove it. Rotate horizontally through 180 degrees. Reinstall the card and the correct fuse.

In the 120V setting, a 1.0A slow blow fuse is required. In the 240V setting, a 0.5A slow blow fuse is required.

2. **0.5A SB.** This fuse protects the DC power supply to the output stage.
3. **GATE.** This TTL-level (0 and +5V) logic input can be used to gate the triggering of the instrument. This input can be either active high or active low, depending on the front panel settings or programming commands. (The instrument triggers normally when this input is unconnected). When set to active high mode, this input is pulled-down to ground by a 1 k Ω resistor. When set to active low mode, this input is pulled-up to +5V by a 1 k Ω resistor.
4. **TRIG.** This TTL-level (0 and +5V) logic input can be used to trigger the instrument, if the instrument is set to triggering externally. The instrument triggers on the rising edge of this input. The input impedance of this input is 1 k Ω . (Depending on the length of cable attached to this input, and the source driving it, it may be desirable to

add a coaxial 50 Ohm terminator to this input to provide a proper transmission line termination. The Pasternack (www.pasternack.com) PE6008-50 BNC feed-thru 50 Ohm terminator is suggested for this purpose.)

5. GPIB Connector. A standard GPIB cable can be attached to this connector to allow the instrument to be computer-controlled. See the “OP1B Interface Programming Manual” for more details on GPIB control.
6. RS-232 Connector. A standard serial cable with a 25-pin male connector can be attached to this connector to allow the instrument to be computer-controlled. See the “OP1B Interface Programming Manual” for more details on RS-232 control.
7. A Connector. This instrument has two operating modes, which depend on the type of cable installed between the rear-panel “A” and “B” SMA connectors.

When the supplied 100-foot coaxial cable is installed between the rear-panel “A” and “B” SMA connectors, the pulse width may be varied from 7 ns to 400 ns, approximately. In this mode, the rise time is < 2 ns, and the fall time is < 5 ns. The pulse width controls are calibrated for use in this mode.

When the supplied six-inch coaxial cable is installed between the rear-panel “A” and “B” SMA connectors, the pulse width may be varied from 3 ns to 100 ns, approximately. In this mode, the rise time is < 1 ns, and the fall time is < 2 ns. The pulse width controls are calibrated for use in this mode. To obtain actual outputs of 3-100 ns in pulse width, the front-panel pulse width controls must be set to 140-240 ns, approximately.

The six-inch cable is a standard RG174A/U type. The 100-foot cable is a low-loss LMR-195 type cable. (See the “Replacement Cables” section for more information.)

 Caution: High voltages (as high as 300V DC) are present on the center conductor of the coaxial cable installed between the rear-panel “A” and “B” connectors during normal operation. Always turn off the instrument before attaching or changing cables.

8. B Connector. See above.

GENERAL INFORMATION

BASIC PULSE CONTROL

This instrument has two operating modes, which depend on the type of cable installed between the rear-panel “A” and “B” SMA connectors.

When the supplied 100-foot coaxial cable is installed between the rear-panel “A” and “B” SMA connectors, the pulse width may be varied from 7 ns to 400 ns, approximately. In this mode, the rise time is < 2 ns, and the fall time is < 5 ns. The pulse width controls are calibrated for use in this mode.

When the supplied six-inch coaxial cable is installed between the rear-panel “A” and “B” SMA connectors, the pulse width may be varied from 3 ns to 100 ns, approximately. In this mode, the rise time is < 1 ns, and the fall time is < 2 ns. The pulse width controls are calibrated for use in this mode. To obtain actual outputs of 3-100 ns in pulse width, the front-panel pulse width controls must be set to 140-240 ns, approximately.

The six-inch cable is a standard RG174A/U type. The 100-foot cable is a low-loss LMR-195 type cable. (See the “Replacement Cables” section for more information.)



Caution: High voltages (as high as 300V DC) are present on the center conductor of the coaxial cable installed between the rear-panel “A” and “B” connectors during normal operation. Always turn off the instrument before attaching or changing cables.

This instrument can be triggered by its own internal clock or by an external TTL trigger signal. In either case, two output channels respond to the trigger: OUT and SYNC.

- OUT. This is the main output. The maximum output voltage is 100V.
- SYNC. The SYNC pulse is a fixed-width TTL-level reference pulse used to trigger oscilloscopes or other measurement systems. When the delay is set to a positive value the SYNC pulse precedes the OUT pulse. When the delay is set to a negative value the SYNC pulse follows the OUT pulse.

These pulses are illustrated below, assuming internal triggering and a positive delay. All waveforms are shown with positive amplitudes.

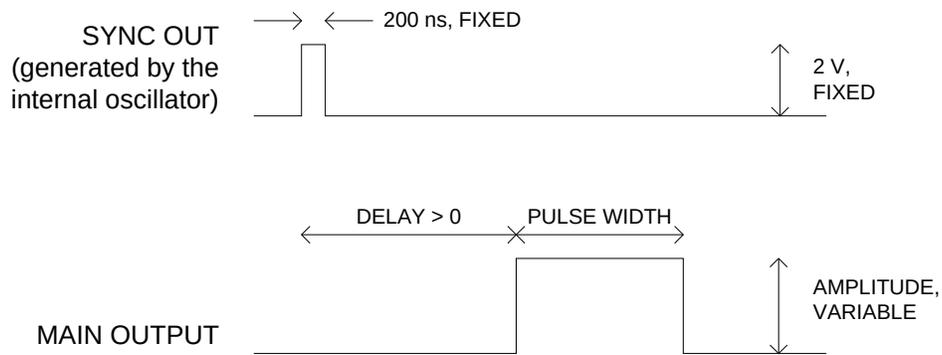

Figure A

If the delay is negative, the order of the SYNC and OUT pulses is reversed:

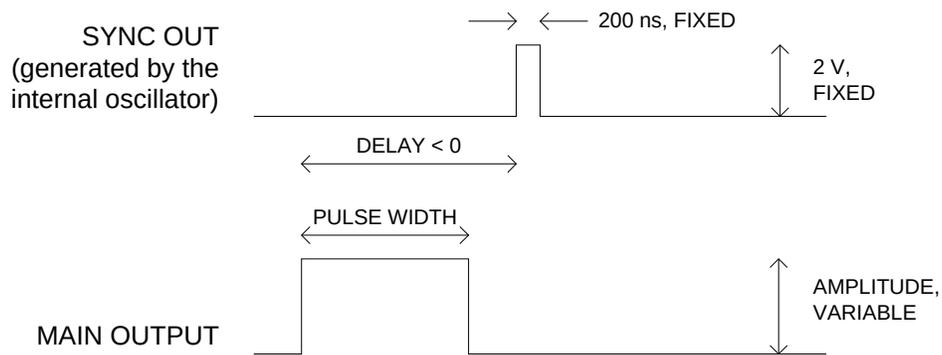

Figure B

The next figure illustrates the relationship between the signal when an external TTL-level trigger is used:

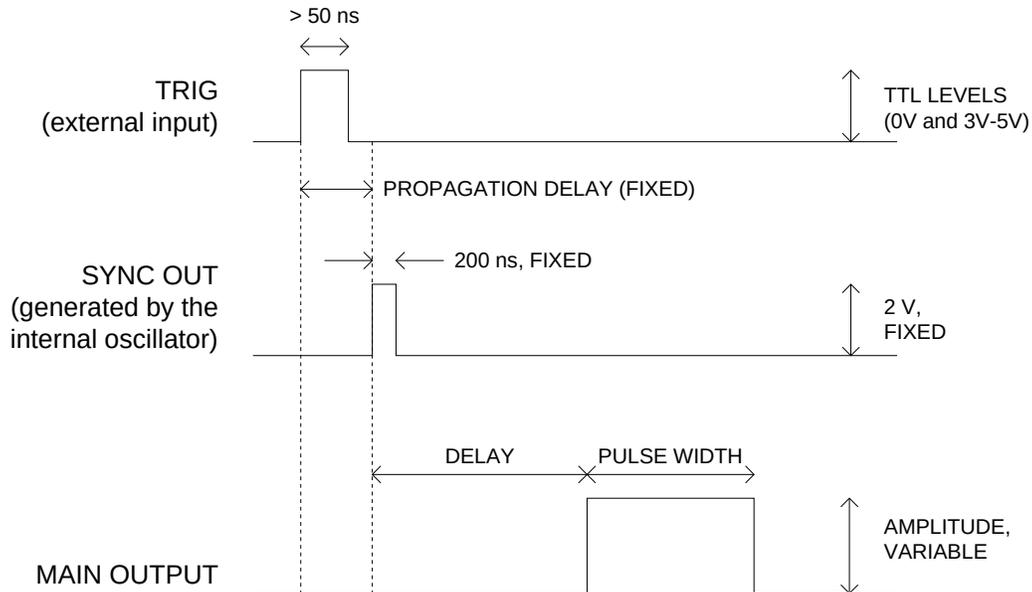

Figure C

As before, if the delay is negative, the order of the SYNC and OUT pulses is reversed.

In general, the delay, pulse width, and frequency (when in the internal mode), of the OUT pulse can be varied with front panel controls or via the GPIB or RS-232 computer interfaces.

TRIGGER MODES

This instrument has four trigger modes:

- Internal Trigger: the instrument controls the trigger frequency, and generates the clock internally.
- External Trigger: the instrument is triggered by an external TTL-level clock on the back-panel TRIG connector.
- Manual Trigger: the instrument is triggered by the front-panel "SINGLE PULSE" pushbutton.
- Hold Trigger: the instrument is set to not trigger at all.

These modes can be selected using the front panel trigger menu, or by using the appropriate programming commands. (See the "OP1B Interface Programming Manual" for more details.)

WARNING: The output stage may be damaged if triggered by an external signal at a pulse repetition frequency greater than 5 kHz.

GATING MODES

Triggering can be suppressed by a TTL-level signal on the rear-panel GATE connector. The instrument can be set to stop triggering when this input high or low, using the front-panel gate menu or the appropriate programming commands. When gated, the output will complete the full pulse width if the output is high, and then stop triggering. Pulses are not truncated.

TOP COVER REMOVAL

The interior of the instrument may be accessed by removing the four Phillips screws on the top panel. With the four screws removed, the top cover may be slid back (and off).

ELECTROMAGNETIC INTERFERENCE

To prevent electromagnetic interference with other equipment, all used outputs should be connected to shielded 50 Ω loads using shielded 50 Ω coaxial cables. Unused outputs should be terminated with shielded 50 Ω BNC terminators or with shielded BNC dust caps, to prevent unintentional electromagnetic radiation. All cords and cables should be less than 3m in length.

REPLACEMENT CABLES

As described in the “BASIC PULSE CONTROL” section, a coaxial cable must be installed between the rear-panel “A” and “B” SMA connectors.

Two cables are supplied with the instrument.

The six-inch cable is a standard RG174A/U type, with SMA male connectors on both ends. The Avtech part number for this cable is AV-RG174-6. An equivalent replacement cable, model PE3353-6, is available from Pasternack (www.pasternack.com).

The 100-foot cable is a low-loss Times Microwave (www.timesmicrowave.com) LMR-195 type cable that has been terminated with SMA male connectors. An equivalent replacement cable, model PE35784-1200, is available from Pasternack (www.pasternack.com).

PROTECTING YOUR INSTRUMENT

TURN OFF INSTRUMENT WHEN NOT IN USE

The lifetime of the switching elements in the pulse generator module is proportional to the running time of the instrument. For this reason the prime power to the instrument should be turned off when the instrument is not in use. In the case of failure, the switching elements are easily replaced following the procedure described in a following section.

TURN INSTRUMENT OFF WHEN CHANGING PULSE WIDTH CABLES

 Caution: High voltages (as high as 300V DC) are present on the center conductor of the coaxial cable installed between the rear-panel “A” and “B” connectors during normal operation. Always turn off the instrument before attaching or changing cables.

DO NOT EXCEED 5 kHz

The output stage may be damaged if triggered by an external signal at a pulse repetition frequency greater than 5 kHz.

USE A 50Ω LOAD

The output stage may be damaged if the output is not terminated into a 50Ω load.

OPERATIONAL CHECK

This section describes a sequence to confirm the basic operation of the instrument. It should be performed after receiving the instrument. It is a useful learning exercise as well.

Before proceeding with this procedure, finish reading this instruction manual thoroughly. Then read the “Local Control” section of the “OP1B Interface Programming Manual” thoroughly. The “Local Control” section describes the front panel controls used in this operational check - in particular, the MOVE, CHANGE, and ADJUST controls.

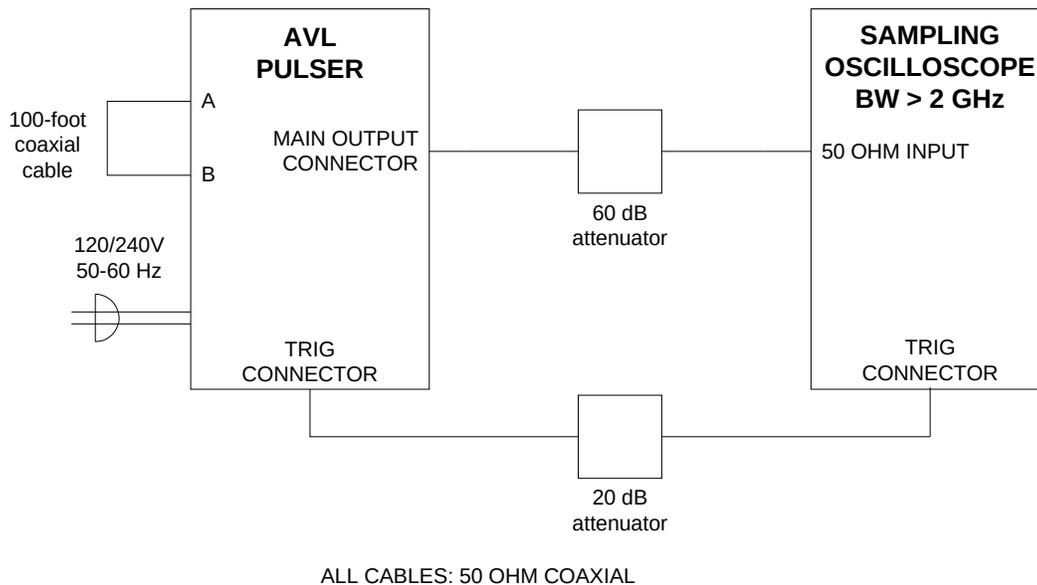

BASIC TEST ARRANGEMENT

1. Connect the pulse generator to a sampling oscilloscope as shown above. Note that:
 - a) The use of 60 dB attenuator at the sampling scope vertical input channel will insure a peak input signal to the sampling scope of less than 1 Volt. **WARNING:** This model may provide a peak output power in excess of 200 W. The peak power rating of the attenuator must exceed this limit. Factory tests are conducted using a Midwest Microwave model ATT-0527-20-SMA-07 attenuator.
 - b) The TRIG output channel provides TTL level signals (approximately 0 and +3V). To avoid overdriving the TRIG input channel of some scopes, a 20 dB attenuator should be placed at the input to the scope trigger channel.
 - c) The bandwidth capability of components and instruments used to display the pulse generator output signal (attenuators, cables, connectors, etc.) should

exceed 2 GHz.

- d) Set the oscilloscope to trigger externally with the vertical setting at 100 mV/div and the horizontal setting at 20 ns/div.
- e) The 100-foot coaxial cable must be installed between the rear-panel “A” and “B” connectors, prior to applying power.



Caution: High voltages (as high as 300V DC) are present on the center conductor of the coaxial cable installed between the rear-panel “A” and “B” connectors during normal operation. Always turn off the instrument before attaching or changing cables.

2. Turn on the AVL-AV-1-B-W-KPMA. The main menu will appear on the LCD.
3. To set the AVL-AV-1-B-W-KPMA to trigger from the internal clock at a PRF of 2 kHz:
 - a) The arrow pointer should be pointing at the frequency menu item. If it is not, press the MOVE button until it is.
 - b) Press the CHANGE button. The frequency submenu will appear. Rotate the ADJUST knob until the frequency is set at 2 kHz.
 - c) The arrow pointer should be pointing at the “Internal” choice. If it is not, press MOVE until it is.
 - d) Press CHANGE to return to the main menu.
4. To set the delay to 100 ns:
 - a) Press the MOVE button until the arrow pointer is pointing at the delay menu item.
 - b) Press the CHANGE button. The delay submenu will appear. Rotate the ADJUST knob until the delay is set at 100 ns.
 - c) The arrow pointer should be pointing at the “Normal” choice. If it is not, press MOVE until it is.
 - d) Press CHANGE to return to the main menu.
5. To set the pulse width to 50 ns:

- a) Press the MOVE button until the arrow pointer is pointing at the pulse width menu item.
 - b) Press the CHANGE button. The pulse width submenu will appear. Rotate the ADJUST knob until the pulse width is set at 50 ns.
 - c) The arrow pointer should be pointing at the "Normal" choice. If it is not, press MOVE until it is.
 - d) Press CHANGE to return to the main menu.
6. At this point, nothing should appear on the oscilloscope.
7. To enable the output:
- a) Press the MOVE button until the arrow pointer is pointing at the output menu item.
 - b) Press the CHANGE button. The output submenu will appear.
 - c) Press MOVE until the arrow pointer is pointing at the "ON" choice.
 - d) Press CHANGE to return to the main menu.
8. To change the output amplitude:
- a) Press the MOVE button until the arrow pointer is pointing at the amplitude menu item.
 - b) Press the CHANGE button. The amplitude submenu will appear. Rotate the ADJUST knob until the amplitude is set at +100V (or -100V for "-N" models).
 - c) Observe the oscilloscope. You should see 50 ns wide, 100V pulses. If you do not, you may need to adjust the delay setting to a value more compatible with your sampling oscilloscope. Repeat step 4 if required. You may also need to adjust the sampling scope controls.
 - d) Rotate the ADJUST knob. The amplitude as seen on the oscilloscope should vary. Return it to 100V.
 - e) ("-PN" units only) Press the +/- button on the front panel. The amplitude as seen on the oscilloscope should flip polarity, to -100V.
 - f) Press CHANGE to return to the main menu.

9. Try varying the pulse width, by repeating step (5). As you rotate the ADJUST knob, the pulse width on the oscilloscope will change. It should agree with the displayed value.

This completes the operational check.

PROGRAMMING YOUR PULSE GENERATOR

KEY PROGRAMMING COMMANDS

Please note that the pulse width commands are calibrated for use with the 100-foot coaxial cable installed between the rear-panel "A" and "B" connectors. (To obtain actual outputs of 3-100 ns in pulse width when using the six-inch cable, the pulse width controls must be set to 140-240 ns, approximately.)

The "OP1B Interface Programming Manual" describes in detail how to connect the pulse generator to your computer, and the programming commands themselves. A large number of commands are available; however, normally you will only need a few of these. Here is a basic sample sequence of commands that might be sent to the instrument after power-up:

*rst	(resets the instrument)
trigger:source internal	(selects internal triggering)
frequency 1000 Hz	(sets the frequency to 1000 Hz)
pulse:width 50 ns	(sets the pulse width to 50 ns)
pulse:delay 20 ns	(sets the delay to 20 ns)
volt:ampl 50	(sets the amplitude to +50 V)
	("-N" units should use "volt:ampl -50")
output on	(turns on the output)

For triggering a single event, this sequence would be more appropriate:

*rst	(resets the instrument)
trigger:source hold	(turns off all triggering)
pulse:width 50 ns	(sets the pulse width to 50 ns)
output on	(turns on the output)
volt:ampl 50	(sets the amplitude to +50 V)
	("-N" units should use "volt:ampl -50")
trigger:source immediate	(generates a single non-repetitive trigger event)
trigger:source hold	(turns off all triggering)
output off	(turns off the output)

To set the instrument to trigger from an external TTL signal applied to the rear-panel TRIG connector, use:

*rst	(resets the instrument)
trigger:source external	(selects external triggering)
pulse:width 50 ns	(sets the pulse width to 50 ns)
pulse:delay 1 us	(sets the delay to 1 us)

volt:ampl 50 (sets the amplitude to +50 V)
 ("N" units should use "volt:ampl -50")
 output on (turns on the output)

These commands will satisfy 90% of your programming needs.

ALL PROGRAMMING COMMANDS

For more advanced programmers, a complete list of the available commands is given below. These commands are described in detail in the "OP1B Interface Programming Manual". (Note: this manual also includes some commands that are not implemented in this instrument. They can be ignored.)

<u>Keyword</u>	<u>Parameter</u>	<u>Notes</u>
LOCAL		
OUTPut:		
:[STATe]	<boolean value>	
:PROTection		
:TRIPped?		[query only]
REMOTE		
[SOURce]:		
:FREQuency		
[:CW FIXed]	<numeric value>	
[SOURce]:		
:PULSe		
:PERiod	<numeric value>	
:WIDTh	<numeric value>	
:DCYClE	<numeric value>	
:HOLD	WIDTh DCYClE	
:DELay	<numeric value>	
:GATE		
:TYPE	ASYNc SYNc	
:LEVel	HIgh LOw	
[SOURce]:		
:VOLTage		
[:LEVel]		
[:IMMediate]		
[:AMPLitude]	<numeric value> EXTeRnal	
:PROTection		
:TRIPped?		[query only]
STATUS:		
:OPERation		
:[EVENt]?		[query only, always returns "0"]
:CONDition?		[query only, always returns "0"]
:ENABle	<numeric value>	[implemented but not useful]
:QUEStionable		
:[EVENt]?		[query only, always returns "0"]
:CONDition?		[query only, always returns "0"]
:ENABle	<numeric value>	[implemented but not useful]
SYSTEM:		

:COMMunicate		
:GPIB		
:ADDRESS	<numeric value>	
:SERial		
:CONTRol		
:RTS	ON IBFull RFR	
:[RECeive]		
:BAUD	1200 2400 4800 9600	
:BITS	7 8	
:ECHO	<boolean value>	
:PARity		
:[TYPE]	EVEN ODD NONE	
:SBITS	1 2	
:ERRor		
:[NEXT]?		[query only]
:COUNT?		[query only]
:VERSion?		[query only]
TRIGger:		
:SOURce	INTernal EXTernal MANual HOLD IMMEDIATE	
*CLS		[no query form]
*ESE	<numeric value>	
*ESR?		[query only]
*IDN?		[query only]
*OPC		
*SAV	0 1 2 3	[no query form]
*RCL	0 1 2 3	[no query form]
*RST		[no query form]
*SRE	<numeric value>	
*STB?		[query only]
*TST?		[query only]
*WAI		[no query form]

PERFORMANCE CHECKSHEET