



AVTECH ELECTROSYSTEMS LTD.

NANOSECOND WAVEFORM ELECTRONICS
SINCE 1975

P.O. BOX 265
OGDENSBURG, NY
U.S.A. 13669-0265

TEL: 888-670-8729 (USA & Canada) or +1-613-686-6675 (Intl)
FAX: 800-561-1970 (USA & Canada) or +1-613-686-6679 (Intl)

info@avtechpulse.com - <http://www.avtechpulse.com/>

BOX 5120, LCD MERIVALE
OTTAWA, ONTARIO
CANADA K2C 3H5

INSTRUCTIONS

MODEL AVM-1

5 VOLT, 25 MHz

HIGH SPEED PULSE GENERATOR MODULE

WITH 100 ps RISE TIME

SERIAL NUMBER: _____

WARRANTY

Avtech Electrosystems Ltd. warrants products of its manufacture to be free from defects in material and workmanship under conditions of normal use. If, within one year after delivery to the original owner, and after prepaid return by the original owner, this Avtech product is found to be defective, Avtech shall at its option repair or replace said defective item. This warranty does not apply to units which have been disassembled, modified or subjected to conditions exceeding the applicable specifications or ratings. This warranty is the extent of the obligation assumed by Avtech with respect to this product and no other warranty or guarantee is either expressed or implied.

TECHNICAL SUPPORT

Phone: 888-670-8729 (USA & Canada) or +1-613-686-6675 (International)

Fax: 800-561-1970 (USA & Canada) or +1-613-686-6679 (International)

E-mail: info@avtechpulse.com

World Wide Web: <http://www.avtechpulse.com>

TABLE OF CONTENTS

WARRANTY.....2

TECHNICAL SUPPORT.....2

TABLE OF CONTENTS.....3

INTRODUCTION.....4

AVAILABLE OPTIONS.....4

SPECIFICATIONS.....5

REGULATORY NOTES.....6

 FCC PART 18.....6

 EC DECLARATION OF CONFORMITY.....6

 DIRECTIVE 2002/95/EC (RoHS).....7

 DIRECTIVE 2002/96/EC (WEEE).....7

BASIC TEST ARRANGEMENT.....8

 CONTROLS - FRONT.....8

 CONTROLS - REAR.....9

 GENERAL OPERATING NOTES.....10

PERFORMANCE CHECK SHEET.....12

Manual Reference: /files/officefiles/instructword/avm/AVM-1,edition_h.odt.
Last modified February 29, 2024.
Copyright © 2024 Avtech Electrosystems Ltd, All Rights Reserved.

INTRODUCTION

The AVM-1 is a high performance DC-powered module capable of generating up to 5V into 50 Ω loads at repetition rates up to 25 MHz. The output pulse width is variable from 0.25 to 6 ns. The rise time is less than 100 ps, and the fall time is less than 250 ps.

Instruments with the "-P" model suffix can generate up to +5V, whereas instruments with the "-N" model suffix can generate up to -5V.

The AVM-1 must be triggered by an external TTL pulse (> 10 ns) applied to the "IN" connector.

The output is designed to drive 50 Ω loads. (A 50 Ω load is required for proper operation.) The output is AC-coupled.

This instrument is intended for use in research, development, test and calibration laboratories by qualified personnel.

AVAILABLE OPTIONS

The AVM-1 is available with several options:

-D Option: this option adds a 0-5 ns adjustable delay feature, which operates in both the internal and external trigger modes.

-ECL Option: the input trigger levels are ECL, rather than TTL.

-EA Option: the output amplitude can be controlled by an externally generated 0 to +10V analog control voltage.

-ED Option: the 0-5 ns delay can be controlled by an externally generated 0 to +10V analog control voltage. Units with the -ED option incorporate the -D option as well.

-EW Option: the output pulse width can be controlled by an externally generated 0 to +10V analog control voltage.

-M Option: a monitor output is provided.

-UDA Option: The instrument will be tested to ensure that the rise time (20%-80%) is less than 50 ps when operated at maximum amplitude at a PRF of 10 MHz.

SPECIFICATIONS

Model:	AVM-1
Maximum amplitude (into 50Ω) ^{1,2,8} :	5V
Pulse width (FWHM) ¹ :	0.25 - 6 ns
Maximum PRF:	25 MHz
Rise time (20% - 80%):	≤ 100 ps
Fall time (80% - 20%):	≤ 250 ps
Required load ⁷ :	50 Ohms
Polarity ³ :	specify -P or -N
Fixed propagation delay:	≤ 30 ns (Ext trig in to pulse out)
Variable delay, external trigger mode:	Optional ^{1,4} , 0 to 5 ns
Jitter (EXT TRIG in to pulse out):	±15 ps
DC offset or bias insertion ¹ :	Apply required DC offset to back panel solder terminals (± 50 Volts, 250 mA max)
External trigger	TTL-level (Low: 0V, High: +3V to +5V), 10 ns or wider.
Trigger input impedance:	50Ω (optionally 1 kΩ ⁷)
Monitor output option ⁵ :	Provides a 20 dB attenuated coincident replica of main output
Connectors (modules):	In, Out: SMA, Power: Solder terminals
Optional accessory kit: (attenuators and terminators)	Add the suffix "-AK1" to the model number to include the recommended accessory kit. Consists of three SMA, 18 GHz, 2 Watt attenuators (10, 20 & 30 dB) for use on the output, and two 50Ω, 1 GHz, 1 Watt feed-through terminators (one SMA, one BNC) for use on external trigger inputs.
Optional accessory kit: (coaxial cables and adapters)	Add the suffix "-AK8" to the model number to include the recommended accessory kit. Consists of one 12-inch SMA-M/SMA-M PE-SR405FL coaxial cable, one 12-inch SMA-M/SMA-MRG-316 coaxial cable, one 36-inch SMA-M/SMA-M RG-316 coaxial cable, one 24-inch SMA-M/BNC-M RG-316 coaxial cable, one 36-inch BNC-M/BNC-M RG58C/U coaxial cable, one SMA-F to BNC-M adapter, one SMA-M to BNC-F adapter, one SMA-F to SMA-F adapter, and one SMA-F to solder cup adapter
Dimensions (H x W x D):	43 x 66 x 107 mm (1.7" x 2.6" x 4.2")
Power requirement:	+24V DC
Temperature range:	+5°C to +40°C

- 1) For analog electronic control (0 to +10V) of amplitude, pulse width, delay or offset suffix model number with -EA or -EW or -ED or -EO. Electronic control units also include the standard front panel one-turn controls. Not available on -B units (since remote control is already provided digitally).
- 2) For -C units and modules, the minimum useful amplitude is 20% of the maximum. For -B units, it is 4% of the maximum, due to the use of internally-switched attenuators. For operation at lower amplitudes, best results will be obtained by setting the amplitude near full-scale and using external attenuators on the output.
- 3) Indicate desired polarity by suffixing model number with -P or -N (i.e. positive or negative), or -P-PN or -N-PN for dual polarity option on -C units and modules (where the suffix preceding -PN indicates the polarity at the mainframe output port), or -PN for the dual-polarity option on -B units.
- 4) Indicate delay option by suffixing model number with -D.
- 5) For monitor option add suffix -M.
- 6) A 50 Ohm load is required. Other loads may damage the instrument. Consult Avtech (info@avtechpulse.com) if you need to drive other load impedances.
- 7) An input impedance of ≥1 kΩ can also be provided (-Z1K option).
- 8) The maximum output amplitude may decline by up to 20% when operating at PRFs higher than 20% of the maximum specified PRF.

REGULATORY NOTES

FCC PART 18

This device complies with part 18 of the FCC rules for non-consumer industrial, scientific and medical (ISM) equipment.

This instrument is enclosed in a rugged metal chassis and uses a filtered power entry module (where applicable). The main output signal is provided on a shielded connector that is intended to be used with shielded coaxial cabling and a shielded load. Under these conditions, the interference potential of this instrument is low.

If interference is observed, check that appropriate well-shielded cabling is used on the output connectors. Contact Avtech (info@avtechpulse.com) for advice if you are unsure of the most appropriate cabling. Also, check that your load is adequately shielded. It may be necessary to enclose the load in a metal enclosure.

If any of the connectors on the instrument are unused, they should be covered with shielded metal "dust caps" to reduce the interference potential.

This instrument does not normally require regular maintenance to minimize interference potential. However, if loose hardware or connectors are noted, they should be tightened. Contact Avtech (info@avtechpulse.com) if you require assistance.

EC DECLARATION OF CONFORMITY



We Avtech Electrosystems Ltd.
 P.O. Box 5120, LCD Merivale
 Ottawa, Ontario
 Canada K2C 3H5

declare that this pulse generator meets the intent of Directive 89/336/EEC for Electromagnetic Compatibility. Compliance pertains to the following specifications as listed in the official Journal of the European Communities:

EN 50081-1 Emission

EN 50082-1 Immunity

and that this pulse generator meets the intent of the Low Voltage Directive 72/23/EEC as amended by 93/68/EEC. Compliance pertains to the following specifications as listed in the official Journal of the European Communities:

EN 61010-1:2001 Safety requirements for electrical equipment for measurement, control, and laboratory use

DIRECTIVE 2002/95/EC (RoHS)

This instrument is exempt from Directive 2002/95/EC of the European Parliament and of the Council of 27 January 2003 on the Restriction of the use of certain Hazardous Substances (RoHS) in electrical and electronic equipment. Specifically, Avtech instruments are considered "Monitoring and control instruments" (Category 9) as defined in Annex 1A of Directive 2002/96/EC. The Directive 2002/95/EC only applies to Directive 2002/96/EC categories 1-7 and 10, as stated in the "Article 2 - Scope" section of Directive 2002/95/EC.

DIRECTIVE 2002/96/EC (WEEE)

European customers who have purchased this equipment directly from Avtech will have completed a "WEEE Responsibility Agreement" form, accepting responsibility for WEEE compliance (as mandated in Directive 2002/96/EC of the European Union and local laws) on behalf of the customer, as provided for under Article 9 of Directive 2002/96/EC.

Customers who have purchased Avtech equipment through local representatives should consult with the representative to determine who has responsibility for WEEE compliance. Normally, such responsibilities will lie with the representative, unless other arrangements (under Article 9) have been made.

Requirements for WEEE compliance may include registration of products with local governments, reporting of recycling activities to local governments, and financing of recycling activities.

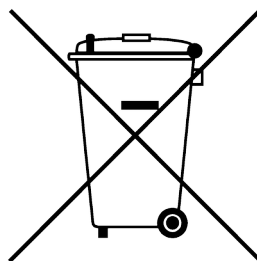

BASIC TEST ARRANGEMENT

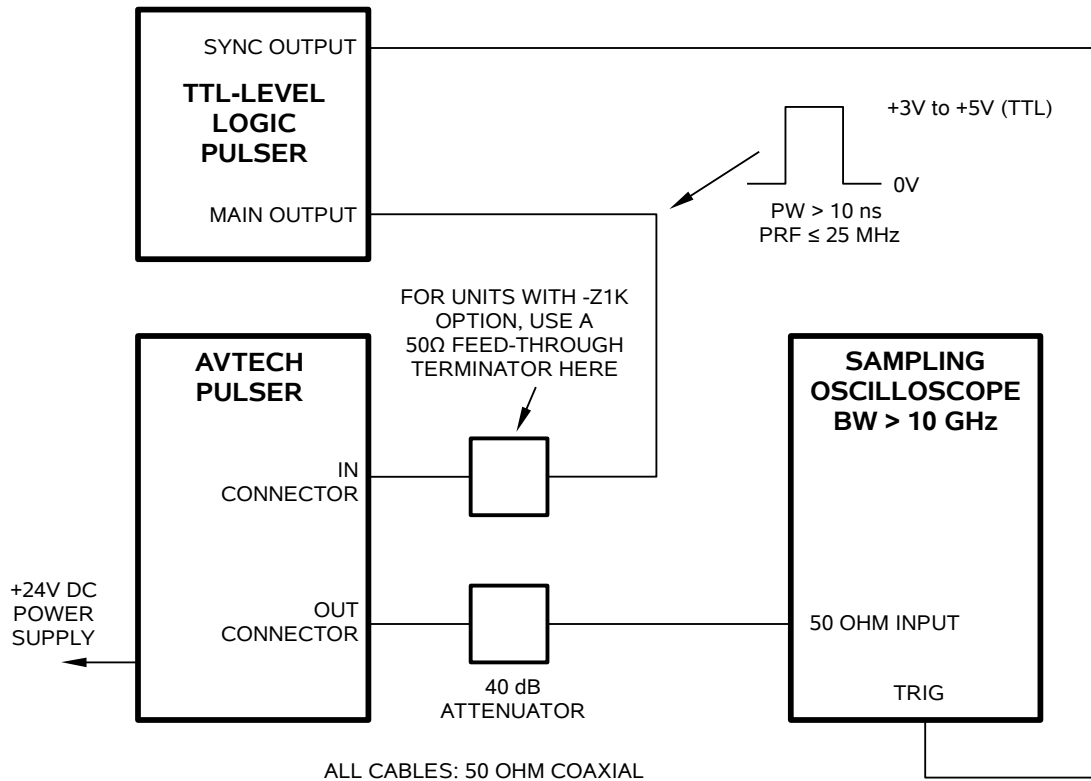

CONTROLS - FRONT

The location of the IN and OUT connectors, the optional "M" connector, and the amplitude and pulse width controls are shown in the photo below.



The “AMP” and “PW” controls may be adjusted using a screwdriver. Instruments with the -EA and -EW options will have solder terminal inputs to control the amplitude and pulse width, respectively, instead of screwdriver-adjustable controls. This is shown in the photo below:



CONTROLS - REAR

The location of the power terminals, the “12/25” switch, offset input are shown in the photo below.



The “12/25” switch should be set in the “12” position if the PRF is less than 12 MHz. For higher PRF the switch should normally be in the “25” position for optimal rise times and pulse widths. Some experimentation may be necessary to find the best operating mode.

GENERAL OPERATING NOTES

- 1) The bandwidth capability of components and instruments used to display the pulse generator output signal (attenuators, cables, connectors, etc.) should exceed 10 GHz.
- 2) The use of 40 dB attenuator on the output will insure a peak input signal to the sampling scope of less than one volt.
- 3) In general, the source pulse generator trigger delay control should be set in the 0.1 to 1.0 us range, for proper positioning of the output pulse on the sampling oscilloscope display.
- 4) The “12/25” switch should be set in the “12” position if the PRF is less than 12 MHz. For higher PRF the switch should normally be in the “25” position for optimal rise times and pulse widths.
- 5) The input trigger pulse width should be greater than 10 ns and less than one half of the pulse repetition frequency period. The unit triggers on the leading edge of the input trigger signal.
- 6) The output pulse width is controlled by means of the one-turn potentiometer (PW). The pot should initially be set maximum clockwise and the pulse width adjusted using an oscilloscope.
- 7) The output pulse amplitude is controlled by means of the one-turn potentiometer (AMP). The pulse width may change by several nanoseconds as the output amplitude is reduced from maximum to minimum. Therefore it is convenient to first set the desired amplitude and then set the desired pulse width. Rotation of the PW pot causes the position of the falling edge of the pulse to change.
- 8) Some properties of the output pulse may change as a function of the amplitude pot setting. For some demanding applications, it may be desirable to use a combination of external attenuators and the amplitude pot to achieve the desired output amplitude.
- 9) The AVM output pulse position or delay can be varied for up to 5 ns by means of the delay (DELAY) control. Rotating the delay control clockwise increases the delay. If the full 5 ns delay cannot be achieved then the input pulse width should be increased by a few nanoseconds. (Option)

- 10) It is recommended that the module be bolted to a heatsink, for cooling purposes. This will improve the stability of the output, by reducing thermal drift.
- 11) WARNING: The module may fail if triggered at a PRF greater than 25 MHz.
- 12) To DC offset the output pulse connect a DC power supply set to required DC offset value to the terminals marked "OS". The maximum attainable DC offset voltage is +50 volts. (Option).
- 13) The monitor output port (M) provides a coincident attenuated ($\div 11$) replica of the main output to a 50 ohm load. (Option).

PERFORMANCE CHECK SHEET