



AVTECH ELECTROSYSTEMS LTD.

NANOSECOND WAVEFORM ELECTRONICS
SINCE 1975

P.O. BOX 265
OGDENSBURG, NY
U.S.A. 13669-0265

TEL: 888-670-8729 (USA & Canada) or +1-613-686-6675 (Intl)
FAX: 800-561-1970 (USA & Canada) or +1-613-686-6679 (Intl)

info@avtechpulse.com - <http://www.avtechpulse.com/>

BOX 5120, LCD MERIVALE
OTTAWA, ONTARIO
CANADA K2C 3H4

INSTRUCTIONS

MODEL AVM-2

0 TO 15 VOLTS, 25 MHz

HIGH SPEED PULSE GENERATOR MODULE

WITH 100 ps RISE TIME

SERIAL NUMBER: _____

WARRANTY

Avtech Electrosystems Ltd. warrants products of its manufacture to be free from defects in material and workmanship under conditions of normal use. If, within one year after delivery to the original owner, and after prepaid return by the original owner, this Avtech product is found to be defective, Avtech shall at its option repair or replace said defective item. This warranty does not apply to units which have been disassembled, modified or subjected to conditions exceeding the applicable specifications or ratings. This warranty is the extent of the obligation assumed by Avtech with respect to this product and no other warranty or guarantee is either expressed or implied.

TECHNICAL SUPPORT

Phone: 888-670-8729 (USA & Canada) or +1-613-686-6675 (International)

Fax: 800-561-1970 (USA & Canada) or +1-613-686-6679 (International)

E-mail: info@avtechpulse.com

World Wide Web: <http://www.avtechpulse.com>

TABLE OF CONTENTS

WARRANTY.....2

TECHNICAL SUPPORT.....2

TABLE OF CONTENTS.....3

INTRODUCTION.....4

AVAILABLE OPTIONS.....4

SPECIFICATIONS.....5

BASIC TEST ARRANGEMENT.....6

CONTROLS - FRONT.....6

CONTROLS - REAR.....7

GENERAL OPERATING NOTES.....7

PERFORMANCE CHECK SHEET..... 10

Manual Reference: /fileserver1/officefiles/instructword/avm/AVM-2,edition7.odt.
Last modified February 29, 2024.
Copyright © 2024 Avtech Electrosystems Ltd, All Rights Reserved.

INTRODUCTION

The AVM-2 is a high performance DC-powered module capable of generating up to 15V into 50 Ω loads at repetition rates up to 25 MHz. The output pulse width is variable from 0.25 to 2 ns. The rise time is less than 100 ps, and the fall time is less than 250 ps.

Instruments with the "-P" model suffix can generate 0 to +15V, whereas instruments with the "-N" model suffix can generate 0 to -15V.

The AVM-2 must be triggered by an external TTL pulse (> 10 ns) applied to the "IN" connector.

The output is designed to drive 50 Ω loads. (A 50 Ω load is required for proper operation.) The output is AC-coupled.

This instrument is intended for use in research and development laboratories.

AVAILABLE OPTIONS

The AVM-2 is available with several options:

-D Option: this option adds a 0-5 ns adjustable delay feature, which operates in both the internal and external trigger modes.

-ECL Option: the input trigger levels are ECL, rather than TTL.

-EA Option: the output amplitude can be controlled by an externally generated 0 to +10V analog control voltage.

-ED Option: the 0-5 ns delay can be controlled by an externally generated 0 to +10V analog control voltage. Units with the -ED option incorporate the -D option as well.

-EW Option: the output pulse width can be controlled by an externally generated 0 to +10V analog control voltage.

-M Option: a monitor output is provided.

SPECIFICATIONS

Model:	AVM-2
Amplitude ^{1,2} : (into 50Ω load ⁷)	Variable to 15 Volts
Pulse width (FWHM) ¹ :	Variable 0.25 to 2.0 ns
PRF:	3 kHz to 25 MHz, periodic triggering (0 to 25 MHz when externally triggered)
Rise time (20% - 80%):	≤ 100 ps
Fall time (80% - 20%):	≤ 250 ps
Polarity ³ :	Positive or negative or both (specify)
Propagation delay:	≤ 30 ns (Ext trig in to pulse out)
Variable propagation delay option ^{1,4} :	0 to 5 ns
Jitter:	± 15 ps (Ext trig in to pulse out)
Trigger required:	TTL-level ⁶ (Low: 0V, High: +3V to +5V), 10 ns or wider. 50Ω input impedance ⁸ .
Monitor output option ⁵ :	Provides a 20 dB attenuated coincident replica of main output
Connectors:	In, Out: SMA, Power: Solder terminals
Dimensions (H x W x D):	43 x 66 x 107 mm (1.7" x 2.6" x 4.2")
Power requirement:	+24V DC
Chassis material:	Cast aluminum, blue enamel
Temperature range:	+5°C to +40°C

1) For electronic control (0 to +10V) of amplitude, pulse width, delay or offset suffix model number with -EA or -EW or -ED or -EO. Electronic control units also include the standard front panel one-turn controls.

2) For operation at amplitudes of less than 20% of full-scale, best results will be obtained by setting the amplitude near full-scale and using external attenuators on the output.

3) Indicate desired polarity by suffixing model number with -P or -N (i.e. positive or negative)).

4) Indicate delay option by suffixing model number with -D.

5) For monitor option add suffix -M.

6) For ECL-level (-1.6V and -0.8V) triggering instead, add the suffix -ECL to the model number. The internal ECL termination is 50 Ohms to -2V.

7) A 50 Ohm load is required. Other loads may damage the instrument. Consult Avtech (info@avtechpulse.com) if you need to drive other load impedances.

8) An input impedance of ≥1 kΩ can also be provided (-Z1K option).

BASIC TEST ARRANGEMENT

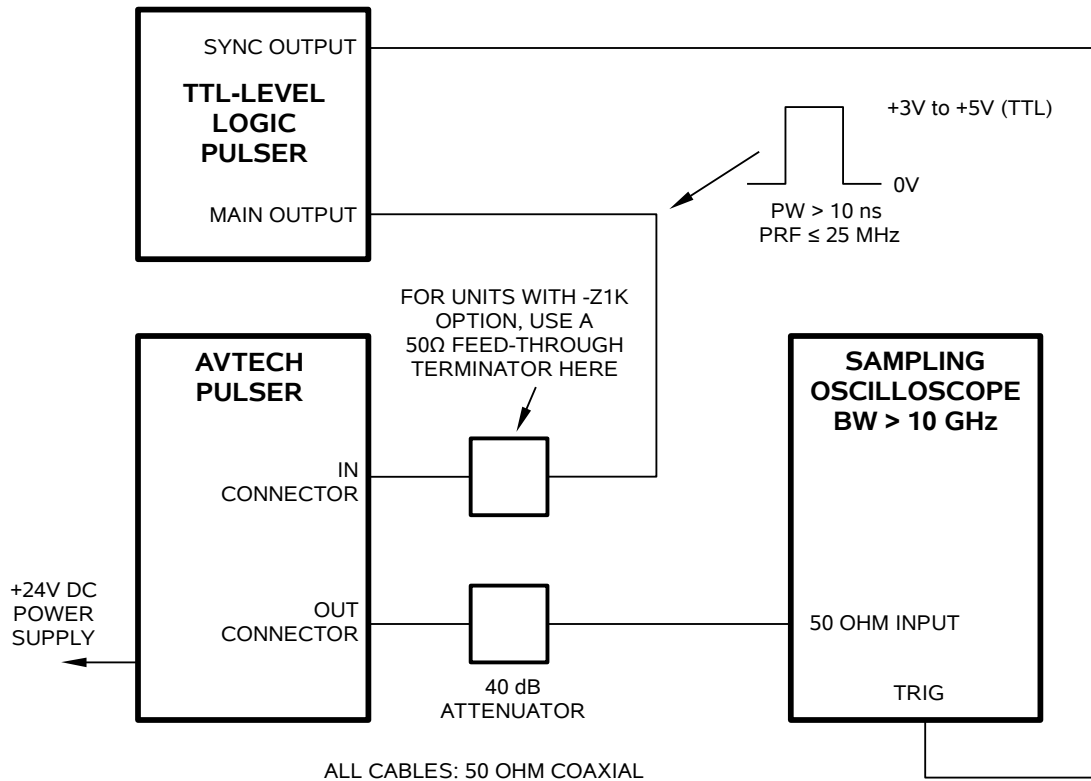

CONTROLS - FRONT

The location of the IN and OUT connectors, the optional "M" connector, and the amplitude and pulse width controls are shown in the photo below.



The “AMP” and “PW” controls may be adjusted using a screwdriver.

Units with the -EA option will have a solder terminal to control the amplitude, rather than a screwdriver-adjustable trimpot. The amplitude is then controlled by a 0 to +10V DC voltage applied to the solder terminal.

Units with the -EW option will have a solder terminal to control the pulse width, rather than a screwdriver-adjustable trimpot. The pulse width is then controlled by a 0 to +10V DC voltage applied to the solder terminal.

Units with the -D option will have an additional screwdriver-adjustable trimpot, which controls the 0 to 5 ns delay feature. Units with the -ED option will have a solder terminal to control the 0 to 5 ns delay, rather than a screwdriver-adjustable trimpot. The 0 to 5 ns delay is then controlled by a 0 to +10V DC voltage applied to the solder terminal.

CONTROLS - REAR

The location of the power terminals, the “12/25” switch, offset input are shown in the photo below.



The “12/25” switch should be set in the “12” position if the PRF is less than 12 MHz. For higher PRF the switch should normally be in the “25” position for optimal rise times and pulse widths.

GENERAL OPERATING NOTES

- 1) The bandwidth capability of components and instruments used to display the pulse generator output signal (attenuators, cables, connectors, etc.) should exceed 10

GHz.

- 2) The use of 40 dB attenuator on the output will insure a peak input signal to the sampling scope of less than one volt.
- 3) In general, the source pulse generator trigger delay control should be set in the 0.1 to 1.0 μ s range, for proper positioning of the output pulse on the sampling oscilloscope display.
- 4) The input impedance of the TRIG connector is normally 50 Ohms, unless the -Z1K option has been ordered (in which case the input impedance is 1 kilohm). If the -Z1K option has been ordered, best results will be obtained by installing a 50 Ohm feed-through terminator on the TRIG input, to avoid transmission line reflections and false triggering.
- 5) The "12/25" switch should be set in the "12" position if the PRF is less than 12 MHz. For higher PRF the switch should normally be in the "25" position for optimal rise times and pulse widths.
- 6) The input trigger pulse width should be greater than 10 ns and less than one half of the pulse repetition frequency period. The unit triggers on the leading edge of the input trigger signal.
- 7) The output pulse width is controlled by means of the one-turn potentiometer (PW). The pot should initially be set maximum clockwise and the pulse width adjusted using an oscilloscope.
- 8) The output pulse amplitude is controlled by means of the one-turn potentiometer (AMP). The pulse width may change by several nanoseconds as the output amplitude is reduced from maximum to minimum. Therefore it is convenient to first set the desired amplitude and then set the desired pulse width. Rotation of the PW pot causes the position of the falling edge of the pulse to change.
- 9) Some properties of the output pulse may change as a function of the amplitude pot setting. For some demanding applications, it may be desirable to use a combination of external attenuators and the amplitude pot to achieve the desired output amplitude.
- 10) The AVM output pulse position or delay can be varied for up to 5 ns by means of the delay (DELAY) control. Rotating the delay control clockwise increases the delay. If the full 5 ns delay cannot be achieved then the input pulse width should be increased by a few nanoseconds. (Option)
- 11) It is recommended that the module be bolted to a heatsink, for cooling purposes. This will improve the stability of the output, by reducing thermal drift.
- 12) WARNING: The module may fail if triggered at a PRF greater than 25 MHz.

- 13) To DC offset the output pulse connect a DC power supply set to required DC offset value to the terminals marked "OS". The maximum attainable DC offset voltage is +50 volts. (Option).
- 14) The monitor output port (M) provides a coincident attenuated ($\div 10$) replica of the main output to a 50 ohm load. (Option).

PERFORMANCE CHECK SHEET