

INSTRUCTIONS

MODEL AVM-1-P PULSE GENERATOR

S.N.:

WARRANTY

Avtech Electrosystems Ltd. warrants products of its manufacture to be free from defects in material and workmanship under conditions of normal use. If, within one year after delivery to the original owner, and after prepaid return by the original owner, this Avtech product is found to be defective, Avtech shall at its option repair or replace said defective item. This warranty does not apply to units which have been disassembled, modified or subjected to conditions exceeding the applicable specifications or ratings. This warranty is the extent of the obligation assumed by Avtech with respect to this product and no other warranty or guarantee is either expressed or implied.

TECHNICAL SUPPORT

Phone: 613-226-5772 or 1-800-265-6681

Fax: 613-226-2802 or 1-800-561-1970

E-mail: info@avtechpulse.com

World Wide Web: <http://www.avtechpulse.com>

TABLE OF CONTENTS

WARRANTY.....	2
FIG. 1: PULSE GENERATOR TEST ARRANGEMENT.....	5
GENERAL OPERATING INSTRUCTIONS.....	6
PERFORMANCE CHECK SHEET.....	8

Manual Reference: /fileserver1/officefiles/instructword/avm/older manuals/AVM-1-P-edc.doc, created November 18, 2003

FIG. 1: PULSE GENERATOR TEST ARRANGEMENT

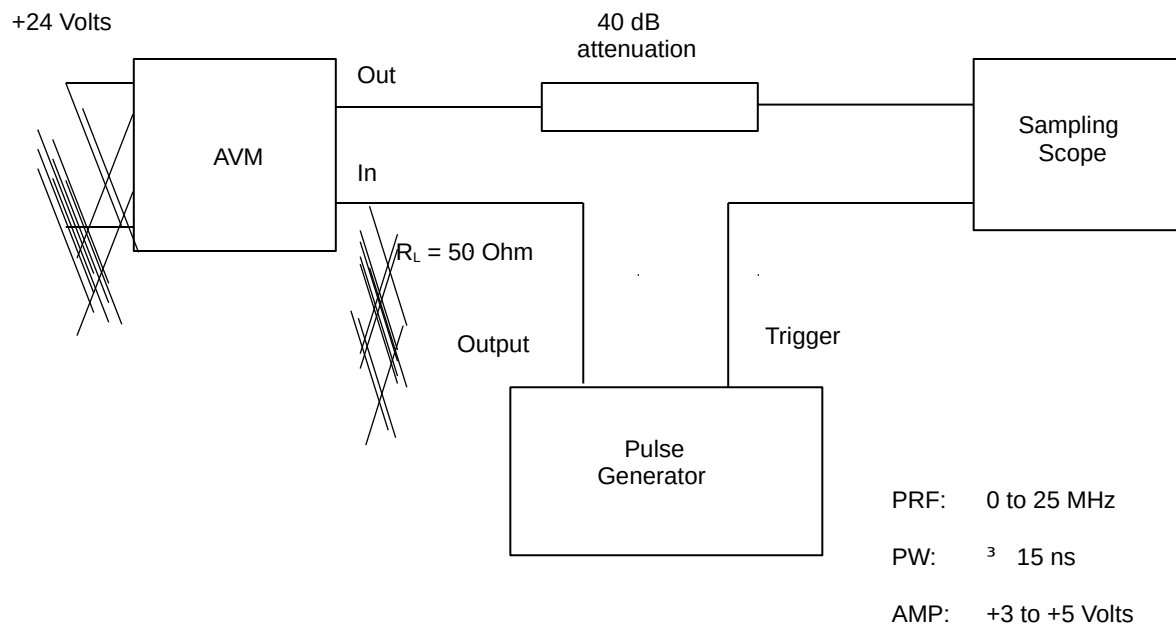

Power line: +24 Volts/0.50 Amps DC, shielded twisted pair, < 3 meters length

Control lines: 1 – Coaxial line, (trigger), SMA connector, < 1 meter length

Output: Coaxial, SMA, < 1 meter length

GENERAL OPERATING INSTRUCTIONS

- 1) The bandwidth capability of components and instruments used to display the pulse generator output signal (attenuators, cables, connectors, etc.) should exceed ten gigahertz.
- 2) The use of 40 db attenuator will insure a peak input signal to the sampling scope of less than one volt.
- 3) In general, the source pulse generator trigger delay control should be set in the 0.1 to 1.0 us range.*
- 4) When testing using a general purpose 50 ohm laboratory pulse generator as the input trigger signal source, the input signal should be applied via a 50 ohm feed-through load or alternatively, the input to the AVM unit should be shunted with a 50 ohm resistor. This will prevent reflection (and degradation of the input pulse waveform) caused by the high impedance at the IN port. However, when triggering from a TTL source, no 50 ohm feed-through load or resistor is necessary but lead length should be as short as possible. High-speed TTL Schottky logic is recommended for the driving circuitry.
- 5) The input trigger pulse width should be greater than 15 ns and less than one half of the pulse repetition frequency period. The unit triggers on the leading edge of the input trigger signal.
- 6) The output pulse width is controlled by means of the one-turn potentiometer (PW). The pot should initially be set maximum clockwise and the pulse width adjusted using an oscilloscope.
- 7) To voltage control the output pulse width (EW Option). Apply 0 to +10V to the front panel "PW" solder terminal ($R_{IN} \geq 10K$).
- 8) The output pulse amplitude is controlled by means of the one-turn potentiometer (AMP). The pulse width may change by several nanoseconds as the output amplitude is reduced from maximum to minimum. Therefore it is convenient to first set the desired amplitude and then set the desired pulse width. Rotation of the PW pot causes the position of the falling edge of the pulse to change.
- 9) To voltage control the output amplitude (EA option). Apply 0 to +10V to the front panel "AMP" solder terminal ($R_{IN} \geq 10K$).
- 10) Some properties of the output pulse may change as a function of the amplitude pot setting. For some demanding applications, it may be

desirable to use a combination of external attenuators and the amplitude pot to achieve the desired output amplitude.

- 11) The AVM output pulse position or delay can be varied for up to 5 ns by means of the delay (DELAY) control. Rotating the delay control clockwise increases the delay. If the full 5 ns delay cannot be achieved then the input pulse width should be increased by a few nanoseconds. (option)
- 12) WARNING: Model AVM- may fail if triggered at a PRF greater than 25.0 MHz.
- 13) The Model AVM- pulse generator can withstand and infinite VSWR on the output port.
- 14) The AVM unit requires a maximum prime input power of about 12 watts. It is Therefore strongly recommended that the unit be heatsunk in order to maintain a moderate chassis temperature.
- 15) To DC offset the output pulse connect a DC power supply set to the required DC offset value to the terminals marked O.S. The maximum attainable DC offset voltage is 50 volts.
- 16) 1-10 MHz Switch This switch should normally be in the 1 MHz position. For operation at PRF in the 10 to 25 MHz range, a smoother pulse top may be obtained by setting the switch in the 10 MHz position.
- 17) For additional assistance:

Tel: 613-226-5772

Fax: 613-226-2802

Email: info@avtechpulse.com

*The stability of the display on some sampling scopes is very sensitive to this delay, particularly at high PRF (eg. 10 to 25 MHz). If necessary, consult your sample scope instructions manual for the proper triggering method.

PERFORMANCE CHECK SHEET