

INSTRUCTIONS

MODEL AVMP-1A-B-P-FOICC

0 TO +5 VOLTS, 5 to 100 ns & 2.5 ns PULSE WIDTHS

DUAL CHANNEL
HIGH PERFORMANCE PULSE GENERATOR
WITH IEEE 488.2 AND RS-232 CONTROL

SERIAL NUMBER: _____

WARRANTY

Avtech Electrosystems Ltd. warrants products of its manufacture to be free from defects in material and workmanship under conditions of normal use. If, within one year after delivery to the original owner, and after prepaid return by the original owner, this Avtech product is found to be defective, Avtech shall at its option repair or replace said defective item. This warranty does not apply to units which have been disassembled, modified or subjected to conditions exceeding the applicable specifications or ratings. This warranty is the extent of the obligation assumed by Avtech with respect to this product and no other warranty or guarantee is either expressed or implied.

TECHNICAL SUPPORT

Phone: 613-226-5772 or 1-800-265-6681

Fax: 613-226-2802 or 1-800-561-1970

E-mail: info@avtechpulse.com

World Wide Web: <http://www.avtechpulse.com>

TABLE OF CONTENTS

<i>WARRANTY</i>	2
<i>TECHNICAL SUPPORT</i>	2
<i>TABLE OF CONTENTS</i>	3
<i>INTRODUCTION</i>	4
<i>SPECIFICATIONS</i>	5
<i>INSTALLATION</i>	6
<i>VISUAL CHECK</i>	6
<i>PLUGGING IN THE INSTRUMENT</i>	6
<i>FRONT PANEL CONTROLS</i>	7
<i>REAR PANEL CONTROLS</i>	9
<i>GENERAL INFORMATION</i>	11
<i>BASIC PULSE CONTROL</i>	11
<i>TRIGGER MODES</i>	13
<i>GATING MODES</i>	13
<i>PULSE WIDTH / AMPLITUDE INTERACTION</i>	13
<i>OBTAINING OPTIMUM JITTER PERFORMANCE</i>	14
<i>TOP COVER REMOVAL</i>	14
<i>ELECTROMAGNETIC INTERFERENCE</i>	14
<i>RACK MOUNTING</i>	14
<i>PROTECTING YOUR INSTRUMENT</i>	15
<i>DO NOT EXCEED 1 MHz</i>	15
<i>USE A 50 Ω LOAD</i>	15
<i>NEVER APPLY AN EXTERNAL VOLTAGE TO THE OUTPUT</i>	15
<i>OPERATIONAL CHECK</i>	16
<i>PROGRAMMING YOUR PULSE GENERATOR</i>	20
<i>KEY PROGRAMMING COMMANDS</i>	20
<i>ALL PROGRAMMING COMMANDS</i>	21
<i>PERFORMANCE CHECKSHEET</i>	23

INTRODUCTION

The AVMP-1A-B-P-FOICC is a high performance, GPIB and RS232-equipped dual-channel pulse generator. Output channel 1 is capable of generating 0 to +5V pulse into 50 Ω loads, with pulse widths variable from 5 to 100 ns, and a rise time of 100 ps or less. Output channel 2 is also capable of generating 0 to +5V pulse into 50 Ω loads, but with a fixed pulse width of 2.5 ns, and a rise time of 250 ps or less.

The AVMP-1A-B-P-FOICC is a highly flexible instrument. Aside from the internal trigger source, it can also be triggered or gated by external TTL-level signals. A front-panel pushbutton or a computer command can also be used to trigger the instrument.

The AVMP-1A-B-P-FOICC features front panel keyboard and adjust knob control of the output pulse parameters along with a four line by 40 character back-lit LCD display of the output amplitude, pulse width, pulse repetition frequency, and delay. The instrument includes memory to store up to four complete instrument setups. The operator may use the front panel or the computer interface to store a complete "snapshot" of all key instrument settings, and recall this setup at a later time.

SPECIFICATIONS

Model:	AVMP-1A-B-P-FOICC	
	Channel 1	Channel 2
GPIB and RS-232 control:	included	
Amplitude: (50 Ohm load)	0 to +5 Volts	0 to +5 Volts
Rise, fall time:	≤ 100 ps	≤ 250 ps
Pulse width:	5 to 100 ns, variable	2.5 ns, fixed
PRF:	1 Hz to 1 MHz	
Polarity:	Positive	
Jitter: (Ext trig in to pulse out)	± 35 ps $\pm 0.015\%$ of sync delay	
DC offset or bias insertion:	Apply required DC offset to back panel solder terminals (± 50 V, 250 mA maximum)	
Trigger required: (ext trig mode)	+ 5 Volts, 10 ns or wider (TTL)	
Sync delay:	Variable 0 to 200 ns, sync out to pulse out	
Sync output:	+ 3 Volt, 200 ns, will drive 50 Ohm loads	
Gate input:	Synchronous, active high or low, switchable. Suppresses triggering when active.	
Connectors: OUT TRIG SYNC GATE	SMA BNC BNC BNC	
Power requirements:	120/240 Volts (switchable) 50-60 Hz	
Dimensions:	100 mm x 430 mm x 375 mm (3.9" x 17" x 14.8")	
Chassis material:	cast aluminum frame & handles, blue vinyl on aluminum cover plates	
Mounting:	Any	
Temperature range:	+ 15° to + 40° C	

INSTALLATION

VISUAL CHECK

After unpacking the instrument, examine to ensure that it has not been damaged in shipment. Visually inspect all connectors, knobs, liquid crystal displays (LCDs), and the handles. Confirm that a power cord and two instrumentation manuals (this manual and the "OP1B Interface Programming Manual") are with the instrument. If the instrument has been damaged, file a claim immediately with the company that transported the instrument.

PLUGGING IN THE INSTRUMENT

Examine the rear of the instrument. There will be a male power receptacle, a fuse holder and the edge of the power selector card visible. Confirm that the power selector is in the correct orientation - it should be marked either 120 or 240, indicating whether it expects 120V AC or 240V AC. If it is not set for the proper voltage, remove the fuse and then grasp the card with a pair of pliers and remove it. Rotate horizontally through 180 degrees. Reinstall the card and the correct fuse. In the 120V setting, a 1.0A slow blow fuse is required. In the 240V setting, a 1/2A slow blow fuse is required.

FRONT PANEL CONTROLS

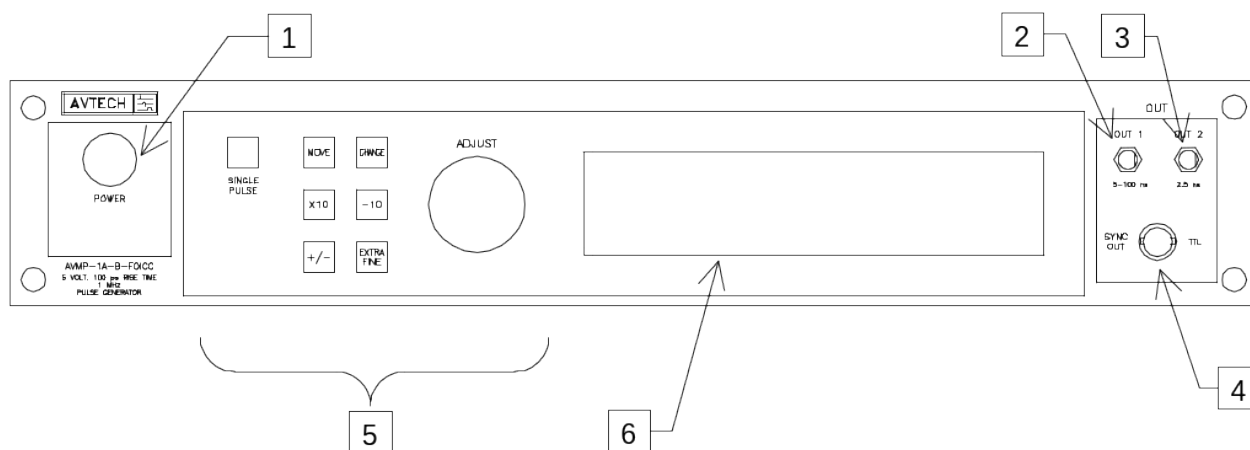

1. **POWER Switch.** The POWER push button switch applies AC prime power to the primaries of the transformer, turning the instrument on. The push button lamp (#382 type) is connected to the internal +15V DC supply.
2. **OUT CONNECTOR.** This SMA connector provides the Channel 1 output signal, into load impedances of 50Ω. (NOTE: This unit *requires* a 50Ω load to function properly).
3. **OUT CONNECTOR.** This SMA connector provides the Channel 2 output signal, into load impedances of 50Ω. (NOTE: This unit *requires* a 50Ω load to function properly).
4. **SYNC OUT.** This connector supplies a SYNC output that can be used to trigger other equipment, particularly oscilloscopes. This signal leads (or lags) the main output by a duration set by the "DELAY" controls and has an approximate amplitude of +3 Volts to $R_L > 1k\Omega$ with a pulse width of approximately 200 ns.
5. **LIQUID CRYSTAL DISPLAY (LCD).** This LCD is used in conjunction with the keypad to change the instrument settings. Normally, the main menu is displayed, which lists the key adjustable parameters and their current values. The "OP1B Interface Programming Manual" describes the menus and submenus in detail.
6. **KEYPAD.**

Control Name	Function
MOVE	This moves the arrow pointer on the display.
CHANGE	This is used to enter the submenu, or to select the operating mode, pointed to by the arrow pointer.
×10	If one of the adjustable numeric parameters is displayed, this increases the setting by a factor of ten.

÷10	If one of the adjustable numeric parameters is displayed, this decreases the setting by a factor of ten.
+/-	If one of the adjustable numeric parameters is displayed, and this parameter can be both positive or negative, this changes the sign of the parameter.
EXTRA FINE	This changes the step size of the ADJUST knob. In the extra-fine mode, the step size is twenty times finer than in the normal mode. This button switches between the two step sizes.
ADJUST	<p>This large knob adjusts the value of any displayed numeric adjustable values, such as frequency, pulse width, etc. The adjust step size is set by the "EXTRA FINE" button.</p> <p>When the main menu is displayed, this knob can be used to move the arrow pointer.</p>

REAR PANEL CONTROLS

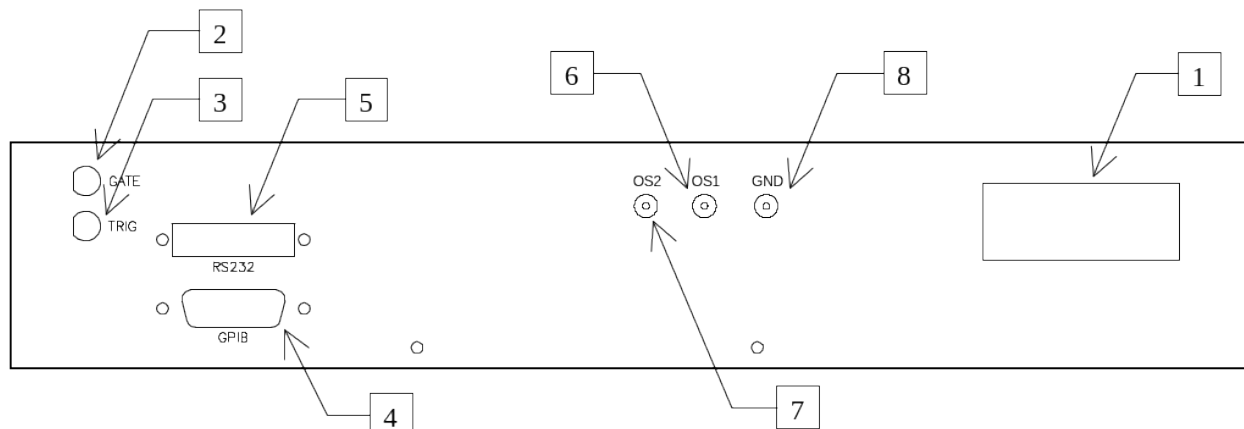

1. **AC POWER INPUT.** A three-pronged recessed male connector is provided on the back panel for AC power connection to the instrument. Also contained in this assembly is a slow blow fuse and a removable card that can be removed and repositioned to switch between 120V AC in and 240V AC in.
2. **GATE.** This TTL-level (0 and +5V) logic input can be used to gate the triggering of the instrument. This input can be either active high or active low, depending on the front panel settings or programming commands. (The instrument triggers normally when this input is unconnected).
3. **TRIG.** This TTL-level (0 and +5V) logic input can be used to trigger the instrument, if the instrument is set to triggering externally. The instrument triggers on the rising edge of this input.
4. **GPIB Connector.** A standard GPIB cable can be attached to this connector to allow the instrument to be computer-controlled. See the “OP1B Interface Programming Manual” for more details on GPIB control.
5. **RS-232 Connector.** A standard serial cable with a 25-pin male connector can be attached to this connector to allow the instrument to be computer-controlled. See the “OP1B Interface Programming Manual” for more details on RS-232 control.
6. **OS1 Connector.** The desired Channel 1 DC offset is applied to this connector. Internally, it is connected to the output centre conductor via a high quality RF inductor. Do not exceed $\pm 50V$, 250 mA.
7. **OS2 Connector.** The desired Channel 2 DC offset is applied to this connector. Internally, it is connected to the output centre conductor via a high quality RF inductor. Do not exceed $\pm 50V$, 250 mA.

8. GND Connector. This solder terminal is connector to the chassis ground.

GENERAL INFORMATION

BASIC PULSE CONTROL

This instrument can be triggered by its own internal clock or by an external TTL trigger signal. In either case, three output channels respond to the trigger:

- OUT 1. This is the Channel 1 output. The maximum output voltage is +5V.
- OUT 2. This is the Channel 2 output. The maximum output voltage is +5V.
- SYNC. The SYNC pulse is a fixed-width TTL-level reference pulse used to trigger oscilloscopes or other measurement systems. When the delay is set to a positive value the SYNC pulse precedes the OUT pulse. When the delay is set to a negative value the SYNC pulse follows the OUT pulse.

These pulses are illustrated below, assuming internal triggering and a positive delay:

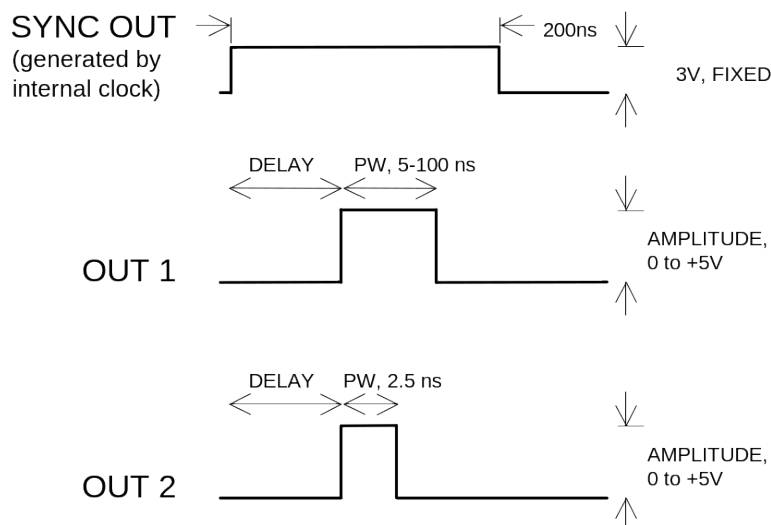

Figure A

If the delay is negative, the order of the SYNC and OUT pulses is reversed:

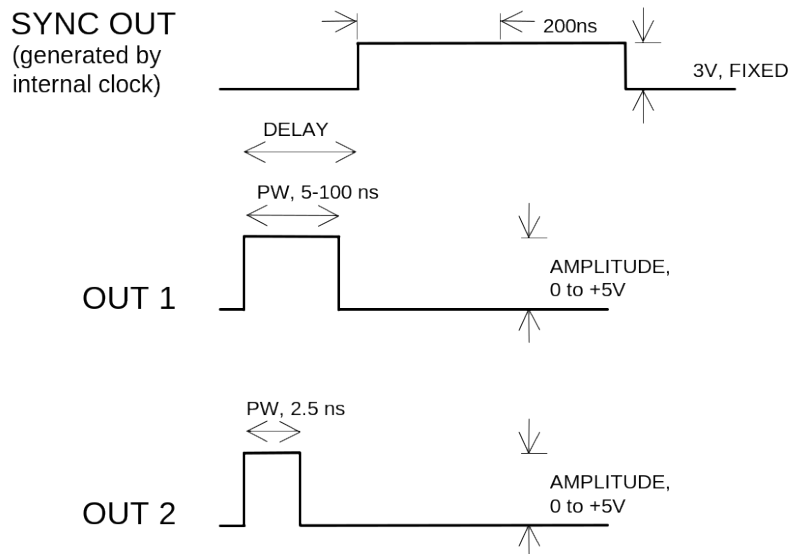

Figure B

The next figure illustrates the relationship between the signal when an external TTL-level trigger is used:

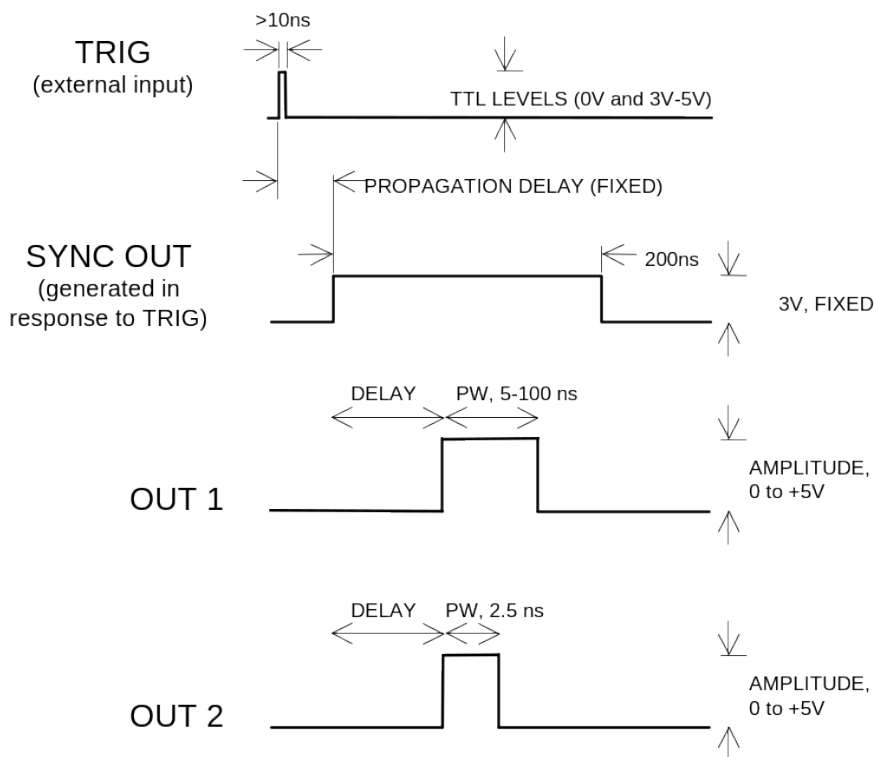

Figure C

As before, if the delay is negative, the order of the SYNC and OUT pulses is reversed.

In general, the delay, pulse width, and frequency (when in the internal mode), of the OUT pulse can be varied with front panel controls or via the GPIB or RS-232 computer interfaces.

TRIGGER MODES

This instrument has four trigger modes:

- Internal Trigger: the instrument controls the trigger frequency, and generates the clock internally.
- External Trigger: the instrument is triggered by an external TTL-level clock on the back-panel TRIG connector.
- Manual Trigger: the instrument is triggered by the front-panel "SINGLE PULSE" pushbutton.
- Hold Trigger: the instrument is set to not trigger at all.

These modes can be selected using the front panel trigger menu, or by using the appropriate programming commands. (See the "OP1B Interface Programming Manual" for more details.)

WARNING: The output stage may be damaged if triggered by an external signal at a pulse repetition frequency greater than 1 MHz.

GATING MODES

Triggering can be suppressed by a TTL-level signal on the rear-panel GATE connector. The instrument can be set to stop triggering when this input high or low, using the front-panel gate menu or the appropriate programming commands. When gated, the output will complete the full pulse width if the output is high, and then stop triggering. Pulses are not truncated.

PULSE WIDTH / AMPLITUDE INTERACTION

The pulse width and delay of the output pulse may vary slightly with the amplitude setting, particularly at lower amplitudes. For some demanding applications, it may be desirable to use external attenuators in conjunction with the AVMP-1A-B-P-FOICC, instead of generating a low-amplitude pulse directly.

OBTAINING OPTIMUM JITTER PERFORMANCE

When jitter performance is a priority, it may be necessary to adjust the delay setting within a $\pm 5\text{ns}$ range to obtain the lowest jitter, as the jitter has a slight periodic delay dependency.

TOP COVER REMOVAL

The interior of the instrument may be accessed by removing the four Phillips screws on the top panel. With the four screws removed, the top cover may be slid back (and off).

ELECTROMAGNETIC INTERFERENCE

To prevent electromagnetic interference with other equipment, all used outputs should be connected to shielded 50Ω loads using shielded 50Ω coaxial cables. Unused outputs should be terminated with shielded 50Ω BNC terminators or with shielded BNC dust caps, to prevent unintentional electromagnetic radiation. All cords and cables should be less than 3m in length.

RACK MOUNTING

A rack mounting kit is available. The -R5 rack mount kit may be installed after first removing the one Phillips screw on the side panel adjacent to the front handle.

PROTECTING YOUR INSTRUMENT

DO NOT EXCEED 1 MHz

The output stage may be damaged if triggered by an external signal at a pulse repetition frequency greater than 1 MHz.

USE A 50Ω LOAD

The output stage may be damaged if the output is not terminated into a 50Ω load.

NEVER APPLY AN EXTERNAL VOLTAGE TO THE OUTPUT

Externally generated potentials must never be applied to the output, with the exception of the OS1 and OS2 offsets (see page 9).

Failures resulting from the above factors are not covered by the warranty.

OPERATIONAL CHECK

This section describes a sequence to confirm the basic operation of the instrument. It should be performed after receiving the instrument. It is a useful learning exercise as well.

Before proceeding with this procedure, finish reading this instruction manual thoroughly. Then read the “Local Control” section of the “OP1B Interface Programming Manual” thoroughly. The “Local Control” section describes the front panel controls used in this operational check - in particular, the MOVE, CHANGE, and ADJUST controls.

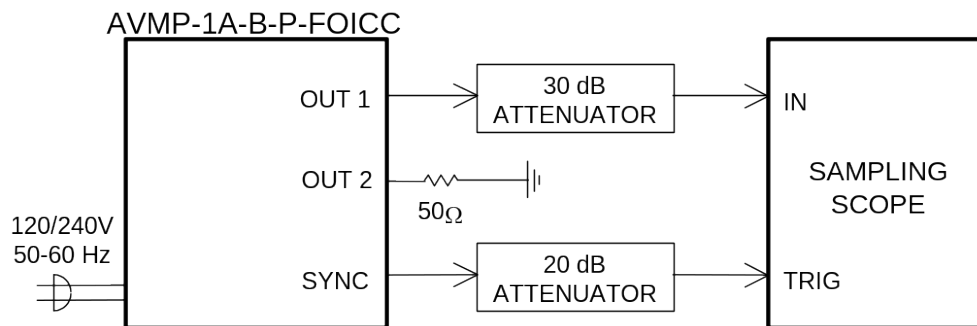

BASIC TEST ARRANGEMENT

1. Connect the pulse generator to a sampling oscilloscope as shown above. Note that:
 - a) The use of 30 dB attenuator at the sampling scope vertical input channel will insure a peak input signal to the sampling scope of less than 1 Volt.
 - b) The TRIG output channel provides TTL level signals (approximately 0 and +3V). To avoid overdriving the TRIG input channel of some scopes, a 20 dB attenuator should be placed at the input to the scope trigger channel.
 - c) The bandwidth capability of components and instruments used to display the pulse generator output signal (attenuators, cables, connectors, etc.) should exceed 10 GHz.
 - d) Set the oscilloscope to trigger externally with the vertical setting at 50 mV/div and the horizontal setting at 10 ns/div.
2. Turn on the AVMP-1A-B-P-FOICC. The main menu will appear on the LCD.

3. To set the AVMP-1A-B-P-FOICC to trigger from the internal clock at a PRF of 2 kHz:
 - a) The arrow pointer should be pointing at the frequency menu item. If it is not, press the MOVE button until it is.
 - b) Press the CHANGE button. The frequency submenu will appear. Rotate the ADJUST knob until the frequency is set at 2 kHz.
 - c) The arrow pointer should be pointing at the "Internal" choice. If it is not, press MOVE until it is.
 - d) Press CHANGE to return to the main menu.
4. To set the delay to 100 ns:
 - a) Press the MOVE button until the arrow pointer is pointing at the delay menu item.
 - b) Press the CHANGE button. The delay submenu will appear. Rotate the ADJUST knob until the delay is set at 100 ns. (Note that it may be necessary to adjust the delay setting within a ± 5 ns range to obtain optimum jitter performance, as the jitter has a slight periodic delay dependency.)
 - c) The arrow pointer should be pointing at the "Normal" choice. If it is not, press MOVE until it is.
 - d) Press CHANGE to return to the main menu.
5. To set the Channel 1 pulse width to 50 ns:
 - a) Press the MOVE button until the arrow pointer is pointing at the "PW1" menu item.
 - b) Press the CHANGE button. The pulse width submenu will appear. Rotate the ADJUST knob until the pulse width is set at 50 ns.
 - c) The arrow pointer should be pointing at the "Normal" choice. If it is not, press MOVE until it is.
 - d) Press CHANGE to return to the main menu.
6. At this point, nothing should appear on the oscilloscope.
7. To enable the output:

- a) Press the MOVE button until the arrow pointer is pointing at the output menu item.
 - b) Press the CHANGE button. The output submenu will appear.
 - c) Press MOVE until the arrow pointer is pointing at the "ON" choice.
 - d) Press CHANGE to return to the main menu.
8. To change the output amplitude:
- a) Press the MOVE button until the arrow pointer is pointing at the "AMP1" menu item.
 - b) Press the CHANGE button. The amplitude submenu will appear. Rotate the ADJUST knob until the amplitude is set at +5V.
 - c) Observe the oscilloscope. You should see 50 ns wide, +5V pulses (attenuated to approximately 150 mV by the 30 dB attenuator). If you do not, you may need to adjust the delay setting to a value more compatible with your sampling oscilloscope. You may also need to adjust the sampling scope controls.
 - d) Rotate the ADJUST knob. The amplitude as seen on the oscilloscope should vary. Return it to +5V.
 - e) Press CHANGE to return to the main menu.
9. Try varying the pulse width, by repeating step (5). As you rotate the ADJUST knob, the pulse width on the oscilloscope will change. It should agree with the displayed value.
10. Reverse the "OUT1" and "OUT2" connections, so that the OUT2 output is displayed on the sampling scope, and OUT1 is terminated with a 50 Ohm load.
11. To change the output amplitude:
- a) Press the MOVE button until the arrow pointer is pointing at the "AMP2" menu item.
 - b) Press the CHANGE button. The amplitude submenu will appear. Rotate the ADJUST knob until the amplitude is set at +5V.
 - c) Observe the oscilloscope. You should see 2.5 ns wide, +5V pulses (attenuated to approximately 150 mV by the 30 dB attenuator). If you do not, you may need to adjust the delay setting to a value more compatible with your sampling

oscilloscope. You may also need to adjust the sampling scope controls.

- d) Rotate the ADJUST knob. The amplitude as seen on the oscilloscope should vary. Return it to +5V.

12. Press CHANGE to return to the main menu.

This completes the operational check.

PROGRAMMING YOUR PULSE GENERATOR

KEY PROGRAMMING COMMANDS

The “OP1B Interface Programming Manual” describes in detail how to connect the pulse generator to your computer, and the programming commands themselves. A large number of commands are available; however, normally you will only need a few of these. Here is a basic sample sequence of commands that might be sent to the instrument after power-up:

```
*rst                (resets the instrument)
trigger:source internal (selects internal triggering)
frequency 1000 Hz    (sets the frequency to 1000 Hz)
pulse:width1 50 ns   (sets the channel 1 pulse width to 50 ns)
pulse:delay 20 ns    (sets the delay to 20 ns)
volt:amp1 +2         (sets the channel 1 amplitude to 2V)
volt:amp2 +5         (sets the channel 2 amplitude to 5V)
output on            (turns on the output)
```

For triggering a single event, this sequence would be more appropriate:

```
*rst                (resets the instrument)
trigger:source hold  (turns off all triggering)
pulse:width1 50 ns   (sets the channel 1 pulse width to 50 ns)
output on            (turns on the output)
volt:amp1 +2         (sets the channel 1 amplitude to 2V)
volt:amp2 +5         (sets the channel 2 amplitude to 5V)
trigger:source immediate (generates a single non-repetitive trigger event)
trigger:source hold  (turns off all triggering)
output off           (turns off the output)
```

To set the instrument to trigger from an external TTL signal applied to the rear-panel TRIG connector, use:

```
*rst                (resets the instrument)
trigger:source external (selects external triggering)
pulse:width1 50 ns    (sets the channel 1 pulse width to 50 ns)
pulse:delay 100 ns    (sets the delay to 100 ns)
volt:amp1 +2         (sets the channel 1 amplitude to 2V)
volt:amp2 +5         (sets the channel 2 amplitude to 5V)
output on            (turns on the output)
```

These commands will satisfy 90% of your programming needs.

ALL PROGRAMMING COMMANDS

For more advanced programmers, a complete list of the available commands is given below. These commands are described in detail in the “OP1B Interface Programming Manual”. (Note: this manual also includes some commands that are not implemented in this instrument. They can be ignored.)

Note that the amplitude commands should be suffixed with the channel number, as illustrated in the previous section. If the suffix is not included, channel 1 will be assumed. The remaining commands will generate an error if a channel suffix is attached, since their effects are common to both channels.

<u>Keyword</u>	<u>Parameter</u>	<u>Notes</u>
LOCAL		
OUTPut:		
:[STATe]	<boolean value>	
:PROTection		
:TRIPped?		[query only]
REMOTE		
[SOURce]:		
:FREQuency		
[:CW FIXed]	<numeric value>	
[SOURce]:		
:PULSe		
:PERiod	<numeric value>	
:WIDTh	<numeric value>	
:DCYCLE	<numeric value>	
:HOLD	WIDTh DCYCLE	
:DELay	<numeric value>	
:GATE		
:LEVel	High Low	
[SOURce]:		
:VOLTage		
[:LEVel]		
[:IMMediate]		
[:AMPLitude]	<numeric value>	
:PROTection		
:TRIPped?		[query only]
STATUS:		
:OPERation		
:[EVENT]?		[query only, always returns "0"]
:CONDition?		[query only, always returns "0"]
:ENABle	<numeric value>	[implemented but not useful]
:QUEStionable		
:[EVENT]?		[query only, always returns "0"]
:CONDition?		[query only, always returns "0"]
:ENABle	<numeric value>	[implemented but not useful]
SYSTEM:		
:COMMunicate		

:GPIB		
:ADDRESS	<numeric value>	
:SERIAL		
:CONTROL		
:RTS	ON IBFull RFR	
:[RECEIVE]		
:BAUD	1200 2400 4800 9600	
:BITS	7 8	
:ECHO	<boolean value>	
:PARITY		
:[TYPE]	EVEN ODD NONE	
:SBITS	1 2	
:ERROR		
:[NEXT]?		[query only]
:COUNT?		[query only]
:VERSION?		[query only]
TRIGGER:		
:SOURCE	INTERNAL EXTERNAL MANUAL HOLD IMMEDIATE	
*CLS		[no query form]
*ESE	<numeric value>	
*ESR?		[query only]
*IDN?		[query only]
*OPC		
*SAV	0 1 2 3	[no query form]
*RCL	0 1 2 3	[no query form]
*RST		[no query form]
*SRE	<numeric value>	
*STB?		[query only]
*TST?		[query only]
*WAI		[no query form]

PERFORMANCE CHECKSHEET