

INSTRUCTIONS

MODEL AVMP-4-C

0 TO 10 VOLTS, 1 MHz

HIGH SPEED PULSE GENERATOR

WITH 200 ps RISE TIME, 200 ps FALL TIME

SERIAL NUMBER: _____

WARRANTY

Avtech Electrosystems Ltd. warrants products of its manufacture to be free from defects in material and workmanship under conditions of normal use. If, within one year after delivery to the original owner, and after prepaid return by the original owner, this Avtech product is found to be defective, Avtech shall at its option repair or replace said defective item. This warranty does not apply to units which have been disassembled, modified or subjected to conditions exceeding the applicable specifications or ratings. This warranty is the extent of the obligation assumed by Avtech with respect to this product and no other warranty or guarantee is either expressed or implied.

TECHNICAL SUPPORT

Phone: 613-226-5772 or 1-800-265-6681

Fax: 613-226-2802 or 1-800-561-1970

E-mail: info@avtechpulse.com

World Wide Web: <http://www.avtechpulse.com>

TABLE OF CONTENTS

| | |
|---|-----------|
| WARRANTY | 2 |
| TECHNICAL SUPPORT | 2 |
| TABLE OF CONTENTS | 3 |
| INTRODUCTION | 4 |
| AVAILABLE OPTIONS | 4 |
| SPECIFICATIONS | 5 |
| INSTALLATION | 6 |
| VISUAL CHECK | 6 |
| PLUGGING IN THE INSTRUMENT | 6 |
| FIG. 1 : FRONT PANEL CONTROLS | 8 |
| FRONT PANEL CONTROLS | 9 |
| REAR PANEL CONTROLS (for units without -OT or -EO options) | 11 |
| REAR PANEL CONTROLS (for units with -OT or -EO options) | 13 |
| GENERAL INFORMATION | 15 |
| BASIC TEST ARRANGEMENT | 15 |
| BASIC PULSE CONTROL | 15 |
| AMPLITUDE / PULSE WIDTH INTERACTION | 16 |
| MINIMIZING WAVEFORM DISTORTIONS | 17 |
| USE 50 Ω TRANSMISSION LINES AND LOADS | 17 |
| USE LOW-INDUCTANCE LOADS | 17 |
| PREVENTING DAMAGE | 17 |
| MECHANICAL INFORMATION | 18 |
| TOP COVER REMOVAL | 18 |
| ELECTROMAGNETIC INTERFERENCE | 18 |
| POWER SUPPLY AND FUSE REPLACEMENT | 19 |
| PERFORMANCE CHECK SHEET | 21 |

INTRODUCTION

The AVPP-2-C is a high performance instrument capable of generating up to 10V into 50 Ω loads at repetition rates up to 1 MHz. The output pulse width is variable from 10 ns to 10 μ s (10% max duty cycle). The rise time is less than 200 ps, and the fall time is 200 ps.

Instruments with the "-P" model suffix can generate 0 to +10V, whereas instruments with the "-N" model suffix can generate 0 to -10V.

Instruments with the "-PN" suffix generate 0 to \pm 10V at the main output, and the output polarity is controlled by a front panel two position switch.

The output is designed to drive 50 Ω loads. (A 50 Ω load is required for proper operation.) The output is AC-coupled.

AVAILABLE OPTIONS

The AVMP-4-C is available with several options:

"-OT" Option: this option adds an internally-generated 0 to \pm 5V DC offset to the main output.

"-EO" Option: the DC offset can be controlled by an externally generated 0 to +10V analog control voltage.

"-EA" Option: the amplitude can be controlled by an externally generated 0 to +10V analog control voltage.

"-EW" Option: the pulse width can be controlled by an externally generated 0 to +10V analog control voltage.

"-M" Option: a monitor output is provided.

SPECIFICATIONS

| | |
|--|--|
| Model: | AVMP-4-C ¹ |
| Amplitude ³ : (50 Ohm load) | Variable to 10 Volts |
| Pulse width ³ : | Variable 10 ns to 10 μ s in 3 ranges (10% max duty cycle) |
| PRF: external trigger mode: internal trigger: | 0 to 1 MHz 100 Hz to 1 MHz |
| Rise and fall times: | $t_{RISE} \leq 200$ ps, $t_{FALL} \leq 200$ ps |
| Polarity ⁴ : | Positive or negative or both (specify) |
| Propagation delay: | ≤ 30 ns (Ext trig in to pulse out) |
| Jitter: | ± 15 ps |
| DC offset or bias insertion ^{3,5} : | Apply required DC offset to back panel solder terminals (± 50 Volts, 250 mA max) |
| Trigger required: | Ext trig mode: +5 Volts, 10 ns or wider (TTL) |
| Sync delay: | Sync out to pulse out: Variable 0 to 200 ns |
| Sync output: | +3 Volts, 200 ns, will drive 50 Ohm loads |
| Monitor output option ⁶ : | Provides a 20 dB attenuated coincident replica of main output |
| Connectors: | Out: SMA, Trig: BNC, Sync: BNC, Monitor: SMA |
| Power requirements: | 120/240 Volts (switchable) 50-60 Hz |
| Dimensions: (H x W x D) | -P or -N units: 100 mm x 215 mm x 375 mm (3.9" x 8.5" x 14.8") -PN Units: 100 mm x 430 mm x 375 mm (3.9" x 17" x 14.8") |
| Chassis material: | cast aluminum frame & handles, blue vinyl on aluminum cover plates |
| Mounting, temperature range: | Any, +10°C to +40°C |

- 1) -C suffix indicates stand-alone lab instrument with internal clock and line powering.
- 2) -B suffix indicates IEEE-488.2 GPIB and RS-232 control of amplitude, pulse width, PRF and delay.
- 3) For analog electronic control (0 to +10V) of amplitude, pulse width, or offset, suffix model number with -EA, -EW, or -EO.
Electronic control units also include standard front-panel controls. -EW not available on -B units.
- 4) Indicate desired polarity by suffixing model number with -P or -N (i.e. positive or negative) or -PN for the dual polarity option where the polarity is controlled by a front panel two position switch.
- 5) Add -OT to model number for internally generated 0 to ± 5 V offset option.
- 6) Add -M to model number for monitor option.

INSTALLATION

VISUAL CHECK

After unpacking the instrument, examine to ensure that it has not been damaged in shipment. Visually inspect all connectors, knobs, and handles. Confirm that a power cord is with the instrument. If the instrument has been damaged, file a claim immediately with the company that transported the instrument.

PLUGGING IN THE INSTRUMENT

Examine the rear of the instrument. There will be a male power receptacle, a fuse holder and the edge of the power selector card visible. Confirm that the power selector card is in the correct orientation.

For AC line voltages of 110-120V, the power selector card should be installed so that the "120" marking is visible from the rear of the instrument, as shown below:

For AC line voltages of 220-240V, the power selector card should be installed so that the "240" marking is visible from the rear of the instrument, as shown below:

If it is not set for the proper voltage, remove the fuse and then grasp the card with a pair of pliers and remove it. Rotate horizontally through 180 degrees. Reinstall the card and the correct fuse.

In the 120V setting, a 0.5A slow blow fuse is required. In the 240V setting, a 0.25A slow blow fuse is required.

FIG. 1 : FRONT PANEL CONTROLS

FRONT PANEL CONTROLS

1. POWER Switch. The POWER push button switch applies AC prime power to the primaries of the transformer, turning the instrument on. The push button lamp is connected to the internal +15V DC supply.
2. PRF Range Switch. This switch sets the pulse repetition frequency (PRF) range of the internal oscillator. The marked value of each position is the upper limit of the 10:1 range, approximately. The vernier dial directly below the switch varies the PRF within the set range.

If this switched is set to the "EXT" position, the instrument is triggered by a TTL level signal applied to the TRIG connector, rather than by the internal oscillator (PW > 50 ns)

CAUTION. The output duty cycle must not exceed 10%.

3. TRIG Connector. When the PRF Range Switch is set to one of the four internal oscillator ranges, this connector is an output, which supplies a 2V, 200 ns wide pulse for each trigger event. This output may be used to trigger oscilloscopes or other equipment.

When the PRF Range Switch is set to "EXT", the instrument is triggered by a TTL pulse applied to this connector. The pulse must be at least 50 ns wide.

4. Delay Controls. These controls vary the relative delay between reference output pulse provided at the TRIG output (3) and the main output (8). This delay is variable over the range of 0 to about 500 ns. Coarse and fine controls are provided. If the Advance/Delay switch (5) is set to "ADVANCE", the reference output on the TRIG output (3) precedes the main output (8). If the Advance/Delay switch is set to "DELAY", the reference output on the TRIG output (3) lags the main output (8).

The delay is not adjustable when triggering externally.

5. Pulse Width Controls. This dial and three position range switch combination controls the pulse width as follows:
 - 10 ns to 100 ns
 - 100 ns to 1 μ s
 - 1 μ s to 10 μ s

CAUTION. The output duty cycle must not exceed 10%.

6. A) Amplitude Control. This dial controls the pulse amplitude (10 Volts max).
6. B) Polarity Control. This two position switch controls the polarity of the output pulse.

7. Offset Control. (Present on -OT and -EO units only). This controls the internally-generated offset feature. The rear-panel “OFFSET ON/OFF” switch must be set to “ON” for this feature to be enabled.
7. OUT Connector. This is the main output. (This output *requires* a 50Ω load to function properly). Note that the output is AC coupled.
8. OVERLOAD Indicator. When the instrument is powered, this indicator is normally green, indicating normal operation. If this indicator is yellow, an internal automatic overload protection circuit has been tripped. If the unit is overloaded (by operation at an exceedingly high duty cycle or by operating into a very low impedance), the protective circuit will disable the output of the instrument and turn the indicator light yellow. The light will stay yellow (i.e. output disabled) for about 5 seconds after which the instrument will attempt to re-enable the output (i.e. light green) for about 1 second. If the overload condition persists, the output will be disabled again (i.e. light yellow) for another 5 seconds. If the overload condition has been removed, the instrument will resume normal operation.

This overload indicator may flash yellow briefly at start-up. This is not a cause for concern.

Overload conditions may be removed by:

- Reducing repetition rate
- Reducing pulse width
- Reducing the output amplitude

REAR PANEL CONTROLS (for units without -OT or -EO options)

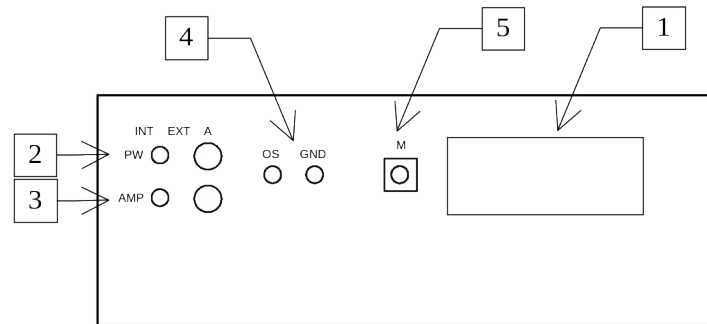

1. AC POWER INPUT. A three-pronged recessed male connector is provided on the back panel for AC power connection to the instrument. Also contained in this assembly is a slow-blow fuse and a removable card that can be removed and repositioned to switch between 120V AC in and 240V AC in.

For AC line voltages of 110-120V, the power selector card should be installed so that the “120” marking is visible from the rear of the instrument.

For AC line voltages of 220-240V, the power selector card should be installed so that the “240” marking is visible from the rear of the instrument.

If it is not set for the proper voltage, remove the fuse and then grasp the card with a pair of pliers and remove it. Rotate horizontally through 180 degrees. Reinstall the card and the correct fuse.

In the 120V setting, a 0.5A slow blow fuse is required. In the 240V setting, a 0.25A slow blow fuse is required. See the “Installation” section for more details.

2. PW INT/EXT SWITCH AND CONNECTOR (Optional, -EW units only). To control the pulse width of the output with an external DC voltage, set the two-position switch to the EXT position and apply 0 to +10V to the BNC Connector ($R_{IN} \geq 10 \text{ k}\Omega$). When this switch is in the “INT” position, the pulse width is controlled by the front-panel controls.
3. AMP INT/EXT SWITCH AND CONNECTOR (Optional, -EA units only). To control the amplitude of the output with an external DC voltage, set the two-position switch to the EXT position and apply 0 to +10V to the BNC Connector ($R_{IN} \geq 10 \text{ k}\Omega$). When this switch is in the “INT” position, the amplitude is controlled by the front-panel controls.
4. OS INPUT. To add a DC offset the output pulse, connect a DC power supply set to the desired offset value to these terminals. The maximum allowable DC offset

voltage is ± 50 Volts. When not used, this input should be connected to the adjacent ground terminal.

5. MONITOR Outputs (Optional, -M units only). Provides an attenuated ($\div 10$) coincident replica (to 50 Ohms) of the main output.

REAR PANEL CONTROLS (for units with -OT or -EO options)

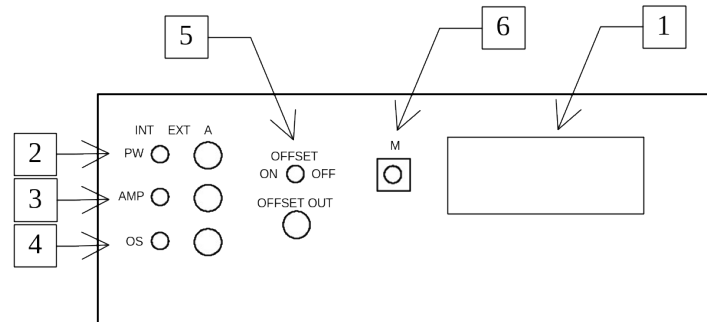

1. AC POWER INPUT. A three-pronged recessed male connector is provided on the back panel for AC power connection to the instrument. Also contained in this assembly is a slow-blow fuse and a removable card that can be removed and repositioned to switch between 120V AC in and 240V AC in.

For AC line voltages of 110-120V, the power selector card should be installed so that the “120” marking is visible from the rear of the instrument.

For AC line voltages of 220-240V, the power selector card should be installed so that the “240” marking is visible from the rear of the instrument.

If it is not set for the proper voltage, remove the fuse and then grasp the card with a pair of pliers and remove it. Rotate horizontally through 180 degrees. Reinstall the card and the correct fuse.

In the 120V setting, a 0.5A slow blow fuse is required. In the 240V setting, a 0.25A slow blow fuse is required. See the “Installation” section for more details.

2. PW INT/EXT SWITCH AND CONNECTOR (Optional, -EW units only). To control the pulse width of the output with an external DC voltage, set the two-position switch to the EXT position and apply 0 to +10V to the BNC Connector ($R_{IN} \geq 10 \text{ k}\Omega$). When this switch is in the “INT” position, the pulse width is controlled by the front-panel controls.
3. AMP INT/EXT SWITCH AND CONNECTOR (Optional, -EA units only). To control the amplitude of the output with an external DC voltage, set the two-position switch to the EXT position and apply 0 to +10V to the BNC Connector ($R_{IN} \geq 10 \text{ k}\Omega$). When this switch is in the “INT” position, the amplitude is controlled by the front-panel controls.

4. OS INT/EXT SWITCH AND CONNECTOR (Optional, -EO units only). To control the offset of the output with an external DC voltage, set the two-position switch to the EXT position and apply 0 to +10V to the BNC Connector ($R_{IN} \geq 10 \text{ k}\Omega$). When this switch is in the "INT" position, the offset is controlled by the front-panel controls.
5. OFFSET ON/OFF SWITCH & OUTPUT (Optional, -EO and -OT units only). This switch enables the offset feature when it is set to "ON". When it is set to "OFF", no offset is added to the output. The internally generated offset is available at the "OFFSET OUT" BNC connector, for monitoring purposes.
6. MONITOR Outputs (Optional, -M units only). Provides an attenuated (± 10) coincident replica (to 50 Ohms) of the main output.

GENERAL INFORMATION

BASIC TEST ARRANGEMENT

The AVMP-4-C should be tested with a sampling oscilloscope with a bandwidth of at least 10 GHz to properly observe the high-speed waveform. A typical test arrangement is shown below:

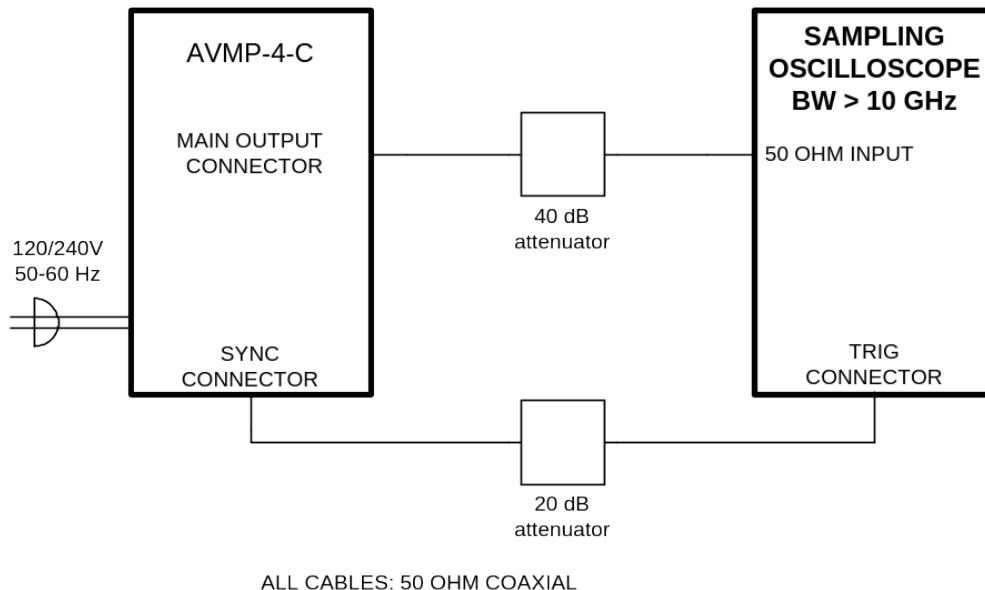

The attenuators are required to prevent damage to the sampling oscilloscope. A 40 dB attenuator with sufficient voltage rating should be used on the main output.

BASIC PULSE CONTROL

This instrument can be triggered by its own internal clock or by an external TTL trigger signal. When triggered internally, two mainframe output channels respond to the trigger: OUT and SYNC.

- OUT. This is the main output. The maximum output voltage is 10V.
- TRIG. The TRIG pulse is a 200 ns wide TTL-level reference pulse used to trigger oscilloscopes or other measurement systems.

These pulses are illustrated below:

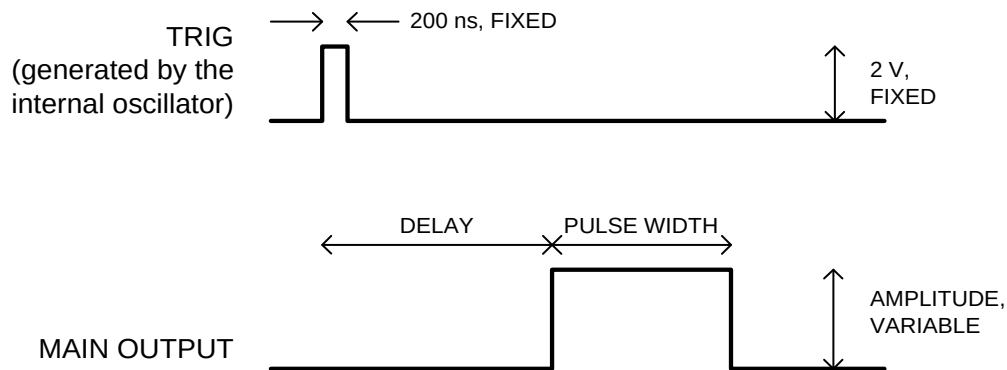

Figure A

When triggered externally, the TRIG connector acts as an input. The delay controls do not function in this mode. Figure B illustrates this mode:

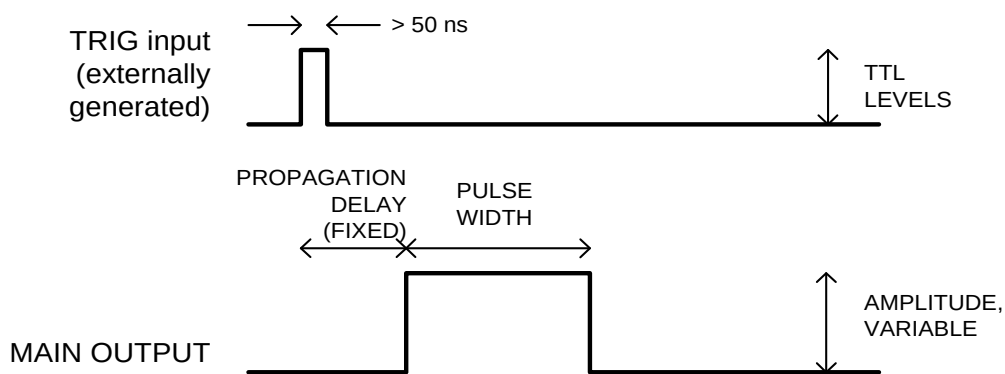

Figure B

AMPLITUDE / PULSE WIDTH INTERACTION

The output pulse amplitude is controlled by means of the front panel one-turn AMP control. The pulse width may change by several nanoseconds as the output amplitude is reduced from maximum to minimum. Therefore it is convenient to first set the desired amplitude and then set the desired pulse width. Rotation of the PW control causes the position of the falling edge of the pulse to change.

Some properties of the output pulse may change as a function of the amplitude pot setting. For some demanding applications, it may be desirable to use a combination of external attenuators and the amplitude control to achieve the desired output amplitude.

MINIMIZING WAVEFORM DISTORTIONS

USE 50Ω TRANSMISSION LINES AND LOADS

Connect the load to the pulse generator with 50Ω transmission lines (e.g. RG-58 or RG-174 cable).

This instrument requires a 50Ω load for proper operation. It will not properly drive a high-impedance load. The output stage will be damaged if it is operated into an open circuit (or any other high impedance). Failures due to improper output loading are not covered by the warranty.

USE LOW-INDUCTANCE LOADS

Lenz's Law predicts that for an inductive voltage spike will be generated when the current through an inductance changes. Specifically, $V_{\text{SPIKE}} = L \times di_{\text{LOAD}}/dt$, where L is the inductance, i_{LOAD} is the load current change, and t is time. For this reason, it is important to keep any parasitic in the load low. This means keeping wiring short, and using low inductance components. In particular, wire-wound resistors should be avoided.

PREVENTING DAMAGE

The AVMP-4-C may fail if triggered at a PRF greater than 1 MHz or a duty cycle higher than 10%.

This unit is designed to operate into a load impedance of 50 Ohms and the output stage will be damaged if it is operated into an open circuit (or any other high impedance). Failures due to improper output loading are not covered by the warranty.

MECHANICAL INFORMATION

TOP COVER REMOVAL

The interior of the instrument may be accessed by removing the four Phillips screws on the top panel. With the four screws removed, the top cover may be slid back (and off).

ELECTROMAGNETIC INTERFERENCE

To prevent electromagnetic interference with other equipment, all used outputs should be connected to shielded 50Ω loads using shielded 50Ω coaxial cables. Unused outputs should be terminated with shielded 50Ω BNC terminators or with shielded BNC dust caps, to prevent unintentional electromagnetic radiation. All cords and cables should be less than 3m in length.

POWER SUPPLY AND FUSE REPLACEMENT

This instrument has three main fuses, plus two spares. One, which protects the AC input, is located in the rear-panel power entry module, as described in the “Rear Panel Controls” section of this manual. If the power appears to have failed, check the AC fuse first.

The other two fuses (plus two spares) are located on the internal DC power supply, as shown below:

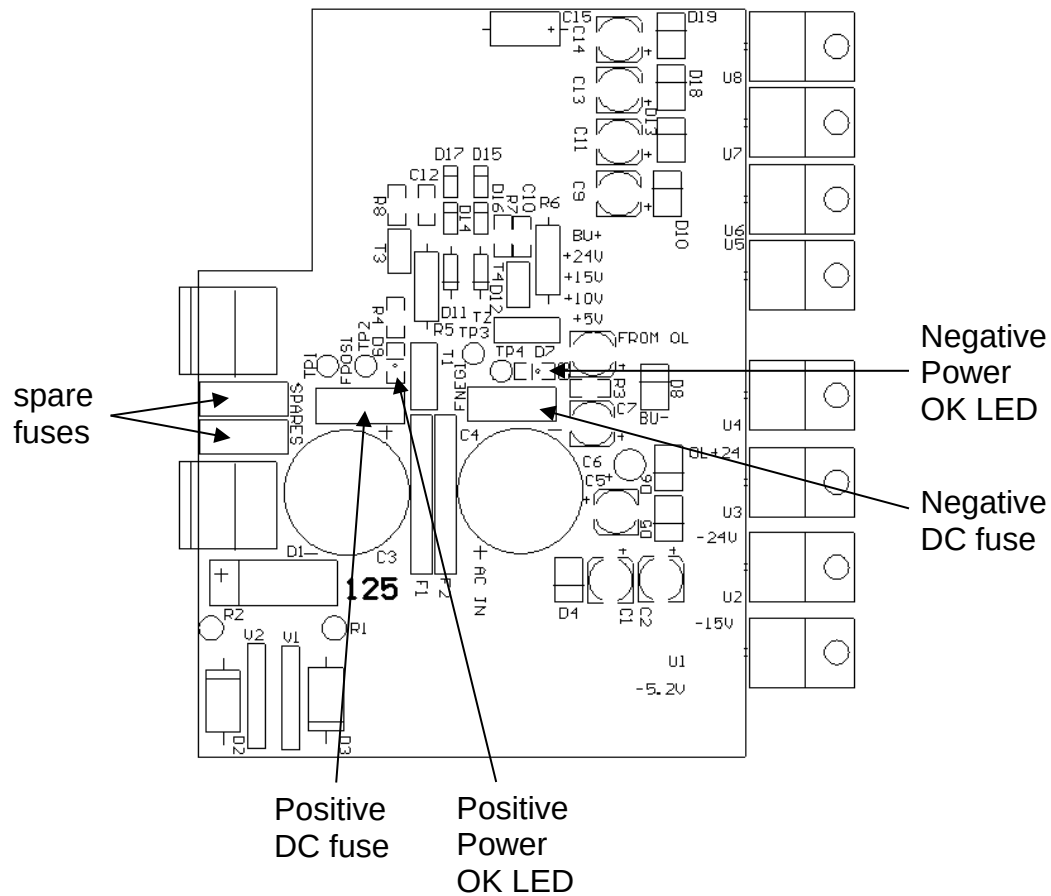

The positive fuse and one of the spare fuses on this circuit board are 1A slow-blow fuses, Littlefuse part number R452001. (This fuse can be ordered from Digikey, www.digikey.com. The Digikey part number is F1343CT-ND). The negative fuse and the second spare fuse are 0.5A slow-blow fuses (Littlefuse R452.500, Digikey part number F1341CT-ND).

If you suspect that the DC fuses are blown, follow this procedure:

1. Remove the top cover, by removing the four Phillips screws on the top cover and then sliding the cover back and off.

2. Locate the two “Power OK” LEDs on the power supply circuit board, as illustrated above.
3. Turn on the instrument.
4. Observe the “Power OK” LEDs. If the fuses are not blown, the two LEDs will be lit (bright red). If one of the LEDs is not lit, the fuse next to it has blown.
5. Turn off the instrument.
6. If a fuse is blown, use needle-nose pliers to remove the blown fuse from its surface-mount holder.
7. Replace the fuse. (Spare 1 Amp and 0.5 Amp fuses are provided on the circuit board. They may be transferred to the active fuse locations using needle-nose pliers.)

PERFORMANCE CHECK SHEET