



AVTECH ELECTROSYSTEMS LTD.

NANOSECOND WAVEFORM ELECTRONICS
SINCE 1975

P.O. BOX 265
OGDENSBURG, NY
U.S.A. 13669-0265
TEL: (315) 472-5270
FAX: (613) 226-2802

TEL: 1-800-265-6681
FAX: 1-800-561-1970

e-mail: info@avtechpulse.com
<http://www.avtechpulse.com/>

BOX 5120, LCD MERIVALE
OTTAWA, ONTARIO
CANADA K2C 3H4
TEL: (613) 226-5772
FAX: (613) 226-2802

INSTRUCTIONS

MODEL AVMP-4-C

0 TO 10 VOLTS, 1 MHz

HIGH SPEED PULSE GENERATOR

WITH 200 ps RISE TIME, 200 ps FALL TIME

SERIAL NUMBER: _____

WARRANTY

Avtech Electrosystems Ltd. warrants products of its manufacture to be free from defects in material and workmanship under conditions of normal use. If, within one year after delivery to the original owner, and after prepaid return by the original owner, this Avtech product is found to be defective, Avtech shall at its option repair or replace said defective item. This warranty does not apply to units which have been disassembled, modified or subjected to conditions exceeding the applicable specifications or ratings. This warranty is the extent of the obligation assumed by Avtech with respect to this product and no other warranty or guarantee is either expressed or implied.

TECHNICAL SUPPORT

Phone: 613-226-5772 or 1-800-265-6681

Fax: 613-226-2802 or 1-800-561-1970

E-mail: info@avtechpulse.com

World Wide Web: <http://www.avtechpulse.com>

TABLE OF CONTENTS

WARRANTY.....	2
TECHNICAL SUPPORT.....	2
TABLE OF CONTENTS.....	3
INTRODUCTION.....	4
AVAILABLE OPTIONS.....	4
SPECIFICATIONS.....	5
INSTALLATION.....	6
VISUAL CHECK.....	6
PLUGGING IN THE INSTRUMENT.....	6
FRONT PANEL CONTROLS.....	8
REAR PANEL CONTROLS.....	10
GENERAL INFORMATION.....	12
BASIC TEST ARRANGEMENT.....	12
BASIC PULSE CONTROL.....	12
AMPLITUDE / PULSE WIDTH INTERACTION.....	13
MINIMIZING WAVEFORM DISTORTIONS.....	14
USE 50Ω TRANSMISSION LINES AND LOADS.....	14
USE LOW-INDUCTANCE LOADS.....	14
PREVENTING DAMAGE.....	14
MECHANICAL INFORMATION.....	15
TOP COVER REMOVAL.....	15
ELECTROMAGNETIC INTERFERENCE.....	15
POWER SUPPLY AND FUSE REPLACEMENT.....	16
MAINTENANCE.....	18
REGULAR MAINTENANCE.....	18
CLEANING.....	18
PERFORMANCE CHECK SHEET.....	19

INTRODUCTION

The AVMP-4-C is a high performance instrument capable of generating up to 10V into 50 Ω loads at repetition rates up to 1 MHz. The rise time and fall times are less than 200 ps. The pulse width is variable from 10 ns to 10 us, and the maximum duty cycle is 10%.

Instruments with the "-P" model suffix can generate 0 to +10V, whereas instruments with the "-N" model suffix can generate 0 to -10V. Instruments with the "-PN" suffix can generate both polarities.

The output is designed to drive 50 Ω loads. (A 50 Ω load is required for proper operation.) The output is AC-coupled.

This instrument is intended for use in research and development laboratories.

AVAILABLE OPTIONS

The AVMP-4-C is available with several options:

-EA Option: the output amplitude can be controlled by an externally generated 0 to +10V analog control voltage.

-ECL Option: the input trigger levels are ECL, rather than TTL.

-EW Option: the output pulse width can be controlled by an externally generated 0 to +10V analog control voltage.

-M Option: a monitor output is provided.

SPECIFICATIONS

Model:	AVMP-4-C ¹
Amplitude ³ : (50 Ohm load)	0 to 10 Volts
Pulse width ⁴ :	10 ns to 10 us
PRF:	0 to 1 MHz
Duty cycle (max):	10 %
Rise time:	≤ 200 ps
Fall time:	≤ 200 ps
Polarity ⁵ :	Positive or negative or both (specify)
Propagation delay:	≤ 30 ns
Jitter	±15 ps (Ext trig in to pulse out)
Trigger required:	external trigger mode: +5 Volts, 10 ns or wider (TTL)
Sync delay:	Variable to ± 10 us
Sync output:	+5 Volts, 200 ns, will drive 50 Ohm loads
Monitor output option ⁷ :	Provides a 20 dB attenuated coincident replica of main output
Dimensions (H x W x D):	100 x 215 x 375 mm (3.9 x 8.5 x 14.8")
Connectors:	Out: SMA, Trig: BNC, Sync : BNC, Monitor: SMA
Power requirement:	120/240 Volts (switchable) 50-60 Hz
Chassis material:	anodized aluminum, with blue plastic trim
Mounting, Temperature range:	Any, +10° to +40° C

- 1) -C suffix indicates stand-alone lab instrument with internal clock and line powering. No suffix indicates miniature module requiring DC power and external trigger. (See page 112 for additional details of the four basic instrument formats).
- 3,4,6) For electronic control (0 to +10V) of amplitude, pulse width, or offset, suffix model number with -EA or -EW or -EO. Electronic control units also include standard front-panel one-turn controls. -EW not available on -B units.
- 5) Indicate desired polarity by suffixing model number by -P or -N (i.e. positive or negative) or -P-PN or -N-PN for dual polarity option where the suffix preceding -PN indicates the polarity at the mainframe output port (for -1A, -2 and -3 units). For AVMP-4-C units polarity control is by a two-position switch (keypad polarity control for AVMP-4-B units).
- 7) For monitor option add suffix -M.

INSTALLATION

VISUAL CHECK

After unpacking the instrument, examine to ensure that it has not been damaged in shipment. Visually inspect all connectors, knobs, and handles. Confirm that a power cord is with the instrument. If the instrument has been damaged, file a claim immediately with the company that transported the instrument.

PLUGGING IN THE INSTRUMENT

Examine the rear of the instrument. There will be a male power receptacle, a fuse holder and the edge of the power selector card visible. Confirm that the power selector card is in the correct orientation.

For AC line voltages of 110-120V, the power selector card should be installed so that the “120” marking is visible from the rear of the instrument, as shown below:



For AC line voltages of 220-240V, the power selector card should be installed so that the “240” marking is visible from the rear of the instrument, as shown below:



If it is not set for the proper voltage, remove the fuse and then grasp the card with a pair of pliers and remove it. Rotate horizontally through 180 degrees. Reinstall the card and the correct fuse.

In the 120V setting, a 0.5A slow blow fuse is required. In the 240V setting, a 0.25A slow blow fuse is required.

FRONT PANEL CONTROLS

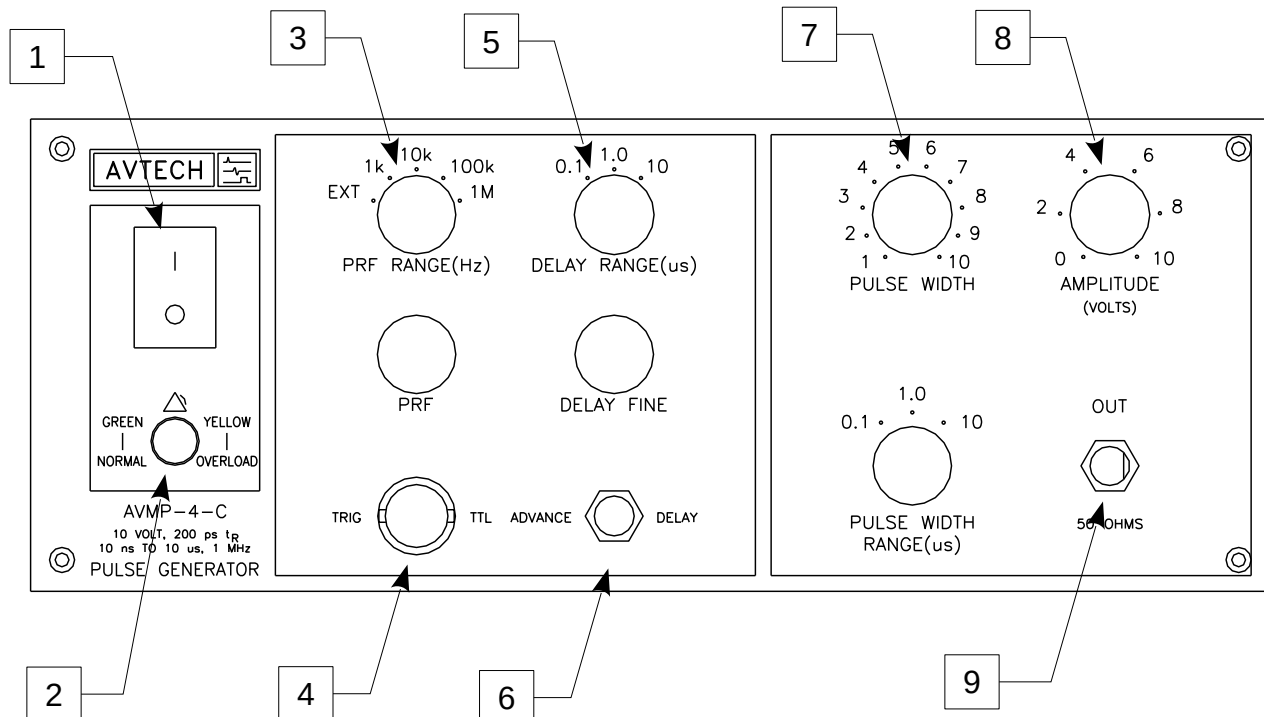

- 1) POWER Switch. This is the main power switch. When turning the instrument on, there may be a delay of several seconds before the instrument appears to respond.
- 2) OVERLOAD Indicator. When the instrument is powered, this indicator is normally green, indicating normal operation. If this indicator is yellow, an internal automatic overload protection circuit has been tripped. If the unit is overloaded (by operating at an exceedingly high duty cycle or by operating into a very low impedance), the protective circuit will disable the output of the instrument and turn the indicator light yellow. The light will stay yellow (i.e. output disabled) for about 5 seconds after which the instrument will attempt to re-enable the output (i.e. light green) for about 1 second. If the overload condition persists, the output will be disabled again (i.e. light yellow) for another 5 seconds. If the overload condition has been removed, the instrument will resume normal operation.

This overload indicator may flash yellow briefly at start-up. This is not a cause for concern.

- 3) PRF Switch and Vernier. This switch sets the pulse repetition frequency (PRF) range of the internal oscillator. The marked value of each position is the upper limit of the 10:1 range, approximately. The vernier dial directly below the switch varies the PRF within the set range.

If this switched is set to the “EXT” position, the instrument is triggered by a signal applied to the TRIG connector, rather than by the internal oscillator.

The maximum duty cycle of the AVMP-4-C is 10%. Take care not to exceed this limit, or the instrument may be damaged.

- 4) TRIG Connector. When the PRF Range Switch is set to “EXT”, the instrument is triggered by a TTL pulse applied to this connector. The pulse must be at least 50 ns wide.

When the PRF Range Switch is set to one of the four internal oscillator ranges, this connector is an output, which supplies a 2V, 200 ns wide pulse for each trigger event. This output may be used to trigger oscilloscopes or other equipment.

- 5) DELAY Switch and Vernier. When the PRF Range Switch is set to one of the four internal oscillator ranges, the main output is advanced or delayed relative to the TRIG output pulse. This switch sets the delay range. The marked value of each position is the upper limit of the 10:1 range, approximately. The vernier dial directly below the switch varies the delay within the set range.
- 6) ADVANCE/DELAY Switch. When the PRF Range Switch is set to one of the four internal oscillator ranges, this switch determines whether the TRIG output precedes the main output (ADVANCE mode), or whether the TRIG output occur after the main output (DELAY mode).
- 7) PULSE WIDTH Switch and Vernier. This switch sets the pulse width range. The marked value of each position is the upper limit of the 10:1 range, approximately. The vernier dial directly above the switch varies the pulse width within the set range.

The maximum duty cycle of the AVMP-4-C is 10%. Take care not to exceed this limit, or the instrument may be damaged.

- 8) Amplitude Control. This dial controls the pulse amplitude.
- 9) OUT Connector. This SMA connector provides the main output. This output *requires* a 50Ω load to function properly

REAR PANEL CONTROLS

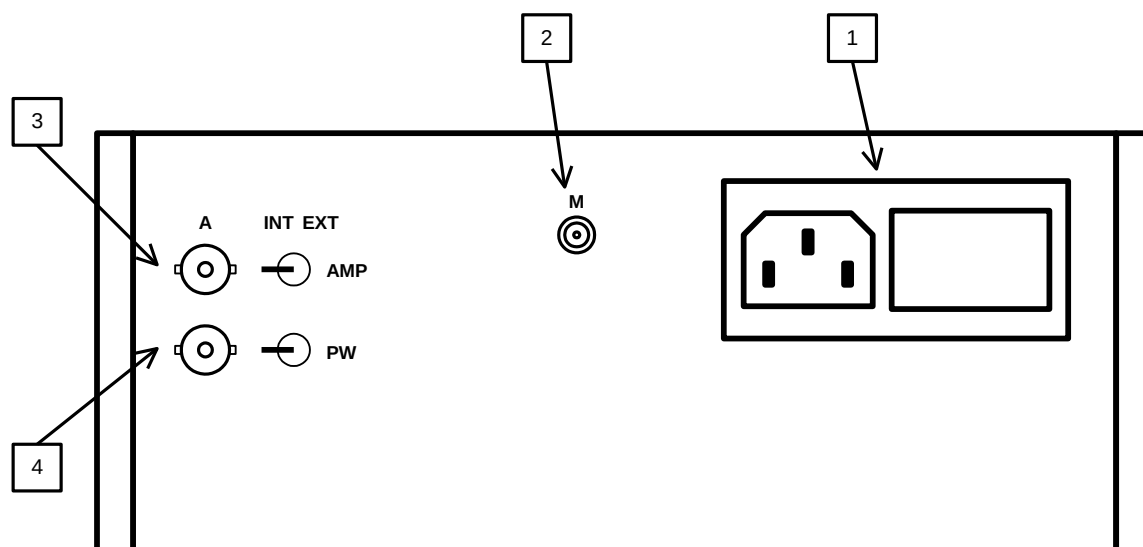

1. AC POWER INPUT. A three-pronged recessed male connector is provided on the back panel for AC power connection to the instrument. Also contained in this assembly is a slow-blow fuse and a removable card that can be removed and repositioned to switch between 120V AC in and 240V AC in.

For AC line voltages of 110-120V, the power selector card should be installed so that the “120” marking is visible from the rear of the instrument.

For AC line voltages of 220-240V, the power selector card should be installed so that the “240” marking is visible from the rear of the instrument.

If it is not set for the proper voltage, remove the fuse and then grasp the card with a pair of pliers and remove it. Rotate horizontally through 180 degrees. Reinstall the card and the correct fuse.

In the 120V setting, a 0.5A slow blow fuse is required. In the 240V setting, a 0.25A slow blow fuse is required. See the “Installation” section for more details.

2. M OUTPUT CONNECTOR. (Present on units with -M option only.) This SMA connector output provides a 20 dB attenuated coincident replica of main output, for monitoring purposes.
3. AMP SWITCH & INPUT. (Present on units with -EA option only.) To control the output amplitude with an external voltage, set the rear-panel switch to the “EXT” position and apply 0 to +10V to the adjacent connector ($R_{IN} \geq 10k\Omega$).

4. PW SWITCH & INPUT. (Present on units with -EW option only.) To control the output pulse width with an external voltage, set the rear-panel switch to the "EXT" position and apply 0 to +10V to the adjacent connector ($R_{IN} \geq 10k\Omega$).

GENERAL INFORMATION

BASIC TEST ARRANGEMENT

The AVMP-4-C should be tested with a sampling oscilloscope with a bandwidth of at least 10 GHz to properly observe the high-speed waveform. A typical test arrangement is shown below:

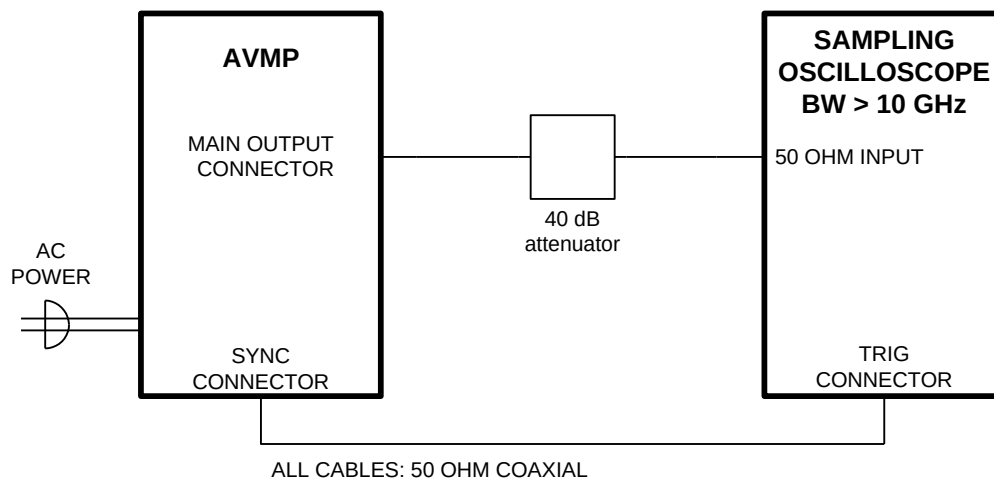

The attenuators are required to prevent damage to the sampling oscilloscope. A 40 dB attenuator with sufficient voltage rating should be used on the main output.

The maximum duty cycle of the AVMP-4-C is 10%. Take care not to exceed this limit, or the instrument may be damaged.

BASIC PULSE CONTROL

This instrument can be triggered by its own internal clock or by an external TTL trigger signal. When triggered internally, two mainframe output channels respond to the trigger: OUT and SYNC.

- OUT. This is the main output. The maximum output voltage is 10V.
- TRIG. The TRIG pulse is a 200 ns wide TTL-level reference pulse used to trigger oscilloscopes or other measurement systems.

These pulses are illustrated below:

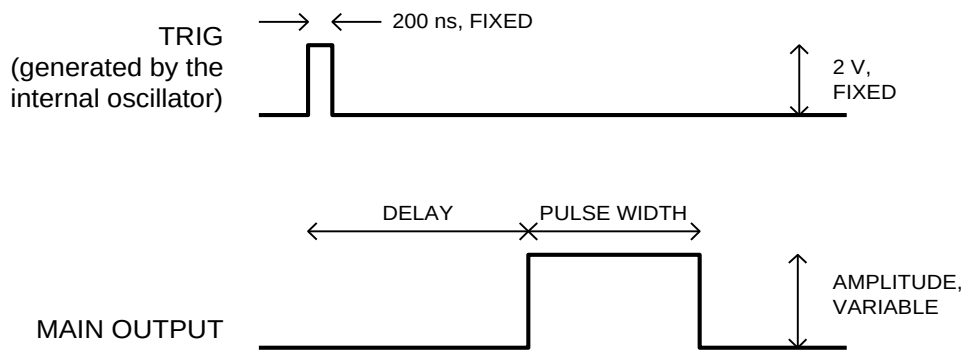

Figure A

When triggered externally, the TRIG connector acts as an input. The delay controls do not function in this mode. Figure B illustrates this mode:

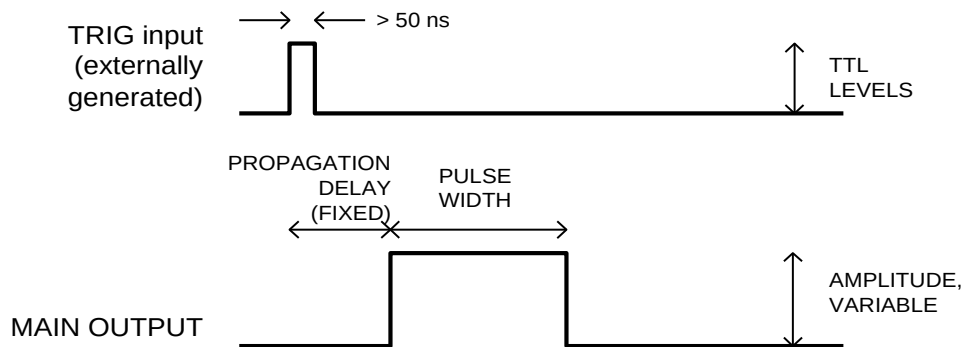

Figure B

The maximum duty cycle of the AVMP-4-C is 10%. Take care not to exceed this limit, or the instrument may be damaged.

AMPLITUDE / PULSE WIDTH INTERACTION

The output pulse amplitude is controlled by means of the front panel one-turn AMP control. The pulse width may change by several nanoseconds as the output amplitude is reduced from maximum to minimum. Therefore it is convenient to first set the desired amplitude and then set the desired pulse width. Rotation of the PW control causes the position of the falling edge of the pulse to change.

Some properties of the output pulse may change as a function of the amplitude pot setting. For some demanding applications, it may be desirable to use a combination of external attenuators and the amplitude control to achieve the desired output amplitude.

MINIMIZING WAVEFORM DISTORTIONS

USE 50Ω TRANSMISSION LINES AND LOADS

Connect the load to the pulse generator with 50Ω transmission lines (e.g. RG-58 or RG-174 cable).

This instrument requires a 50Ω load for proper operation. It will not properly drive a high-impedance load. The output stage will be damaged if it is operated into an open circuit (or any other high impedance). Failures due to improper output loading are not covered by the warranty.

USE LOW-INDUCTANCE LOADS

Lenz's Law predicts that for an inductive voltage spike will be generated when the current through an inductance changes. Specifically, $V_{\text{SPIKE}} = L \times di_{\text{LOAD}}/dt$, where L is the inductance, i_{LOAD} is the load current change, and t is time. For this reason, it is important to keep any parasitic in the load low. This means keeping wiring short, and using low inductance components. In particular, wire-wound resistors should be avoided.

PREVENTING DAMAGE

The AVMP-4-C may fail if triggered at a PRF greater than 1 MHz.

The maximum duty cycle of the AVMP-4-C is 10%. Take care not to exceed this limit, or the instrument may be damaged.

This unit is designed to operate into a load impedance of 50 Ohms and the output stage will be damaged if it is operated into an open circuit (or any other high impedance). Failures due to improper output loading are not covered by the warranty.

The lifetime of the switching elements in the pulse generator module is proportional to the running time of the instrument. For this reason the prime power to the instrument should be turned off when the instrument is not in use.

MECHANICAL INFORMATION

TOP COVER REMOVAL

If necessary, the interior of the instrument may be accessed by removing the four Phillips screws on the top panel. With the four screws removed, the top cover may be slid back (and off).

Always disconnect the power cord before opening the instrument.

There are no user-adjustable internal circuits. For repairs other than fuse replacement, please contact Avtech (info@avtechpulse.com) to arrange for the instrument to be returned to the factory for repair.

⚠ Caution: High voltages are present inside the instrument during normal operation. Do not operate the instrument with the cover removed.

ELECTROMAGNETIC INTERFERENCE

To prevent electromagnetic interference with other equipment, all used outputs should be connected to shielded 50Ω loads using shielded 50Ω coaxial cables. Unused outputs should be terminated with shielded 50Ω coaxial terminators or with shielded coaxial dust caps, to prevent unintentional electromagnetic radiation. All cords and cables should be less than 3m in length.

POWER SUPPLY AND FUSE REPLACEMENT

This instrument has three main fuses, plus two spares. One, which protects the AC input, is located in the rear-panel power entry module, as described in the “Rear Panel Controls” section of this manual. If the power appears to have failed, check the AC fuse first.

The other two fuses (plus two spares) are located on the internal DC power supply, as shown below:

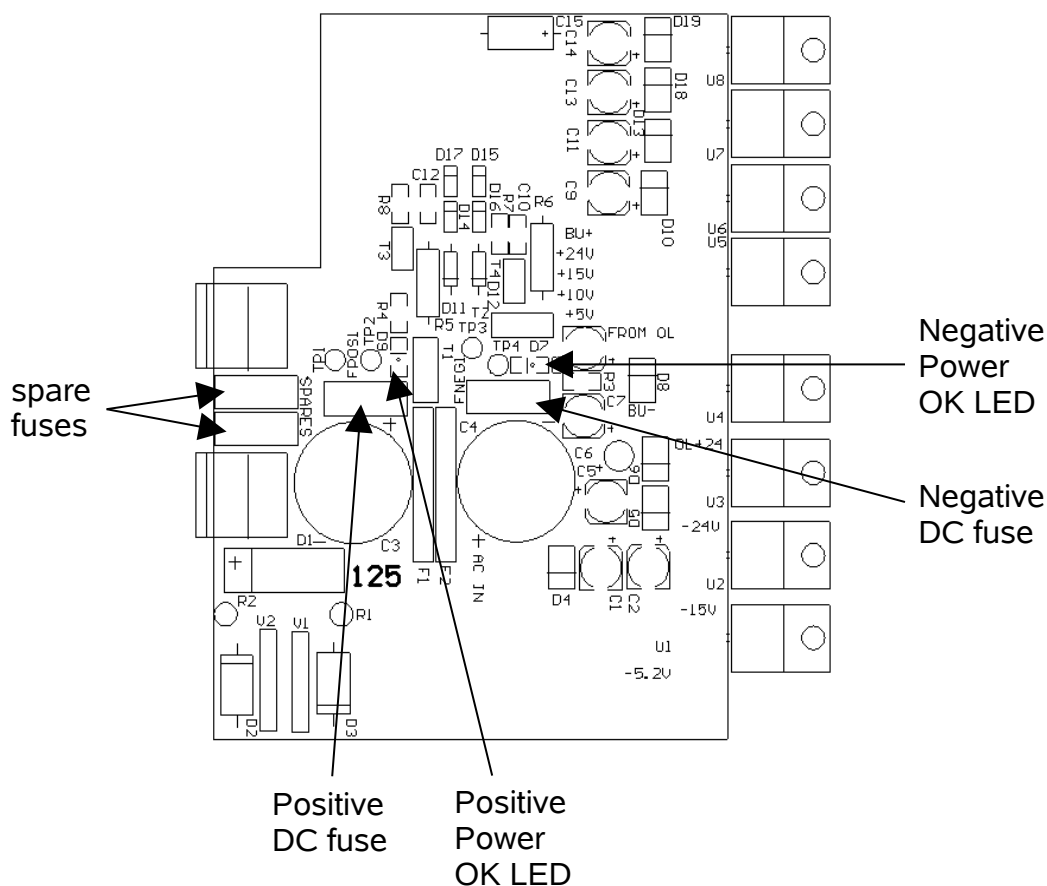

The four fuses on this circuit board are 0.5A slow-blow fuses, Littlefuse part number R452.500. (This fuse can be ordered from Digikey, www.digikey.com. The Digikey part number is F1341CT-ND).

If you suspect that the DC fuses are blown, follow this procedure:

1. Remove the top cover, by removing the four Phillips screws on the top cover and then sliding the cover back and off.
2. Locate the two “Power OK” LEDs on the power supply circuit board, as illustrated above.

3. Turn on the instrument.
4. Observe the “Power OK” LEDs. If the fuses are not blown, the two LEDs will be lit (bright red). If one of the LEDs is not lit, the fuse next to it has blown.
5. Turn off the instrument.
6. If a fuse is blown, use needle-nose pliers to remove the blown fuse from its surface-mount holder.
7. Replace the fuse. (Two spare 0.5 Amp fuses are provided on the circuit board. They may be transferred to the active fuse locations using needle-nose pliers.)

MAINTENANCE

REGULAR MAINTENANCE

This instrument does not require any regular maintenance.

CLEANING

If desired, the interior of the instrument may be cleaned using compressed air to dislodge any accumulated dust. (See the “TOP COVER REMOVAL” section for instructions on accessing the interior.) No other cleaning is recommended.

PERFORMANCE CHECK SHEET