

INSTRUCTIONS

MODEL AVO-2L-C-GL2 LASER DIODE DRIVER

S.N.: 9764

MODEL AVX-S3A-GL1 BIAS INSERTION UNIT

S.N.: 9765

### WARRANTY

Avtech Electrosystems Ltd. warrants products of its manufacture to be free from defects in material and workmanship under conditions of normal use. If, within one year after delivery to the original owner, and after prepaid return by the original owner, this Avtech product is found to be defective, Avtech shall at its option repair or replace said defective item. This warranty does not apply to units which have been disassembled, modified or subjected to conditions exceeding the applicable specifications or ratings. This warranty is the extent of the obligation assumed by Avtech with respect to this product and no other warranty or guarantee is either expressed or implied.

### TECHNICAL SUPPORT

Phone: 613-226-5772 or 1-800-265-6681

Fax: 613-226-2802 or 1-800-561-1970

E-mail: [info@avtechpulse.com](mailto:info@avtechpulse.com)

World Wide Web: <http://www.avtechpulse.com>

TABLE OF CONTENTS

WARRANTY.....2

TABLE OF CONTENTS.....3

FIG. 1: PULSE GENERATOR TEST ARRANGEMENT.....4

GENERAL OPERATING INSTRUCTIONS.....5

FIG. 2: PULSE GENERATOR TEST ARRANGEMENT (WITH AVX-S3A  
MODULE).....8

GENERAL OPERATING INSTRUCTIONS.....9

FUNCTIONAL EQUIVALENT CCT.....10

FIG. 3: FRONT PANEL CONTROLS.....11

FRONT PANEL CONTROLS.....12

FIG. 4: BACK PANEL CONTROLS.....13

BACK PANEL CONTROLS.....14

POWER SUPPLY AND FUSE REPLACEMENT.....15

ORIGINAL QUOTATIONS.....17

PERFORMANCE CHECK SHEET.....19

**FIG. 1: PULSE GENERATOR TEST ARRANGEMENT  
(WITH AVO-2L-T)**

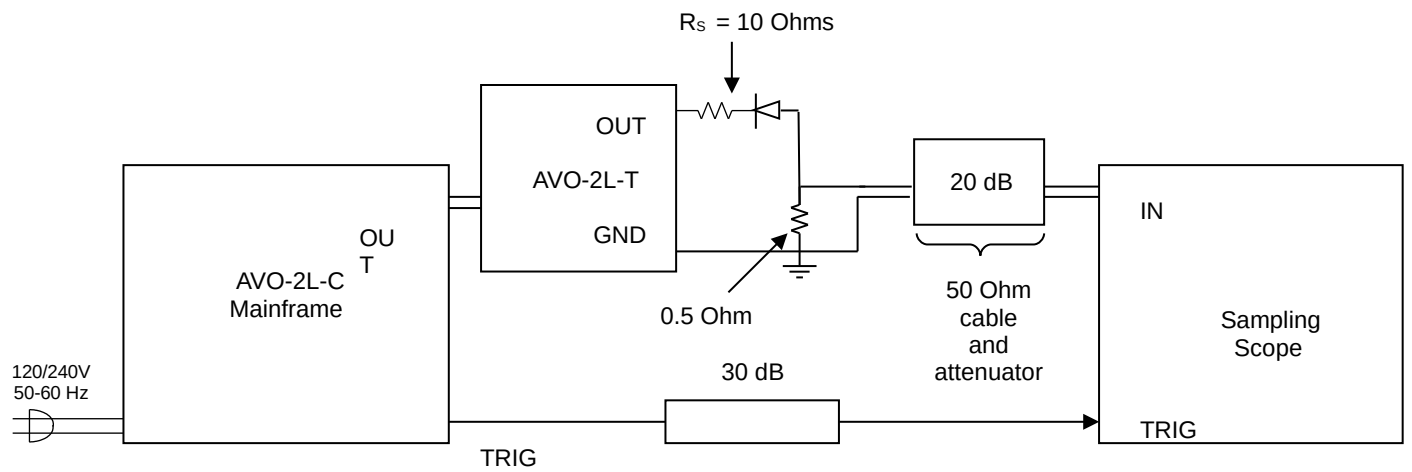

## GENERAL OPERATING INSTRUCTIONS

- 1) The bandwidth capability of components and instruments used to display the pulse generator output signal (attenuators, cables, connectors, etc.) should exceed two gigahertz.
- 2) The use of 20-dB attenuator at the sampling scope vertical input channel will insure a peak input signal to the sampling scope of less than one Volt.
- 3) The TRIG output channel provides TTL level signals. To avoid overdriving the TRIG input channel of some scopes, a 30 dB attenuator should be placed at the input to the scope trigger channel. The TRIG output precedes the main output when the front panel ADVANCE-DELAY switch is in the ADVANCE position. The TRIG output lags the main output when the switch is in the DELAY position.
- 4) To obtain a stable output display the PRF control on the front panel should be set mid-range while the PRF switch may be in either range. The front panel PRF range switch should be in mid range. The front panel DELAY controls and the scope triggering controls are then adjusted to obtain a stable output. The scope may then be used to set the desired PRF by rotating the PRF controls.
- 5) The output pulse width is controlled by means of the front panel one-turn PW control. The control should initially be set maximum clockwise and the pulse width adjusted using an oscilloscope.
- 6) The output pulse amplitude is controlled by means of the front panel one-turn AMP control.
- 7) The AVO-2L-T module connects to the AVO mainframe via a 2-foot long miniature coaxial cable. The AVO-2L-T module transforms the AVO mainframe output to 20 Volts to 10 Ohm. The laser diode is connected in series with a current limiting resistor ( $R_S = 5 \text{ Ohm}$ ) between the GND and OUT terminals on the AVO-2L-T. 1/4 watt carbon film or carbon composition resistors may be used but all leads must be as short as possible (< 0.1 inch). Solder leads directly to the GND and OUT terminals.  
CAUTION: Use moderate heat when soldering to the OUT terminal.

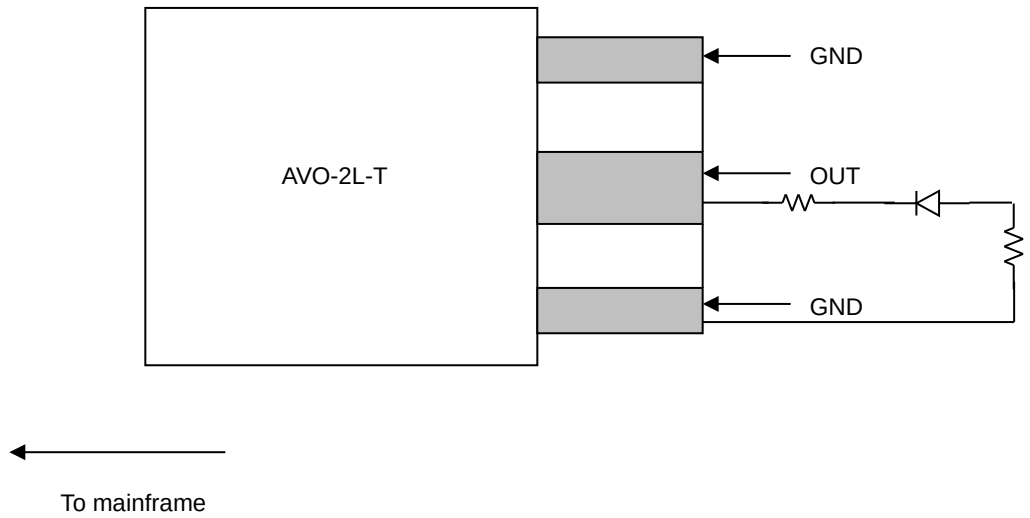

- 8) The amplitude of the diode current is determined primarily by the setting of the front panel AMP pot control, and to a lesser extent by the limiting resistor  $R_S$  and by the series resistance of the laser diode. The performance check results given in the following page were obtained using a 1N459A diode to simulate a laser diode load. With this diode a peak current of 2 Amperes was obtained with  $R_S = 10$  Ohm and the pot set maximum clockwise.
- 9) An external clock may be used to control the output PRF of the AVO unit by setting the front panel PRF range switch in the EXT position and applying a 50 ns (or wider) TTL level pulse to the TRIG BNC connector input. For operation in this mode, the scope time base must also be triggered in the external clock. The propagation delay time in the externally triggered mode is about 300 ns.
- 10) The unit can be converted from 120 to 240V 50-60 Hz operation by adjusting the voltage selector card in the rear panel fused voltage selector-cable connector assembly.
- 11) For additional assistance:
- Tel: (613) 226-5772  
Fax: (613) 226-2802  
Email: [info@avtechpulse.com](mailto:info@avtechpulse.com)

FIG. 2: PULSE GENERATOR TEST ARRANGEMENT (WITH AVX-S3A MODULE)

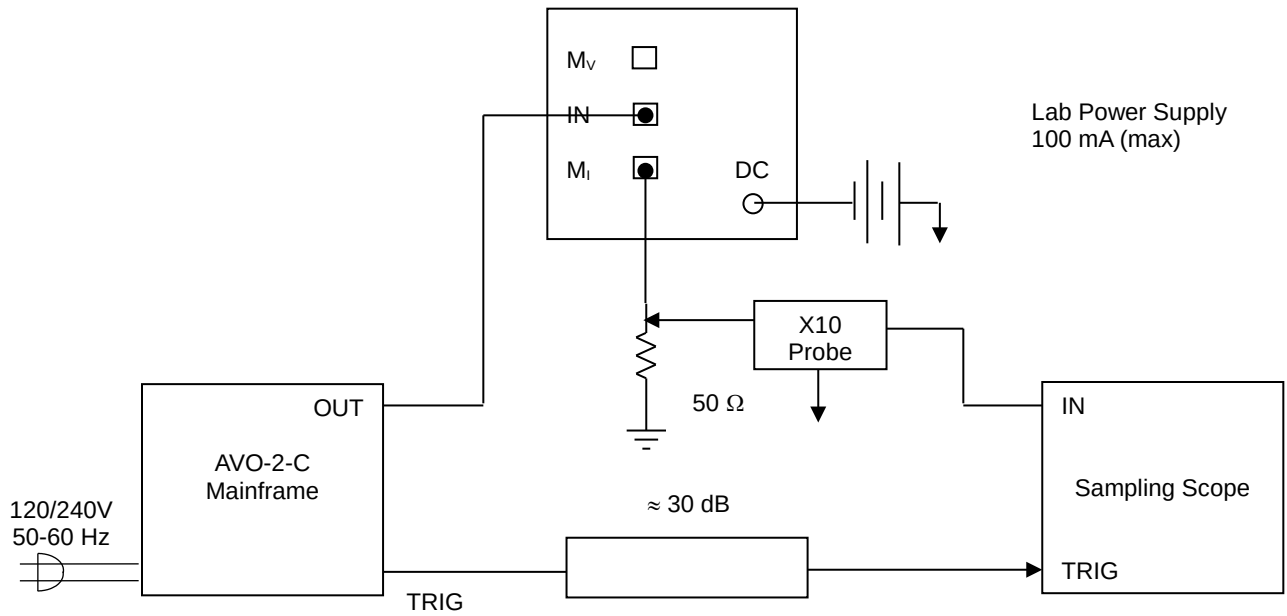



## GENERAL OPERATING INSTRUCTIONS

- 1) Remove the AVO-2L-T module from the mainframe and connect the AVX-S3A in its place.
- 2) Gently insert the leads of the TO-3 package into the openings of the pin socket. Push the leads fully into the socket.
- 3) The DC terminal of the bias insertion must either be shorted to ground (if a DC offset is not require) or not function if the DC terminal is open circuited. Note that the DC current must not exceed -100 mA (applying a DC potential of 0 to -5 Volts is normally adequate).
- 4) The MI port must be terminated into 50 Ohms. Note that a 30 dB attenuator may be placed between the AVX-S3A MI output and the scope input.
- 5) The pulsed diode current  $I_D$  (Amps) and the MI output voltage (Volts) are related as follows:

$$I_D = 11 \frac{(V_{MI} - V_{DIODE})}{10}$$

$V_{DIODE}$  is the "ON" voltage and may be obtained from the diode data sheet.  $V_{MI}$  is the voltage at the  $M_I$  SMA output. Note that this unit will provide peak output currents as high as 2.0 Amps.

- 6) The  $M_V$  port may be used to monitor the pulsed diode "ON" voltage ( $V_{DIODE}$  - pulse):

$$V_{DIODE} - \text{pulse} = 11 V_{MV}$$

$V_{MV}$  is the voltage at the  $M_V$  SMA output (to 50 Ohms).

- 7) The 9-Pin female D connector (Norcomp Part No. 172-009-201-001, Digi-Key Part No. 109F-ND) provides direct connections to pins 1, 2, 3 & 8 of the TO-3 package as follows:

<u>D Connector</u> <u>Pin No.</u>	<u>TO-3</u> <u>Pin No.</u>
1	1
2	2
3	3
8	8

### FUNCTIONAL EQUIVALENT CCT

### FUNCTIONAL EQUIVALENT CCT

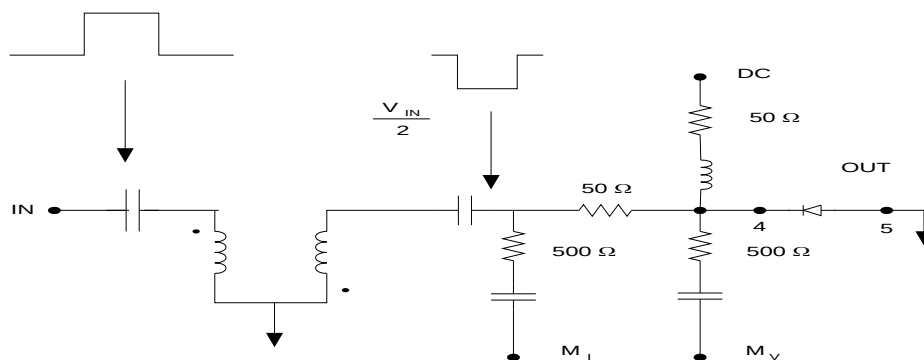

3.0"

1.6"

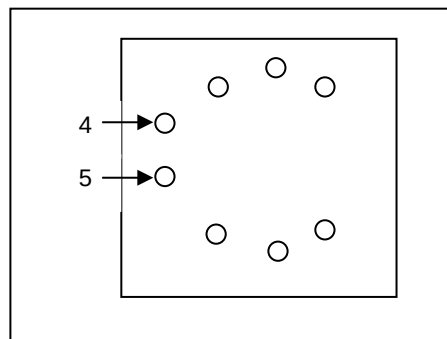
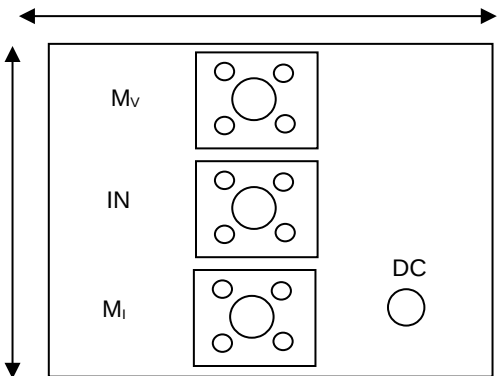

### PACKAGE

FIG. 3: FRONT PANEL CONTROLS

## FRONT PANEL CONTROLS

- (1) ON-OFF Switch. This is the main power switch. It applies basic prime power to all stages.
- (2) PRF Control. With this range switch in the 20, 200, 2K or 20K positions, the pulse repetition frequency (PRF) of the instrument is controlled by the internal clock oscillator, which in turn is controlled by the PRF range switch and fine control.

With the range switch in the EXT position, the instrument requires a 50 ns (or wider) TTL level pulse applied at the TRIG input in order to trigger the output stages.

- (3) DELAY Control. These controls vary the relative delay between the reference output pulse provided at the TRIG output (4) and the main output (6). This delay is variable over the range of 0 to about 500 ns. Coarse and fine controls are provided. If the Advance/Delay switch (5) is set to "ADVANCE", the reference output on the TRIG output (4) precedes the main output (6). If the Advance/Delay switch (5) is set to "DELAY", the reference output on the TRIG output (4) lags the main output (6).

The delay is not adjustable when triggering externally.

- (4) TRIG Connector. This connector has two functions. When triggered internally, this output provides a reference signal that can be used to trigger an oscilloscope scope time base. The output is a 2V, 200 ns (approx.) pulse capable of driving a 50-Ohm load. Set the scope to trigger on the positive edge.

When triggered externally (i.e., the PRF range switch is in the EXT position), the external TTL-level trigger signal is applied at this point.

- (5) ADVANCE/DELAY SWITCH. This switch determines whether the reference output pulse on the TRIG connector (4) occurs in before the main output pulse (ADVANCE mode), or whether the reference pulse occurs after the main output pulse (DELAY mode). This switch is only useful when triggering internally.
- (6) OUT Connector. SMA connector provides output to the AVO-2-T module.
- (7) PULSE WIDTH. A one-turn control which varies the output pulse width.
- (8) AMP Control. A one-turn control which varies the output pulse amplitude.

FIG. 4: BACK PANEL CONTROLS

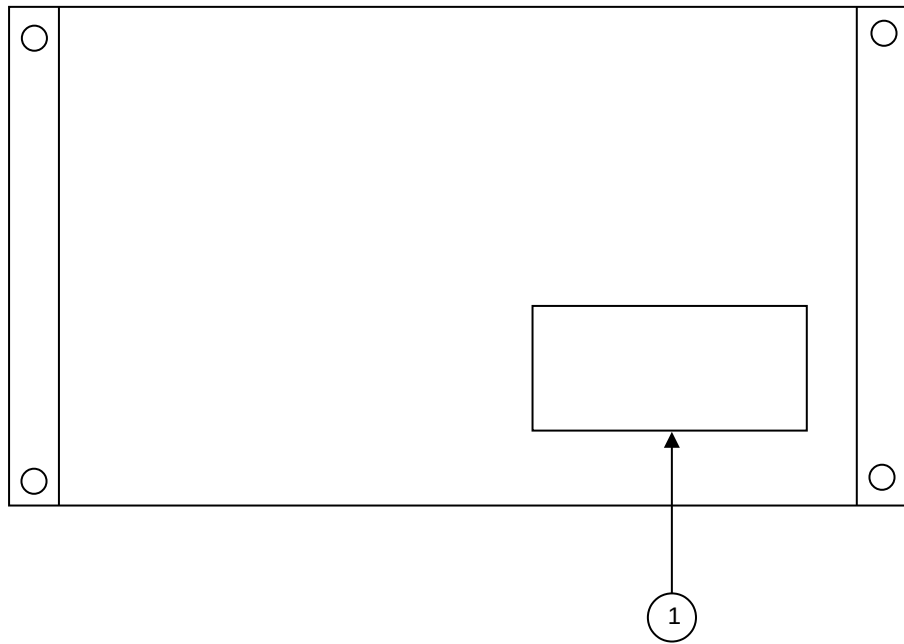

## BACK PANEL CONTROLS

- (1) FUSED CONNECTOR, VOLTAGE SELECTOR. The detachable power cord is connected at this point. In addition, the removable cord is adjusted to select the desired input operating voltage. The unit also contains the main power fuse.

For AC line voltages of 110-120V, the power selector card should be installed so that the "120" marking is visible from the rear of the instrument.

For AC line voltages of 220-240V, the power selector card should be installed so that the "240" marking is visible from the rear of the instrument.

If it is not set for the proper voltage, remove the fuse and then grasp the card with a pair of pliers and remove it. Rotate horizontally through 180 degrees. Reinstall the card and the correct fuse.

In the 120V setting, a 0.5A slow blow fuse is required. In the 240V setting, a 0.25A slow blow fuse is required.

## POWER SUPPLY AND FUSE REPLACEMENT

This instrument has three fuses (plus one spare). One, which protects the AC input, is located in the rear-panel power entry module, as described in the “Rear Panel Controls” section of this manual. If the power appears to have failed, check the AC fuse first.

The other two fuses (plus one spare) are located on the internal DC power supply, as shown below:

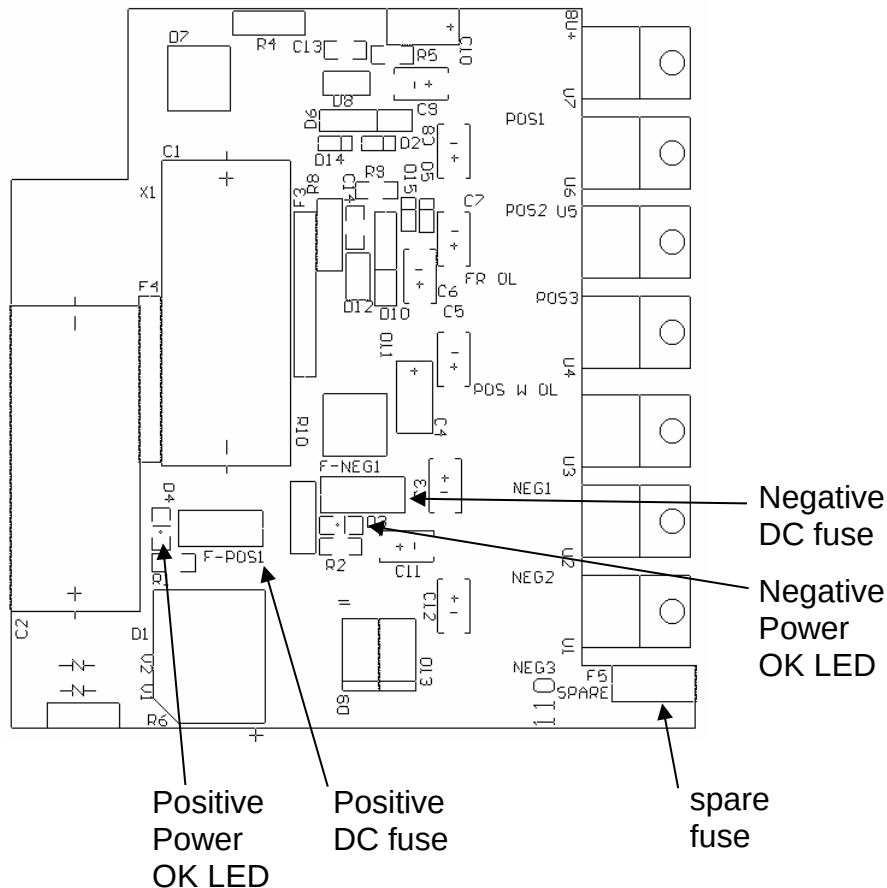

The spare fuse may be used to replace one of the other fuses, if required.

The three fuses on this circuit board are 0.5A slow-blow fuses, Littlefuse part number R452.500. (This fuse can be ordered from Digikey, [www.digikey.com](http://www.digikey.com). The Digikey part number is F1341CT-ND).

If you suspect that the DC fuses are blown, follow this procedure:

1. Remove the top cover, by removing the four Phillips screws on the top cover and then sliding the cover back and off.
2. Locate the two "Power OK" LEDs on the power supply circuit board, as illustrated above.
3. Turn on the instrument.
4. Observe the "Power OK" LEDs. If the fuses are not blown, the two LEDs will be lit (bright red). If one of the LEDs is not lit, the fuse next to it has blown.
5. Turn off the instrument.
6. If a fuse is blown, use needle-nose pliers to remove the blown fuse from its surface-mount holder.
7. Replace the fuse.



ORIGINAL QUOTATIONS



PERFORMANCE CHECK SHEET