



AVTECH ELECTROSYSTEMS LTD.

NANOSECOND WAVEFORM ELECTRONICS
SINCE 1975

P.O. BOX 265
OGDENSBURG, NY
U.S.A. 13669-0265
TEL: (315) 472-5270
FAX: (315) 883-1328

TEL: 1-800-265-6681
FAX: 1-800-561-1970

e-mail: info@avtechpulse.com
<http://www.avtechpulse.com/>

BOX 5120, LCD MERIVALE
OTTAWA, ONTARIO
CANADA K2C 3H4
TEL: (613) 226-5772
FAX: (613) 226-2802

INSTRUCTIONS

MODEL AVO-2W-B-P-M-LT5

0-10 Amp, 1-50 ns
30 kHz LASER DIODE DRIVER
WITH IEEE 488.2 AND RS-232 CONTROL

SERIAL NUMBER: _____

WARRANTY

Avtech Electrosystems Ltd. warrants products of its manufacture to be free from defects in material and workmanship under conditions of normal use. If, within one year after delivery to the original owner, and after prepaid return by the original owner, this Avtech product is found to be defective, Avtech shall at its option repair or replace said defective item. This warranty does not apply to units which have been disassembled, modified or subjected to conditions exceeding the applicable specifications or ratings. This warranty is the extent of the obligation assumed by Avtech with respect to this product and no other warranty or guarantee is either expressed or implied.

TECHNICAL SUPPORT

Phone: 613-226-5772 or 1-800-265-6681

Fax: 613-226-2802 or 1-800-561-1970

E-mail: info@avtechpulse.com

World Wide Web: <http://www.avtechpulse.com>

TABLE OF CONTENTS

WARRANTY.....	2
TECHNICAL SUPPORT.....	2
TABLE OF CONTENTS.....	3
INTRODUCTION.....	5
SPECIFICATIONS.....	6
ORIGINAL QUOTATION.....	7
EUROPEAN REGULATORY NOTES.....	9
EC DECLARATION OF CONFORMITY.....	9
DIRECTIVE 2002/95/EC (RoHS).....	9
DIRECTIVE 2002/96/EC (WEEE).....	9
INSTALLATION.....	11
VISUAL CHECK.....	11
POWER RATINGS.....	11
CONNECTION TO THE POWER SUPPLY.....	11
PROTECTION FROM ELECTRIC SHOCK.....	12
ENVIRONMENTAL CONDITIONS.....	12
LABVIEW DRIVERS.....	13
FUSES.....	14
AC FUSE REPLACEMENT.....	14
DC FUSE REPLACEMENT.....	15
FUSE RATINGS.....	15
FRONT PANEL CONTROLS.....	16
REAR PANEL CONTROLS.....	18
GENERAL INFORMATION.....	20
INSTALLING THE DEVICE UNDER TEST.....	20
BASIC TEST ARRANGEMENT & FUNCTIONAL EQUIVALENT CIRCUIT.....	21
THERMAL CONTROL.....	22
BASIC PULSE CONTROL.....	23
TRIGGER MODES.....	24
GATING MODES.....	25
PROTECTING YOUR INSTRUMENT.....	26
TURN OFF INSTRUMENT WHEN NOT IN USE.....	26
DO NOT EXCEED 30 kHz.....	26

OPERATIONAL CHECK.....	27
PROGRAMMING YOUR PULSE GENERATOR.....	30
KEY PROGRAMMING COMMANDS.....	30
ALL PROGRAMMING COMMANDS.....	31
MECHANICAL INFORMATION.....	33
TOP COVER REMOVAL.....	33
RACK MOUNTING.....	33
ELECTROMAGNETIC INTERFERENCE.....	33
MAINTENANCE.....	34
REGULAR MAINTENANCE.....	34
CLEANING.....	34
WIRING DIAGRAMS.....	35
WIRING OF AC POWER.....	35
PCB 158K - LOW VOLTAGE POWER SUPPLY, 1/3.....	36
PCB 158K - LOW VOLTAGE POWER SUPPLY, 2/3.....	37
PCB 158K - LOW VOLTAGE POWER SUPPLY, 3/3.....	38
PCB 168B - HIGH VOLTAGE DC POWER SUPPLY.....	39
PCB 104D - KEYPAD / DISPLAY BOARD, 1/3.....	40
PCB 104D - KEYPAD / DISPLAY BOARD, 2/3.....	41
PCB 104D - KEYPAD / DISPLAY BOARD, 3/3.....	42
PCB 101B - DRIVE SIGNAL BOARD.....	43
MAIN WIRING.....	44
PERFORMANCE CHECKSHEET.....	45

Manual Reference: /files/server1/officefiles/instructword/avo-2/AVO-2W-B-P-M-LT5,ed1.odt.

Last modified February 29, 2024.

Copyright © 2024 Avtech Electrosystems Ltd, All Rights Reserved.

INTRODUCTION

The AVO-2W-B-P-M-LT5 is a high performance, GPIB and RS232-equipped instrument capable of generating amplitudes of up to 10 A at repetition rates up to 30 kHz. The pulse width is variable from 1 to 50 ns. The rise and fall times are less than 1 ns for pulse widths below 4 ns, and less than 2 ns for wider pulses. The AVO-2W-B-P-M-LT5 includes an internal trigger source, but it can also be triggered or gated by an external source. A front-panel push-button can also be used to trigger the instrument.

The AVO-2W-B-P-M-LT5 features front panel keyboard and adjust knob control of the output pulse parameters along with a four line by 40-character back-lit LCD display of the output amplitude, pulse width, pulse repetition frequency, and delay. The instrument includes memory to store up to four complete instrument setups. The operator may use the front panel or the computer interface to store a complete “snapshot” of all key instrument settings, and recall this setup at a later time.

The AVO-2W-B-P-M-LT5 must be used in conjunction with the separately-ordered AVX-S1-HC-P1-LT5 output module. Together, they form a complete system.

The AVO-2W-B-P-M-LT5 mainframe is a voltage pulser, designed to operate into two parallel 50 Ohm loads (for a total load impedance of 25 Ohms). The AVX-S1-HC-P1-LT5 output module contains a current-doubling transformer, which requires a load impedance of approximately 6.2 Ohms (e.g., a 5 Ohms resistor in series with a diode with 1.2 Ohms of parasitic resistance). The amplitude at the output of the output module (V_{OUT}) can vary from 0 to 125V, when operating into a 6.2 Ohm load, providing up to 10 Amps of current, approximately.

When driving a diode load in series with a resistor, the diode current is given by:

$$I_{DIODE} = (V_{OUT} / 2 - V_{DIODE}) / (R_{SERIES} + R_{DIODE})$$

where V_{DIODE} is the voltage drop across the diode, R_{DIODE} is the parasitic resistance of the diode, and R_{SERIES} is the resistance of the series resistor. $R_{SERIES} + R_{DIODE}$ should be equal to 6.2 Ohms.

This instrument is intended for use in research and development laboratories.

SPECIFICATIONS

Model ¹ :	AVO-2W-B-P-M-LT5
Amplitude ^{2,3} :	0 to 10 Amperes, into a 6.2 Ω load
Pulse width (FWHM):	1 to 50 ns
Rise & fall time (20%-80%):	≤ 1 ns for PW < 4 ns ≤ 2 ns, for PW ≥ 4 ns
PRF:	0 to 30 kHz
Output impedance:	≈ 6.2 Ohms
Polarity ⁴ :	Positive or negative or both (specify)
GPIO and RS-232 control ¹ :	Standard on -B units.
Telnet / Ethernet control ⁵ :	Optional. See http://www.avtechpulse.com/options/tnt for details.
LabView drivers:	Check http://www.avtechpulse.com/labview for availability and downloads
Propagation delay:	≤ 200 ns (Ext trig in to pulse out)
Jitter (Ext trig in to pulse out):	± 100 ps $\pm 0.03\%$ of sync delay
DC offset or bias insertion:	Optional ⁶ . Apply required DC offset in the range of ± 50 Volts (250 mA max) to solder terminal.
Trigger required:	External trigger mode: +5 Volts, 50 to 500 ns (TTL)
Sync output, delay:	+3 Volts, 100 ns, will drive 50 Ω loads, delay to 200 ns
Gate input:	Synchronous or asynchronous, active high or low, switchable. Suppresses triggering when active.
Monitor output option ⁷ :	Provides a 20 dB attenuated coincident replica of main output
Connectors:	Out: Solder terminals, Trig, Sync, Gate, Monitor: BNC
Power requirements:	100 - 240 Volts, 50 - 60 Hz
Dimensions (H x W x D):	Mainframe: 102x430x375mm (3.9"x17"x14.3"), Output module: 23x28x38mm (0.9"x1.1"x1.5")
Temperature range:	+5°C to +40°C

1) -B suffix indicates IEEE-488.2 GPIO and RS-232 control of amplitude, pulse width, PRF and delay. (See <http://www.avtechpulse.com/gpio>).

2) For electronic control (0 to +10V) of amplitude, suffix model number with -EA. Electronic control units also include the standard front-panel controls.

3) For operation at amplitudes of less than 20% of full-scale, best results will be obtained by setting the amplitude near full-scale and using external attenuators on the output.

4) Indicate desired polarity by suffixing model number with -P or -N (i.e. positive or negative) or -PN for dual polarity option.

5) Add the suffix -TNT to the model number to specify the Telnet / Ethernet control option.

6) For DC offset option suffix model number with -OS.

7) For monitor option add suffix -M.

ORIGINAL QUOTATION

Date: Wed, 16 Nov 2005 10:27:09 -0500
From: Avtech Sales
Subject: Re: one more pulsed laser diode driver

XXXXXX,

I am pleased to re-quote as follows, for a 30 kHz model:

Quote number: 13016.01

Model number: AVO-2W-B-P-M-LT5

Description: Customized Laser Diode Driver (Pulsed Voltage) with IEEE-488.2 GPIB and RS-232 Computer Control Ports

Amplitude: 0 to +10A, into a 6.2 Ohm load

Pulse width (FWHM): 1 to 50 ns

PRF: 1 Hz to 30 kHz

Rise and fall times (20%-80%): < 1 ns for pulse widths below 4 ns, and < 2 ns for pulse width above 4 ns.

Other: as per the standard AVO-2W-B-P, described at <http://www.avtechpulse.com/laser/avo-2w>

Price: \$XXXXXX US each, FOB destination.

Quote valid for: 60 days

Estimated delivery: 60-75 days after receipt of order.

Quote number: 13016.02

Model number: AVX-S1-HC-P1-LT5

Description: Laser Diode Bias Insertion Unit with Socket, designed for use with the AVO-2W-B-P-M-LT5.

-LT5 option: An output module is provided with a socket that will accept pins 8-14 of the user-supplied butterfly-packaged laser diode. A positive pulse will be applied to the diode anode (pin 10). Pins 8-9 and 11-14 will be grounded. Pins 1-7 will remain unconnected and accessible to the user. A series resistance of approximately 5 Ohms will be present in the module. For optimal matching with the AVO-2W-B-P-M-LT5, the laser diode should have a parasitic resistance (dV/dI) of approximately 1.2 Ohms, so that the total resistance is 6.2 Ohms. It is important that you confirm that this is appropriate for your diodes.

Other: similar to the standard AVX-S1-HC-P1, described at
<http://www.avtechpulse.com/laser-bias/avx-s1-hc>

Price: \$XXXXXX US each, FOB destination.

Quote valid for: 60 days

Estimated delivery: 60-75 days after receipt of order.

Please call or email me if I can be of further assistance.

Thank you for your interest in our products!

Regards,
 Dr. Michael J. Chudobiak
 Chief Engineer

--- Avtech Electrosystems Ltd. ----- since 1975 ---

PO Box 265	ph: 1-800-265-6681 or 613-226-5772	Box 5120
Ogdensburg	fax: 1-800-561-1970 or 613-226-2802	LCD Merivale
New York	email: info@avtechpulse.com	Ottawa, Ontario
USA 13669-0265	http://www.avtechpulse.com/	Canada K2C 3H4

Pulse Generators - Laser Diode Drivers - HV Amplifiers
 Monocycle Generators - Impulse Generators - Pulse Amplifiers
 Current Pulsers - Function Generators - Frequency Dividers - and more!

Free catalog & newsletter ~ <http://www.avtechpulse.com/request/>

EUROPEAN REGULATORY NOTES

EC DECLARATION OF CONFORMITY

We Avtech Electrosystems Ltd.
P.O. Box 5120, LCD Merivale
Ottawa, Ontario
Canada K2C 3H4

declare that this pulse generator meets the intent of Directive 89/336/EEC for Electromagnetic Compatibility. Compliance pertains to the following specifications as listed in the official Journal of the European Communities:

EN 50081-1 Emission

EN 50082-1 Immunity

and that this pulse generator meets the intent of the Low Voltage Directive 72/23/EEC as amended by 93/68/EEC. Compliance pertains to the following specifications as listed in the official Journal of the European Communities:

EN 61010-1:2001 Safety requirements for electrical equipment for measurement, control, and laboratory use



DIRECTIVE 2002/95/EC (RoHS)

This instrument is exempt from Directive 2002/95/EC of the European Parliament and of the Council of 27 January 2003 on the Restriction of the use of certain Hazardous Substances (RoHS) in electrical and electronic equipment. Specifically, Avtech instruments are considered "Monitoring and control instruments" (Category 9) as defined in Annex 1A of Directive 2002/96/EC. The Directive 2002/95/EC only applies to Directive 2002/96/EC categories 1-7 and 10, as stated in the "Article 2 - Scope" section of Directive 2002/95/EC.

DIRECTIVE 2002/96/EC (WEEE)

European customers who have purchased this equipment directly from Avtech will have completed a "WEEE Responsibility Agreement" form, accepting responsibility for WEEE

compliance (as mandated in Directive 2002/96/EC of the European Union and local laws) on behalf of the customer, as provided for under Article 9 of Directive 2002/96/EC.

Customers who have purchased Avtech equipment through local representatives should consult with the representative to determine who has responsibility for WEEE compliance. Normally, such responsibilities will lie with the representative, unless other arrangements (under Article 9) have been made.

Requirements for WEEE compliance may include registration of products with local governments, reporting of recycling activities to local governments, and financing of recycling activities.



INSTALLATION

VISUAL CHECK

After unpacking the instrument mainframe and the transformer module, examine to ensure that they have not been damaged in shipment. Visually inspect all connectors, knobs, and handles. Confirm that a power cord and an instrumentation manual (this manual), are with the instrument. If the instrument has been damaged, file a claim immediately with the company that transported the instrument.

POWER RATINGS

This instrument is intended to operate from 100 - 240 V, 50 - 60 Hz.

The maximum power consumption is 57 Watts. Please see the “FUSES” section for information about the appropriate AC and DC fuses.

This instrument is an “Installation Category II” instrument, intended for operation from a normal single-phase supply.

CONNECTION TO THE POWER SUPPLY

An IEC-320 three-pronged recessed male socket is provided on the back panel for AC power connection to the instrument. One end of the detachable power cord that is supplied with the instrument plugs into this socket. The other end of the detachable power cord plugs into the local mains supply. Use only the cable supplied with the instrument. The mains supply must be earthed, and the cord used to connect the instrument to the mains supply must provide an earth connection. (The supplied cord does this.)

 Warning: Failure to use a grounded outlet may result in injury or death due to electric shock. This product uses a power cord with a ground connection. It must be connected to a properly grounded outlet. The instrument chassis is connected to the ground wire in the power cord.

The table below describes the power cord that is normally supplied with this instrument, depending on the destination region:

Destination Region	Description	Manufacturer	Part Number
Continental Europe	European CEE 7/7 "Schuko" 230V, 50Hz	Volex (http://www.volex.com)	17850-C3-326
		Qualtek (http://www.qualtekusa.com)	319004-T01
United Kingdom	BS 1363, 230V, 50Hz	Qualtek (http://www.qualtekusa.com)	370001-E01
Switzerland	SEV 1011, 2 30V, 50Hz	Volex (http://www.volex.com)	2102H-C3-10
Israel	SI 32, 220V, 50Hz	Volex (http://www.volex.com)	2115H-C3-10
North America, and all other areas	NEMA 5-15, 120V, 60 Hz	Qualtek (http://www.qualtekusa.com)	312007-01

PROTECTION FROM ELECTRIC SHOCK

 Operators of this instrument must be protected from electric shock at all times. The owner must ensure that operators are prevented access and/or are insulated from every connection point. In some cases, connections must be exposed to potential human contact. Operators must be trained to protect themselves from the risk of electric shock. This instrument is intended for use by qualified personnel who recognize shock hazards and are familiar with safety precautions required to avoid possibly injury. In particular, operators should:

1. Keep exposed high-voltage wiring to an absolute minimum.
2. Wherever possible, use shielded connectors and cabling.
3. Connect and disconnect loads and cables only when the instrument is turned off.
4. Keep in mind that all cables, connectors, oscilloscope probes, and loads must have an appropriate voltage rating.
5. Do not attempt any repairs on the instrument, beyond the fuse replacement procedures described in this manual. Contact Avtech technical support (see page 2 for contact information) if the instrument requires servicing. Service is to be performed solely by qualified service personnel.

ENVIRONMENTAL CONDITIONS

This instrument is intended for use under the following conditions:

1. indoor use;
2. altitude up to 2 000 m;
3. temperature 5 °C to 40 °C;

4. maximum relative humidity 80 % for temperatures up to 31 °C decreasing linearly to 50 % relative humidity at 40 °C;
5. Mains supply voltage fluctuations up to ± 10 % of the nominal voltage;
6. no pollution or only dry, non-conductive pollution.

LABVIEW DRIVERS

A LabVIEW driver for this instrument is available for download on the Avtech web site, at <http://www.avtechpulse.com/labview>. A copy is also available in National Instruments' Instrument Driver Library at <http://www.natinst.com/>.

FUSES

This instrument contains four fuses. All are accessible from the rear-panel. Two protect the AC prime power input, and two protect the internal DC power supplies. The locations of the fuses on the rear panel are shown in the figure below:



AC FUSE REPLACEMENT

To physically access the AC fuses, the power cord must be detached from the rear panel of the instrument. The fuse drawer may then be extracted using a small flat-head screwdriver, as shown below:



DC FUSE REPLACEMENT

The DC fuses may be replaced by inserting the tip of a flat-head screwdriver into the fuse holder slot, and rotating the slot counter-clockwise. The fuse and its carrier will then pop out.

FUSE RATINGS

The following table lists the required fuses:

Fuses	Nominal Mains Voltage	Rating	Case Size	Recommended Replacement Part	
				Littelfuse Part Number	Digi-Key Stock Number
#1, #2 (AC)	100-240V	0.5A, 250V, Time-Delay	5×20 mm	0218.500HXP	F2416-ND
#3 (DC)	N/A	1.6A, 250V, Time-Delay	5×20 mm	021801.6HXP	F2424-ND
#4 (DC)	N/A	0.5A, 250V, Time-Delay	5×20 mm	0218.500HXP	F2416-ND

The recommended fuse manufacturer is Littelfuse (<http://www.littelfuse.com>).

Replacement fuses may be easily obtained from Digi-Key (<http://www.digikey.com>) and other distributors.

FRONT PANEL CONTROLS

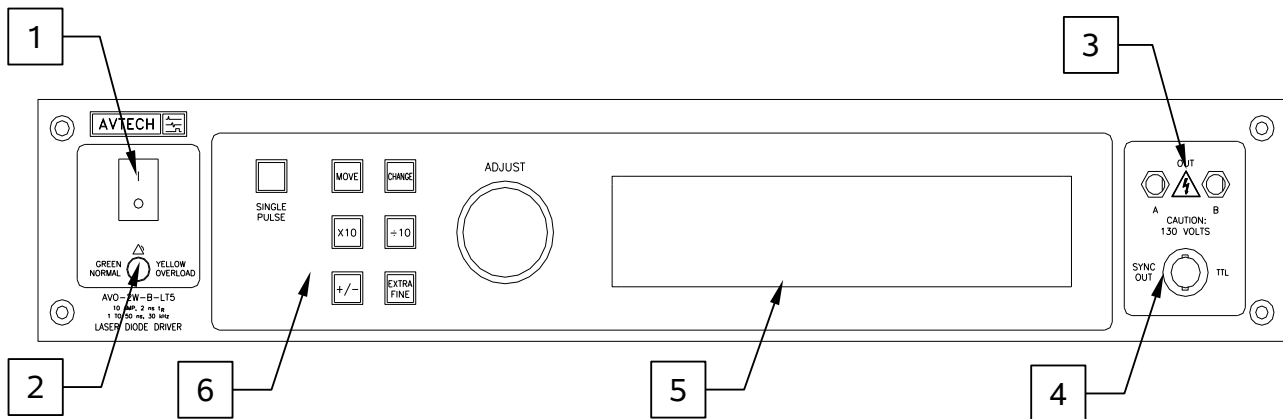

1. POWER Switch. This is the main power switch. When turning the instrument on, there may be a delay of several seconds before the instrument appears to respond.
2. OVERLOAD Indicator. When the instrument is powered, this indicator is normally green, indicating normal operation. If this indicator is yellow, an internal automatic overload protection circuit has been tripped. If the unit is overloaded (by operating at an exceedingly high duty cycle or by operating into a very low impedance), the protective circuit will disable the output of the instrument and turn the indicator light yellow. The light will stay yellow (i.e. output disabled) for about 5 seconds after which the instrument will attempt to re-enable the output (i.e. light green) for about 1 second. If the overload condition persists, the output will be disabled again (i.e. light yellow) for another 5 seconds. If the overload condition has been removed, the instrument will resume normal operation.

This overload indicator may flash yellow briefly at start-up. This is not a cause for concern.

Note that the output stage will safely withstand a short-circuited load condition.

3. OUT CONNECTORS. The two cables from the AVX-S1-HC-P1-LT5 transformer module connect to these SMA connectors. Either cable may connect to either connector - they are identical outputs.

 Caution: Voltages as high as $\pm 130\text{V}$ may be present on the center conductors of these output connectors. Avoid touching this conductor. Connect to this connector using standard coaxial cable, to ensure that the center conductor is not exposed.

4. SYNC OUT. This connector supplies a SYNC output that can be used to trigger other equipment, particularly oscilloscopes. This signal leads (or lags) the main output by a duration set by the "DELAY" controls and has an approximate amplitude of +3 Volts to $R_L > 1\text{ k}\Omega$ with a pulse width of approximately 100 ns.

5. LIQUID CRYSTAL DISPLAY (LCD). This LCD is used in conjunction with the keypad to change the instrument settings. Normally, the main menu is displayed, which lists the key adjustable parameters and their current values. The "Programming Manual for -B Instruments" describes the menus and submenus in detail.
6. KEYPAD.

Control Name	Function
MOVE	This moves the arrow pointer on the display.
CHANGE	This is used to enter the submenu, or to select the operating mode, pointed to by the arrow pointer.
×10	If one of the adjustable numeric parameters is displayed, this increases the setting by a factor of ten.
÷10	If one of the adjustable numeric parameters is displayed, this decreases the setting by a factor of ten.
+/-	If one of the adjustable numeric parameters is displayed, and this parameter can be both positive or negative, this changes the sign of the parameter.
EXTRA FINE	This changes the step size of the ADJUST knob. In the extra-fine mode, the step size is twenty times finer than in the normal mode. This button switches between the two step sizes.
ADJUST	This large knob adjusts the value of any displayed numeric adjustable values, such as frequency, pulse width, etc. The adjust step size is set by the "EXTRA FINE" button. When the main menu is displayed, this knob can be used to move the arrow pointer.

REAR PANEL CONTROLS

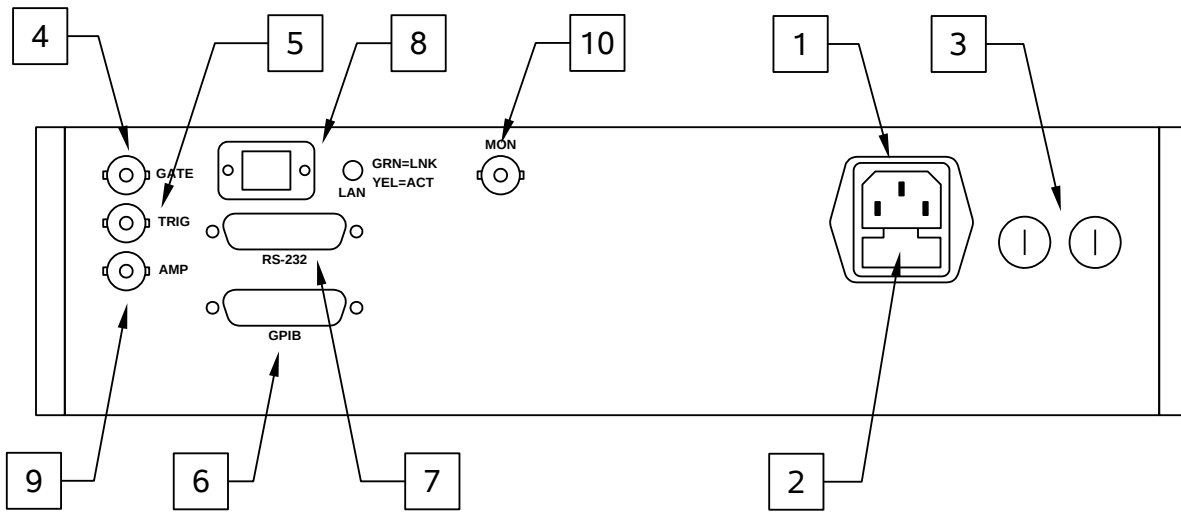

1. AC POWER INPUT. An IEC-320 C14 three-pronged recessed male socket is provided on the back panel for AC power connection to the instrument. One end of the detachable power cord that is supplied with the instrument plugs into this socket.
2. AC FUSE DRAWER. The two fuses that protect the AC input are located in this drawer. Please see the “FUSES” section of this manual for more information.
3. DC FUSES. These two fuses protect the internal DC power supplies. Please see the “FUSES” sections of this manual for more information.
4. GATE. This TTL-level (0 and +5V) logic input can be used to gate the triggering of the instrument. This input can be either active high or active low, depending on the front panel settings or programming commands. (The instrument triggers normally when this input is unconnected). When set to active high mode, this input is pulled-down to ground by a 1 k Ω resistor. When set to active low mode, this input is pulled-up to +5V by a 1 k Ω resistor.
5. TRIG. This TTL-level (0 and +5V) logic input can be used to trigger the instrument, if the instrument is set to triggering externally. The instrument triggers on the rising edge of this input. The input impedance of this input is 1 k Ω . (Depending on the length of cable attached to this input, and the source driving it, it may be desirable to add a coaxial 50 Ohm terminator to this input to provide a proper transmission line termination. The Pasternack (www.pasternack.com) PE6008-50 BNC feed-thru 50 Ohm terminator is suggested for this purpose.)

When triggering externally, the instrument can be set such that the output pulse width tracks the pulse width on this input, or the output pulse width can be set independently.

6. GPIB Connector. A standard GPIB cable can be attached to this connector to allow the instrument to be computer-controlled. See the "Programming Manual for -B Instruments" for more details on GPIB control.
7. RS-232 Connector. A standard serial cable with a 25-pin male connector can be attached to this connector to allow the instrument to be computer-controlled. See the "Programming Manual for -B Instruments" for more details on RS-232 control.
8. LAN Connector and Indicator. (Optional feature. Present on -TNT units only.) The -TNT option "Internet-enables" Avtech pulse generators by adding this standard Ethernet port to the rear panel, in addition to the IEEE-488.2 GPIB and RS-232 ports normally found on "-B" units. Commands are sent using the standard Telnet protocol. The SCPI-compliant command set is the same as that used for GPIB and RS-232 control. The -TNT option uses the Dynamic Host Configuration Protocol (DHCP) to obtain its network address. A DHCP server must be present on the local network for the -TNT option to operate properly.
9. AMP Connector. (Optional feature - present on -EA units only.) The output amplitude can be set to track the voltage on this input. Zero Volts in corresponds to zero amplitude output, and +10V in corresponds to maximum amplitude out. This mode is activated by selecting "Ext Control" on the front-panel amplitude menu, or with the "source:voltage external" command.
10. MON Connector. (Optional feature. Present on "-M" units only.) The monitor output provides an attenuated replica (-20 dB) of the voltage on the main output. The monitor output is designed to operate into a 50 Ohm load.

GENERAL INFORMATION

INSTALLING THE DEVICE UNDER TEST

The AVX-S1-HC-P1-LT5 output module includes two socket arrangements (“P1B” and “T1B” styles) - one for each side of the diode.

The “P1B” socket consists of seven high-bandwidth pin sockets. This socket arrangement will accept pins 8-14 of a standard butterfly package with 0.5 mm wide pins. A positive pulse will be applied to the diode anode (pin 10). Pins 8-9 and 11-13 will be grounded.

The “T1B” socket consists of a low-bandwidth slide-on socket board for pins 1-7 of a butterfly package. A flexible cable connects the slide-on socket to the output module. A male DB-9 connector is provided on the output module, which provides access to the thermal control pins of the diode. DB-9 pin 2 connects to diode pin 2 (TH). DB-9 pin 3 connects to diode pin 5 (TH). DB-9 pin 4 connects to diode pin 1 (TEC+). DB-9 pin 5 connects to diode pin 14 (TEC-). The remaining DB-9 pins are unconnected. Pins 3, 4, 6, and 7 of the diode are grounded. Access to the photodiode, if present, is not provided. This option is designed for compatibility with Thorlabs temperature controllers and Lumics laser diodes. It may be suitable for others as well.

With no diode installed, the output module will look similar to this:

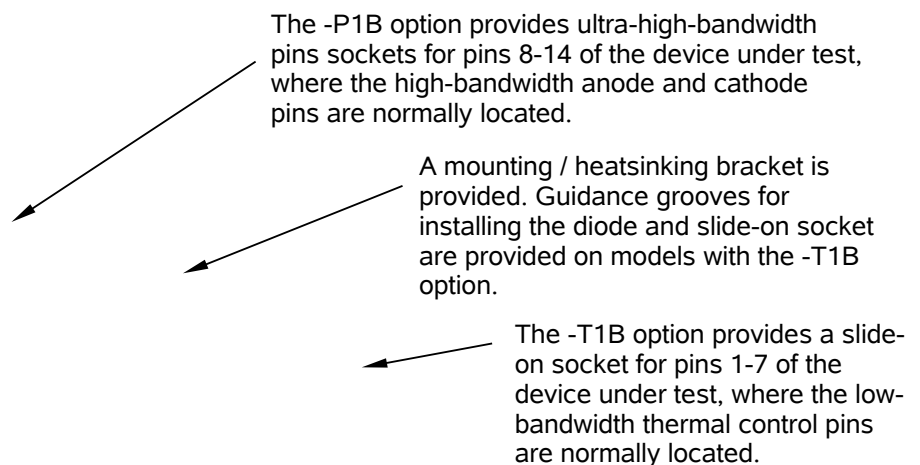

The diode is first installed by sliding pins 8-14 into the “P1B” pin sockets, as shown below:

Gently slide the high-bandwidth side of the device under test into the matching pin sockets. The device can be screwed down to the bracket, if desired.



The T1B slide-on socket assembly can then be slid onto pins 1-7, as shown below:

Gently slide the low-bandwidth slide-on socket onto the matching pins of the device under test. The slide-on socket is connected to the output module using a short length of flexible ribbon cable. The thermoelectric cooler and thermistor pins are made accessible to the user through the "TEC DRIVER" DB-9 connector, which will mate to cables from common third-party TEC controllers.

(The SMA connectors which connect to the cabling from the mainframe are on the module side opposite the pin socket. They are not visible in these photos.)



To optional third-party TEC controller.



BASIC TEST ARRANGEMENT & FUNCTIONAL EQUIVALENT CIRCUIT

The AVO-2W-B-P-M-LT5 should be tested with a sampling oscilloscope with a bandwidth of at least 2 GHz to properly observe the high-speed waveform. A typical test arrangement is shown below:

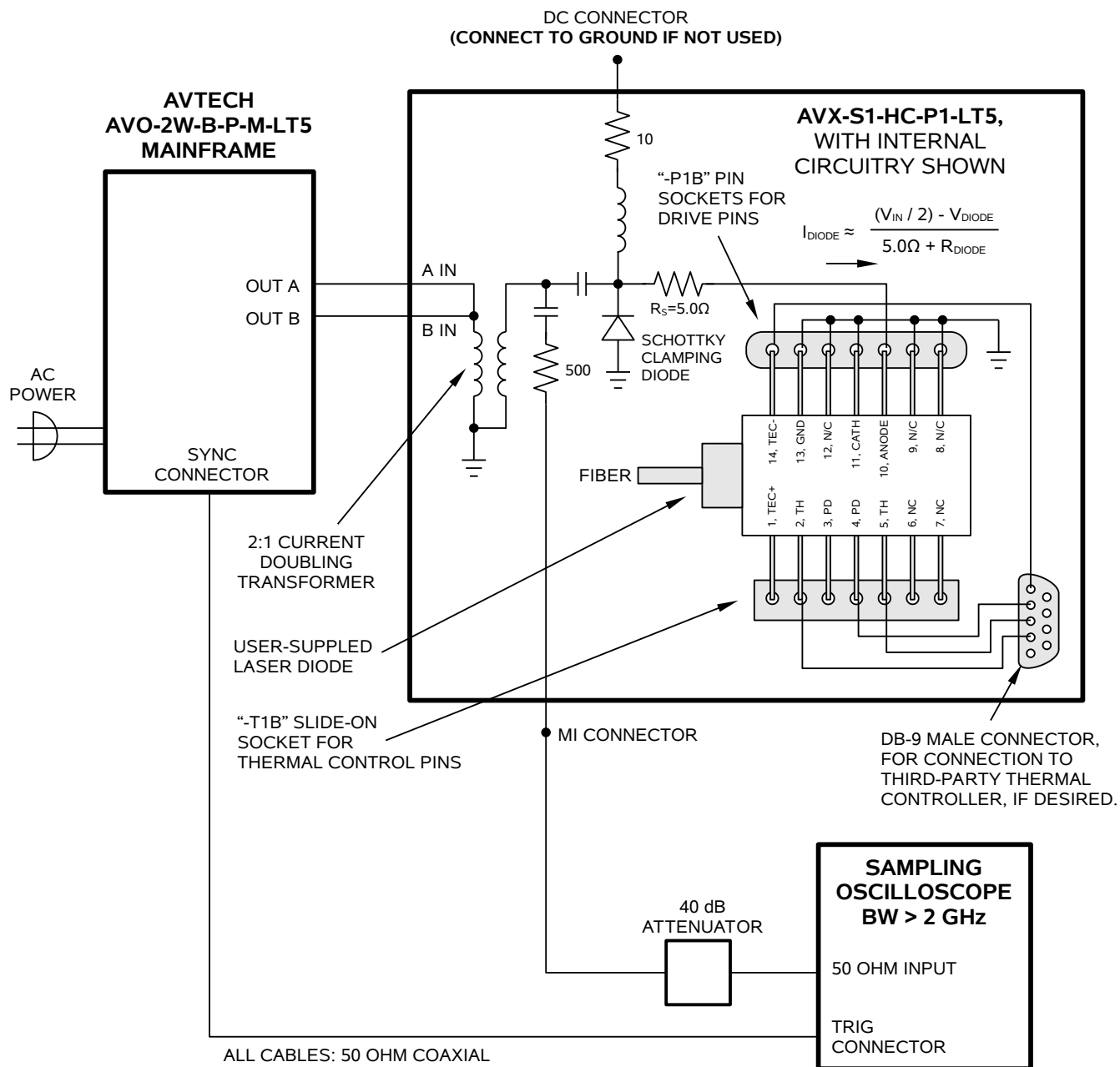

THERMAL CONTROL

Models with the "-T1B" option include a DB-9 male connector that will mate to third-party temperature controllers. These third-party controller provide a means of controlling the thermoelectric cooler that is typically present in butterfly-packaged laser diodes, if desired. The need for cooling is dependent on the user's application. Cooling is generally recommended by device manufacturers.

BASIC PULSE CONTROL

This instrument can be triggered by its own internal clock or by an external TTL trigger signal. In either case, two output channels respond to the trigger: OUT and SYNC. The OUT channel is the signal that is applied to the load. Its amplitude and pulse width are variable. The SYNC pulse is a fixed-width TTL-level reference pulse used to trigger oscilloscopes or other measurement systems. When the delay is set to a positive value the SYNC pulse precedes the OUT pulse. When the delay is set to a negative value the SYNC pulse follows the OUT pulse.

These pulses are illustrated below, assuming internal triggering and a positive delay:

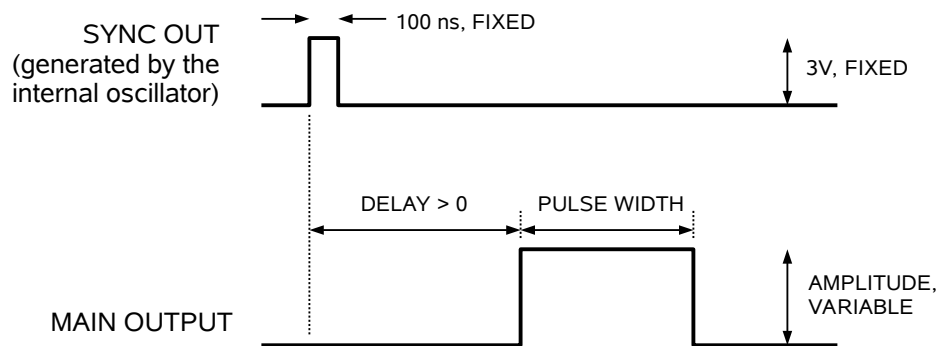

If the delay is negative, the order of the SYNC and OUT pulses is reversed:

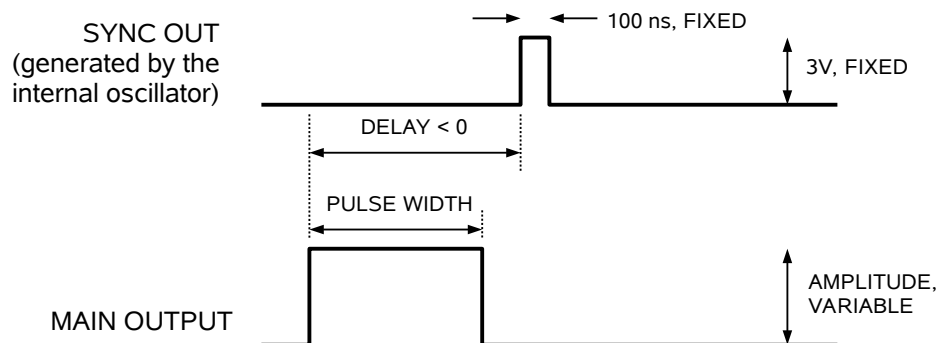

The next figure illustrates the relationship between the signal when an external TTL-level trigger is used:

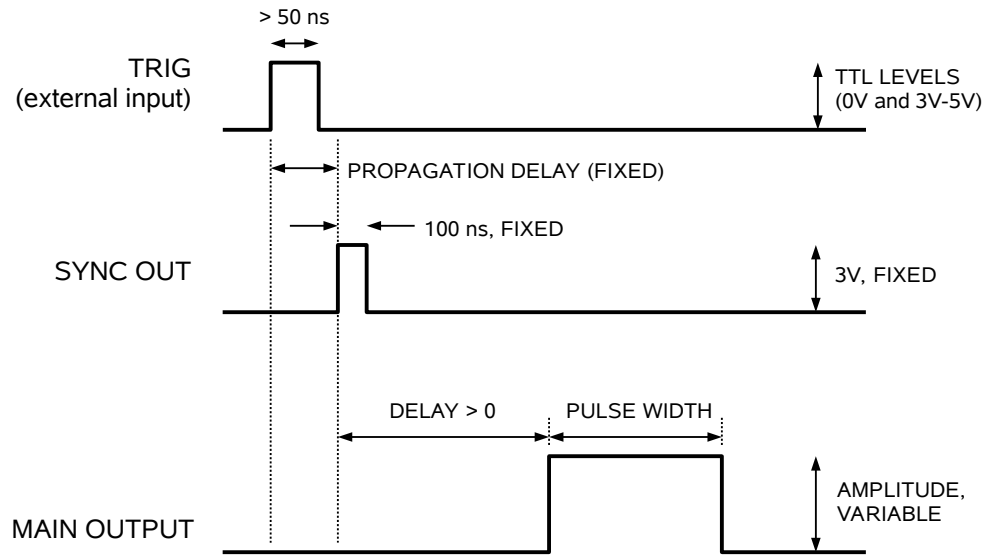

As before, if the delay is negative, the order of the SYNC and OUT pulses is reversed.

The delay, pulse width, and frequency (when in the internal mode), of the OUT pulse can be varied with front panel controls or via the GPIB or RS-232 computer interfaces.

TRIGGER MODES

This instrument has four trigger modes:

- Internal Trigger: the instrument controls the trigger frequency, and generates the clock internally.
- External Trigger: the instrument is triggered by an external TTL-level clock on the back-panel TRIG connector.
- Manual Trigger: the instrument is triggered by the front-panel “SINGLE PULSE” pushbutton.
- Hold Trigger: the instrument is set to not trigger at all.

These modes can be selected using the front panel trigger menu, or by using the appropriate programming commands. (See the “Programming Manual for -B Instruments” for more details.)

GATING MODES

Triggering can be suppressed by a TTL-level signal on the rear-panel GATE connector. The instrument can be set to stop triggering when this input high or low, using the front-panel gate menu or the appropriate programming commands.

PROTECTING YOUR INSTRUMENT

TURN OFF INSTRUMENT WHEN NOT IN USE

The lifetime of the switching elements in the pulse generator module is proportional to the running time of the instrument. For this reason the prime power to the instrument should be turned off when the instrument is not in use. In the case of failure, the switching elements are easily replaced following the procedure described in a following section.

DO NOT EXCEED 30 kHz

The output stage may be damaged if triggered by an external signal at a pulse repetition frequency greater than 30 kHz.

OPERATIONAL CHECK

This section describes a sequence to confirm the basic operation of the instrument. It should be performed after receiving the instrument. It is a useful learning exercise as well. Before proceeding with this procedure, finish read this instruction manual thoroughly. Then read the “Local Control” section of the “Programming Manual for -B Instruments” thoroughly. The “Local Control” section describes the front panel controls used in this operational check - in particular, the MOVE, CHANGE, and ADJUST controls.

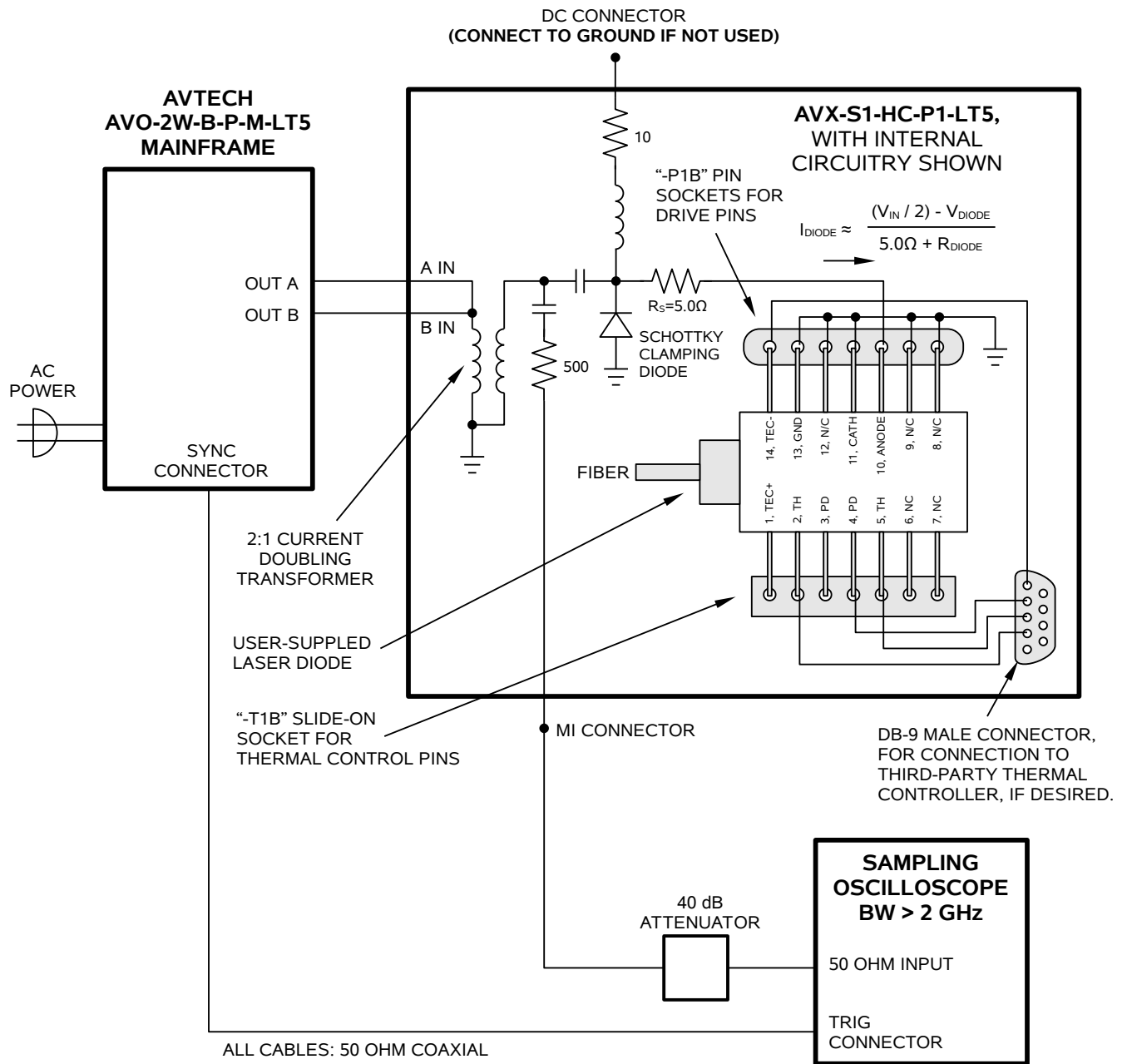

1. Connect the pulse generator to a sampling oscilloscope as shown above. Note that:
 - a) The SYNC output channel provides TTL level signals (approximately 0 and +3V). To avoid overdriving the TRIG input channel of some scopes, a 20 dB attenuator may be required at the input to the scope trigger channel.
 - b) The bandwidth capability of components and instruments used to display the pulse generator output signal (attenuators, cables, connectors, etc.) should exceed 2 GHz.
 - c) Set the oscilloscope to trigger externally with the vertical setting at 50 mV/div and the horizontal setting at 20 ns/div.
2. Turn on the AVO-2W-B-P-M-LT5. The main menu will appear on the LCD.
3. To set the AVO-2W-B-P-M-LT5 to trigger from the internal clock at a PRF of 10 kHz:
 - a) The arrow pointer should be pointing at the frequency menu item. If it is not, press the MOVE button until it is.
 - b) Press the CHANGE button. The frequency submenu will appear. Rotate the ADJUST knob until the frequency is set at 10 kHz.
 - c) The arrow pointer should be pointing at the "Internal" choice. If it is not, press MOVE until it is.
 - d) Press CHANGE to return to the main menu.
4. To set the delay to 100 ns:
 - a) Press the MOVE button until the arrow pointer is pointing at the delay menu item.
 - b) Press the CHANGE button. The delay submenu will appear. Rotate the ADJUST knob until the delay is set at 100 ns.
 - c) The arrow pointer should be pointing at the "Normal" choice. If it is not, press MOVE until it is.
 - d) Press CHANGE to return to the main menu.
5. To set the pulse width to 20 ns:
 - a) Press the MOVE button until the arrow pointer is pointing at the pulse width menu item.

- b) Press the CHANGE button. The pulse width submenu will appear. Rotate the ADJUST knob until the pulse width is set at 20 ns.
 - c) The arrow pointer should be pointing at the “Normal” choice. If it is not, press MOVE until it is.
 - d) Press CHANGE to return to the main menu.
6. At this point, nothing should appear on the oscilloscope.
7. To enable the output:
- a) Press the MOVE button until the arrow pointer is pointing at the output menu item.
 - b) Press the CHANGE button. The output submenu will appear.
 - c) Press MOVE until the arrow pointer is pointing at the “ON” choice.
 - d) Press CHANGE to return to the main menu.
8. To change the output amplitude:
- a) Press the MOVE button until the arrow pointer is pointing at the amplitude menu item.
 - b) Press the CHANGE button. The amplitude submenu will appear. Rotate the ADJUST knob until the amplitude is set at 125V.
 - c) Observe the oscilloscope. You should see 20 ns wide, 56 mV pulses ($10 \text{ A} \times 6.2\Omega / 11 \times -40\text{dB} = 56 \text{ mV}$), approximately. If you do not, you may need to adjust the delay setting to a value more compatible with your sampling oscilloscope. Repeat step 4 if required. You may also need to adjust the sampling scope controls.
 - d) Rotate the ADJUST knob. The amplitude as seen on the oscilloscope should vary. Return it to 125V.
 - e) Press CHANGE to return to the main menu.
9. Try varying the pulse width, by repeating step (5). As you rotate the ADJUST knob, the pulse width on the oscilloscope will change. It should agree with the displayed value.

This completes the operational check.

PROGRAMMING YOUR PULSE GENERATOR

KEY PROGRAMMING COMMANDS

The “Programming Manual for -B Instruments” describes in detail how to connect the pulse generator to your computer, and the programming commands themselves. A large number of commands are available; however, normally you will only need a few of these. Here is a basic sample sequence of commands that might be sent to the instrument after power-up:

*rst	(resets the instrument)
trigger:source internal	(selects internal triggering)
frequency 1000 Hz	(sets the frequency to 1000 Hz)
pulse:width 10 ns	(sets the pulse width to 10 ns)
pulse:delay 200 ns	(sets the delay to 200 ns)
volt 80	(sets the amplitude to 80 V)
output on	(turns on the output)

For triggering a single event, this sequence would be more appropriate:

*rst	(resets the instrument)
trigger:source hold	(turns off all triggering)
pulse:width 10 ns	(sets the pulse width to 10 ns)
output on	(turns on the output)
volt 80	(sets the amplitude to 80 V)
trigger:source immediate	(generates a single non-repetitive trigger event)
trigger:source hold	(turns off all triggering)
output off	(turns off the output)

To set the instrument to trigger from an external TTL input:

*rst	(resets the instrument)
trigger:source external	(selects external triggering)
pulse:width 10 ns	(sets the pulse width to 10 ns)
pulse:delay 200 ns	(sets the delay to 200 ns)
volt 80	(sets the amplitude to 80 V)
output on	(turns on the output)

These commands will satisfy 90% of your programming needs.

ALL PROGRAMMING COMMANDS

For more advanced programmers, a complete list of the available commands is given below. These commands are described in detail in the “Programming Manual for -B Instruments”. (Note: this manual also includes some commands that are not implemented in this instrument. They can be ignored.)

<u>Keyword</u>	<u>Parameter</u>	<u>Notes</u>
LOCAL		
OUTPut:		
:[STATe]	<boolean value>	
:PROTection		
:TRIPped?		[query only]
REMOTE		
[SOURce]:		
:FREQuency		
[:CW FIXed]	<numeric value>	
[SOURce]:		
:PULSe		
:PERiod	<numeric value>	
:WIDTh	<numeric value>	
:DCYClE	<numeric value>	
:HOLD	WIDTh DCYClE	
:DELay	<numeric value>	
:GATE		
:LEVeL	High Low	
[SOURce]:		
:VOLTage		
[:LEVeL]		
[:IMMeDiate]		
[:AMPLitude]	<numeric value> EXTeRnal	
:PROTection		
:TRIPped?		[query only]
STATUS:		
:OPERation		
:[EVENT]?		[query only, always returns "0"]
:CONDition?		[query only, always returns "0"]
:ENABle	<numeric value>	[implemented but not useful]
:QUEStionable		
:[EVENT]?		[query only, always returns "0"]
:CONDition?		[query only, always returns "0"]
:ENABle	<numeric value>	[implemented but not useful]
SYSTEM:		
:COMMunicate		
:GPIB		
:ADDReSS	<numeric value>	
:SERial		
:CONTRol		
:RTS	ON IBFull RFR	
:[RECeive]		
:BAUD	1200 2400 4800 9600	
:BITS	7 8	
:ECHO	<boolean value>	
:PARity		
:[TYPE]	EVEN ODD NONE	

	:SBITS	1 2	
:ERRor			
:[NEXT]?			[query only]
:COUNT?			[query only]
:VERSion?			[query only]
TRIGger:			
:SOURce		INTernal EXTernal MANual HOLD IMMEDIATE	
*CLS			[no query form]
*ESE		<numeric value>	
*ESR?			[query only]
*IDN?			[query only]
*OPC			
*SAV		0 1 2 3	[no query form]
*RCL		0 1 2 3	[no query form]
*RST			[no query form]
*SRE		<numeric value>	
*STB?			[query only]
*TST?			[query only]
*WAI			[no query form]

MECHANICAL INFORMATION

TOP COVER REMOVAL

If necessary, the interior of the instrument may be accessed by removing the four Phillips screws on the top panel. With the four screws removed, the top cover may be slid back (and off).

 Always disconnect the power cord and allow the instrument to sit unpowered for 10 minutes before opening the instrument. This will allow any internal stored charge to discharge.

There are no user-adjustable internal circuits. For repairs other than fuse replacement, please contact Avtech (info@avtechpulse.com) to arrange for the instrument to be returned to the factory for repair. Service is to be performed solely by qualified service personnel.

 Caution: High voltages are present inside the instrument during normal operation. Do not operate the instrument with the cover removed.

RACK MOUNTING

A rack mounting kit is available. The -R5 rack mount kit may be installed after first removing the one Phillips screw on the side panel adjacent to the front handle.

ELECTROMAGNETIC INTERFERENCE

To prevent electromagnetic interference with other equipment, all used outputs should be connected to shielded loads using shielded coaxial cables. Unused outputs should be terminated with shielded coaxial terminators or with shielded coaxial dust caps, to prevent unintentional electromagnetic radiation. All cords and cables should be less than 3m in length.

MAINTENANCE

REGULAR MAINTENANCE

This instrument does not require any regular maintenance.

On occasion, one or more of the four rear-panel fuses may require replacement. All fuses can be accessed from the rear panel. See the “FUSES” section for details.

CLEANING

If desired, the interior of the instrument may be cleaned using compressed air to dislodge any accumulated dust. (See the “TOP COVER REMOVAL” section for instructions on accessing the interior.) No other cleaning is recommended.

WIRING DIAGRAMS

WIRING OF AC POWER

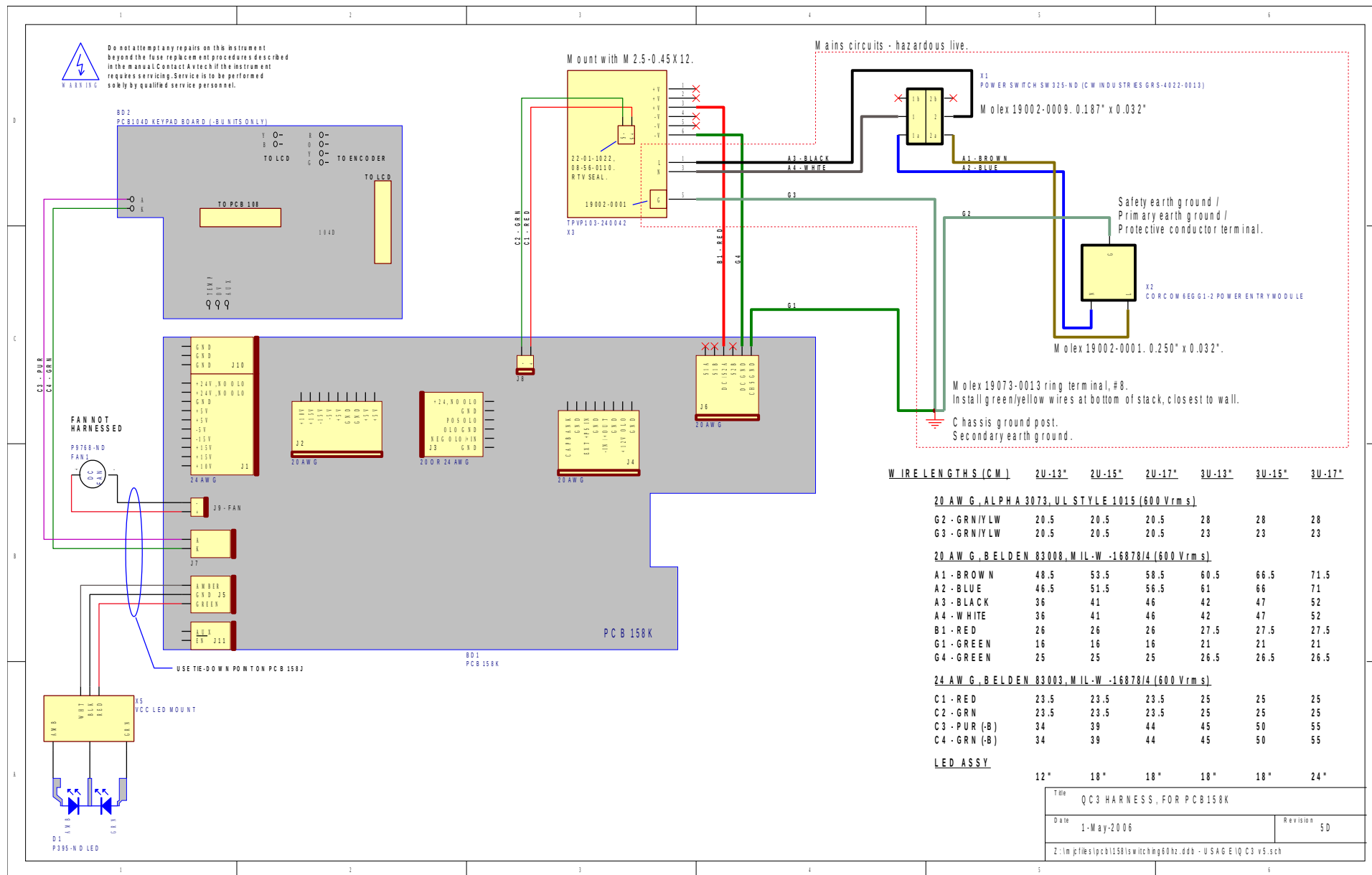

PCB 158K - LOW VOLTAGE POWER SUPPLY, 1/3

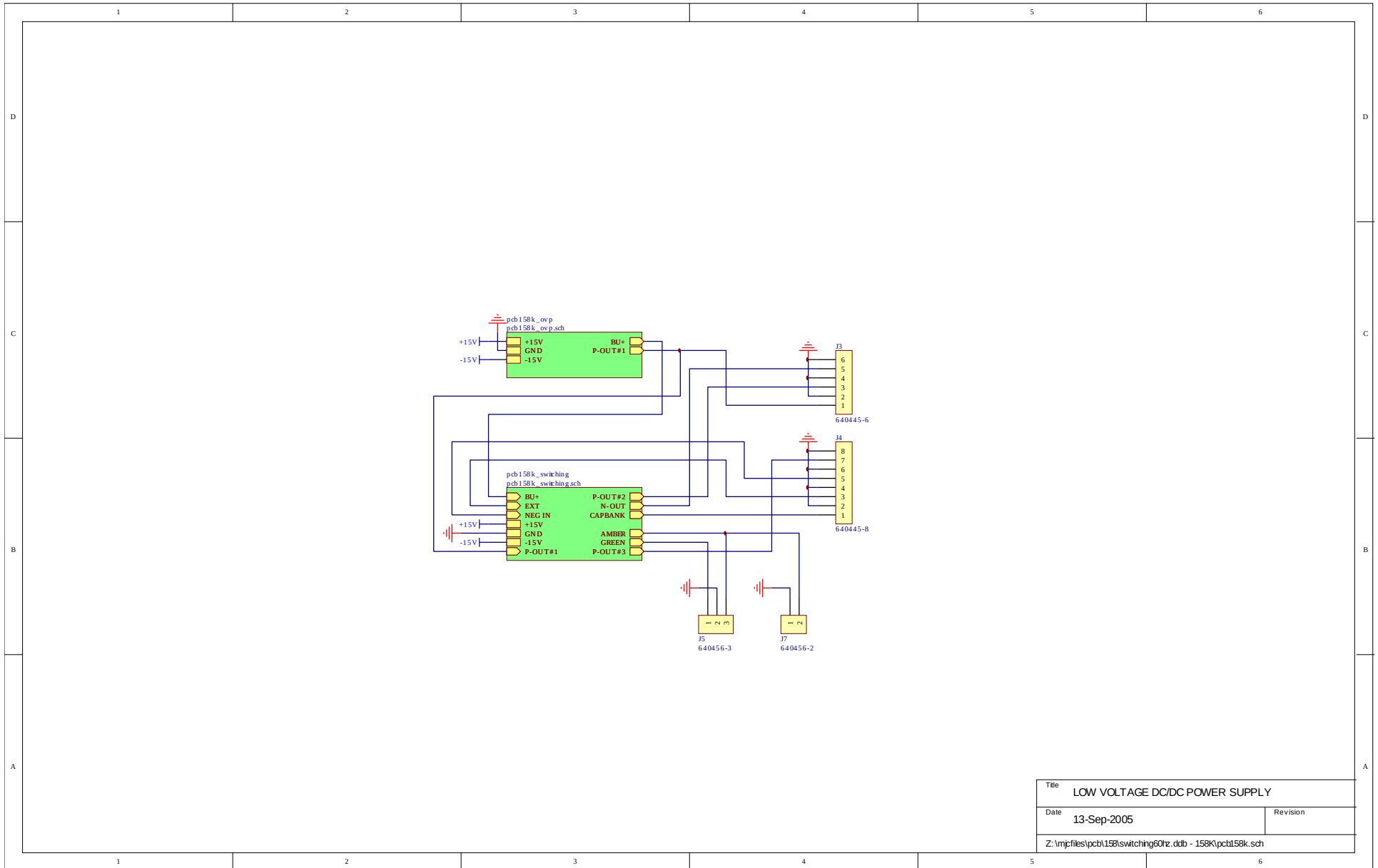

Title		LOW VOLTAGE DC/DC POWER SUPPLY
Date	13-Sep-2005	Revision
Z:\mpjfiles\pcb158\switching01rz.ddb - 158K\pcb158k.sch		

PCB 158K - LOW VOLTAGE POWER SUPPLY, 2/3

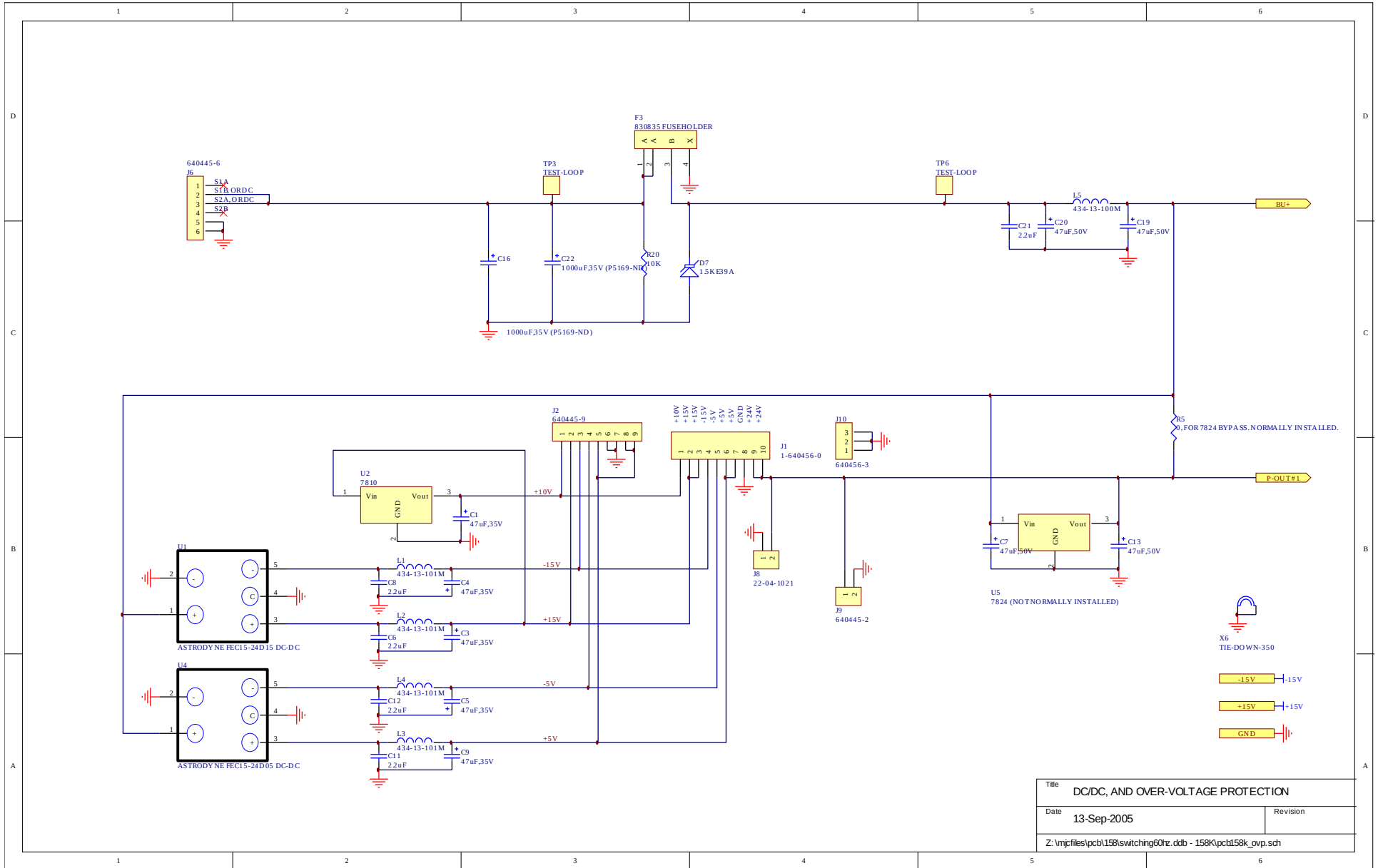

PCB 158K - LOW VOLTAGE POWER SUPPLY, 3/3

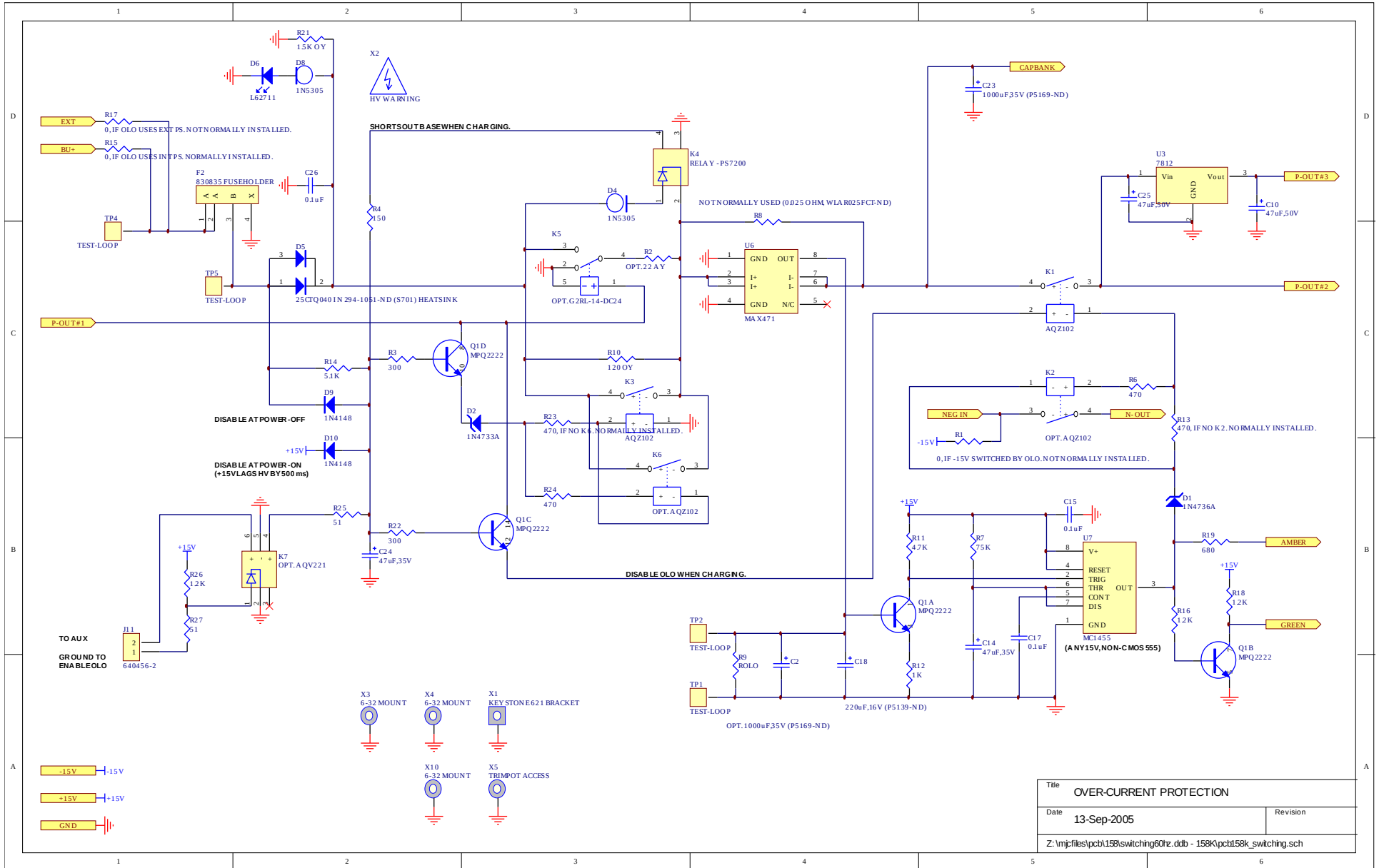

PCB 168B - HIGH VOLTAGE DC POWER SUPPLY

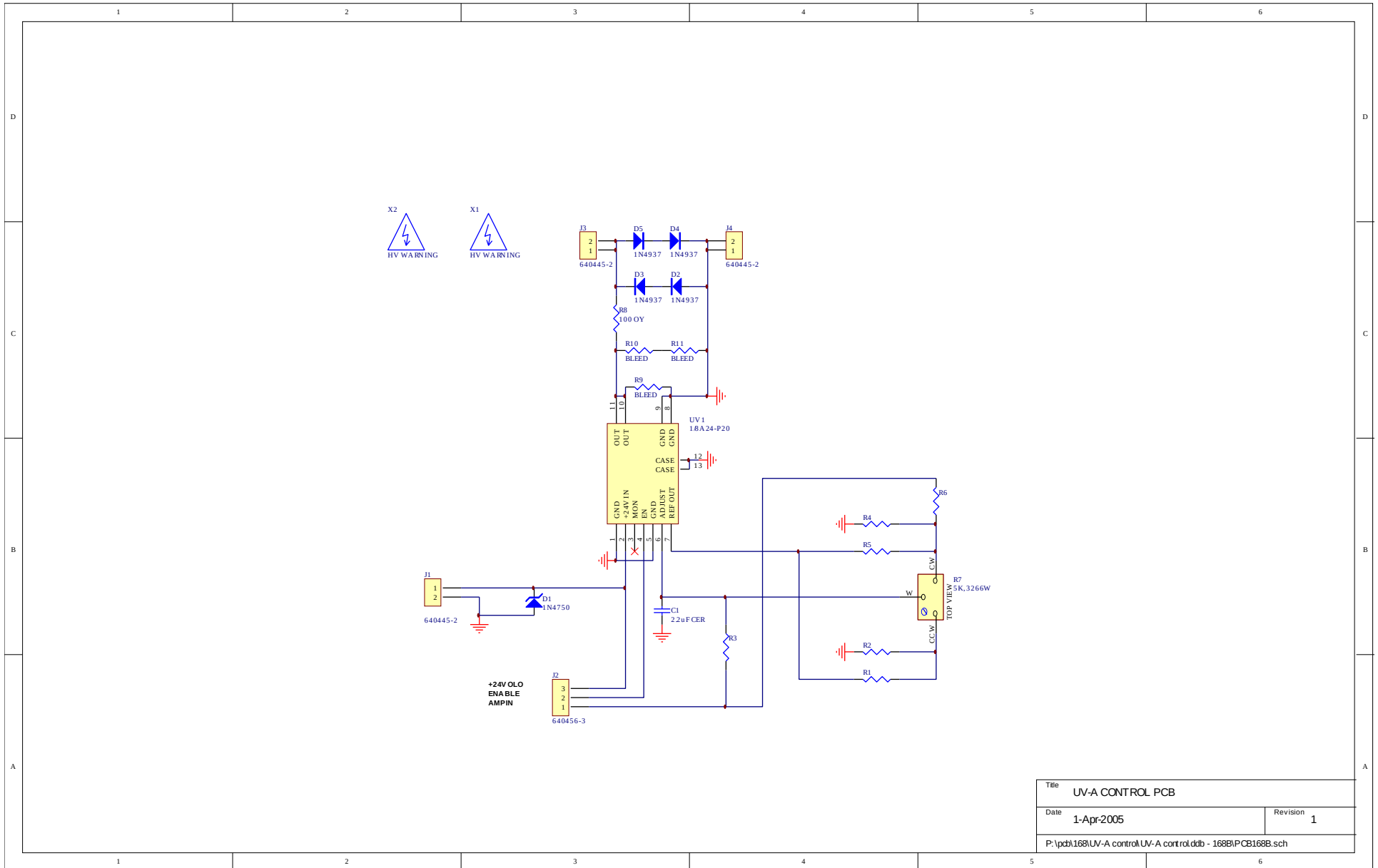

Title UV-A CONTROL PCB	
Date 1-Apr-2005	Revision 1
P:\pcb\168\UV-A control\UV-A control.dtb - 168B\PCB168B.sch	

PCB 104D - KEYPAD / DISPLAY BOARD, 1/3

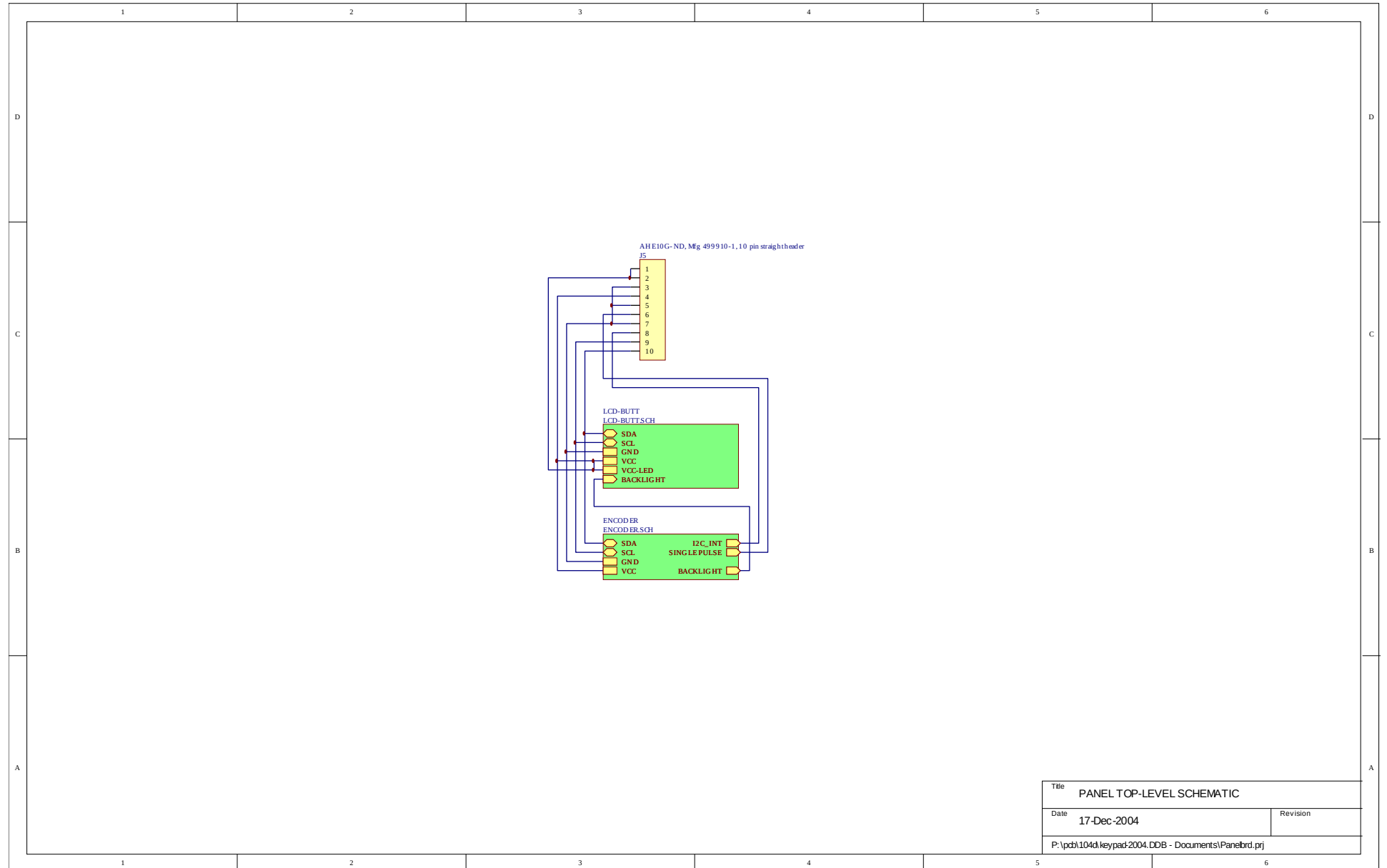

Title	PANEL TOP-LEVEL SCHEMATIC	
Date	17-Dec-2004	Revision
P:\pcb\104d\keypad\2004.DDB - Documents\Panelbrd.prj		

PCB 104D - KEYPAD / DISPLAY BOARD, 2/3

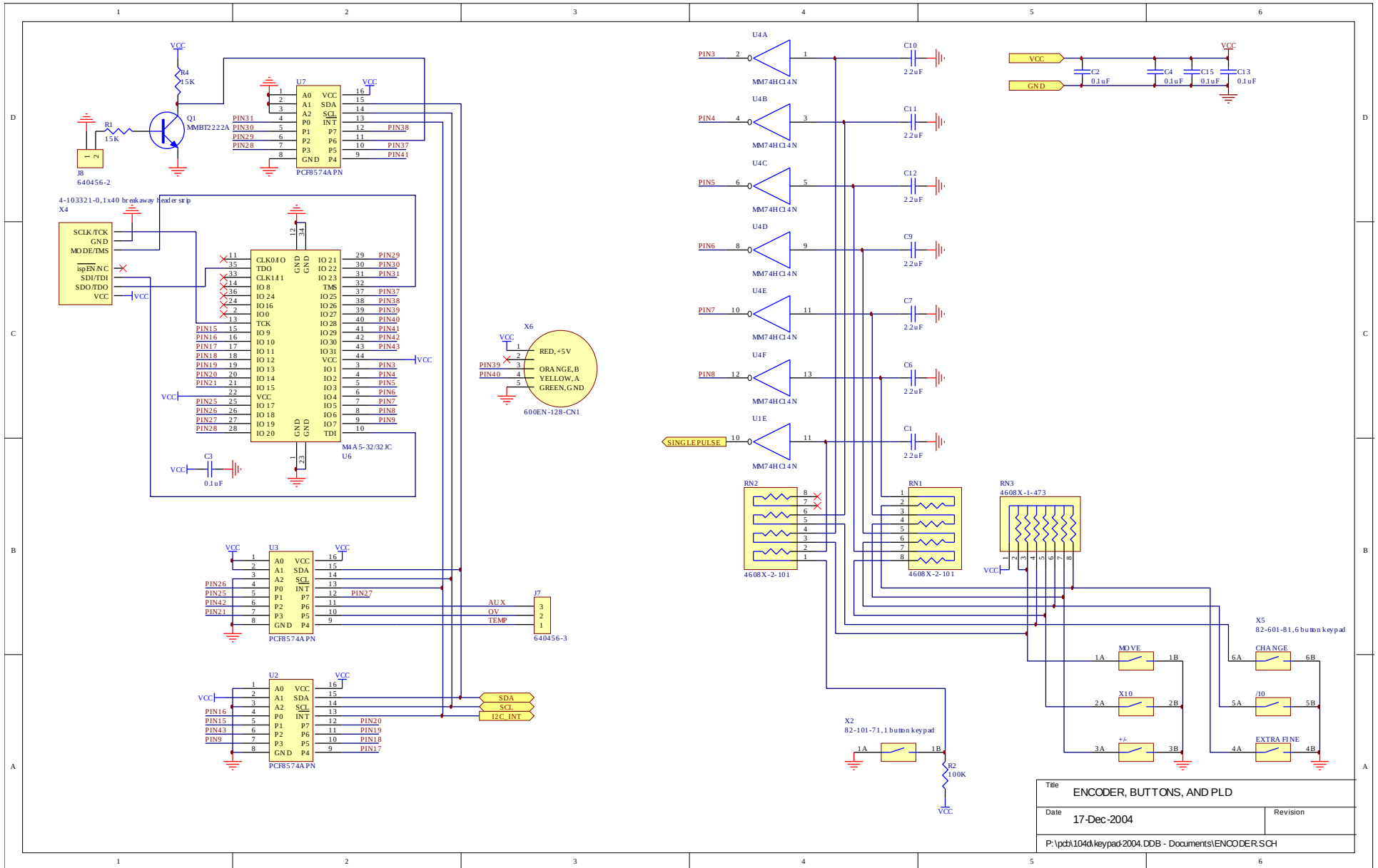

Title		ENCODER, BUTTONS, AND PLD
Date	17-Dec-2004	Revision
P:\pcb\104d\keypad\2004.DDB - Documents\ENCODER.SCH		

PCB 104D - KEYPAD / DISPLAY BOARD, 3/3

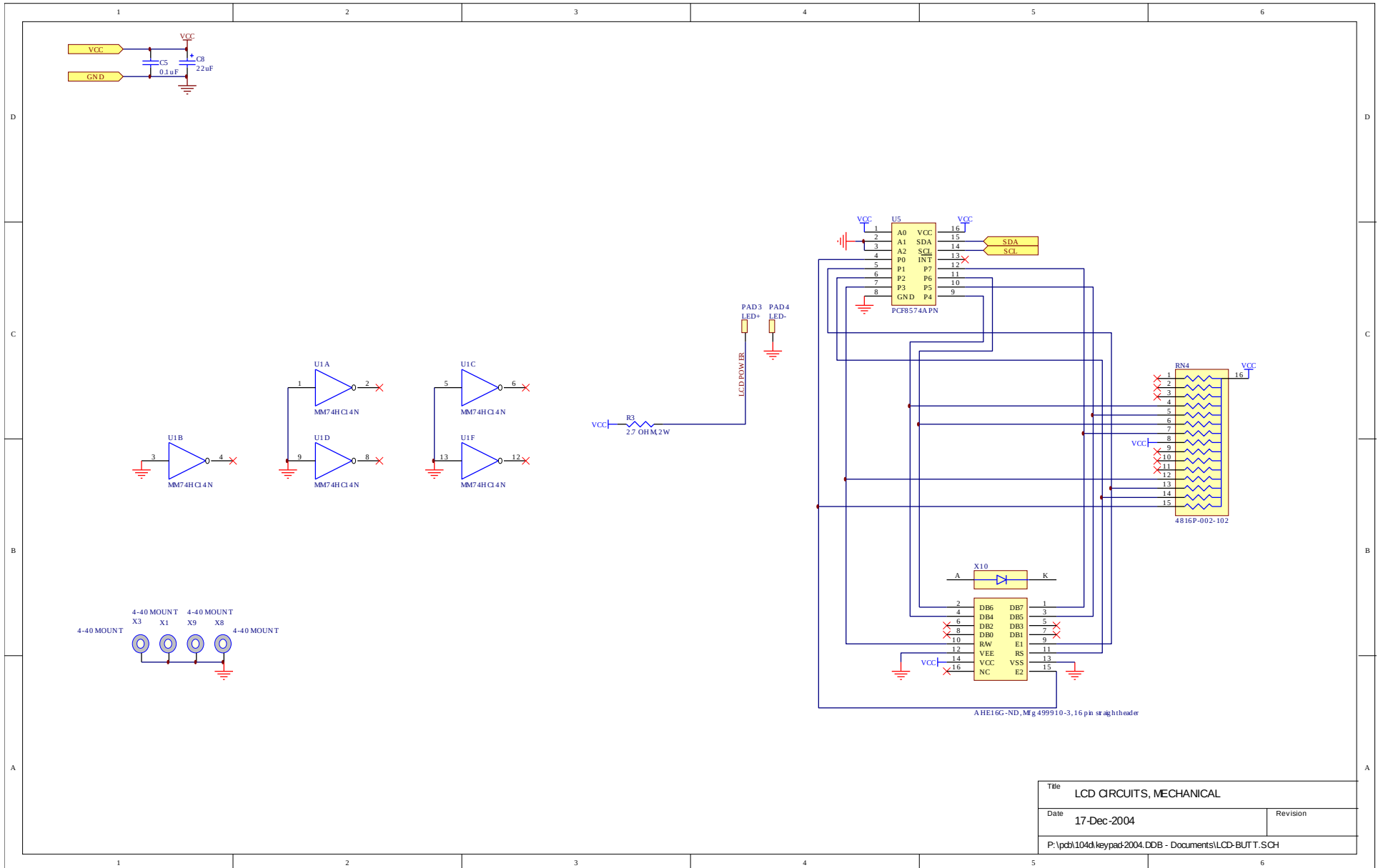

PCB 101B - DRIVE SIGNAL BOARD

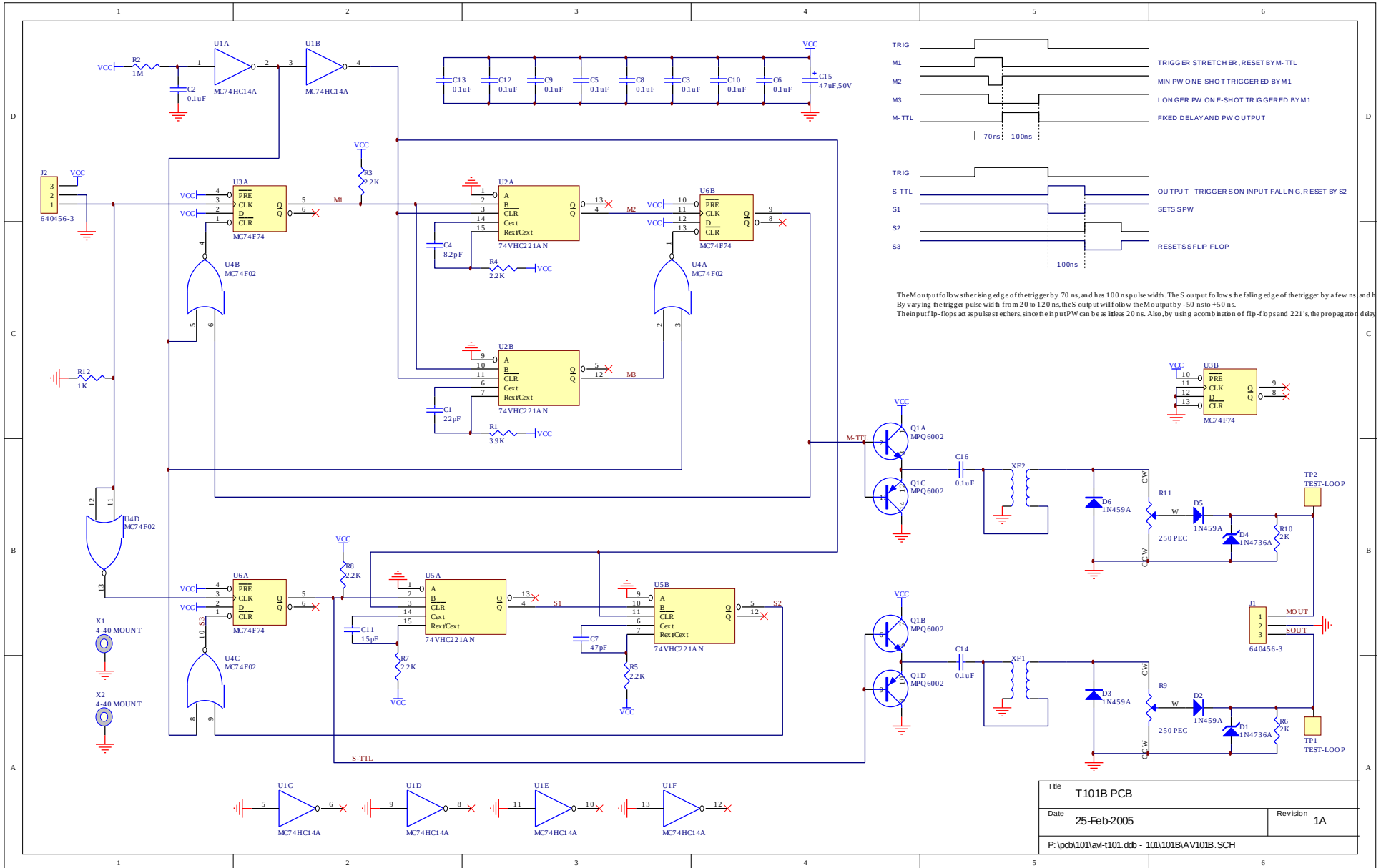

PERFORMANCE CHECKSHEET