



AVTECH ELECTROSYSTEMS LTD.

NANOSECOND WAVEFORM ELECTRONICS
SINCE 1975

P.O. BOX 265
OGDENSBURG, NY
U.S.A. 13669-0265
TEL: (315) 472-5270
FAX: (613) 226-2802

TEL: 1-800-265-6681
FAX: 1-800-561-1970

e-mail: info@avtechpulse.com
<http://www.avtechpulse.com/>

BOX 5120, LCD MERIVALE
OTTAWA, ONTARIO
CANADA K2C 3H4
TEL: (613) 226-5772
FAX: (613) 226-2802

INSTRUCTIONS

MODEL AVO-5-B

0 TO 28 Amp (0 to 84 Volts)
5 kHz LASER DIODE DRIVER
WITH IEEE 488.2 AND RS-232 CONTROL

SERIAL NUMBER: _____

WARRANTY

Avtech Electrosystems Ltd. warrants products of its manufacture to be free from defects in material and workmanship under conditions of normal use. If, within one year after delivery to the original owner, and after prepaid return by the original owner, this Avtech product is found to be defective, Avtech shall at its option repair or replace said defective item. This warranty does not apply to units which have been disassembled, modified or subjected to conditions exceeding the applicable specifications or ratings. This warranty is the extent of the obligation assumed by Avtech with respect to this product and no other warranty or guarantee is either expressed or implied.

TECHNICAL SUPPORT

Phone: 613-226-5772 or 1-800-265-6681

Fax: 613-226-2802 or 1-800-561-1970

E-mail: info@avtechpulse.com

World Wide Web: <http://www.avtechpulse.com>

TABLE OF CONTENTS

WARRANTY.....	2
TECHNICAL SUPPORT.....	2
TABLE OF CONTENTS.....	3
INTRODUCTION.....	4
SPECIFICATIONS.....	5
INSTALLATION.....	6
VISUAL CHECK.....	6
PLUGGING IN THE INSTRUMENT.....	6
CONNECTING THE OUTPUT MODULE TO THE MAINFRAME.....	7
LABVIEW DRIVERS.....	7
FRONT PANEL CONTROLS.....	8
REAR PANEL CONTROLS.....	10
GENERAL INFORMATION.....	12
AMPLITUDE CONTROL.....	12
BASIC PULSE CONTROL.....	12
TRIGGER MODES.....	14
GATING MODES.....	15
TOP COVER REMOVAL.....	15
RACK MOUNTING.....	15
OPERATIONAL CHECK.....	16
PROGRAMMING YOUR PULSE GENERATOR.....	19
KEY PROGRAMMING COMMANDS.....	19
ALL PROGRAMMING COMMANDS.....	20
PERFORMANCE CHECK SHEET.....	22

INTRODUCTION

The AVO-5-B is a high performance, GPIB and RS232-equipped instrument capable of generating 0 to 28 A at repetition rates up to 5 kHz. The pulse width is variable from 20 ns to 200 ns. Rise and fall times are fixed at less than 5 ns. The AVO-5-B includes an internal trigger source, but it can also be triggered or gated by an external source. A front-panel pushbutton can also be used to trigger the instrument.

The AVO-5-B features front panel keyboard and adjust knob control of the output pulse parameters along with a four line by 40 character back-lit LCD display of the output amplitude, pulse width, pulse repetition frequency, and delay. The instrument includes memory to store up to four complete instrument setups. The operator may use the front panel or the computer interface to store a complete “snapshot” of all key instrument settings, and recall this setup at a later time.

The instrument is protected against overload conditions by an automatic control circuit. An internal power supply monitor removes the power to the output stage for five seconds if an average power overload exists. After that time, the unit operates normally for one second, and if the overload condition persists, the power is cut again. This cycle repeats until the overload is removed.

The AVO-5-B consists of two parts, the mainframe and the output module. The mainframe is a voltage pulser. The output module contains a series of transformers, and amplitude at the output of the output module (V_{OUT}) can vary from 0 to 84V, when operating into the required 3.0 Ohm load. A diode load may be connected in series with this resistance, so that the current through the diode is normally given by:

$$I_{DIODE} \approx (V_{OUT} - V_{DIODE}) \div (R_{SERIES} + R_{DIODE})$$

where V_{OUT} is the mainframe output voltage, V_{DIODE} is the forward voltage drop across the diode (typically 2-3V for a laser diode), R_{DIODE} is the parasitic resistance of the diode, and R_{SERIES} is a resistor added in series with the diode such that $R_{SERIES} + R_{DIODE} = 3 \Omega$.

SPECIFICATIONS

Model:	AVO-5-B
GPIO and RS-232 control ² :	Standard on -B units.
Amplitude ^{3,4} :	0 to 28 A ⁶
Required load impedance:	3 Ω ^{5,6}
Pulse width (FWHM):	6 to 100 ns
Maximum duty cycle:	N/A
Rise time (20%-80%):	3 ns (standard) or 3 to 10 ns variable (option ⁷)
Fall time (80%-20%):	4 ns (standard) or 4 to 10 ns variable (option ⁷)
PRF:	0 to 5 kHz
Output impedance:	\approx 3 Ohm
Polarity ⁸ :	Positive or negative or both (specify)
Propagation delay:	\leq 350 ns (Ext trig in to pulse out)
Jitter:	\pm 100 ps \pm 0.03% of sync delay (Ext trig in to pulse out)
Trigger required:	External trig mode: +5 Volts, 50 to 500 ns (TTL)
Variable Sync delay:	0 to 200 ns (Sync out to pulse out)
Sync output:	+ 3 Volt, 200 ns, will drive 50 Ohm loads
Gate input:	Synchronous or asynchronous, active high or low, switchable. Suppresses triggering when active.
Monitor output option ⁹ :	Provides a 20 dB attenuated coincident replica of main output.
Connectors:	OUT: Solder terminals, or optional plug-in socket similar to AVX-S3 series ¹⁰ TRIG, SYNC, GATE (-B only): BNC MONITOR (optional ⁹): BNC
Power requirements:	100 - 240 Volts, 50 - 60 Hz
Dimensions: Mainframe:	100 \times 430 \times 375 mm (3.9" \times 17" \times 14.8")
Transformer Module:	23 \times 28 \times 38 mm (0.9" \times 1.1" \times 1.5")
Chassis material:	Cast aluminum frame and handles, blue vinyl on aluminum cover plates
Mounting:	Any
Temperature range:	+ 5°C to + 40°C

- 1) -C suffix indicates stand-alone lab instrument with internal clock and line powering. (See <http://www.avtechpulse.com/formats/> for additional details of the basic instrument formats).
- 2) -B suffix indicates IEEE-488.2 GPIO and RS-232 control of amplitude, pulse width, PRF and delay. (See <http://www.avtechpulse.com/gpib>).
- 3) For analog electronic control (0 to + 10 V) of amplitude, suffix model number with -EA. Electronic control units also include standard front-panel controls.
- 4) The minimum useful amplitude is approximately 20% of the maximum amplitude. The waveform may be distorted below this level.
- 5) The AVO-5 mainframe is essentially identical to Model AVL-2 and therefore may be used as a 320 Volt, 50 Ohm pulse generator (SMA output connectors). See <http://www.avtechpulse.com/speed/avl-2>.
- 6) The load impedance for the AVO-5 may be reduced to as low as zero Ohms. The maximum output amplitude increases for lower load impedances, to a maximum of 50 A at zero Ohms. However, the rise time, fall time, and waveform distortion (ringing) may increase at impedances lower than 3 Ohms, due to the impedance mismatch.
- 7) For variable rise, fall time option, add suffix -T1 to model number. Control is by a 10-position switch. Not available on -B units.
- 8) Indicate desired polarity by suffixing model number with -P or -N (i.e. positive or negative) or -PN for dual polarity option.
- 9) For monitor option add suffix -M.
- 10) To specify diode socket mounting option, suffix model number with -S3. When ordering, customer must also specify the diode package type (e.g. TO-18) and the required pin connections (e.g. anode, cathode, ground, etc.). See AVX-S Series for readily available package mounting. Contact Avtech for special or different packages.

INSTALLATION

VISUAL CHECK

After unpacking the mainframe and the output module, examine them to ensure that they have not been damaged in shipment. Visually inspect all connectors, knobs, liquid crystal displays (LCDs), and the handles. Confirm that a power cord, a GPIB cable, and two instrumentation manuals (this manual and the “Programming Manual for -B Instruments”) are with the instrument. If the instrument has been damaged, file a claim immediately with the company that transported the instrument.

PLUGGING IN THE INSTRUMENT

Examine the rear of the instrument. There will be a male power receptacle, a fuse holder and the edge of the power selector card visible. Confirm that the power selector card is in the correct orientation.

For AC line voltages of 110-120V, the power selector card should be installed so that the “120” marking is visible from the rear of the instrument, as shown below:



For AC line voltages of 220-240V, the power selector card should be installed so that the “240” marking is visible from the rear of the instrument, as shown below:



If it is not set for the proper voltage, remove the fuse and then grasp the card with a pair of pliers and remove it. Rotate horizontally through 180 degrees. Reinstall the card and the correct fuse.

In the 120V setting, a 1.0A slow blow fuse is required. In the 240V setting, a 0.5A slow blow fuse is required.

CONNECTING THE OUTPUT MODULE TO THE MAINFRAME

The AVO-5-T output module must be connected to the “OUT” SMA connectors on the rear panel of the mainframe (see the “General Information” section for details).

LABVIEW DRIVERS

A LabVIEW driver for this instrument is available for download on the Avtech web site, at <http://www.avtechpulse.com/labview>. A copy is also available in National Instruments' Instrument Driver Library at <http://www.natinst.com/>.

FRONT PANEL CONTROLS

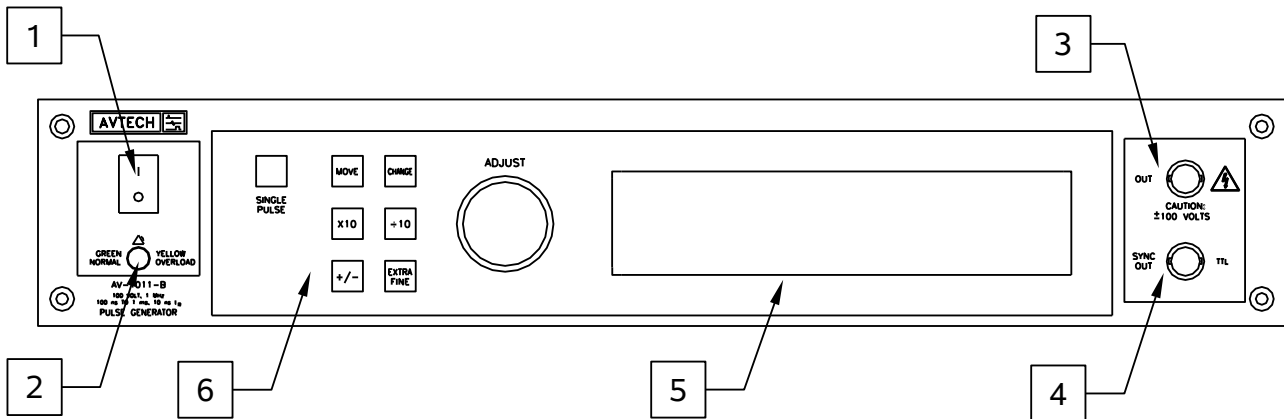

1. POWER Switch. The POWER push button switch applies AC prime power to the primaries of the transformer, turning the instrument on. The push button lamp (#382 type) is connected to the +15V DC supply.
2. OVERLOAD. The AVO-5-B is protected in its internal software against conflicting or dangerous settings. As an additional protective measure, an automatic overload circuit exists, which controls the front panel overload light. If the unit is overloaded (by operating at an exceedingly high duty cycle or by operating into a very low impedance), the protective circuit will turn the output of the instrument OFF and turn the indicator light ON. The light will stay ON (i.e. output OFF) for about 5 seconds after which the instrument will attempt to turn ON (i.e. light OFF) for about 1 second. If the overload condition persists, the instrument will turn OFF again (i.e. light ON) for another 5 seconds. If the overload condition has been removed, the instrument will turn on and resume normal operation.

This overload indicator may come on briefly at start-up. This is not a cause for concern.

Note that the output stage will safely withstand a short circuited load condition.

3. SYNC OUT. This connector supplies a SYNC output that can be used to trigger other equipment, particularly oscilloscopes. This signal leads, or lags, the main output by a duration set by the "DELAY" controls and has an approximate amplitude of +3 Volts to $R_L > 1 \text{ k}\Omega$ with a pulse width of approximately 200 ns.
4. LIQUID CRYSTAL DISPLAY (LCD). This LCD is used in conjunction with the keypad to change the instrument settings. Normally, the main menu is displayed, which lists the key adjustable parameters and their current values. The "Programming Manual for -B Instruments" describes the menus and submenus in detail.
5. KEYPAD.

Control Name	Function
--------------	----------

MOVE	This moves the arrow pointer on the display.
CHANGE	This is used to enter the submenu, or to select the operating mode, pointed to by the arrow pointer.
×10	If one of the adjustable numeric parameters is displayed, this increases the setting by a factor of ten.
÷10	If one of the adjustable numeric parameters is displayed, this decreases the setting by a factor of ten.
+/-	If one of the adjustable numeric parameters is displayed, and this parameter can be both positive or negative, this changes the sign of the parameter.
EXTRA FINE	This changes the step size of the ADJUST knob. In the extra-fine mode, the step size is twenty times finer than in the normal mode. This button switches between the two step sizes.
ADJUST	This large knob adjusts the value of any displayed numeric adjustable values, such as frequency, pulse width, etc. The adjust step size is set by the "EXTRA FINE" button. When the main menu is displayed, this knob can be used to move the arrow pointer.

REAR PANEL CONTROLS

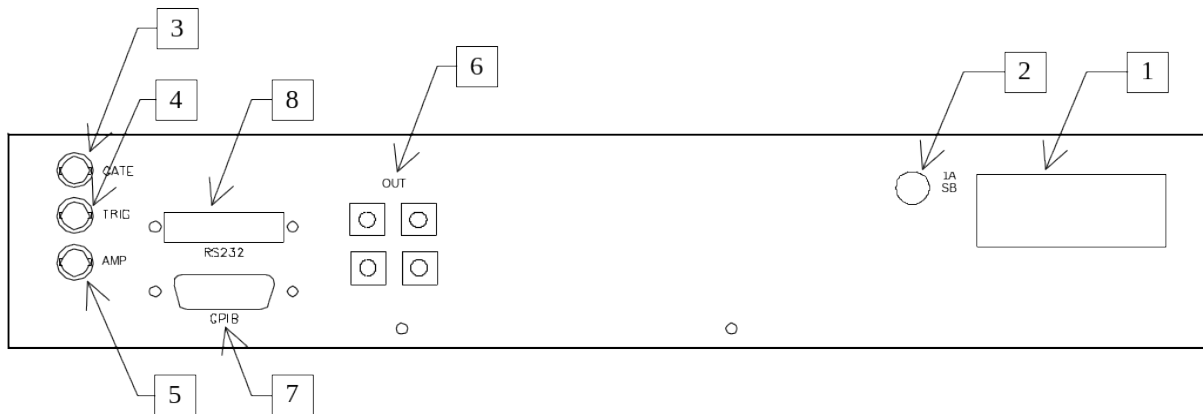

1. AC POWER INPUT. A three-pronged recessed male connector is provided on the back panel for AC power connection to the instrument. Also contained in this assembly is a 1.0A slow blow fuse and a removable card that can be removed and repositioned to switch between 120V AC in and 240V AC in.
2. 1.0A SB. This fuse protects the output stage.
3. GATE. This TTL-level (0 and +5V) logic input can be used to gate the triggering of the instrument. This input can be either active high or active low, depending on the front panel settings or programming commands. (The instrument triggers normally when this input is unconnected).
4. TRIG. This TTL-level (0 and +5V) logic input can be used to trigger the instrument, if the instrument is set to triggering externally. The instrument triggers on the rising edge of this input.
5. AMP (Optional Feature). For instrument with the “-EA” option, the amplitude may be set to track the voltage on this input. 0 Volts in corresponds to zero output amplitude, and a +10V input corresponds to maximum amplitude out.
6. OUT. This array of four connectors is the mainframe output. These connectors must be connected directly to the four connectors on the output module with the supplied RG174 cables. (“-PN” units will have two sets of output connectors; one for the positive outputs, and one for negative outputs.)
7. GPIB Connector. A standard GPIB cable can be attached to this connector to allow the instrument to be computer-controlled. See the “Programming Manual for -B Instruments” for more details on GPIB control.
8. RS-232 Connector. A standard serial cable with a 25-pin male connector can be attached to this connector to allow the instrument to be computer-controlled. See

the “Programming Manual for -B Instruments” for more details on RS-232 control.

GENERAL INFORMATION

AMPLITUDE CONTROL

The AVO-5-B consists of two parts, the mainframe and the output module. The mainframe is a voltage pulser, which, in conjunction with a transformer in the output module, generates 0 to +84V (V_{OUT}), when operating into the required 3.0 Ohm resistance. A diode load may be connected in series with this resistance, so that the current through the diode is normally given by:

$$I_{DIODE} = \frac{V_{OUT} - V_{DIODE}}{0.75\Omega}$$

where V_{DIODE} is the voltage drop across the diode.

The basic scheme for connecting the mainframe and the output module to the laser diode load is shown below:

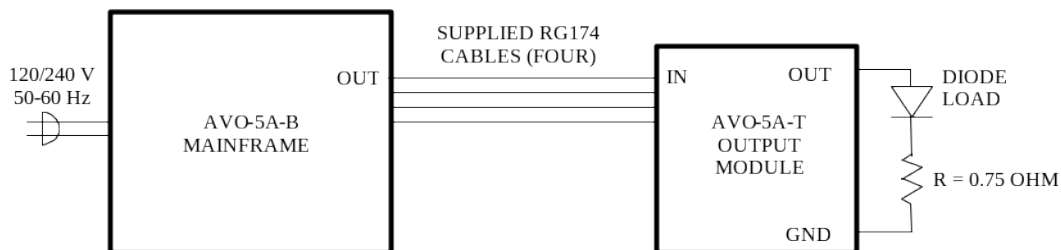

“-PN” units have a positive and a negative output on the mainframe. The output module must be connected to the appropriate mainframe output, depending on the set amplitude polarity.

A fast current probe may be used to monitor the current waveform. Factory testing is conducted using an American Laser 711S current transformer. The Tektronix CT2 current transformer can also be used, but the American Laser 711S is physically smaller.

BASIC PULSE CONTROL

This instrument can be triggered by its own internal clock or by an external TTL trigger signal. In either case, two output channels respond to the trigger: OUT and SYNC. The OUT channel is the signal that is applied to the load. Its amplitude and pulse width are variable. The SYNC pulse is a fixed-width TTL-level reference pulse used to trigger oscilloscopes or other measurement systems. When the delay is set to a positive value

the SYNC pulse precedes the OUT pulse. When the delay is set to a negative value the SYNC pulse follows the OUT pulse.

These pulses are illustrated below, assuming internal triggering, positive delay, and positive amplitude:

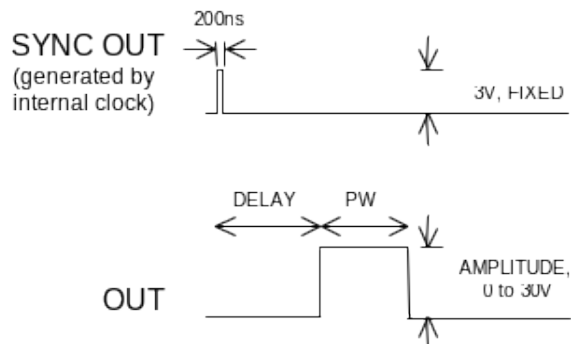

Figure A

If the delay is negative, the order of the SYNC and OUT pulses is reversed:

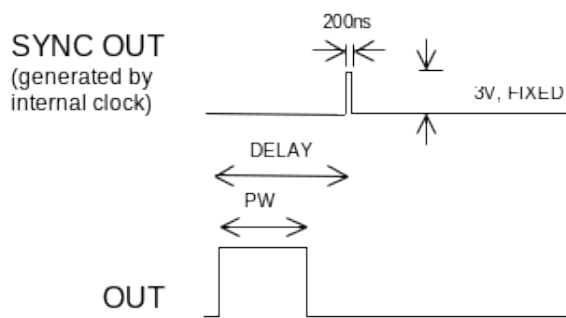

Figure B

The next figure illustrates the relationship between the signal when an external TTL-level trigger is used:

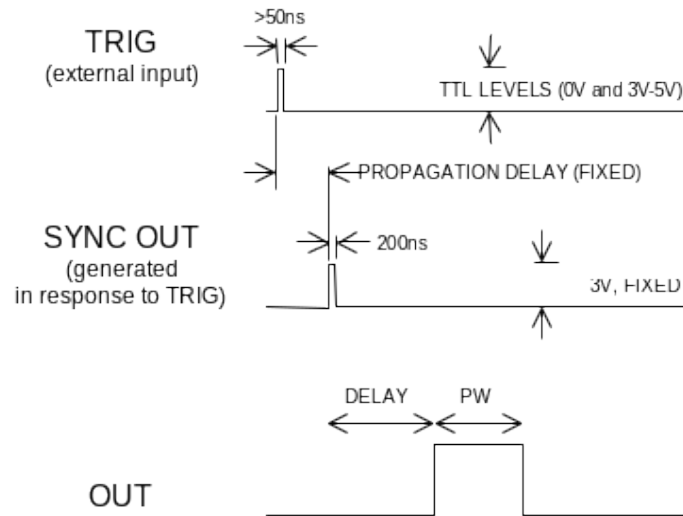

Figure C

As before, if the delay is negative, the order of the SYNC and OUT pulses is reversed.

The delay, pulse width, and frequency (when in the internal mode), of the OUT pulse can be varied with front panel controls or via the GPIB or RS-232 computer interfaces.

TRIGGER MODES

This instrument has four trigger modes:

- Internal Trigger: the instrument controls the trigger frequency, and generates the clock internally.
- External Trigger: the instrument is triggered by an external TTL-level clock on the back-panel TRIG connector.
- Manual Trigger: the instrument is triggered by the front-panel "SINGLE PULSE" pushbutton.
- Hold Trigger: the instrument is set to not trigger at all.

These modes can be selected using the front panel trigger menu, or by using the appropriate programming commands. (See the "Programming Manual for -B Instruments" for more details.)

GATING MODES

Triggering can be suppressed by a TTL-level signal on the rear-panel GATE connector. The instrument can be set to stop triggering when this input high or low, using the front-panel gate menu or the appropriate programming commands. This input can also be set to act synchronously or asynchronously. When set to asynchronous mode, the GATE will disable the output immediately. Output pulses may be truncated. When set to synchronous mode, the output will complete the full pulse width if the output is high, and then stop triggering. No pulses are truncated in this mode.

TOP COVER REMOVAL

The interior of the instrument may be accessed by removing the four Phillips screws on the top panel. With the four screws removed, the top cover may be slid back (and off).

RACK MOUNTING

A rack mounting kit is available. The -R5 rack mount kit may be installed after first removing the one Phillips screw on the side panel adjacent to the front handle.

OPERATIONAL CHECK

This section describes a sequence to confirm the basic operation of the instrument. It should be performed after receiving the instrument. It is a useful learning exercise as well.

Before proceeding with this procedure, finish read this instruction manual thoroughly. Then read the “Local Control” section of the “Programming Manual for -B Instruments” thoroughly. The “Local Control” section describes the front panel controls used in this operational check - in particular, the MOVE, CHANGE, and ADJUST controls.

1. Connect a cable from the SYNC OUT connector to the TRIG input of an oscilloscope. Connect the four IN SMA ports of the output module to the four OUT SMA ports on the rear panel of the mainframe using the supplied RG174 cables. (For “-PN” units, use the “OUT P” connectors.) Attach the laser diode anode to the output module “OUT” terminal. Connect a low-inductance 3.0 Ohm series resistance as shown below. Connect oscilloscope probe as shown. Set the oscilloscope to trigger externally.

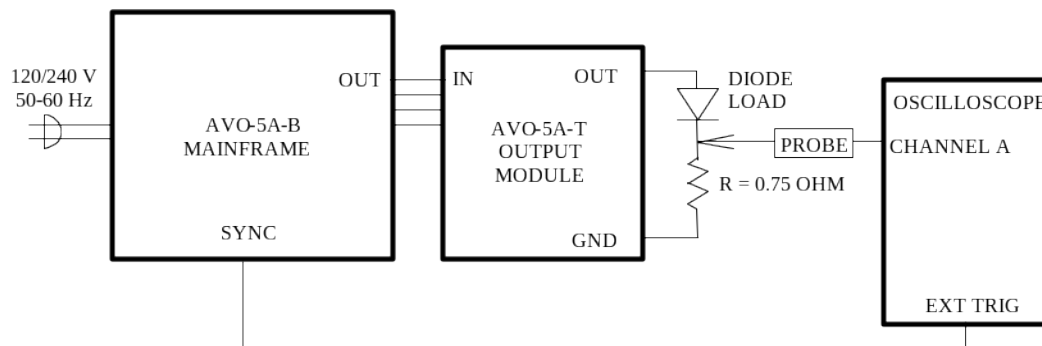

1. Turn on the AVO-5-B. The main menu will appear on the LCD.
2. To set the AVO-5-B to trigger from the internal clock at a PRF of 1 kHz:
 - a) The arrow pointer should be pointing at the frequency menu item. If it is not, press the MOVE button until it is.
 - b) Press the CHANGE button. The frequency submenu will appear. Rotate the ADJUST knob until the frequency is set at 1 kHz.
 - c) The arrow pointer should be pointing at the “Internal” choice. If it is not, press MOVE until it is.

- d) Press CHANGE to return to the main menu.
3. To set the delay to 200 ns:
 - a) Press the MOVE button until the arrow pointer is pointing at the delay menu item.
 - b) Press the CHANGE button. The delay submenu will appear. Rotate the ADJUST knob until the delay is set at 200 ns.
 - c) The arrow pointer should be pointing at the “Normal” choice. If it is not, press MOVE until it is.
 - d) Press CHANGE to return to the main menu.
 4. To set the pulse width to 100 ns:
 - a) Press the MOVE button until the arrow pointer is pointing at the pulse width menu item.
 - b) Press the CHANGE button. The pulse width submenu will appear. Rotate the ADJUST knob until the pulse width is set at 100 ns.
 - c) Press CHANGE to return to the main menu.
 5. At this point, nothing should appear on the oscilloscope.
 6. To enable the output:
 - a) Press the MOVE button until the arrow pointer is pointing at the output menu item.
 - b) Press the CHANGE button. The output submenu will appear.
 - c) Press MOVE until the arrow pointer is pointing at the “ON” choice.
 - d) Press CHANGE to return to the main menu.
 7. To change the output amplitude:
 - a) Press the MOVE button until the arrow pointer is pointing at the amplitude menu item.
 - b) Press the CHANGE button. The amplitude submenu will appear. Rotate the ADJUST knob until the amplitude is set at 84V.
 - c) Observe the oscilloscope. You should see 100 ns wide, 84V pulses.

- a) Press CHANGE to return to the main menu.
8. Repeat the last step, but set the amplitude to zero.
9. For “-PN” units, repeat all of the above steps using the “OUT N” connectors, and negative amplitude settings. Reverse the orientation of the diode to accommodate negative current.
10. This completes the operational check.

PROGRAMMING YOUR PULSE GENERATOR

KEY PROGRAMMING COMMANDS

The “Programming Manual for -B Instruments” describes in detail how to connect the pulse generator to your computer, and the programming commands themselves. A large number of commands are available; however, normally you will only need a few of these. Here is a basic sample sequence of commands that might be sent to the instrument after power-up:

*rst	(resets the instrument)
trigger:source internal	(selects internal triggering)
frequency 1000 Hz	(sets the frequency to 1000 Hz)
pulse:width 100 ns	(sets the pulse width to 100 ns)
pulse:delay 200 ns	(sets the delay to 200 ns)
volt 84	(sets the amplitude to 84 V)
output on	(turns on the output)

For triggering a single event, this sequence would be more appropriate:

*rst	(resets the instrument)
trigger:source hold	(turns off all triggering)
pulse:width 100 ns	(sets the pulse width to 100 ns)
output on	(turns on the output)
volt 84	(sets the amplitude to 84 V)
trigger:source immediate	(generates a single non-repetitive trigger event)
trigger:source hold	(turns off all triggering)
output off	(turns off the output)

To set the instrument to trigger from an external TTL input:

*rst	(resets the instrument)
trigger:source external	(selects external triggering)
pulse:width 100 ns	(sets the pulse width to 100 ns)
pulse:delay 200 ns	(sets the delay to 200 ns)
volt 84	(sets the amplitude to 84 V)
output on	(turns on the output)

These commands will satisfy 90% of your programming needs.

ALL PROGRAMMING COMMANDS

For more advanced programmers, a complete list of the available commands is given below. These commands are described in detail in the “Programming Manual for -B Instruments”. (Note: this manual also includes some commands that are not implemented in this instrument. They can be ignored.)

<u>Keyword</u>	<u>Parameter</u>	<u>Notes</u>
LOCAL		
OUTPut:		
:[STATE]	<boolean value>	
:PROTection		
:TRIPped?		[query only]
REMOTE		
[SOURce]:		
:FREQuency		
[:CW FIXed]	<numeric value>	
[SOURce]:		
:PULSe		
:PERiod	<numeric value>	
:WIDTh	<numeric value>	
:DCYClE	<numeric value>	
:HOLD	WIDTh DCYClE	
:DELay	<numeric value>	
:GATE		
:TYPE	ASYNc SYNc	
:LEVel	HIgh LOw	
[SOURce]:		
:VOLTage		
[:LEVel]		
[:IMMediate]		
[:AMPLitude]	<numeric value> EXTeRnal	
:PROTection		
:TRIPped?		[query only]
STATUS:		
:OPERation		
:[EVENT]?		[query only, always returns "0"]
:CONDition?		[query only, always returns "0"]
:ENABle	<numeric value>	[implemented but not useful]
:QUEStionable		
:[EVENT]?		[query only, always returns "0"]
:CONDition?		[query only, always returns "0"]
:ENABle	<numeric value>	[implemented but not useful]
SYSTEM:		
:COMMunicate		
:GPIB		
:ADDReSS	<numeric value>	
:SERial		
:CONTRol		
:RTS	ON IBFull RFR	
:[RECEive]		
:BAUD	1200 2400 4800 9600	
:BITS	7 8	
:ECHO	<boolean value>	

	:PARity		
	: [TYPE]	EVEN ODD NONE	
	:SBITS	1 2	
	:ERRor		
	: [NEXT]?		[query only]
	:COUNT?		[query only]
	:VERSion?		[query only]
TRIGger:			
	:SOURce	INTernal EXTernal MANual HOLD IMMEDIATE	
*CLS			[no query form]
*ESE		<numeric value>	
*ESR?			[query only]
*IDN?			[query only]
*OPC			
*SAV		0 1 2 3	[no query form]
*RCL		0 1 2 3	[no query form]
*RST			[no query form]
*SRE		<numeric value>	
*STB?			[query only]
*TST?			[query only]
*WAI			[no query form]

PERFORMANCE CHECK SHEET