

INSTRUCTIONS

MODEL AVO-5A-C-PN PULSE GENERATOR

S.N.:

### WARRANTY

Avtech Electrosystems Ltd. warrants products of its manufacture to be free from defects in material and workmanship under conditions of normal use. If, within one year after delivery to the original owner, and after prepaid return by the original owner, this Avtech product is found to be defective, Avtech shall at its option repair or replace said defective item. This warranty does not apply to units which have been disassembled, modified or subjected to conditions exceeding the applicable specifications or ratings. This warranty is the extent of the obligation assumed by Avtech with respect to this product and no other warranty or guarantee is either expressed or implied.

### TECHNICAL SUPPORT

Phone: 613-226-5772 or 1-800-265-6681

Fax: 613-226-2802 or 1-800-561-1970

E-mail: [info@avtechpulse.com](mailto:info@avtechpulse.com)

World Wide Web: <http://www.avtechpulse.com>

## TABLE OF CONTENTS

WARRANTY.....	2
TABLE OF CONTENTS.....	3
FIG. 1: PULSE GENERATOR TEST ARRANGEMENT.....	4
GENERAL OPERATING INSTRUCTIONS.....	5
FIG. 2: FRONT PANEL CONTROLS.....	9
FRONT PANEL CONTROLS.....	10
FIG. 3: BACK PANEL CONTROLS.....	12
BACK PANEL CONTROLS.....	13
TOP COVER REMOVAL AND RACK MOUNTING.....	14
POWER SUPPLY AND FUSE REPLACEMENT.....	15
PERFORMANCE CHECK SHEET.....	17

**FIG. 1: PULSE GENERATOR TEST ARRANGEMENT**

$R_L = 3 \text{ Ohm}$ , 20 Amps max (AVO-5A-TA Output Module)

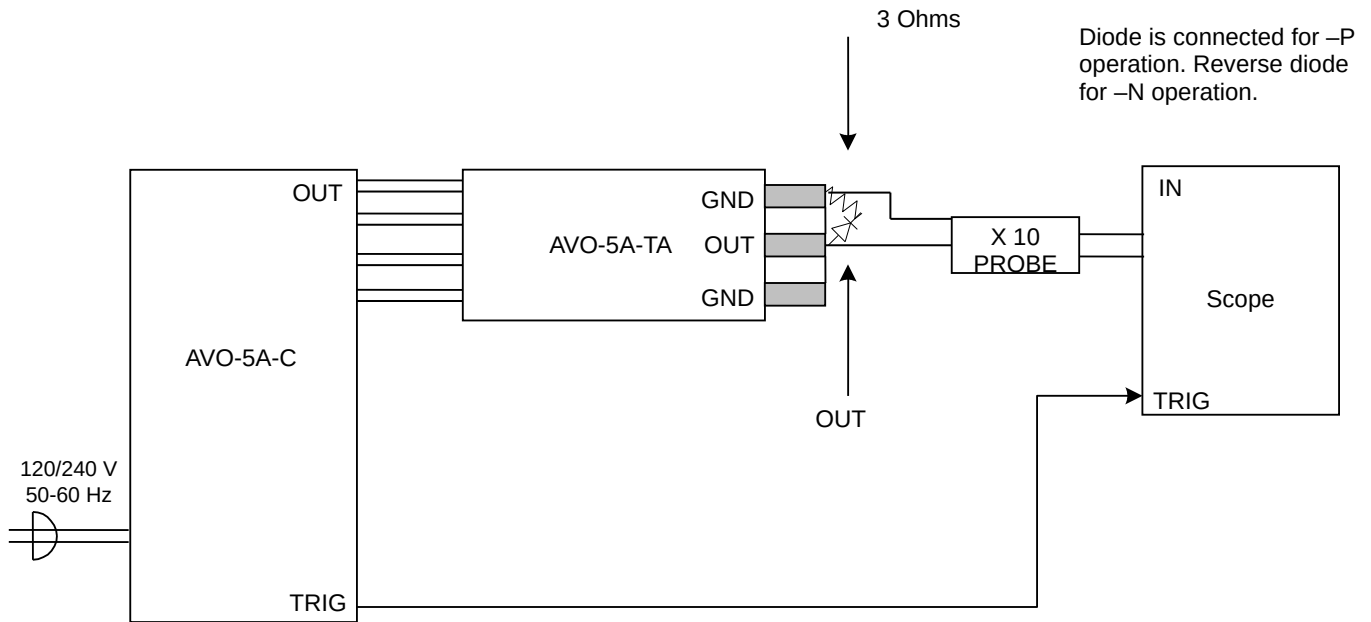

$R_L = 0.75 \text{ Ohm}$ , 40 Amps max (AVO-5A-TB Output Module)

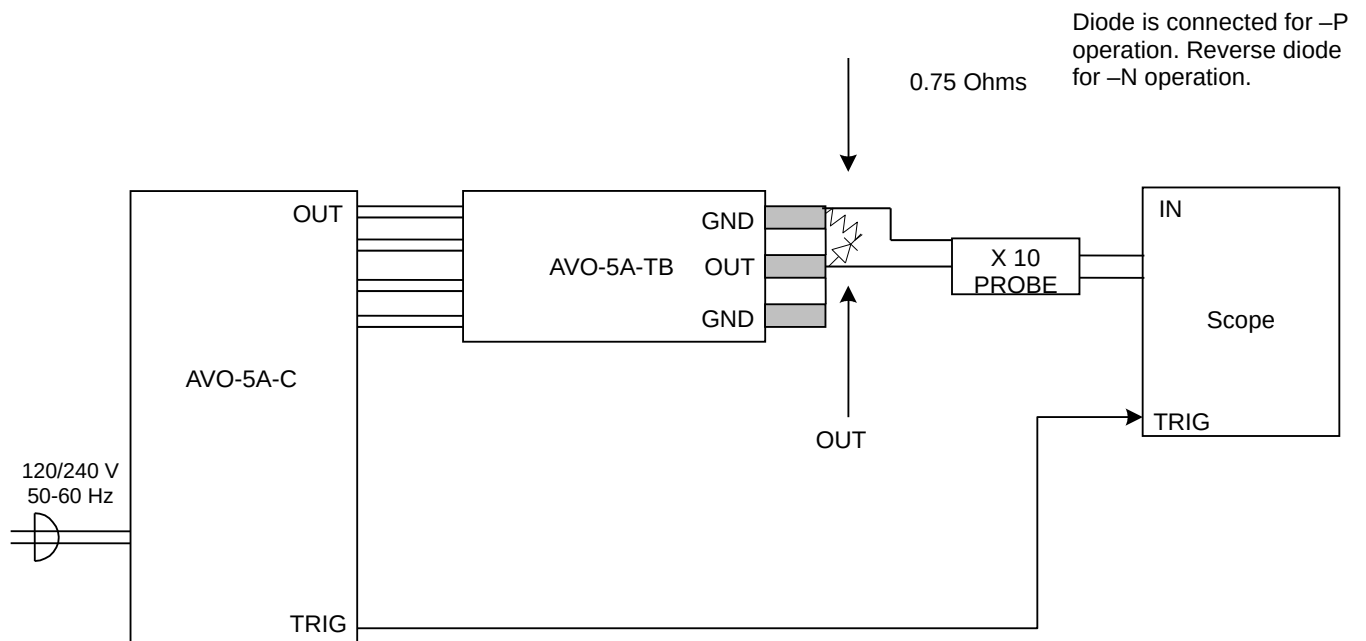

## GENERAL OPERATING INSTRUCTIONS

- 1) The bandwidth capability of components and instruments used to display the pulse generator output signal (attenuators, cables, connectors, etc.) should exceed 100 MHz.
- 2) Model AVO-5A-C is supplied with two output modules. The AVO-5A-TA module supplies up to 20 Amps to a load resistance of 3 Ohms and features shorter rise and fall times than the AVO-5A-TB module which provides up to 40 Amps to 0.75 Ohm. The load resistance values of 3 and 0.75 Ohms includes the resistance of the diode. The output module connects to the four SMA out connectors on the mainframe front panel via the four parallel RG174 cables (2 feet in length). The output terminals of the transformer module consists of a short length of microstrip transmission line protruding from the module chassis. The OUT terminal is the center conductor which is bounded on both sides by the ground plane (see below):

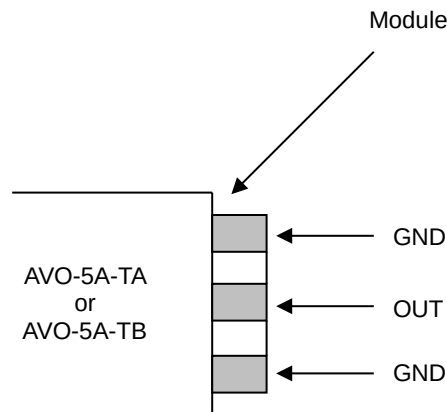

The diode load and series current limiting resistor should be connected between the OUT and GND terminals using very short leads (<0.5 cm). The series current limiting resistors must be non inductive. Carbon composition resistors are suitable for this application. The voltage across the resistor-diode load may be monitored by means of a high impedance scope probe.

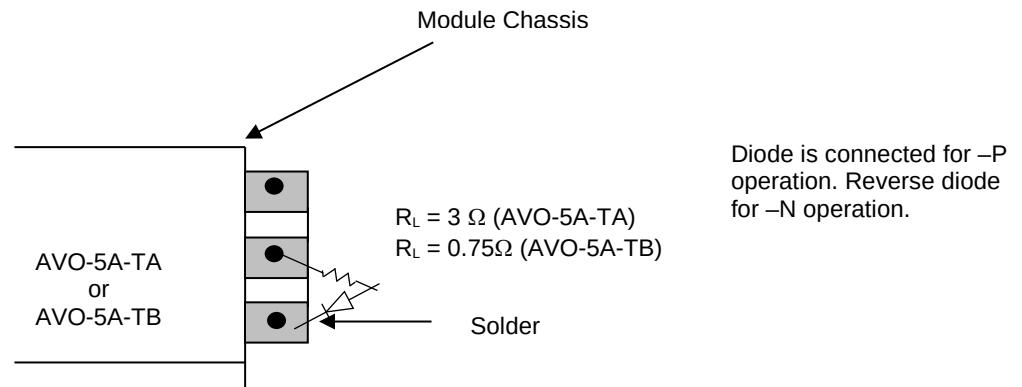

**CAUTION:** The prime power should not be applied to the mainframe unless one of the output modules is connected to the mainframe. The mainframe may be damaged if an output module is not connected.

3) The diode current may be measured or deduced as follows:

$$A. I_{DIODE} = \frac{V_{OUT} - V_{DIODE}}{R_{SERIES}}$$

Where  $V_{OUT}$  is the total voltage across the resistor-diode series connector as determined using a scope.  $V_{DIODE}$  is the voltage across the diode and is also determined using the scope.  $R_{SERIES}$  is approximately 3 Ohms (AVO-5A-TA) or 0.75 Ohms (AVO-5A-TB).

$$B. I_{DIODE} = \frac{5V_{MON} - V_{DIODE}}{R_{SERIES}} \quad (\text{For the AVO-5A-TA})$$

$$I_{DIODE} = \frac{2.5V_{MON} - V_{DIODE}}{R_{SERIES}} \quad (\text{For the AVO-5A-TB})$$

Where  $V_{MON}$  is the voltage outputted to 50 Ohms by the optional rear panel SMA monitor connector.  $V_{DIODE}$  and  $R_{SERIES}$  are as for as A above.

C. Use a current probe such as Model 711S made by Channel Island Circuits Inc. (PH: 805-964-4449) or model CT-2 made by Tektronix.

4) The TRIG output channel provides TTL level signals. The TRIG output precedes the main output when the front panel ADVANCE-DELAY switch is in the ADVANCE position. The TRIG output lags the main output when the switch is in the DELAY position.

The DELAY control controls the relative delay between the reference output pulse provided at the TRIG output and the main output. This delay is variable over the range of 0.01 us to 1.0 us.

	MIN	MAX
Range 1	0.01 us	0.1 us
Range 2	0.1 us	1.0 us

- 5) To obtain a stable output display the PRF control on the front panel should be set mid range. The front panel MODE switch should be in the INT position. The DELAY controls and the scope triggering controls are then adjusted to obtain a stable output. The scope may then be used to set the desired PRF by rotating the PRF controls.
- 6) The output pulse width is controlled by means of the front panel ten-turn PW control. Note that the MODE switch must be in the INT position.
- 7) The output pulse amplitude is controlled by means of the front panel ten-turn AMP control.
- 8) The output polarity is controlled by the two-position polarity switch. Note that to avoid stressing the output stage the amplitude should be turned down to zero before changing the position of the polarity switch. (-PN option)\_

CAUTION: To avoid damage to the diode, insure that if the polarity switch is set on positive, the diode anode must be connected to the center conductor on the output module. If the polarity switch is set on negative, the diode cathode must be connected to the center conductor.

- 9) An external clock may be used to control the output PRF of the AVO unit by setting the front panel MODE switch in the EXT position and applying a 50 ns (or wider) TTL level pulse to the TRIG BNC connector input. With the MODE switch in the EXT A position, the output pulse width will be controlled by the front panel PW controls. If the switch is in the EXT B position, the output pulse width equals the input trigger pulse width. CAUTION: Do not exceed a 200 ns pulse width.
- 10) For single pulse manual operation, set the front panel MODE switch in the MAN position and push the SINGLE PULSE button.
- 11) OVERLOAD. An automatic overload protective circuit controls the front panel overload light. If the unit is overloaded (by operating at an exceedingly high duty cycle or by operating into a very low impedance), the protective circuit will turn the output of the instrument OFF and turn the indicator light ON. The light will stay ON (i.e. output OFF) for about 5 seconds after which the instrument will attempt to turn ON (i.e. light OFF) for about 1 second. If the overload condition persists, the instrument will turn OFF again (i.e. light ON) for another 5 seconds. If the overload condition has been removed, the instrument will turn on and resume normal operation. Overload conditions

may be removed by:

- 1) Reducing PRF (i.e. switch to a lower range)
- 2) Reducing pulse width (i.e. switch to a lower range)
- 3) Removing output load short circuit (if any).
- 4) Reducing the output amplitude (i.e. switch to a lower range).

The overload light may illuminate when the prime power is first applied. The light will extinguish after a few seconds and the unit will then operate normally.

Note that the output stage will safely withstand a short-circuited load condition.

- 12) CAUTION: DC potentials as high as 200 Volts exist in the interior of the instrument. For this reason it is recommended that the top cover of the unit should not be removed and that the unit should be returned to the factory for servicing (when necessary).
- 13) The unit can be converted from 120 to 240V 50-60 Hz operation by adjusting the voltage selector card in the rear panel fused voltage selector cable connector assembly.
- 14) For further assistance:  
Tel: 613-226-5772  
Fax: 613-226-2802  
Email: [info@avtechpulse.com](mailto:info@avtechpulse.com)



FIG. 2: FRONT PANEL CONTROLS

## FRONT PANEL CONTROLS

- (1) ON-OFF Switch. Applies basic prime power to all stages.
- (2) PRF Control. Varies PRF from 0.5 Hz to 5 kHz as follows:

Range 1	0.5	Hz	5	Hz
Range 2	5	Hz	50	Hz
Range 3	50	Hz	500	Hz
Range 4	500	Hz	5	kHz

- (3) DELAY Control. Controls the relative delay between the reference output pulse provided at the TRIG output (4) and the main output (5). This delay is variable over the range of 0.01 to about 1.0 us. Delay LEADS or LAGS depending on the position of the ADVANCE-DELAY switch.

	MIN	MAX
Range 1	0.01 us	0.1 us
Range 2	0.1 us	1.0 us

- (4) TRIG Output. This output is used to trigger the scope time base. The output is a TTL level 100 ns (approx.) pulse capable of driving a fifty-Ohm load. This output precedes the output at (5) if the two-position ADVANCE-DELAY switch is in the ADVANCE position. This output follows the output at (5) if the switch is in the DELAY position. The delay range is variable from 0.01 us to 1.0 us. The external trigger signal is applied at this input when the EXT-INT toggle switch is in the EXT position.
- (5) OUT Connector. Four SMA connectors provide output to the AVO-5A-TA or AVO-5A-TB output modules.
- (6) PW Control. A ten-turn control, which varies the output pulse width from 20 ns to 200 ns (when the MODE switch is in the INT position).
- (7) AMP Control. A ten-turn control, which varies the output pulse amplitude.
- (8) MODE. With this switch in the INT position, the PRF of the AVO unit is controlled via an internal clock, which in turn is controlled by the PRF control. With the switch in the EXT position, the AVO unit requires a 50 ns (or wider) TTL level pulse applied at the TRIG input in order to trigger the output stages. In addition, in this mode, the scope time base must be triggered by the external trigger source. With the MODE switch in the EXT A position the output pulse width is controlled by the PW controls. With the MODE switch in

the EXT B position, the output pulse width equals the input trigger pulse width. **CAUTION:** Do not exceed a pulse width of 200 ns. For single pulse operation, set the MODE switch in the MAN position.

- (9) SINGLE PULSE. For single pulse manual operation, set the front panel INT-EXT-MAN switch in the MAN position and push the SINGLE PULSE button.

10) OVERLOAD. An automatic overload protective circuit controls the front panel overload light. If the unit is overloaded (by operating at an exceedingly high duty cycle or by operating into a very low impedance), the protective circuit will turn the output of the instrument OFF and turn the indicator light ON. The light will stay ON (i.e. output OFF) for about 5 seconds after which the instrument will attempt to turn ON (i.e. light OFF) for about 1 second. If the overload condition persists, the instrument will turn OFF again (i.e. light ON) for another 5 seconds. If the overload condition has been removed, the instrument will turn on and resume normal operation. Overload conditions may be removed by:

- 1) Reducing PRF (i.e. switch to a lower range)
- 2) Reducing pulse width (i.e. switch to a lower range)
- 3) Removing output load short circuit (if any)
- 4) Reducing the output amplitude (i.e. switch to a lower range)

The overload light may illuminate when the prime power is first applied. The light will extinguish after a few seconds and the unit will then operate normally.

Note that the output stage will safely withstand a short-circuited load condition.

- 11) POLARITY. The output polarity is controlled by the two-position polarity switch. Note that to avoid stressing the output stage the amplitude should be turned down to zero before changing the position of the polarity switch. (-PN option).

**CAUTION:** To avoid damage to the diode, insure that if the polarity switch is set on positive, the diode anode must be connected to the center conductor on the output module. If the polarity switch is set on negative, the diode cathode must be connected to the center conductor.

FIG. 3: BACK PANEL CONTROLS

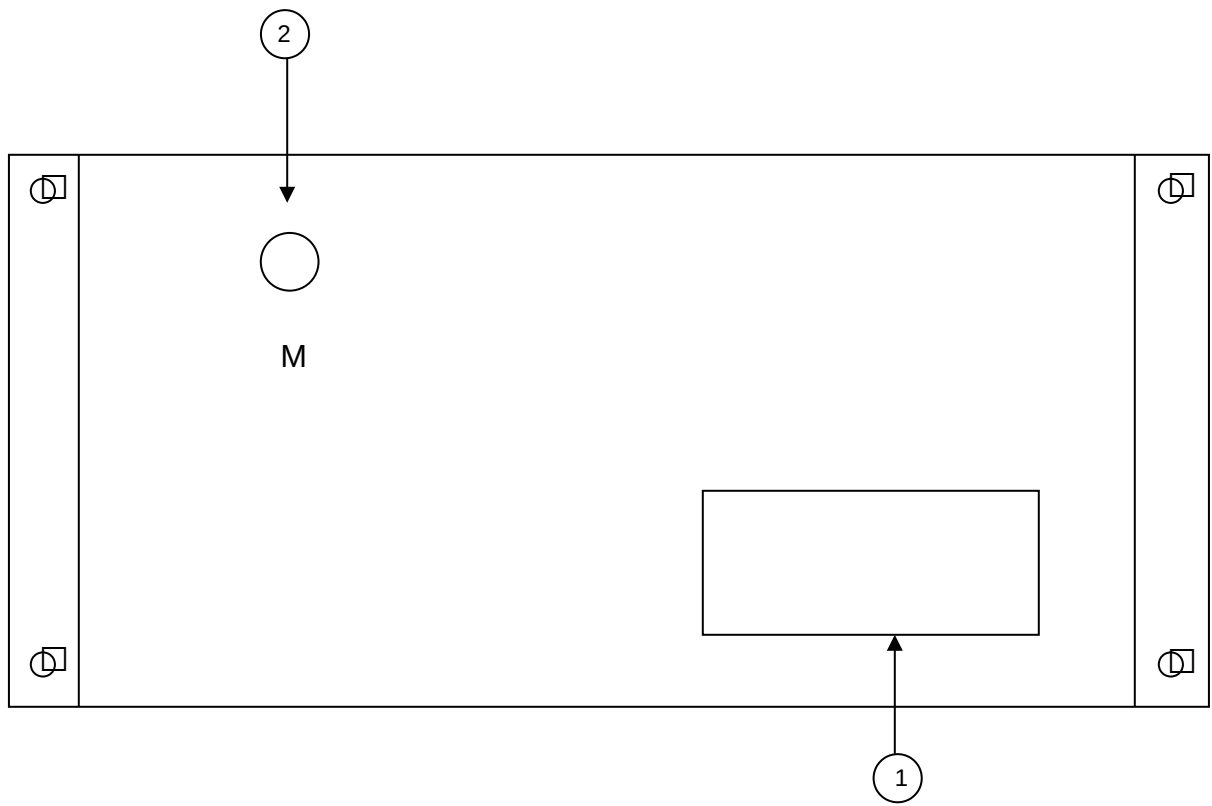

## BACK PANEL CONTROLS

- (1) FUSED CONNECTOR, VOLTAGE SELECTOR. The detachable power cord is connected at this point. In addition, the removable cord is adjusted to select the desired input operating voltage. The unit also contains the main power fuse.

For AC line voltages of 110-120V, the power selector card should be installed so that the "120" marking is visible from the rear of the instrument.

For AC line voltages of 220-240V, the power selector card should be installed so that the "240" marking is visible from the rear of the instrument.

If it is not set for the proper voltage, remove the fuse and then grasp the card with a pair of pliers and remove it. Rotate horizontally through 180 degrees. Reinstall the card and the correct fuse.

In the 120V setting, a 0.5A slow blow fuse is required. In the 240V setting, a 0.25A slow blow fuse is required.

- (2) MONITOR: SMA connector should be terminated in a 50 Ohm load when in use. The voltage at the output terminals of the AVO-5A-TA output module will be 5 times the monitor output voltage so the diode current may be determined from :

$$I_{\text{DIODE}} = \frac{5V_{\text{MON}} - V_{\text{DIODE}}}{R_{\text{SERIES}}}$$

For model AVO-5A-TB, the relationship is:

$$I_{\text{DIODE}} = \frac{2.5V_{\text{MON}} - V_{\text{DIODE}}}{R_{\text{SERIES}}}$$

### TOP COVER REMOVAL AND RACK MOUNTING

- 1) The interior of the instrument may be accessed by removing the four Phillips screws on the top panel. With the four screws removed, the top cover may be slid back (and off).
- 2) The -R5 rack mount kit may be installed after first removing the one Phillips screw on the side panel adjacent to the front handle.

## POWER SUPPLY AND FUSE REPLACEMENT

This instrument has three main fuses, plus two spares. One, which protects the AC input, is located in the rear-panel power entry module, as described in the “Rear Panel Controls” section of this manual. If the power appears to have failed, check the AC fuse first.

The other two fuses (plus two spares) are located on the internal DC power supply, as shown below:

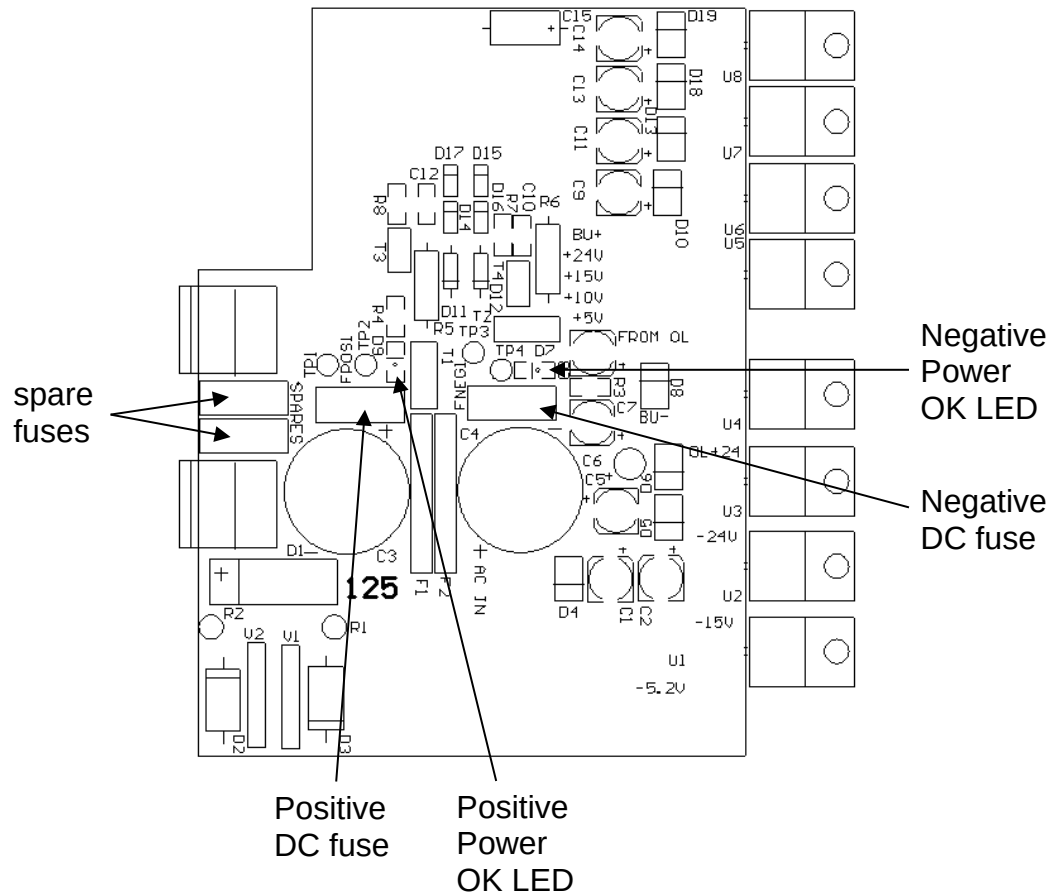

The positive fuse and one of the spare fuses on this circuit board are 1A slow-blow fuses, Littlefuse part number R452001. (This fuse can be ordered from Digikey, [www.digikey.com](http://www.digikey.com). The Digikey part number is F1343CT-ND). The negative fuse and the second spare fuse are 0.5A slow-blow fuses (Littlefuse R452.500, Digikey part number F1341CT-ND).

If you suspect that the DC fuses are blown, follow this procedure:

1. Remove the top cover, by removing the four Phillips screws on the top cover and then sliding the cover back and off.
2. Locate the two "Power OK" LEDs on the power supply circuit board, as illustrated above.
3. Turn on the instrument.
4. Observe the "Power OK" LEDs. If the fuses are not blown, the two LEDs will be lit (bright red). If one of the LEDs is not lit, the fuse next to it has blown.
5. Turn off the instrument.
6. If a fuse is blown, use needle-nose pliers to remove the blown fuse from its surface-mount holder.
7. Replace the fuse. (Spare 1 Amp and 0.5 Amp fuses are provided on the circuit board. They may be transferred to the active fuse locations using needle-nose pliers.)



PERFORMANCE CHECK SHEET