

INSTRUCTIONS

MODEL AVO-6C1-B

0 TO 5 Amp (0 to 250 Volts)
10 kHz LASER DIODE DRIVER
WITH IEEE 488.2 AND RS-232 CONTROL

SERIAL NUMBER: _____

WARRANTY

Avtech Electrosystems Ltd. warrants products of its manufacture to be free from defects in material and workmanship under conditions of normal use. If, within one year after delivery to the original owner, and after prepaid return by the original owner, this Avtech product is found to be defective, Avtech shall at its option repair or replace said defective item. This warranty does not apply to units which have been disassembled, modified or subjected to conditions exceeding the applicable specifications or ratings. This warranty is the extent of the obligation assumed by Avtech with respect to this product and no other warranty or guarantee is either expressed or implied.

TECHNICAL SUPPORT

Phone: 613-226-5772 or 1-800-265-6681

Fax: 613-226-2802 or 1-800-561-1970

E-mail: info@avtechpulse.com

World Wide Web: <http://www.avtechpulse.com>

EC DECLARATION OF CONFORMITY

We

Avtech Electrosystems Ltd.
P.O. Box 5120, Stn. F
Ottawa, Ontario
Canada K2C 3H4

declare that the AVO-6A-C-OP1B-P-M pulse generator meets the intent of Directive 89/336/EEC for Electromagnetic Compatibility. Compliance pertains to the following specifications as listed in the official Journal of the European Communities:

EN 50081-1 Emission
EN 50082-1 Immunity



TABLE OF CONTENTS

WARRANTY	2
TECHNICAL SUPPORT	2
EC DECLARATION OF CONFORMITY	3
TABLE OF CONTENTS	4
INTRODUCTION	5
SPECIFICATIONS	6
INSTALLATION	7
VISUAL CHECK	7
PLUGGING IN THE INSTRUMENT	7
LABVIEW DRIVERS	7
FRONT PANEL CONTROLS	8
REAR PANEL CONTROLS	10
GENERAL INFORMATION	12
AMPLITUDE CONTROL	12
BASIC PULSE CONTROL	13
TRIGGER MODES	15
GATING MODES	15
TOP COVER REMOVAL	15
ELECTROMAGNETIC INTERFERENCE	15
RACK MOUNTING	16
OPERATIONAL CHECK	17
PROGRAMMING YOUR PULSE GENERATOR	22
KEY PROGRAMMING COMMANDS	22
ALL PROGRAMMING COMMANDS	23
PERFORMANCE CHECK SHEET	25

INTRODUCTION

The AVO-6C1-B is a high performance, GPIB and RS232-equipped instrument capable of generating 0 to 5.0 A at repetition rates up to 10 kHz. The pulse width is variable from 50 ns to 50 μ s, and the duty cycle may be as high as 1%. Rise and fall times are fixed at less than 10 ns. The AVO-6C1-B includes an internal trigger source, but it can also be triggered or gated by an external source. A front-panel pushbutton can also be used to trigger the instrument.

The AVO-6C1-B features front panel keyboard and adjust knob control of the output pulse parameters along with a four line by 40-character backlit LCD display of the output amplitude, pulse width, pulse repetition frequency, and delay. The instrument includes memory to store up to four complete instrument setups. The operator may use the front panel or the computer interface to store a complete "snapshot" of all key instrument settings, and recall this setup at a later time.

The instrument is protected against overload conditions by an automatic control circuit. An internal power supply monitor removes the power to the output stage for five seconds if an average power overload exists. After that time, the unit operates normally for one second, and if the overload condition persists, the power is cut again. This cycle repeats until the overload is removed.

The AVO-6C1-B consists of two parts, the mainframe and the output module. The mainframe is a voltage pulser, which generates 0 to 250V (V_{OUT}). The output module contains a 49 Ω series resistance. The diode load is connected in series with this resistance, so that the current through the diode is normally given by:

$$I_{DIODE} = \frac{V_{OUT} - V_{DIODE}}{49\Omega}$$

where V_{DIODE} is the voltage drop across the diode.

An additional resistance (R_{SENSE}) can be placed in series with the load, for current monitoring purposes. In this case, the diode current is given by:

$$I_{DIODE} = \frac{V_{OUT} - V_{DIODE}}{49\Omega + R_{SENSE}}$$

Alternatively, a fast current probe may be used to monitor the current waveform. Factory testing is conducted using a Pearson model 2878 current transformer. (This technique tends to introduce less waveform distortion than the sensing resistor method.)

SPECIFICATIONS

Model:	AVO-6C1-B
Amplitude:	
"-P" units:	0 to +5.0 A (0 to +250 Volts into 49 Ohms + diode)
"-N" units:	0 to -5.0 A (0 to -250 Volts into 49 Ohms + diode)
"-PN" units:	0 to \pm 5.0 A (0 to \pm 250 Volts into 49 Ohms + diode)
Pulse width:	50 ns to 50 μ s
Rise time:	\leq 10 ns
Fall time:	\leq 10 ns
PRF:	0 Hz to 10 kHz
Computer control:	GPIB and RS-232 interfaces included
Propagation delay:	\leq 100 ns (Ext trig in to pulse out)
Jitter:	\pm 100 ps (Ext trig in to pulse out)
Trigger required:	Internal Mode: +5 Volt, 50 ns or wider (TTL)
Sync delay:	Sync out to pulse out: Variable 0 to \pm 50 μ s
Sync output:	+ 3 Volts, 200 ns, will drive 50 Ohm loads
Connectors:	Out: solder terminals, Trig: BNC, Sync: BNC, Gate: BNC, M: BMC
Power, AC:	120/240 Volts (switchable) 50 - 60 Hz
Dimensions:	Mainframe: 100 mm x 430 mm x 375 mm (3.9" x 17" x 14.8") Output Module: 41 mm x 66 mm x 76 mm (1.6" x 2.6" x 3.0")
Chassis material:	anodized aluminum, with blue plastic trim
Mounting:	Any
Temperature range:	+ 15° to + 40° C

INSTALLATION

VISUAL CHECK

After unpacking the instrument, examine to ensure that it has not been damaged in shipment. Visually inspect all connectors, knobs, liquid crystal displays (LCDs), and the handles. Confirm that a power cord, a GPIB cable, and two instrumentation manuals (this manual and the "OP1B Interface Programming Manual") are with the instrument. If the instrument has been damaged, file a claim immediately with the company that transported the instrument.

PLUGGING IN THE INSTRUMENT

Examine the rear of the instrument. There will be a male power receptacle, a fuse holder and the edge of the power selector card visible. Confirm that the power selector card is in the correct orientation.

For AC line voltages of 110-120V, the power selector card should be installed so that the "120" marking is visible from the rear of the instrument.

For AC line voltages of 220-240V, the power selector card should be installed so that the "240" marking is visible from the rear of the instrument.

If it is not set for the proper voltage, remove the fuse and then grasp the card with a pair of pliers and remove it. Rotate horizontally through 180 degrees. Reinstall the card and the correct fuse.

In the 120V setting, a 1.0A slow blow fuse is required. In the 240V setting, a 0.5A slow blow fuse is required.

LABVIEW DRIVERS

A LabVIEW driver for this instrument is available for download at the Avtech web site, at <http://www.avtechpulse.com/labview>. A copy is also available in National Instruments' Instrument Driver Library at <http://www.natinst.com/>.

FRONT PANEL CONTROLS

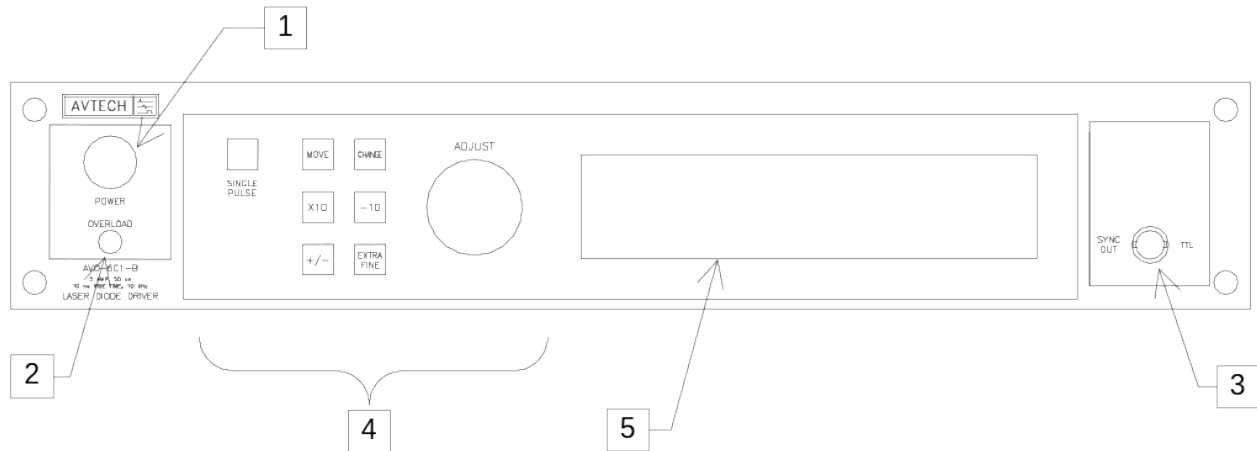

1. **POWER Switch.** The POWER push button switch applies AC prime power to the primaries of the transformer, turning the instrument on. The push button lamp (#382 type) is connected to the +15V DC supply.
2. **OVERLOAD.** The AVO-6C1-B is protected in its internal software against conflicting or dangerous settings. As an additional protective measure, an automatic overload circuit exists, which controls the front panel overload light. If the unit is overloaded (by operating at an exceedingly high duty cycle or by operating into a very low impedance), the protective circuit will turn the output of the instrument OFF and turn the indicator light ON. The light will stay ON (i.e. output OFF) for about 5 seconds after which the instrument will attempt to turn ON (i.e. light OFF) for about 1 second. If the overload condition persists, the instrument will turn OFF again (i.e. light ON) for another 5 seconds. If the overload condition has been removed, the instrument will turn on and resume normal operation.

This overload indicator may come on briefly at start-up. This is not a cause for concern.

Note that the output stage will safely withstand a short-circuited load condition.

3. **SYNC OUT.** This connector supplies a SYNC output that can be used to trigger other equipment, particularly oscilloscopes. This signal leads, or lags, the main output by a duration set by the "DELAY" controls and has an approximate amplitude of +3 Volts to $R_L > 1 \text{ k}\Omega$ with a pulse width of approximately 200 ns.

4. KEYPAD.

Control Name	Function
MOVE	This moves the arrow pointer on the display.
CHANGE	This is used to enter the submenu, or to select the operating mode, pointed to by the arrow pointer.
×10	If one of the adjustable numeric parameters is displayed, this increases the setting by a factor of ten.
÷10	If one of the adjustable numeric parameters is displayed, this decreases the setting by a factor of ten.
+/-	If one of the adjustable numeric parameters is displayed, and this parameter can be both positive or negative, this changes the sign of the parameter.
EXTRA FINE	This changes the step size of the ADJUST knob. In the extra-fine mode, the step size is twenty times finer than in the normal mode. This button switches between the two step sizes.
ADJUST	This large knob adjusts the value of any displayed numeric adjustable values, such as frequency, pulse width, etc. The adjust step size is set by the "EXTRA FINE" button. When the main menu is displayed, this knob can be used to move the arrow pointer.

5. LIQUID CRYSTAL DISPLAY (LCD). This LCD is used in conjunction with the keypad to change the instrument settings. Normally, the main menu is displayed, which lists the key adjustable parameters and their current values. The "OP1B Interface Programming Manual" describes the menus and submenus in detail.

REAR PANEL CONTROLS

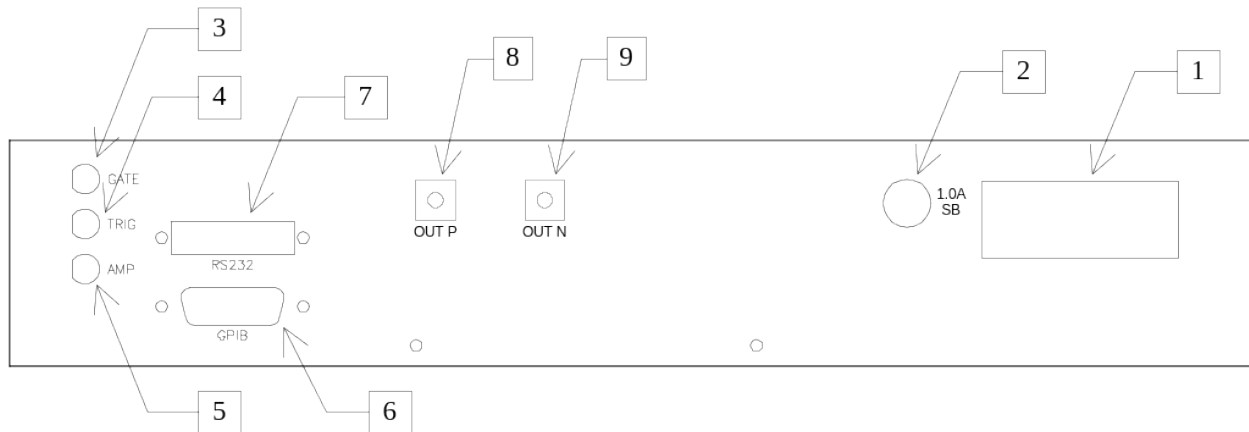

1. **AC POWER INPUT.** A three-pronged recessed male connector is provided on the back panel for AC power connection to the instrument. Also contained in this assembly are a slow-blow fuse and a removable card that can be removed and repositioned to switch between 120V AC in and 240V AC in.

For AC line voltages of 110-120V, the power selector card should be installed so that the “120” marking is visible from the rear of the instrument.

For AC line voltages of 220-240V, the power selector card should be installed so that the “240” marking is visible from the rear of the instrument.

If it is not set for the proper voltage, remove the fuse and then grasp the card with a pair of pliers and remove it. Rotate horizontally through 180 degrees. Reinstall the card and the correct fuse.

In the 120V setting, a 1.0A slow blow fuse is required. In the 240V setting, a 0.5A slow blow fuse is required.

2. **1.0A SB.** This fuse protects the output stage.
3. **GATE.** This TTL-level (0 and +5V) logic input can be used to gate the triggering of the instrument. This input can be either active high or active low, depending on the front panel settings or programming commands. (The instrument triggers normally when this input is unconnected).
4. **TRIG.** This TTL-level (0 and +5V) logic input can be used to trigger the instrument, if the instrument is set to triggering externally. The instrument triggers on the rising edge of this input.

5. AMP (Optional Feature). On units with the “-EA” option, the output amplitude can be set to track the DC voltage on this input. This input voltage may range between 0 and +10 Volts, which corresponds to minimum and maximum output amplitudes, respectively. (In normal operation, the output amplitude is set by the front-panel controls or via the computer interface.)
6. GPIB Connector. A standard GPIB cable can be attached to this connector to allow the instrument to be computer-controlled. See the “OP1B Interface Programming Manual” for more details on GPIB control.
7. RS-232 Connector. A standard serial cable with a 25-pin male connector can be attached to this connector to allow the instrument to be computer-controlled. See the “OP1B Interface Programming Manual” for more details on RS-232 control.
8. OUT P. This is the positive voltage output. This output connector is used on “-PN” units when the output polarity is positive. When used, this output is connected to the output module with the supplied RG174 cable.
9. OUT N. This is the negative voltage output. This output connector is used on “-PN” units when the output polarity is negative. When used, this output is connected to the output module with the supplied RG174 cable.

Note: Single polarity units (“-P” or “-N”) have a single “OUT” connector, which is connected to the output module with the supplied RG174 cable.

GENERAL INFORMATION

AMPLITUDE CONTROL

The AVO-6C1-B consists of two parts, the mainframe and the output module. The mainframe is a voltage pulser, which generates 0 to 250V (V_{OUT}). (“-P” units generate 0 to +250V, “-N” units generate 0 to -250V, and “-PN” units generate 0 to $\pm 250V$.) The output module contains a 49Ω series resistance. The diode load is connected in series with this resistance, so that the current through the diode is normally given by:

$$I_{DIODE} = \frac{V_{OUT} - V_{DIODE}}{49\Omega}$$

where V_{DIODE} is the voltage drop across the diode.

The functional equivalent circuit of the output module is shown below:

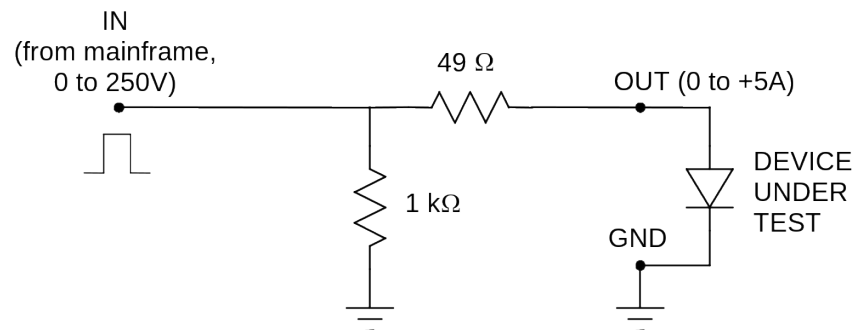

Output Module Functional Equivalent Circuit

(The equivalent circuit is shown for positive outputs. For “-N” instruments, and the negative output circuit of the dual-polarity “-PN” instruments, the polarities are negative and diodes are reversed in direction.)

An additional resistance (R_{SENSE}) can be placed in series with the diode load, for current monitoring purposes. In this case, the diode current is given by:

$$I_{DIODE} = \frac{V_{OUT} - V_{DIODE}}{49\Omega + R_{SENSE}}$$

The basic scheme for connecting the mainframe and the output module to the laser diode load is shown below:

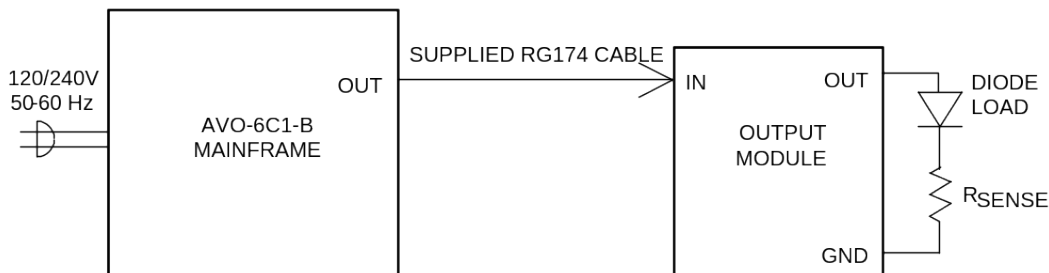

If R_{SENSE} is not used, connect the diode cathode directly to the GND terminal. (The diode is shown oriented for a positive output current.)

Alternatively, a fast current probe may be used to monitor the current waveform. Factory testing is conducted using a Pearson model 2878 current transformer. (This technique tends to introduce less waveform distortion than the sensing resistor method.)

BASIC PULSE CONTROL

This instrument can be triggered by its own internal clock or by an external TTL trigger signal. In either case, two output channels respond to the trigger: OUT and SYNC. The OUT channel is the signal that is applied to the load. Its amplitude and pulse width are variable. The SYNC pulse is a fixed-width TTL-level reference pulse used to trigger oscilloscopes or other measurement systems. When the delay is set to a positive value the SYNC pulse precedes the OUT pulse. When the delay is set to a negative value the SYNC pulse follows the OUT pulse.

These pulses are illustrated below, assuming internal triggering, positive delay, and positive amplitude:

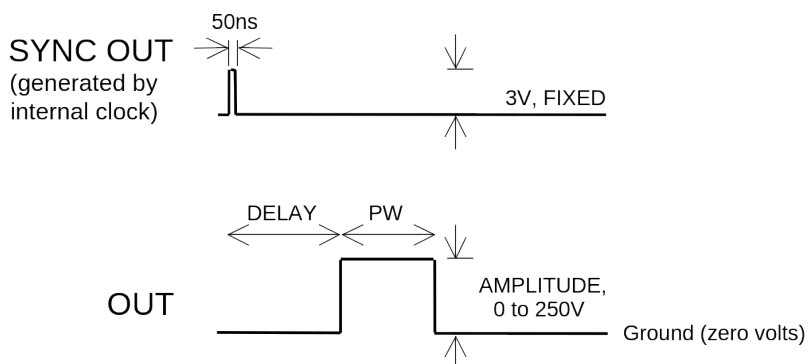

Figure A

If the delay is negative, the order of the SYNC and OUT pulses is reversed:

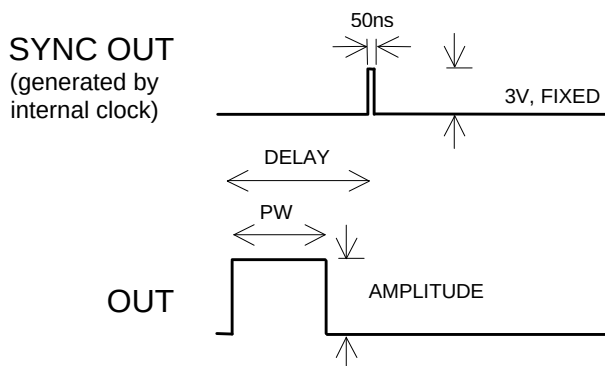

Figure B

The next figure illustrates the relationship between the signal when an external TTL-level trigger is used:

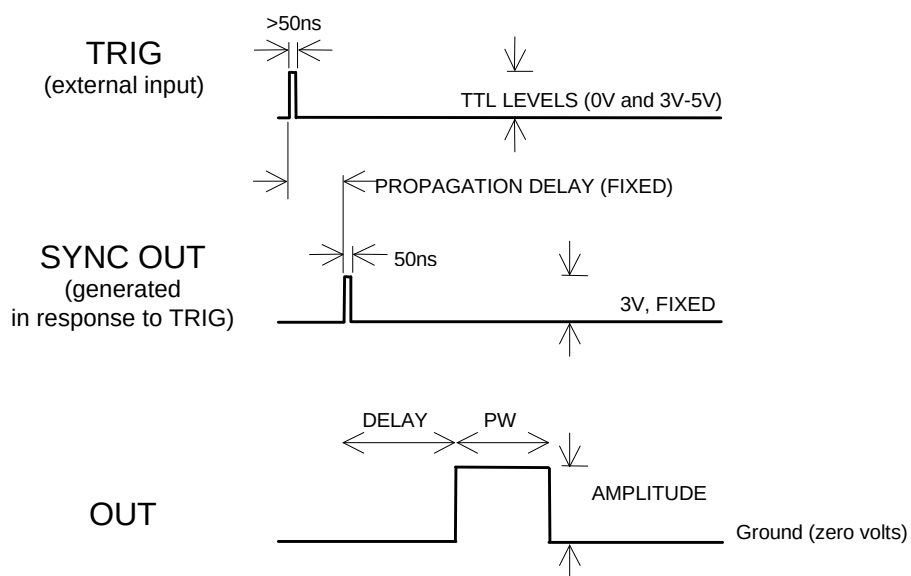

Figure C

As before, if the delay is negative, the order of the SYNC and OUT pulses is reversed.

The delay, pulse width, and frequency (when in the internal mode), of the OUT pulse can be varied with front panel controls or via the GPIB or RS-232 computer interfaces.

TRIGGER MODES

This instrument has four trigger modes:

- Internal Trigger: the instrument controls the trigger frequency, and generates the clock internally.
- External Trigger: the instrument is triggered by an external TTL-level clock on the back-panel TRIG connector.
- Manual Trigger: the instrument is triggered by the front-panel “SINGLE PULSE” pushbutton.
- Hold Trigger: the instrument is set to not trigger at all.

These modes can be selected using the front panel trigger menu, or by using the appropriate programming commands. (See the “OP1B Interface Programming Manual” for more details.)

GATING MODES

Triggering can be suppressed by a TTL-level signal on the rear-panel GATE connector. The instrument can be set to stop triggering when this input high or low, using the front-panel gate menu or the appropriate programming commands. This input can also be set to act synchronously or asynchronously. When set to asynchronous mode, the GATE will disable the output immediately. Output pulses may be truncated. When set to synchronous mode, the output will complete the full pulse width if the output is high, and then stop triggering. No pulses are truncated in this mode.

TOP COVER REMOVAL

The interior of the instrument may be accessed by removing the four Phillips screws on the top panel. With the four screws removed, the top cover may be slid back (and off).

ELECTROMAGNETIC INTERFERENCE

To prevent electromagnetic interference with other equipment, all used outputs should be connected to shielded 50 Ω loads using shielded 50 Ω coaxial cables. Unused outputs should be terminated with shielded 50 Ω BNC terminators or with shielded BNC dust caps, to prevent unintentional electromagnetic radiation. All cords and cables should be less than 3m in length.

RACK MOUNTING

A rack mounting kit is available. The -R5 rack mount kit may be installed after first removing the one Phillips screw on the side panel adjacent to the front handle.

OPERATIONAL CHECK

This section describes a sequence to confirm the basic operation of the instrument. It should be performed after receiving the instrument. It is a useful learning exercise as well.

Before proceeding with this procedure, finish read this instruction manual thoroughly. Then read the “Local Control” section of the “OP1B Interface Programming Manual” thoroughly. The “Local Control” section describes the front panel controls used in this operational check - in particular, the MOVE, CHANGE, and ADJUST controls.

For the first test, the output module is not used.

1. Connect a cable from the SYNC OUT connector to the TRIG input of an oscilloscope. Connect a 5W (or higher) 50Ω load to the OUT connector on the rear panel of the mainframe and place the scope probe across this load. Set the oscilloscope to trigger externally.

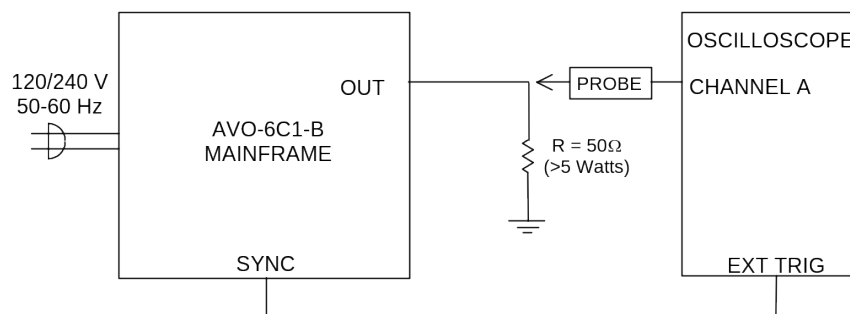

2. Turn on the AVO-6C1-B. The main menu will appear on the LCD.
3. To set the AVO-6C1-B to trigger from the internal clock at a PRF of 1 kHz:
 - The arrow pointer should be pointing at the frequency menu item. If it is not, press the MOVE button until it is.
 - Press the CHANGE button. The frequency submenu will appear. Rotate the ADJUST knob until the frequency is set at 1 kHz.
 - The arrow pointer should be pointing at the “Internal” choice. If it is not, press MOVE until it is.
 - Press CHANGE to return to the main menu.

4. To set the delay to 1 μs :
 - Press the MOVE button until the arrow pointer is pointing at the delay menu item.
 - Press the CHANGE button. The delay submenu will appear. Rotate the ADJUST knob until the delay is set at 1 μs .
 - The arrow pointer should be pointing at the “Normal” choice. If it is not, press MOVE until it is.
 - Press CHANGE to return to the main menu.
5. To set the pulse width to 1 μs :
 - Press the MOVE button until the arrow pointer is pointing at the pulse width menu item.
 - Press the CHANGE button. The pulse width submenu will appear. Rotate the ADJUST knob until the pulse width is set at 1 μs .
 - Press CHANGE to return to the main menu.
6. At this point, nothing should appear on the oscilloscope.
7. To enable the output:
 - Press the MOVE button until the arrow pointer is pointing at the output menu item.
 - Press the CHANGE button. The output submenu will appear.
 - Press MOVE until the arrow pointer is pointing at the “ON” choice.
 - Press CHANGE to return to the main menu.
8. To change the output amplitude:
 - Press the MOVE button until the arrow pointer is pointing at the amplitude menu item.
 - Press the CHANGE button. The amplitude submenu will appear. Rotate the ADJUST knob until the amplitude is set at 250V.
 - Observe the oscilloscope. You should see 1 μs wide, 250V pulses.

- Rotate the ADJUST knob. The amplitude as seen on the oscilloscope should vary.
 - Press CHANGE to return to the main menu.
9. Repeat the last step, but set the amplitude to zero.
 10. This completes the first operational check test.

For the second test, the output module is connected.

1. Connect a cable from the SYNC OUT connector to the TRIG input of an oscilloscope. Connect the IN port of the output module to the OUT port on the rear panel of the mainframe using the supplied RG174 cable. Attach the laser diode anode to the output module "OUT" terminal. Connect a Pearson 2878 current probe (or equivalent) as shown below. Place the oscilloscope probe across the 1 Ohm current-sensing resistor. Set the oscilloscope to trigger externally.

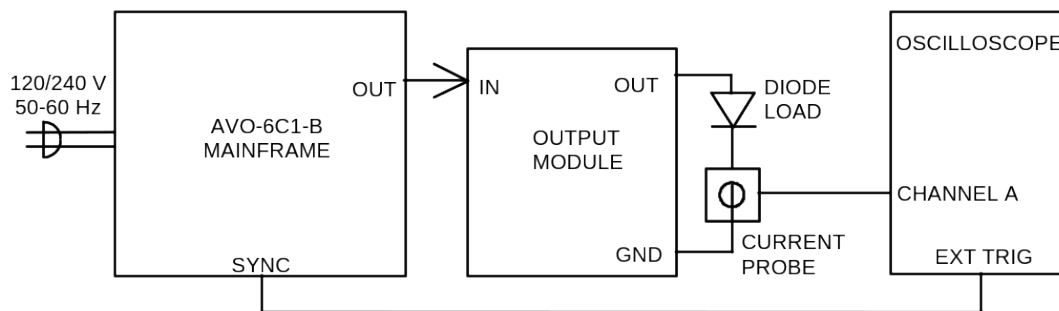

2. Turn on the AVO-6C1-B. The main menu will appear on the LCD.
3. To set the AVO-6C1-B to trigger from the internal clock at a PRF of 1 kHz:
 - The arrow pointer should be pointing at the frequency menu item. If it is not, press the MOVE button until it is.
 - Press the CHANGE button. The frequency submenu will appear. Rotate the ADJUST knob until the frequency is set at 1 kHz.
 - The arrow pointer should be pointing at the "Internal" choice. If it is not, press MOVE until it is.
 - Press CHANGE to return to the main menu.

4. To set the delay to 1 μs :
 - Press the MOVE button until the arrow pointer is pointing at the delay menu item.
 - Press the CHANGE button. The delay submenu will appear. Rotate the ADJUST knob until the delay is set at 1 μs .
 - The arrow pointer should be pointing at the “Normal” choice. If it is not, press MOVE until it is.
 - Press CHANGE to return to the main menu.
5. To set the pulse width to 1 μs :
 - Press the MOVE button until the arrow pointer is pointing at the pulse width menu item.
 - Press the CHANGE button. The pulse width submenu will appear. Rotate the ADJUST knob until the pulse width is set at 1 μs .
 - Press CHANGE to return to the main menu.
6. At this point, nothing should appear on the oscilloscope.
7. To enable the output:
 - Press the MOVE button until the arrow pointer is pointing at the output menu item.
 - Press the CHANGE button. The output submenu will appear.
 - Press MOVE until the arrow pointer is pointing at the “ON” choice.
 - Press CHANGE to return to the main menu.
8. To change the output amplitude:
 - Press the MOVE button until the arrow pointer is pointing at the amplitude menu item.
 - Press the CHANGE button. The amplitude submenu will appear. Rotate the ADJUST knob until the amplitude is set at 250V.
 - Observe the oscilloscope. You should see 1 μs wide pulses. The voltage across the current probe (Pearson 2878, Tektronix CT1 or American Laser model 711S)

should correspond to a measurement of 5 A of current. (A series-connected current-sensing resistor may also be used to measure the current, but this method often produces pronounced overshoot on the rising and falling edges. This is a measurement artefact, and is not present on the actual current waveform. This may be confirmed by using a current probe.)

- Press CHANGE to return to the main menu.
9. Repeat the last step, but set the amplitude to zero.
 10. This completes the operational check.

PROGRAMMING YOUR PULSE GENERATOR

KEY PROGRAMMING COMMANDS

The “OP1B Interface Programming Manual” describes in detail how to connect the pulse generator to your computer, and the programming commands themselves. A large number of commands are available; however, normally you will only need a few of these. Here is a basic sample sequence of commands that might be sent to the instrument after power-up:

*rst	(resets the instrument)
trigger:source internal	(selects internal triggering)
frequency 1000 Hz	(sets the frequency to 1000 Hz)
pulse:width 1 us	(sets the pulse width to 1 us)
pulse:delay 2 us	(sets the delay to 2 us)
volt 200	(sets the amplitude to 200 V)
output on	(turns on the output)

For triggering a single event, this sequence would be more appropriate:

*rst	(resets the instrument)
trigger:source hold	(turns off all triggering)
pulse:width 1 us	(sets the pulse width to 1 us)
output on	(turns on the output)
volt 200	(sets the amplitude to 200 V)
trigger:source immediate	(generates a single non-repetitive trigger event)
trigger:source hold	(turns off all triggering)
output off	(turns off the output)

To set the instrument to trigger from an external TTL input:

*rst	(resets the instrument)
trigger:source external	(selects external triggering)
pulse:width 1 us	(sets the pulse width to 1 us)
pulse:delay 2 us	(sets the delay to 2 us)
volt 200	(sets the amplitude to 200 V)
output on	(turns on the output)

These commands will satisfy 90% of your programming needs.

ALL PROGRAMMING COMMANDS

For more advanced programmers, a complete list of the available commands is given below. These commands are described in detail in the “OP1B Interface Programming Manual”. (Note: this manual also includes some commands that are not implemented in this instrument. They can be ignored.)

<u>Keyword</u>	<u>Parameter</u>	<u>Notes</u>
LOCAL		
OUTPut:		
:[STATe]	<boolean value>	
:PROTection		
:TRIPped?		[query only]
REMOTE		
[SOURce]:		
:FREQuency		
[:CW FIXed]	<numeric value>	
[SOURce]:		
:PULSe		
:PERiod	<numeric value>	
:WIDTh	<numeric value>	
:DCYCLe	<numeric value>	
:HOLD	WIDTh DCYCLe	
:DELay	<numeric value>	
:GATE		
:TYPE	ASYNc SYNc	
:LEVel	HIgh LOw	
[SOURce]:		
:VOLTage		
[:LEVel]		
[:IMMediate]		
[:AMPLitude]	<numeric value> EXTeRnal	
:PROTection		
:TRIPped?		[query only]
STATUS:		
:OPERation		
:[EVENt]?		[query only, always returns "0"]
:CONDition?		[query only, always returns "0"]
:ENABle	<numeric value>	[implemented but not useful]
:QUEStionable		
:[EVENt]?		[query only, always returns "0"]
:CONDition?		[query only, always returns "0"]
:ENABle	<numeric value>	[implemented but not useful]
SYSTEM:		
:COMMunicate		
:GPIB		
:ADDReSS	<numeric value>	
:SERial		
:CONTRol		
:RTS	ON IBFull RFR	
:[RECEive]		
:BAUD	1200 2400 4800 9600	

:BITS	7 8	
:ECHO	<boolean value>	
:PARity		
:[TYPE]	EVEN ODD NONE	
:SBITS	1 2	
:ERRor		
:[NEXT]?		[query only]
:COUNT?		[query only]
:VERSion?		[query only]
TRIGger:		
:SOURce	INTernal EXTernal MANual HOLD IMMEDIATE	
*CLS		[no query form]
*ESE	<numeric value>	
*ESR?		[query only]
*IDN?		[query only]
*OPC		
*SAV	0 1 2 3	[no query form]
*RCL	0 1 2 3	[no query form]
*RST		[no query form]
*SRE	<numeric value>	
*STB?		[query only]
*TST?		[query only]
*WAI		[no query form]

PERFORMANCE CHECK SHEET