



AVTECH ELECTROSYSTEMS LTD.

NANOSECOND WAVEFORM ELECTRONICS
SINCE 1975

P.O. BOX 265
OGDENSBURG, NY
U.S.A. 13669-0265

TEL: 888-670-8729 (USA & Canada) or +1-613-686-6675 (Intl)
FAX: 800-561-1970 (USA & Canada) or +1-613-686-6679 (Intl)

info@avtechpulse.com - <http://www.avtechpulse.com/>

BOX 5120, LCD MERIVALE
OTTAWA, ONTARIO
CANADA K2C 3H5

INSTRUCTIONS

MODEL AVO-6HF-B

250 VOLT / 5 AMP

LASER DIODE DRIVER

WITH IEEE 488.2 AND RS-232 CONTROL

SERIAL NUMBER: _____

WARRANTY

Avtech Electrosystems Ltd. warrants products of its manufacture to be free from defects in material and workmanship under conditions of normal use. If, within one year after delivery to the original owner, and after prepaid return by the original owner, this Avtech product is found to be defective, Avtech shall at its option repair or replace said defective item. This warranty does not apply to units which have been disassembled, modified or subjected to conditions exceeding the applicable specifications or ratings. This warranty is the extent of the obligation assumed by Avtech with respect to this product and no other warranty or guarantee is either expressed or implied.

TECHNICAL SUPPORT

Phone: 888-670-8729 (USA & Canada) or +1-613-686-6675 (International)

Fax: 800-561-1970 (USA & Canada) or +1-613-686-6679 (International)

E-mail: info@avtechpulse.com

World Wide Web: <http://www.avtechpulse.com>

TABLE OF CONTENTS

WARRANTY.....	2
TECHNICAL SUPPORT.....	2
TABLE OF CONTENTS.....	3
INTRODUCTION.....	5
HIGH-VOLTAGE PRECAUTIONS.....	6
SPECIFICATIONS.....	7
REGULATORY NOTES.....	8
FCC PART 18.....	8
EC DECLARATION OF CONFORMITY.....	8
DIRECTIVE 2002/95/EC (RoHS).....	9
DIRECTIVE 2002/96/EC (WEEE).....	9
AC POWER SUPPLY REGULATORY NOTES.....	10
FIRMWARE LICENSING.....	10
INSTALLATION.....	11
VISUAL CHECK.....	11
POWER RATINGS.....	11
CONNECTION TO THE POWER SUPPLY.....	11
PROTECTION FROM ELECTRIC SHOCK.....	12
ENVIRONMENTAL CONDITIONS.....	13
LABVIEW DRIVERS.....	13
FUSES.....	14
AC FUSE REPLACEMENT.....	14
DC FUSE REPLACEMENT.....	15
FUSE RATINGS.....	15
FRONT PANEL CONTROLS.....	16
REAR PANEL CONTROLS.....	18
GENERAL INFORMATION.....	20
AMPLITUDE CONTROL.....	20
LENZ'S LAW AND INDUCTIVE VOLTAGE SPIKES.....	21
BASIC TEST ARRANGEMENT - WITHOUT OUTPUT MODULE.....	21
BASIC TEST ARRANGEMENT - WITH OUTPUT MODULE.....	22
BASIC PULSE CONTROL.....	23
TRIGGER MODES.....	24

GATING MODES.....	25
OPERATIONAL CHECK.....	26
PROGRAMMING YOUR PULSE GENERATOR.....	30
KEY PROGRAMMING COMMANDS.....	30
ALL PROGRAMMING COMMANDS.....	31
MECHANICAL INFORMATION.....	33
TOP COVER REMOVAL.....	33
RACK MOUNTING.....	33
ELECTROMAGNETIC INTERFERENCE.....	33
MAINTENANCE.....	34
REGULAR MAINTENANCE.....	34
CLEANING.....	34
WIRING DIAGRAMS.....	35
WIRING OF AC POWER.....	35
WIRING OF DC POWER.....	36
PCB 158Q - LOW VOLTAGE POWER SUPPLY, 1/3.....	37
PCB 158Q - LOW VOLTAGE POWER SUPPLY, 2/3.....	38
PCB 158Q - LOW VOLTAGE POWER SUPPLY, 3/3.....	39
PCB 156D - POLARITY CONTROL PCB (-PN UNITS).....	40
PCB 197F - HIGH VOLTAGE DISCHARGE BOARD.....	41
PCB 183A-S AND 183A-P CAPACITOR BANKS.....	42
PCB 94G - ALARM BOARD.....	43
PCB 104F - KEYPAD / DISPLAY BOARD, 1/3.....	44
PCB 104F - KEYPAD / DISPLAY BOARD, 2/3.....	45
PCB 104F - KEYPAD / DISPLAY BOARD, 3/3.....	46
MAIN WIRING, POSITIVE-POLARITY (-P) UNITS.....	47
MAIN WIRING, NEGATIVE-POLARITY (-N) UNITS.....	48
MAIN WIRING, DUAL-POLARITY (-PN) UNITS.....	49
PERFORMANCE CHECK SHEET.....	50

Manual Reference: /files/server1/officefiles/instructword/avo-6/AVO-6HF-B.ed5.odt.

Last modified February 29, 2024.

Copyright © 2024 Avtech Electrosystems Ltd, All Rights Reserved.

INTRODUCTION

The AVO-6HF-B is a high performance, GPIB and RS232-equipped instrument capable of generating 0 to 5 A at repetition rates up to 100 kHz. The pulse width is variable from 50 ns to 50 us, and the duty cycle may be as high as 4%. Rise and fall times are fixed at less than 12 ns. The AVO-6HF-B includes an internal trigger source, but it can also be triggered or gated by an external source. A front-panel pushbutton can also be used to trigger the instrument.

The AVO-6HF-B features front panel keyboard and adjust knob control of the output pulse parameters along with a four line by 40-character backlit LCD display of the output amplitude, pulse width, pulse repetition frequency, and delay. The instrument includes memory to store up to four complete instrument setups. The operator may use the front panel or the computer interface to store a complete "snapshot" of all key instrument settings, and recall this setup at a later time.

The instrument is protected against overload conditions by an automatic control circuit. An internal power supply monitor removes the power to the output stage for five seconds if an average power overload exists. After that time, the unit operates normally for one second, and if the overload condition persists, the power is cut again. This cycle repeats until the overload is removed.

The AVO-6HF-B consists of two parts, the mainframe and the output module. The mainframe is a voltage pulser, which generates up to 250V (V_{OUT}). Instruments with the "-P" model suffix can generate up to +250V, whereas instruments with the "-N" model suffix can generate up to -250V. Instruments with the "-PN" suffix can generate both polarities.

The fan-cooled output module contains a 50 Ω series resistance, and packaged diodes may be soldered to the output terminals of this module. The diode load is connected in series with the internal resistance, so that the current through the diode is normally given by:

$$I_{DIODE} = (V_{OUT} - V_{DIODE}) / (50\Omega + R_{DIODE})$$

where V_{DIODE} is the voltage drop across the diode and R_{DIODE} is the parasitic resistance of the diode. These values must be selected such that I_{DIODE} never exceeds 5A.

For chip-level testing, the output module is not used. In this case, a user-supplied resistance of 50 Ohms should be connected in series with the chip, near the chip, and the voltage waveform from the mainframe should be connected to the resistor/diode series combination using coaxial cabling and/or coaxial probes. The resistance must be capable of dissipating up to 50 Watts of average power, if the AVO-6HF-B is to be used over its full range of capabilities.

This instrument is intended for use in research, development, test and calibration laboratories by qualified personnel.

HIGH-VOLTAGE PRECAUTIONS

 **CAUTION:** This instrument provides output voltages as high as 250 Volts under normal operating conditions, and generates > 250V internally, so extreme caution must be employed when using this instrument. The instrument should only be used by individuals who are thoroughly skilled in high voltage laboratory techniques. The following precautions should always be observed:

1. Keep exposed high-voltage wiring to an absolute minimum.
2. Wherever possible, use shielded connectors and cabling.
3. Connect and disconnect loads and cables only when the instrument is turned off.
4. Keep in mind that all cables, connectors, oscilloscope probes, and loads must have an appropriate voltage rating.

Do not attempt any repairs on the instrument, beyond the fuse replacement procedures described in this manual. Contact Avtech technical support (see page 2 for contact information) if the instrument requires servicing.

SPECIFICATIONS

Model:	AVO-6HF-B ¹
Maximum amplitude ² :	5 Amps
Pulse width (FWHM):	50 ns - 50 us
Rise & fall time (20%-80%):	≤ 12 ns
Maximum PRF:	100 kHz
Duty cycle (max):	4.00%
Polarity ³ :	Positive or negative or both (specify)
Output impedance:	50 Ohms
Propagation delay:	≤ 150 ns (Ext trig in to pulse out)
Jitter:	≤ ± 100 ps ± 0.03% of sync delay (Ext trig in to pulse out)
Trigger modes:	Internal trigger, external trigger (TTL-level pulse, > 10 ns, 1 kΩ input impedance), front-panel "Single Pulse" pushbutton, or single pulse trigger via computer command.
Variable delay:	Sync to main output: 0 to ±1.0 seconds, for all trigger modes (including external trigger).
Sync output:	> +3 Volts, > 50 ns, will drive 50 Ohm loads
Gate input:	Synchronous or asynchronous, active high or low, switchable. Suppresses triggering when active.
Monitor output:	Optional ⁵ . Provides an attenuated coincident replica of output voltage.
GPIO, RS-232 control ² :	Standard on -B units.
Ethernet port, for remote control using VXI-11.3, ssh, telnet, & web:	Optional ⁶ . Recommended as a modern alternative to GPIO / RS-232. See http://www.avtechpulse.com/options/vxi for details.
Settings resolution:	The resolution of the timing parameters (pulse width, delay, period) varies, but is always better than 0.15% of (set value + 20 ns). The amplitude resolution is < 0.1% of the maximum amplitude.
Settings accuracy:	Typically ± 3% (plus ±1V or ± 3 ns) after 10 minute warmup, at low duty cycles ⁸ . For high-accuracy applications requiring traceable calibration, verify the output parameters with a calibrated oscilloscope.
Output connectors, standard:	Solder terminals.
Optional output device sockets:	The standard solder terminals can be replaced by a plug-in or screw-in socket. See http://www.avtechpulse.com/laser-bias/avx-s1 for examples. Contact Avtech (info@avtechpulse.com) with your special device mounting requirement.
Optional alternative output connector and cable (AVO-6D-B only):	-CLZ option ⁷ : The output can be provided on a DB-9 male connector (Pins 1-5 = signal, pins 6-9 = ground), suitable for use with the Avtech AV-CLZ11 series of low impedance cables. Includes one AV-CLZ11-100 cable and one AV-CTLX DB-9-to-PCB adapter (see http://www.avtechpulse.com/transmission/av-clz11 and http://www.avtechpulse.com/accessories/av-ctlx for details.) The cable must be terminated by a user-supplied 11-13 Ohm resistance (or resistance in series with a diode).
Connectors, other:	BNC
Power requirements:	100 - 240 Volts, 50 - 60 Hz
Dimensions: (H x W x D)	Mainframe: 100mm x 430 mm x 375mm (3.9" x 17" x 14.8") Output module: 150 mm x 150 mm x 150 mm (6" x 6" x 6")
Chassis material:	Cast aluminum frame and handles, blue vinyl on aluminum cover plates
Mounting:	Any
Temperature range:	+5°C to +40°C

- 1) -B suffix indicates IEEE-488.2 GPIO and RS-232 control of amplitude and frequency. See <http://www.avtechpulse.com/gpio/> for details.
- 2) For operation at amplitudes of less than 20% of full-scale, best results will be obtained by setting the amplitude near full-scale and using external attenuators on the output (between the mainframe and the output module).
- 3) Indicate desired polarity by suffixing model number with -P or -N (i.e. positive or negative) or -PN for dual polarity.
- 4) For DC offset option suffix model number with -OS. Not available for the models AVO-6HF-B, AVO-6HZ-B, or AVO-6C1-B (50 us models).
- 5) For monitor option add suffix -M.
- 6) Add the suffix -VXI to the model number to specify the Ethernet port.
- 7) Add the suffix -CLZ to the model number to specify this output arrangement. For the AVO-6D-B only.
- 8) The amplitude may decrease ~10% relative to the programmed setting if the instrument is operating at or near the maximum specified duty cycle.

REGULATORY NOTES

FCC PART 18

This device complies with part 18 of the FCC rules for non-consumer industrial, scientific and medical (ISM) equipment.

This instrument is enclosed in a rugged metal chassis and uses a filtered power entry module (where applicable). The main output signal is provided on a shielded connector that is intended to be used with shielded coaxial cabling and a shielded load. Under these conditions, the interference potential of this instrument is low.

If interference is observed, check that appropriate well-shielded cabling is used on the output connectors. Contact Avtech (info@avtechpulse.com) for advice if you are unsure of the most appropriate cabling. Also, check that your load is adequately shielded. It may be necessary to enclose the load in a metal enclosure.

If any of the connectors on the instrument are unused, they should be covered with shielded metal "dust caps" to reduce the interference potential.

This instrument does not normally require regular maintenance to minimize interference potential. However, if loose hardware or connectors are noted, they should be tightened. Contact Avtech (info@avtechpulse.com) if you require assistance.

EC DECLARATION OF CONFORMITY



We Avtech Electrosystems Ltd.
 P.O. Box 5120, LCD Merivale
 Ottawa, Ontario
 Canada K2C 3H5

declare that this pulse generator meets the intent of Directive 2004/108/EG for Electromagnetic Compatibility. Compliance pertains to the following specifications as listed in the official Journal of the European Communities:

EN 50081-1 Emission

EN 50082-1 Immunity

and that this pulse generator meets the intent of the Low Voltage Directive 72/23/EEC as amended by 93/68/EEC. Compliance pertains to the following specifications as listed in the official Journal of the European Communities:

EN 61010-1:2001 Safety requirements for electrical equipment for measurement, control, and laboratory use

DIRECTIVE 2002/95/EC (RoHS)

This instrument is exempt from Directive 2002/95/EC of the European Parliament and of the Council of 27 January 2003 on the Restriction of the use of certain Hazardous Substances (RoHS) in electrical and electronic equipment. Specifically, Avtech instruments are considered "Monitoring and control instruments" (Category 9) as defined in Annex 1A of Directive 2002/96/EC. The Directive 2002/95/EC only applies to Directive 2002/96/EC categories 1-7 and 10, as stated in the "Article 2 - Scope" section of Directive 2002/95/EC.

DIRECTIVE 2002/96/EC (WEEE)

European customers who have purchased this equipment directly from Avtech will have completed a "WEEE Responsibility Agreement" form, accepting responsibility for WEEE compliance (as mandated in Directive 2002/96/EC of the European Union and local laws) on behalf of the customer, as provided for under Article 9 of Directive 2002/96/EC.

Customers who have purchased Avtech equipment through local representatives should consult with the representative to determine who has responsibility for WEEE compliance. Normally, such responsibilities will lie with the representative, unless other arrangements (under Article 9) have been made.

Requirements for WEEE compliance may include registration of products with local governments, reporting of recycling activities to local governments, and financing of recycling activities.



AC POWER SUPPLY REGULATORY NOTES

This instrument converts the AC input power to the +24V DC voltage that powers the internal circuitry of this instrument using a Tamura AAD130SD-60-A switching power supply. According to the manufacturer, the Tamura AAD130SD-60-A has the following certifications:

UL60950-1
IEC60950 -1
CSA C22.2 No. 60950- 1
EN60950 -1

and is compliant with:

EN61000-3-2
EN61000-4-2 Level 2
EN61000-4-2 Level 3 (Air Only)
EN61000-4-4 Level 3
EN61000-4-5 Level 3
EN61000-4-11
CISPR 11 and 22 FCC Part 15 Class B (conducted)

FIRMWARE LICENSING

Instruments with firmware versions 5.00 or higher use open-source software internally. Some of this software requires that the source code be made available to the user as a condition of its licensing. This source code is available upon request (contact info@avtechpulse.com).

Earlier firmware versions do not contain any open source software.

INSTALLATION

VISUAL CHECK

After unpacking the instrument, examine to ensure that it has not been damaged in shipment. Visually inspect all connectors, knobs, liquid crystal displays (LCDs), and the handles. Confirm that a power cord, a GPIB cable, and two instrumentation manuals (this manual and the “Programming Manual for -B Instruments”) are with the instrument. Confirm that an output module is supplied, with a length of coaxial cable to connect it to the mainframe. If the instrument has been damaged, file a claim immediately with the company that transported the instrument.

POWER RATINGS

This instrument is intended to operate from 100 - 240 V, 50 - 60 Hz.

The maximum power consumption is 125 Watts. Please see the “FUSES” section for information about the appropriate AC and DC fuses.

This instrument is an “Installation Category II” instrument, intended for operation from a normal single-phase supply.

CONNECTION TO THE POWER SUPPLY

An IEC-320 three-pronged recessed male socket is provided on the back panel for AC power connection to the instrument. One end of the detachable power cord that is supplied with the instrument plugs into this socket. The other end of the detachable power cord plugs into the local mains supply. Use only the cable supplied with the instrument. The mains supply must be earthed, and the cord used to connect the instrument to the mains supply must provide an earth connection. (The supplied cord does this.)

 Warning: Failure to use a grounded outlet may result in injury or death due to electric shock. This product uses a power cord with a ground connection. It must be connected to a properly grounded outlet. The instrument chassis is connected to the ground wire in the power cord.

The table below describes the power cord that is normally supplied with this instrument, depending on the destination region:

Destination Region	Description	Option	Manufacturer	Part Number
United Kingdom, Hong Kong, Singapore, Malaysia	BS 1363, 230V, 50 Hz	-AC00	Qualtek	370001-E01
Australia, New Zealand	AS 3112:2000, 230-240V, 50 Hz	-AC01	Qualtek	374003-A01
Continental Europe, Korea, Indonesia, Russia	European CEE 7/7 "Schuko" 230V, 50 Hz	-AC02	Qualtek	364002-D01
North America, Taiwan	NEMA 5-15, 120V, 60 Hz	-AC03	Qualtek	312007-01
Switzerland	SEV 1011, 230V, 50 Hz	-AC06	Qualtek	378001-E01
South Africa, India	SABS 164-1, 220-250V, 50 Hz	-AC17	Volex	2131H 10 C3
Japan	JIS 8303, 100V, 50-60 Hz	-AC18	Qualtek	397002-01
Israel	SI 32, 220V, 50 Hz	-AC19	Qualtek	398001-01
China	GB 1002-1, 220V, 50 Hz	-AC22	Volex	2137H 10 C3

PROTECTION FROM ELECTRIC SHOCK

 Operators of this instrument must be protected from electric shock at all times. The owner must ensure that operators are prevented access and/or are insulated from every connection point. In some cases, connections must be exposed to potential human contact. Operators must be trained to protect themselves from the risk of electric shock. This instrument is intended for use by qualified personnel who recognize shock hazards and are familiar with safety precautions required to avoid possibly injury. In particular, operators should:

1. Keep exposed high-voltage wiring to an absolute minimum.
2. Wherever possible, use shielded connectors and cabling.
3. Connect and disconnect loads and cables only when the instrument is turned off.
4. Keep in mind that all cables, connectors, oscilloscope probes, and loads must have an appropriate voltage rating.
5. Do not attempt any repairs on the instrument, beyond the fuse replacement procedures described in this manual. Contact Avtech technical support (see page 2 for contact information) if the instrument requires servicing. Service is to be performed solely by qualified service personnel.

ENVIRONMENTAL CONDITIONS

This instrument is intended for use under the following conditions:

1. indoor use;
2. altitude up to 2 000 m;
3. temperature 5 °C to 40 °C;
4. maximum relative humidity 80 % for temperatures up to 31 °C decreasing linearly to 50 % relative humidity at 40 °C;
5. Mains supply voltage fluctuations up to ± 10 % of the nominal voltage;
6. no pollution or only dry, non-conductive pollution.

LABVIEW DRIVERS

A LabVIEW driver for this instrument is available for download on the Avtech web site, at <http://www.avtechpulse.com/labview>. A copy is also available in National Instruments' Instrument Driver Library at <http://www.natinst.com/>.

FUSES

This instrument contains four fuses. All are accessible from the rear-panel. Two protect the AC prime power input, and two protect the internal DC power supplies. The locations of the fuses on the rear panel are shown in the figure below:



AC FUSE REPLACEMENT

To physically access the AC fuses, the power cord must be detached from the rear panel of the instrument. The fuse drawer may then be extracted using a small flat-head screwdriver, as shown below:

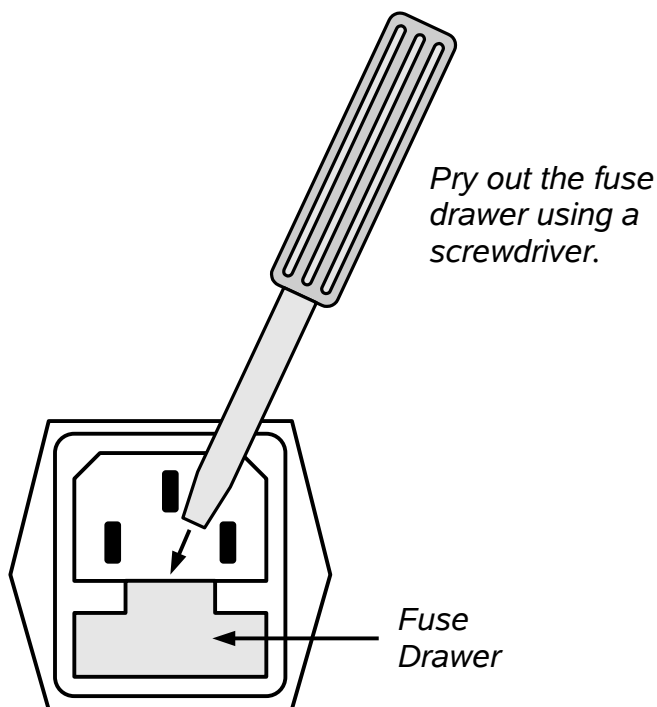

DC FUSE REPLACEMENT

The DC fuses may be replaced by inserting the tip of a flat-head screwdriver into the fuse holder slot, and rotating the slot counter-clockwise. The fuse and its carrier will then pop out.

FUSE RATINGS

The following table lists the required fuses:

Fuses	Nominal Mains Voltage	Rating	Case Size	Recommended Replacement Part	
				Littelfuse Part Number	Digi-Key Stock Number
#1, #2 (AC)	115 V	1.6A, 250V, Time-Delay	5×20 mm	021801.6HXP	F2424-ND
	230 V	0.8A, 250V, Time-Delay	5×20 mm	0218.800HXP	F2418-ND
#3 (DC)	N/A	1.0A, 250V, Time-Delay	5×20 mm	0218001.HXP	F2419-ND
#4 (DC)	N/A	3.15A, 250V, Time-Delay	5×20 mm	02183.15HXP	F2430-ND

The recommended fuse manufacturer is Littelfuse (<http://www.littelfuse.com>).

Replacement fuses may be easily obtained from Digi-Key (<http://www.digikey.com>) and other distributors.

FRONT PANEL CONTROLS

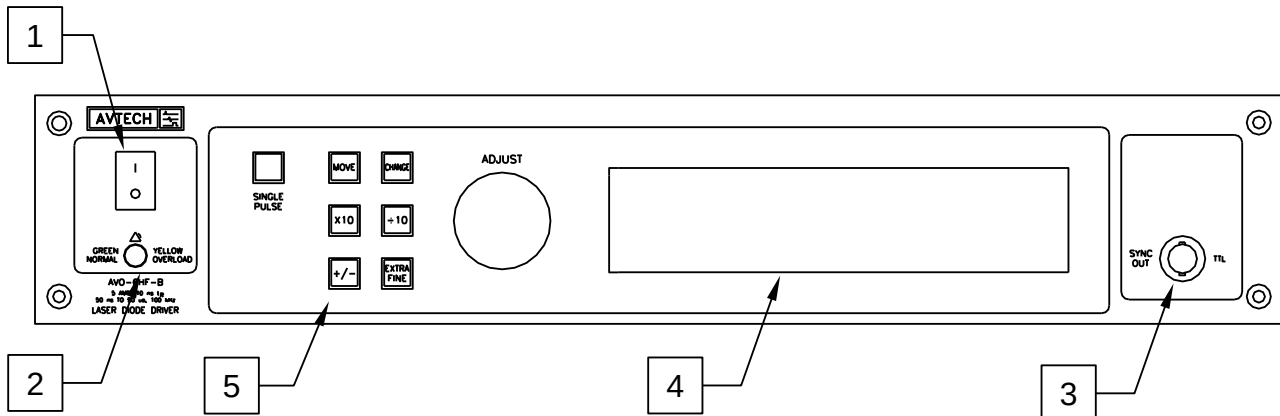

1. POWER Switch. This is the main power switch. When turning the instrument on, there is normally a delay of 10 seconds before anything is shown on the main display, as the internal operating system boots up.

If the main menu does not appear after 30 seconds, turn off the instrument and leave it off for at least 60 seconds before applying power again.

2. OVERLOAD Indicator. When the instrument is powered, this indicator is normally green, indicating normal operation. If this indicator is yellow, an internal automatic overload protection circuit has been tripped. If the unit is overloaded (by operating at an exceedingly high duty cycle or by operating into a very low impedance), the protective circuit will disable the output of the instrument and turn the indicator light yellow. The light will stay yellow (i.e. output disabled) for about 5 seconds after which the instrument will attempt to re-enable the output (i.e. light green) for about 1 second. If the overload condition persists, the output will be disabled again (i.e. light yellow) for another 5 seconds. If the overload condition has been removed, the instrument will resume normal operation.

This overload indicator may flash yellow briefly at start-up. This is not a cause for concern.

3. SYNC OUT. This connector supplies a SYNC output that can be used to trigger other equipment, particularly oscilloscopes. This signal leads (or lags) the main output by a duration set by the "DELAY" controls and has an approximate amplitude of +3 Volts to $R_L > 1k\Omega$ with a pulse width of approximately 100 ns.
4. LIQUID CRYSTAL DISPLAY (LCD). This LCD is used in conjunction with the keypad to change the instrument settings. Normally, the main menu is displayed, which lists the key adjustable parameters and their current values. The "Programming Manual for -B Instruments" describes the menus and submenus in detail.

5. KEYPAD.

Control Name	Function
MOVE	This moves the arrow pointer on the display.
CHANGE	This is used to enter the submenu, or to select the operating mode, pointed to by the arrow pointer.
×10	If one of the adjustable numeric parameters is displayed, this increases the setting by a factor of ten.
÷10	If one of the adjustable numeric parameters is displayed, this decreases the setting by a factor of ten.
+/-	If one of the adjustable numeric parameters is displayed, and this parameter can be both positive or negative, this changes the sign of the parameter.
EXTRA FINE	This changes the step size of the ADJUST knob. In the extra-fine mode, the step size is twenty times finer than in the normal mode. This button switches between the two step sizes.
ADJUST	This large knob adjusts the value of any displayed numeric adjustable values, such as frequency, pulse width, etc. The adjust step size is set by the "EXTRA FINE" button. When the main menu is displayed, this knob can be used to move the arrow pointer.

REAR PANEL CONTROLS

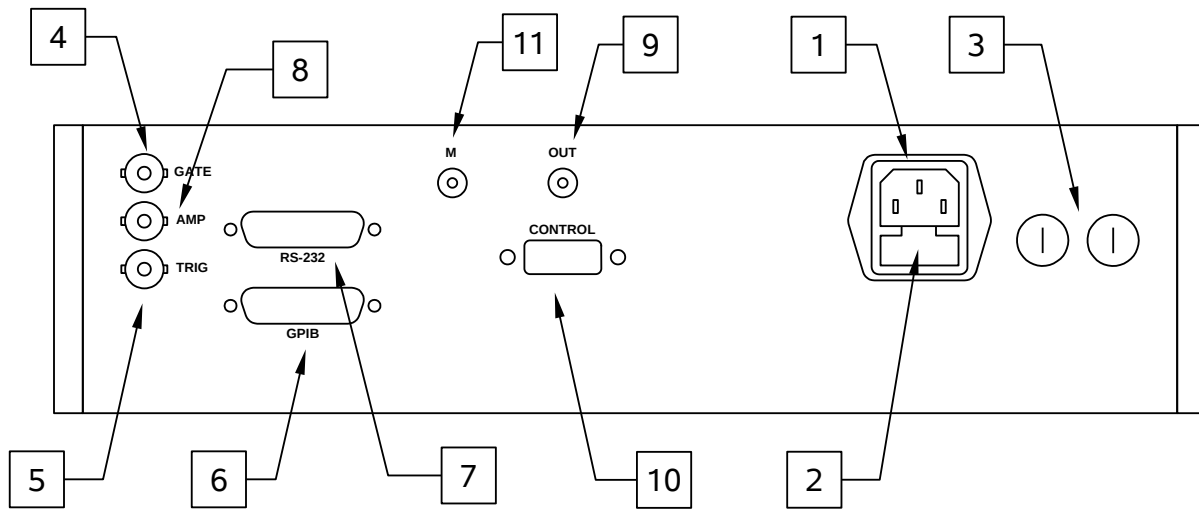

1. AC POWER INPUT. An IEC-320 C14 three-pronged recessed male socket is provided on the back panel for AC power connection to the instrument. One end of the detachable power cord that is supplied with the instrument plugs into this socket.
2. AC FUSE DRAWER. The two fuses that protect the AC input are located in this drawer. Please see the “FUSES” section of this manual for more information.
3. DC FUSES. These two fuses protect the internal DC power supplies. Please see the “FUSES” sections of this manual for more information.
4. GATE. This TTL-level (0 and +5V) logic input can be used to gate the triggering of the instrument. This input can be either active high or active low, depending on the front panel settings or programming commands. (The instrument triggers normally when this input is unconnected). When set to active high mode, this input is pulled-down to ground by a 1 k Ω resistor. When set to active low mode, this input is pulled-up to +5V by a 1 k Ω resistor.
5. TRIG. This TTL-level (0 and +5V) logic input can be used to trigger the instrument, if the instrument is set to triggering externally. The instrument triggers on the rising edge of this input. The input impedance of this input is 1 k Ω . (Depending on the length of cable attached to this input, and the source driving it, it may be desirable to add a coaxial 50 Ohm terminator to this input to provide a proper transmission line termination. The Pasternack (www.pasternack.com) PE6008-50 BNC feed-thru 50 Ohm terminator is suggested for this purpose.)

When triggering externally, the instrument can be set such that the output pulse width tracks the pulse width on this input, or the output pulse width can be set

independently.

6. GPIB Connector. A standard GPIB cable can be attached to this connector to allow the instrument to be computer-controlled. See the “Programming Manual for -B Instruments” for more details on GPIB control.
7. RS-232 Connector. A standard serial cable with a 25-pin male connector can be attached to this connector to allow the instrument to be computer-controlled. A user name (“admin”) and a password (“default”, as shipped from the factory) are required when logging into a serial terminal session. The internal controller attempts to auto-sense the parity setting. It may be necessary to send a few return characters before attempting a login in order to provide enough data to allow this auto-sensing to work. (A standard Linux “agetty” process is used to implement serial control internally.) See the “Programming Manual for -B Instruments” for more details on RS-232 control.
8. AMP Connector. (Optional feature. Present on "-EA" units only.) The output amplitude can be set to track the voltage on this input. Zero Volts in corresponds to zero amplitude output, and +10V in corresponds to maximum amplitude out. This mode is activated by selecting "Ext Control" on the front-panel amplitude menu, or with the "source:voltage external" command.
9. OUT CONNECTOR. This SMA connector is connected to the output module, when the output module is used to drive a diode load. If the output module is not used, this output will generate up to 250V into a load impedance of 50Ω.

 Caution: Voltages as high as 250V may be present on the center conductor of this output connector. Avoid touching this conductor. Connect to this connector using standard coaxial cable, to ensure that the center conductor is not exposed.
10. CONTROL Connector. This DB-9 female connector should be connected to the corresponding connector on the output module using the supplied DB-9 cable. This cable contains the wiring for the output module cooling fan and the output module thermistor.
11. M Connector. (Optional feature. Present on "-M" units only.) The monitor output provides an attenuated replica (-20 dB, ÷ 10) of the voltage on the main output. The monitor output is designed to operate into a 50 Ohm load.

GENERAL INFORMATION

AMPLITUDE CONTROL

The AVO-6HF-B consists of two parts, the mainframe and the output module. The mainframe is a voltage pulser, which generates up to 250V (V_{OUT}).

The fan-cooled output module contains a 50Ω series resistance (capable of dissipating up to 50 Watts of average power), and packaged diodes may be soldered to the output terminals of this module. The diode load is connected in series with the internal resistance, so that the current through the diode is normally given by:

$$I_{DIODE} = (V_{OUT} - V_{DIODE}) / (50\Omega + R_{DIODE})$$

where V_{DIODE} is the voltage drop across the diode and R_{DIODE} is the parasitic resistance of the diode. These values must be selected such that I_{DIODE} never exceeds 5A.

The functional equivalent circuit of the output module is shown below:

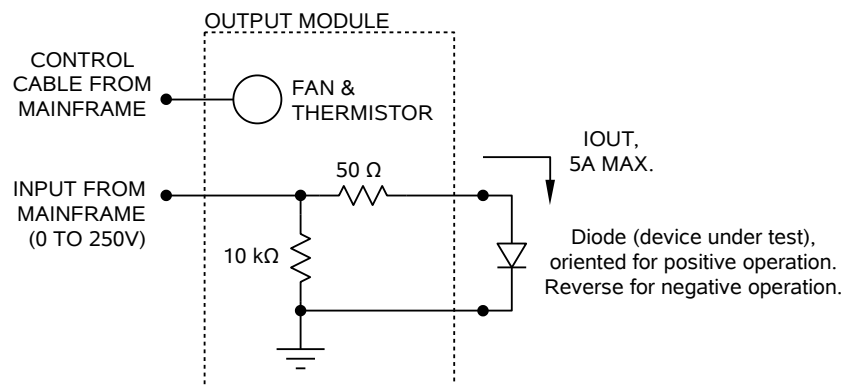

Output Module Functional Equivalent Circuit

An additional resistance (R_{SENSE}) can be placed in series with the diode load, for current monitoring purposes. In this case, the diode current is given by:

$$I_{DIODE} = (V_{OUT} - V_{DIODE}) / (50\Omega + R_{DIODE} + R_{SENSE})$$

Alternatively, a fast current probe may be used to monitor the current waveform. Factory testing is conducted using a Tektronix CT2 or Pearson 2878 current transformer. (This technique tends to introduce less waveform distortion than the sensing resistor method. However, AC-coupled current probes such as the CT2 will not be able to operate at pulse widths of more than a few microseconds. The 2878 does operate to 50 us, the maximum pulse width of the AVO-6HF-B.)

For chip-level testing, the output module is not used. In this case, a user-supplied resistance of 50 Ohms should be connected in series with the chip, near the chip, and the voltage waveform from the mainframe should be connected to the resistor/diode series combination using coaxial cabling and/or coaxial probes. Care must be taken to ensure that the resistor do not overheat. The resistance must be capable of dissipating up to 50 Watts of average power, if the AVO-6HF-B is to be used over its full range of capabilities.

LENZ'S LAW AND INDUCTIVE VOLTAGE SPIKES

This instrument is designed to pulse resistive and diode loads and will exhibit a large output spike when used to drive a load with significant inductance (as predicted by LENZ'S LAW). For this reason the load should be connected to the output using low inductance leads (as short as possible).

The voltage developed across an inductance L (in Henries), when the current is changing at a rate given by di_{LOAD} / dt (in Amps/sec), is: $V_{SPIKE} = L di_{LOAD} / dt$.

BASIC TEST ARRANGEMENT - WITHOUT OUTPUT MODULE

The AVO-6HF-B can be tested initially without the supplied output module. If the output module is not used, the mainframe output generates up to 250 Volts, into a 50 Ohm load, as illustrated below:

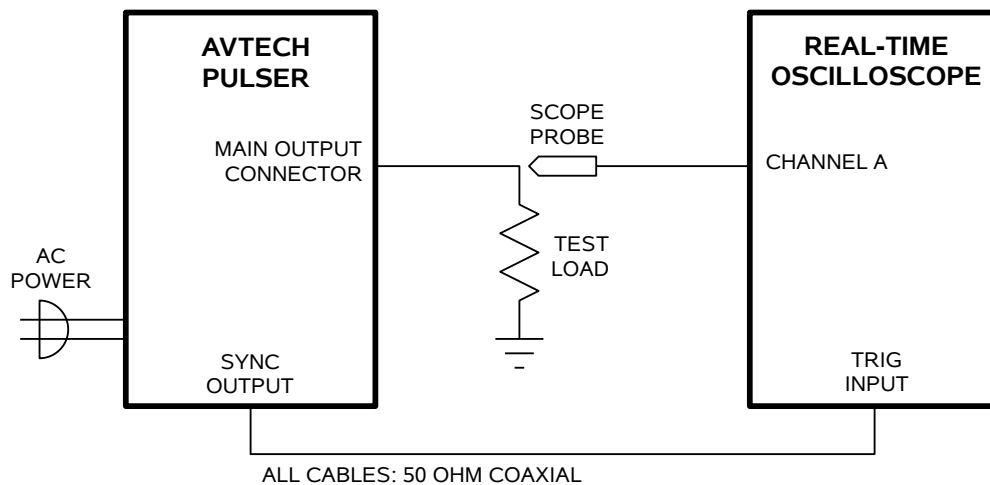

The load resistor must have a voltage rating of at least 250V, and a power rating of at least 50 Watts. It must also be low-inductance, or the waveform will become distorted and exhibit noticeable ringing.

BASIC TEST ARRANGEMENT - WITH OUTPUT MODULE

To fully test the instrument, and for normal operation, the output module must be connected as shown below:

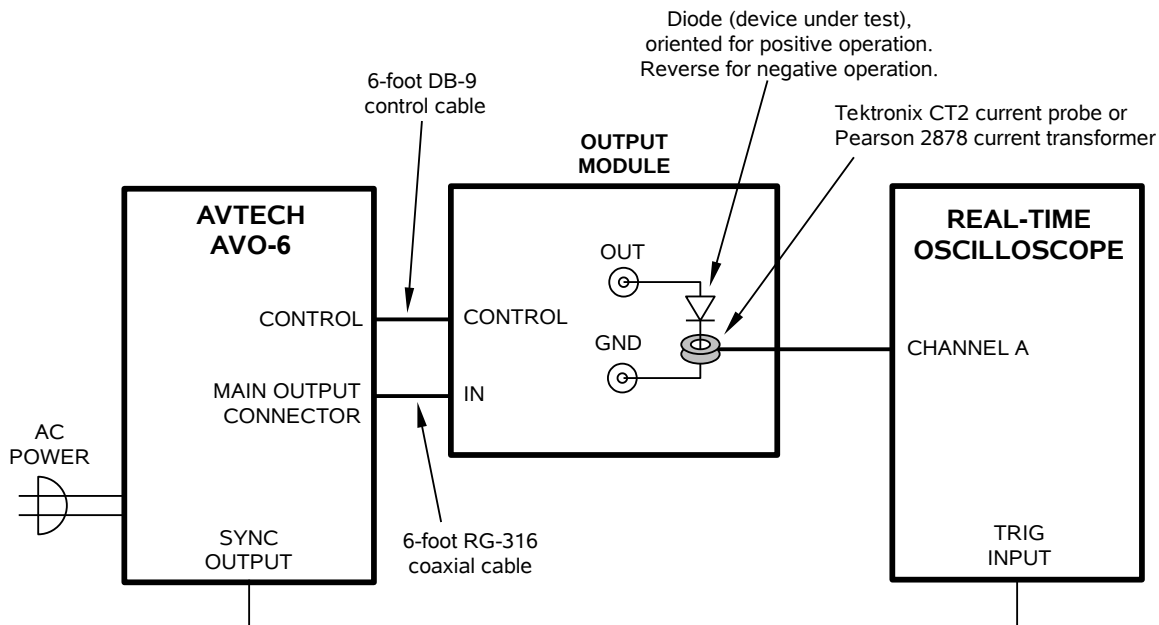

If a Tektronix CT2 current probe or Pearson 2878 current transformer is not available to measure the output current waveform, or the output pulses are too wide, a 1 Ohm resistor may be used to sense the current instead. However, noticeable ringing and distortion may appear on the waveform if this technique is used. This alternative test arrangement is shown below:

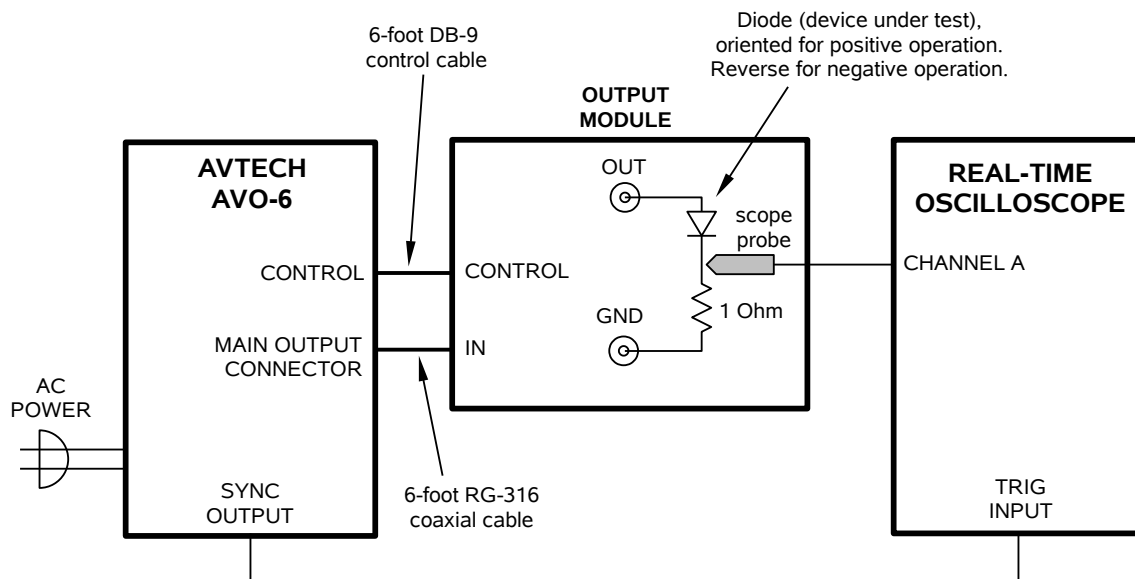

If the AVO-6HF-B is operated at its maximum duty cycle, the worst-case power dissipation in the output module is $(250V \times 5A \times 4\%) = 50$ Watts. The internal fan must have sufficient external ventilation to cool the module. The DB-9 control cable must be connected as shown above for the fan to operate.

BASIC PULSE CONTROL

This instrument can be triggered by its own internal clock or by an external TTL trigger signal. In either case, two output channels respond to the trigger: OUT and SYNC. The OUT channel is the signal that is applied to the load. Its amplitude and pulse width are variable. The SYNC pulse is a fixed-width TTL-level reference pulse used to trigger oscilloscopes or other measurement systems. When the delay is set to a positive value the SYNC pulse precedes the OUT pulse. When the delay is set to a negative value the SYNC pulse follows the OUT pulse.

These pulses are illustrated below, assuming internal triggering and a positive delay:

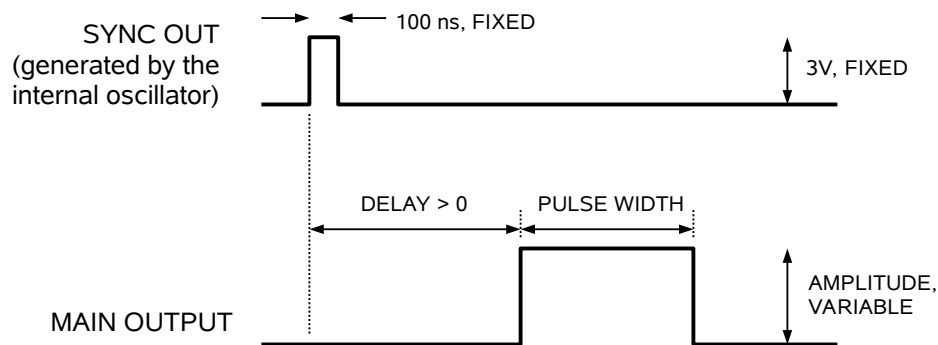

Figure A

If the delay is negative, the order of the SYNC and OUT pulses is reversed:

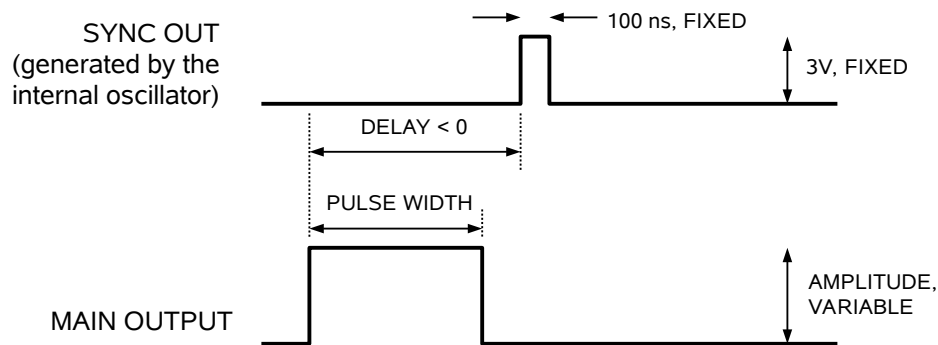

Figure B

The next figure illustrates the relationship between the signal when an external TTL-level trigger is used:

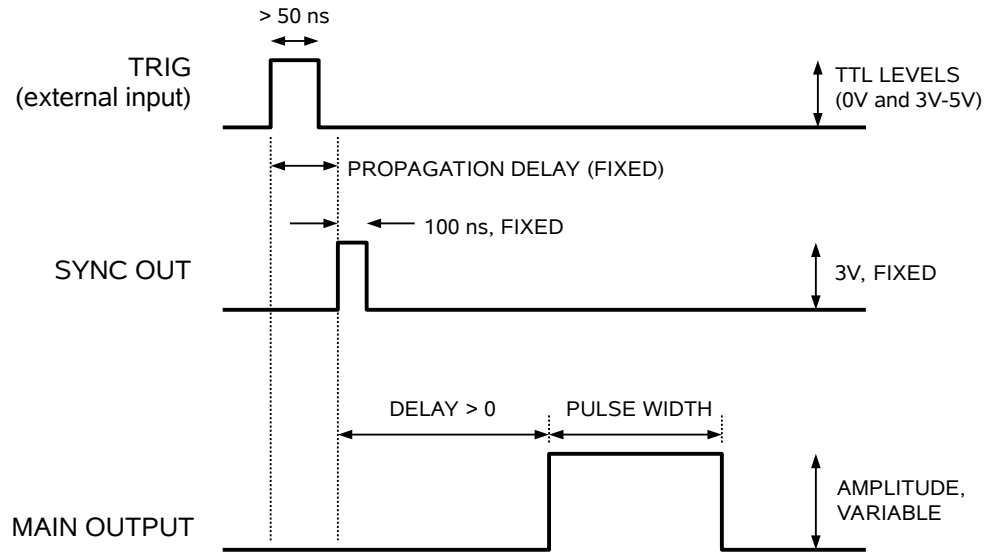

Figure C

As before, if the delay is negative, the order of the SYNC and OUT pulses is reversed.

The delay, pulse width, and frequency (when in the internal mode), of the OUT pulse can be varied with front panel controls or via the GPIB or RS-232 computer interfaces.

TRIGGER MODES

This instrument has four trigger modes:

- Internal Trigger: the instrument controls the trigger frequency, and generates the clock internally.
- External Trigger: the instrument is triggered by an external TTL-level clock on the back-panel TRIG connector.
- Manual Trigger: the instrument is triggered by the front-panel "SINGLE PULSE" pushbutton.
- Hold Trigger: the instrument is set to not trigger at all.

These modes can be selected using the front panel trigger menu, or by using the appropriate programming commands. (See the "Programming Manual for -B Instruments" for more details.)

GATING MODES

Triggering can be suppressed by a TTL-level signal on the rear-panel GATE connector. The instrument can be set to stop triggering when this input high or low, using the front-panel gate menu or the appropriate programming commands. This input can also be set to act synchronously or asynchronously. When set to asynchronous mode, the GATE will disable the output immediately. Output pulses may be truncated. When set to synchronous mode, the output will complete the full pulse width if the output is high, and then stop triggering. No pulses are truncated in this mode.

OPERATIONAL CHECK

This section describes a sequence to confirm the basic operation of the instrument. It should be performed after receiving the instrument. It is a useful learning exercise as well.

Before proceeding with this procedure, finish read this instruction manual thoroughly. Then read the “Local Control” section of the “Programming Manual for -B Instruments” thoroughly. The “Local Control” section describes the front panel controls used in this operational check - in particular, the MOVE, CHANGE, and ADJUST controls.

For the first test, the output module is not used.

1. Connect a cable from the SYNC OUT connector to the TRIG input of an oscilloscope. Connect a 50W (or higher) 50Ω load to the OUT connector on the rear panel of the mainframe and place the scope probe across this load. Set the oscilloscope to trigger externally.

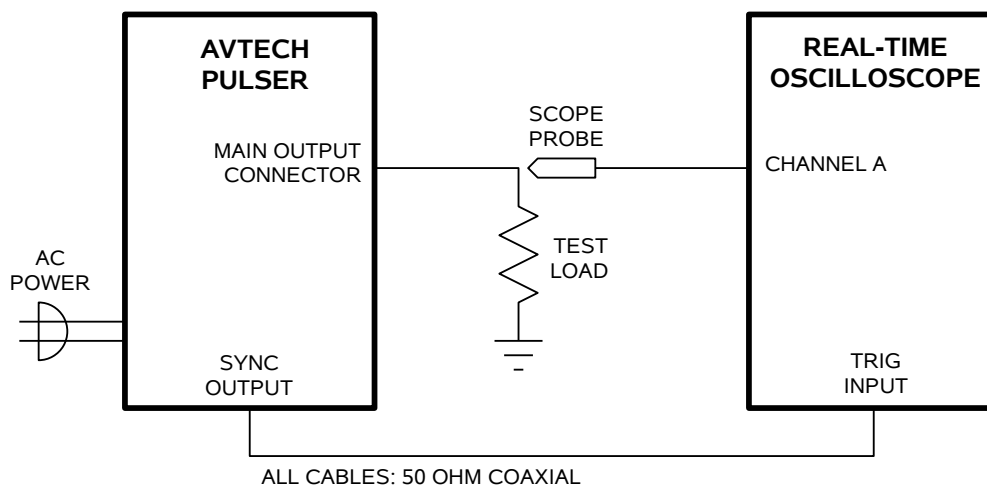

2. Turn on the AVO-6HF-B. The main menu will appear on the LCD.
3. To set the AVO-6HF-B to trigger from the internal clock at a PRF of 1 kHz:
 - a) The arrow pointer should be pointing at the frequency menu item. If it is not, press the MOVE button until it is.
 - b) Press the CHANGE button. The frequency submenu will appear. Rotate the ADJUST knob until the frequency is set at 1 kHz.
 - c) The arrow pointer should be pointing at the “Internal” choice. If it is not, press MOVE until it is.
 - d) Press CHANGE to return to the main menu.

4. To set the delay to 1 us:

- a) Press the MOVE button until the arrow pointer is pointing at the delay menu item.
- b) Press the CHANGE button. The delay submenu will appear. Rotate the ADJUST knob until the delay is set at 1 us.
- c) The arrow pointer should be pointing at the "Normal" choice. If it is not, press MOVE until it is.
- d) Press CHANGE to return to the main menu.

5. To set the pulse width to 1 us:

- a) Press the MOVE button until the arrow pointer is pointing at the pulse width menu item.
- b) Press the CHANGE button. The pulse width submenu will appear. Rotate the ADJUST knob until the pulse width is set at 1 us.
- c) Press CHANGE to return to the main menu.

6. At this point, nothing should appear on the oscilloscope.

7. To enable the output:

- a) Press the MOVE button until the arrow pointer is pointing at the output menu item.
- b) Press the CHANGE button. The output submenu will appear.
- c) Press MOVE until the arrow pointer is pointing at the "ON" choice.
- d) Press CHANGE to return to the main menu.

8. To change the output amplitude:

- a) Press the MOVE button until the arrow pointer is pointing at the amplitude menu item.
- b) Press the CHANGE button. The amplitude submenu will appear. Rotate the ADJUST knob until the amplitude is set at 250V.
- c) Observe the oscilloscope. You should see 1 us wide, 250V pulses.
- d) Rotate the ADJUST knob. The amplitude as seen on the oscilloscope should vary.
- e) Press CHANGE to return to the main menu.

9. Repeat the last step, but set the amplitude to zero.

10. This completes the first operational check test.

For the second test, the output module is connected.

1. Connect a cable from the SYNC OUT connector to the TRIG input of an oscilloscope. Connect the IN port of the output module to the OUT port on the rear panel of the mainframe using the supplied coaxial cable. Attach the laser diode anode to the output module "OUT" terminal. Connect a Tektronix CT2 or Pearson 2878 current probe (or equivalent) as shown below. Connect the current probe to the oscilloscope. (Some current probes may require a 50 Ohm termination). Set the oscilloscope to trigger externally.

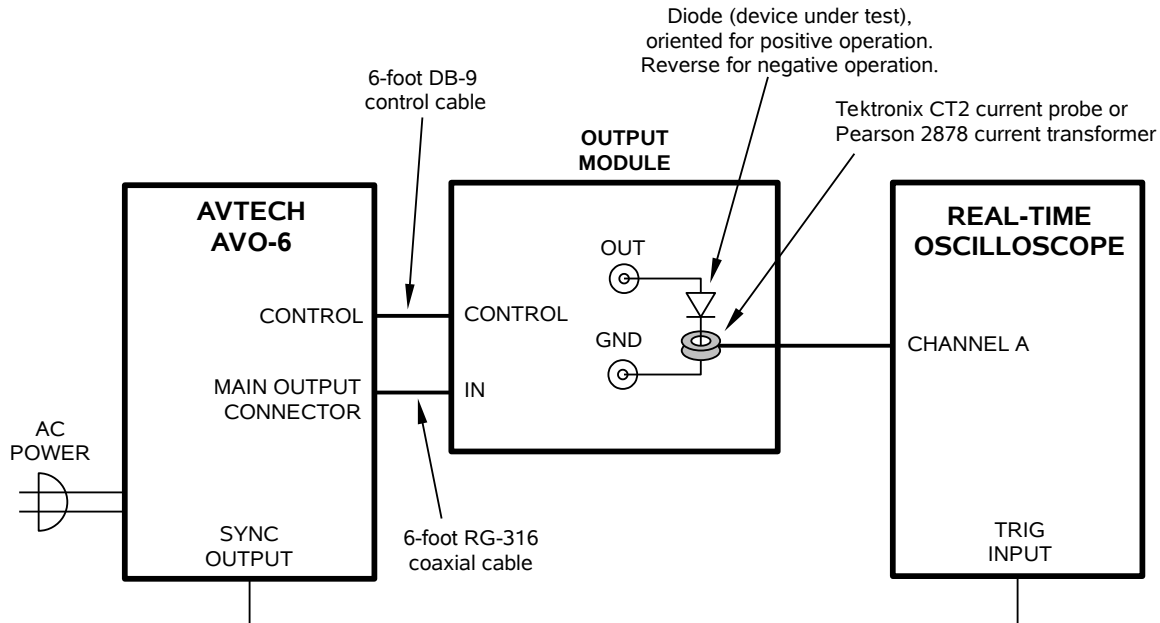

2. Turn on the AVO-6HF-B. The main menu will appear on the LCD.
3. To set the AVO-6HF-B to trigger from the internal clock at a PRF of 1 kHz:
 - a) The arrow pointer should be pointing at the frequency menu item. If it is not, press the MOVE button until it is.
 - b) Press the CHANGE button. The frequency submenu will appear. Rotate the ADJUST knob until the frequency is set at 1 kHz.
 - c) The arrow pointer should be pointing at the "Internal" choice. If it is not, press MOVE until it is.
 - d) Press CHANGE to return to the main menu.
4. To set the delay to 1 ms:
 - a) Press the MOVE button until the arrow pointer is pointing at the delay menu item.
 - b) Press the CHANGE button. The delay submenu will appear. Rotate the ADJUST knob until the delay is set at 1 ms.

c) The arrow pointer should be pointing at the “Normal” choice. If it is not, press MOVE until it is.

d) Press CHANGE to return to the main menu.

5. To set the pulse width to 1 ms:

a) Press the MOVE button until the arrow pointer is pointing at the pulse width menu item.

b) Press the CHANGE button. The pulse width submenu will appear. Rotate the ADJUST knob until the pulse width is set at 1 ms.

c) Press CHANGE to return to the main menu.

6. At this point, nothing should appear on the oscilloscope.

7. To enable the output:

a) Press the MOVE button until the arrow pointer is pointing at the output menu item.

b) Press the CHANGE button. The output submenu will appear.

c) Press MOVE until the arrow pointer is pointing at the “ON” choice.

d) Press CHANGE to return to the main menu.

8. To change the output amplitude:

a) Press the MOVE button until the arrow pointer is pointing at the amplitude menu item.

b) Press the CHANGE button. The amplitude submenu will appear. Rotate the ADJUST knob until the amplitude is set at 250V.

c) Observe the oscilloscope. You should see 1 μ s wide pulses. The voltage across the current probe (Tektronix CT2 or Pearson 2878) should correspond to a measurement of 5 A of current. (A series-connected current-sensing resistor may also be used to measure the current, but this method often produces pronounced overshoot on the rising and falling edges. This is a measurement artefact, and is not present on the actual current waveform. This may be confirmed by using a current probe.)

d) Press CHANGE to return to the main menu.

9. Repeat the last step, but set the amplitude to zero.

10. This completes the operational check.

PROGRAMMING YOUR PULSE GENERATOR

KEY PROGRAMMING COMMANDS

The “Programming Manual for -B Instruments” describes in detail how to connect the pulse generator to your computer, and the programming commands themselves. A large number of commands are available; however, normally you will only need a few of these. Here is a basic sample sequence of commands that might be sent to the instrument after power-up:

*rst	(resets the instrument)
trigger:source internal	(selects internal triggering)
frequency 1000 Hz	(sets the frequency to 1000 Hz)
pulse:width 1 us	(sets the pulse width to 1 us)
pulse:delay 2 us	(sets the delay to 2 us)
volt 200	(sets the amplitude to 200 V)
output on	(turns on the output)

For triggering a single event, this sequence would be more appropriate:

*rst	(resets the instrument)
trigger:source hold	(turns off all triggering)
pulse:width 1 us	(sets the pulse width to 1 us)
output on	(turns on the output)
volt 200	(sets the amplitude to 200 V)
trigger:source immediate	(generates a single non-repetitive trigger event)
trigger:source hold	(turns off all triggering)
output off	(turns off the output)

To set the instrument to trigger from an external TTL input:

*rst	(resets the instrument)
trigger:source external	(selects external triggering)
pulse:width 1 us	(sets the pulse width to 1 us)
pulse:delay 2 us	(sets the delay to 2 us)
volt 200	(sets the amplitude to 200 V)
output on	(turns on the output)

These commands will satisfy 90% of your programming needs.

ALL PROGRAMMING COMMANDS

For more advanced programmers, a complete list of the available commands is given below. These commands are described in detail in the “Programming Manual for -B Instruments”. (Note: this manual also includes some commands that are not implemented in this instrument. They can be ignored.)

<u>Keyword</u>	<u>Parameter</u>	<u>Notes</u>
OUTPut:		
:[STATe]	<boolean value>	
:PROTection		
:TRIPped?		[query only]
[SOURce]:		
:FREQuency		
[:CW FIXed]	<numeric value>	
[SOURce]:		
:PULSe		
:PERiod	<numeric value>	
:WIDTh	<numeric value>	
:DCYClE	<numeric value>	
:HOLD	WIDTh DCYClE	
:DELay	<numeric value>	
:GATE		
:TYPE	ASYNc SYNc	
:LEVel	HIgh LOw	
[SOURce]:		
:VOLTage		
[:LEVel]		
[:IMMEDIATE]		
[:AMPLitude]	<numeric value> EXTeRnal	
:PROTection		
:TRIPped?		[query only]
STATUS:		
:OPERation		
:[EVENT]?		[query only, always returns "0"]
:CONDition?		[query only, always returns "0"]
:ENABle	<numeric value>	[implemented but not useful]
:QUESTionable		
:[EVENT]?		[query only, always returns "0"]
:CONDition?		[query only, always returns "0"]
:ENABle	<numeric value>	[implemented but not useful]
SYSTEM:		
:COMMunicate		
:GPIB		
:ADDReSS	<numeric value>	
:SERial		
:CONTRol		
:RTS	ON IBFull RFR	
:[RECEive]		
:BAUD	1200 2400 4800 9600 19200 38400 57600 115200	
:ERRor		
:[NEXT]?		[query only]
:COUNT?		[query only]
:VERSion?		[query only]
TRIGger:		

:SOURce	INTernal EXTernal MANual HOLD IMMEDIATE	
*CLS		[no query form]
*ESE	<numeric value>	
*ESR?		[query only]
*IDN?		[query only]
*OPC		
*SAV	0 1 2 3	[no query form]
*RCL	0 1 2 3	[no query form]
*RST		[no query form]
*SRE	<numeric value>	
*STB?		[query only]
*TST?		[query only]
*WAI		[no query form]

MECHANICAL INFORMATION

TOP COVER REMOVAL

If necessary, the interior of the instrument may be accessed by removing the four Phillips screws on the top panel. With the four screws removed, the top cover may be slid back (and off).

Always disconnect the power cord before opening the instrument.

There are no user-adjustable internal circuits. For repairs other than fuse replacement, please contact Avtech (info@avtechpulse.com) to arrange for the instrument to be returned to the factory for repair.



Caution: High voltages are present inside the instrument during normal operation. Do not operate the instrument with the cover removed.

RACK MOUNTING

A rack mounting kit is available. The -R5 rack mount kit may be installed after first removing the one Phillips screw on the side panel adjacent to the front handle.

ELECTROMAGNETIC INTERFERENCE

To prevent electromagnetic interference with other equipment, all used outputs should be connected to shielded 50Ω loads using shielded 50Ω coaxial cables. Unused outputs should be terminated with shielded 50Ω coaxial terminators or with shielded coaxial dust caps, to prevent unintentional electromagnetic radiation. All cords and cables should be less than 3m in length.

MAINTENANCE

REGULAR MAINTENANCE

This instrument does not require any regular maintenance.

On occasion, one or more of the four rear-panel fuses may require replacement. All fuses can be accessed from the rear panel. See the “FUSES” section for details.

CLEANING

If desired, the interior of the instrument may be cleaned using compressed air to dislodge any accumulated dust. (See the “TOP COVER REMOVAL” section for instructions on accessing the interior.) No other cleaning is recommended.

WIRING DIAGRAMS

WIRING OF AC POWER

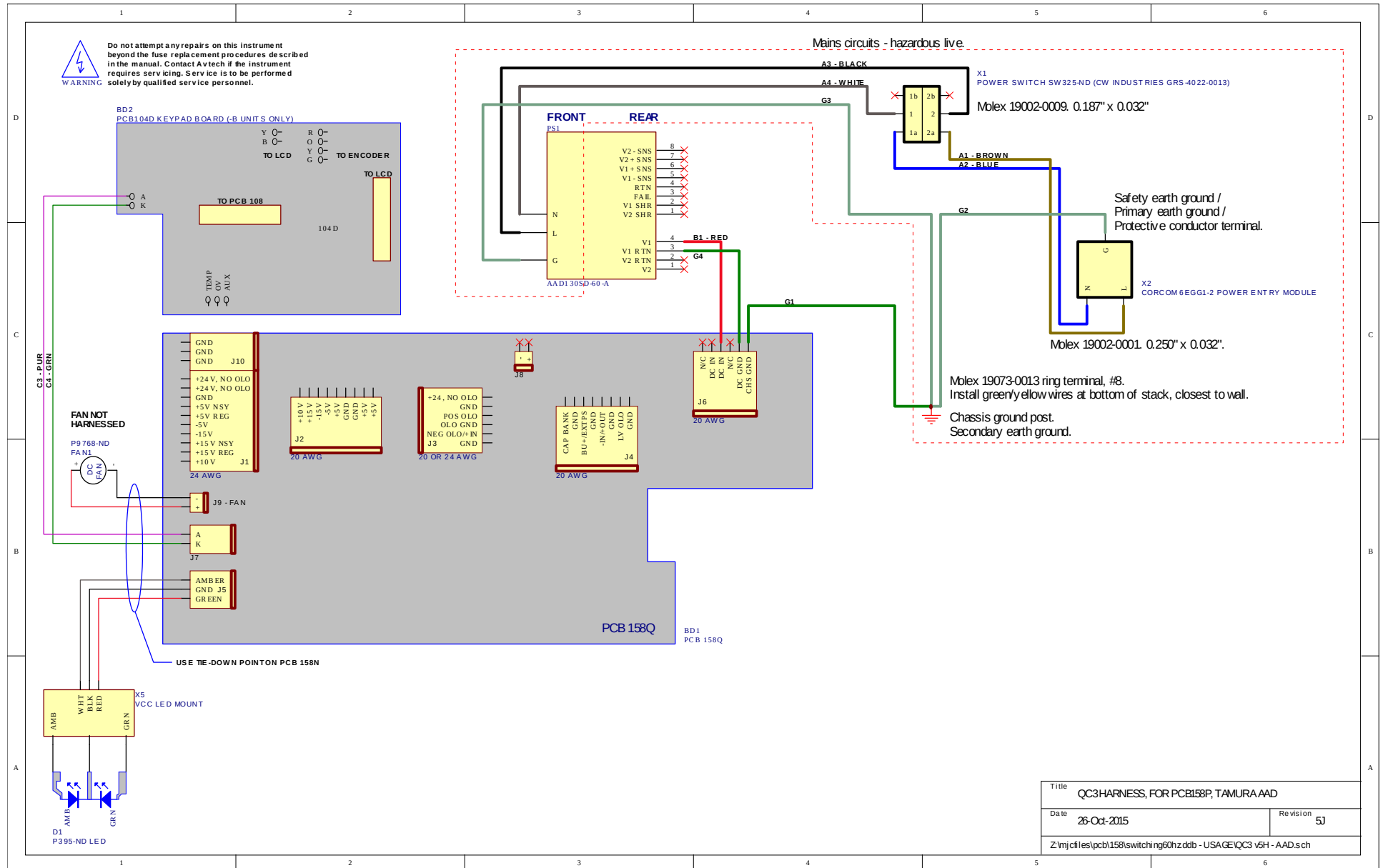

WIRING OF DC POWER

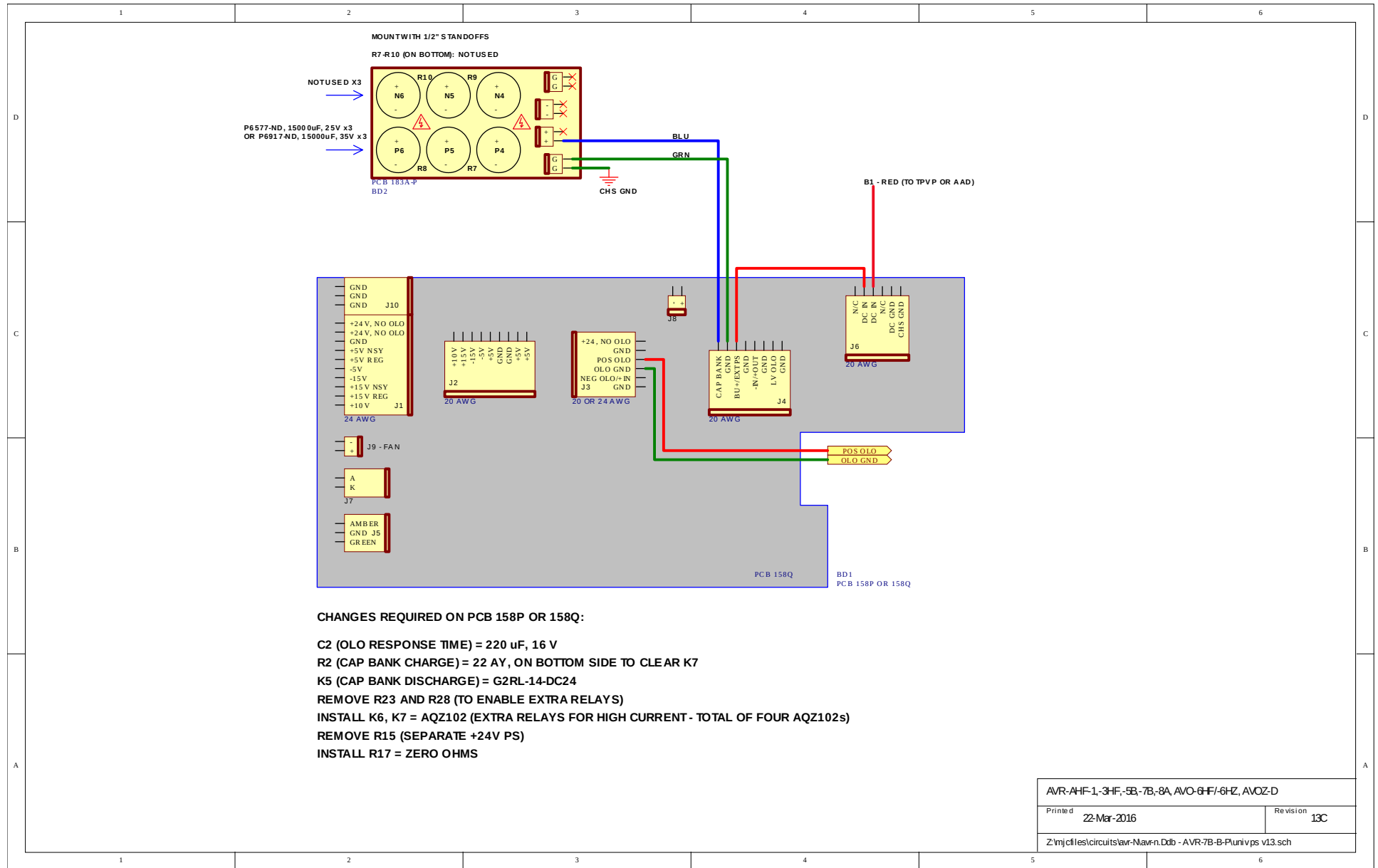

PCB 158Q - LOW VOLTAGE POWER SUPPLY, 1/3

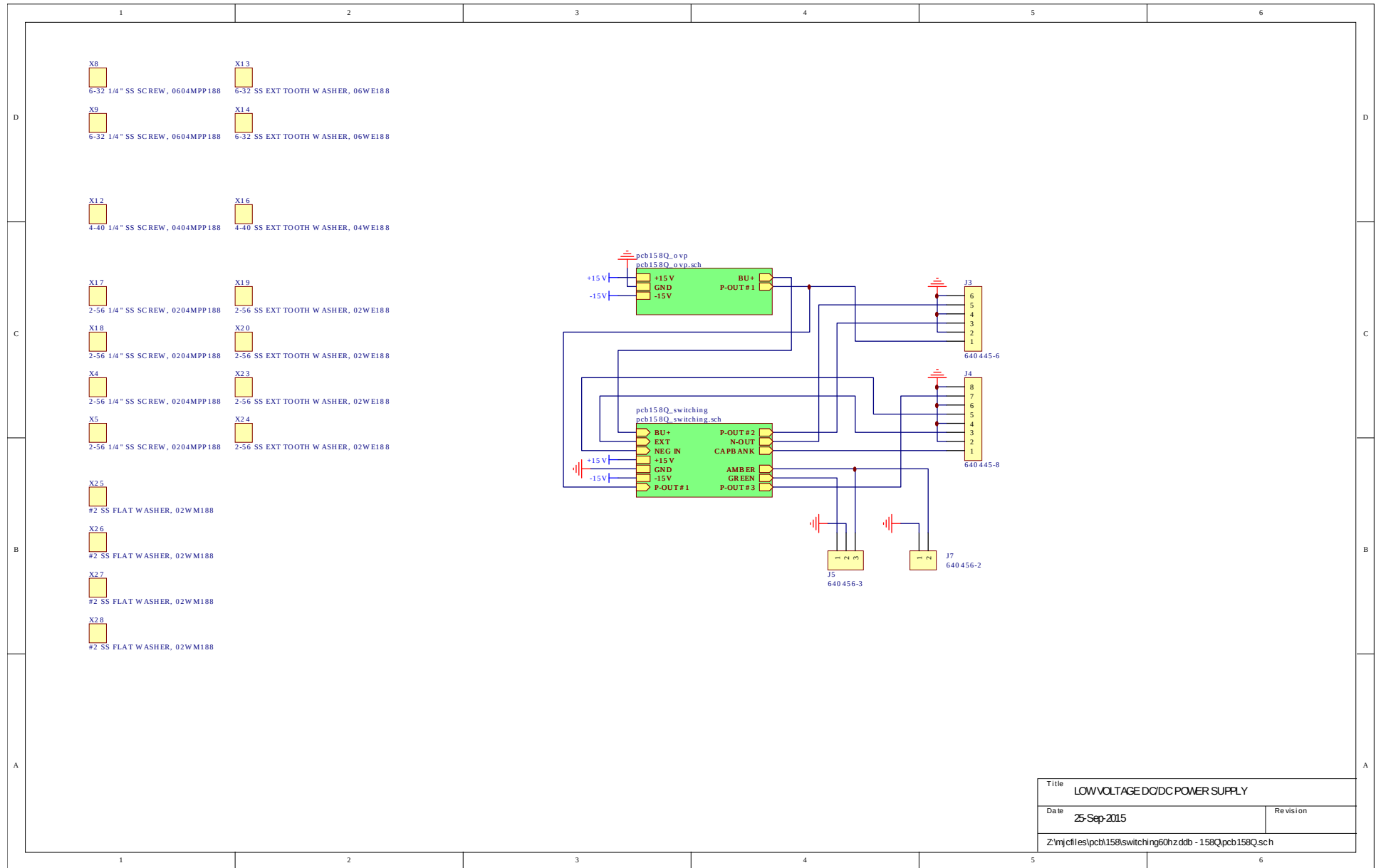

PCB 158Q - LOW VOLTAGE POWER SUPPLY, 2/3

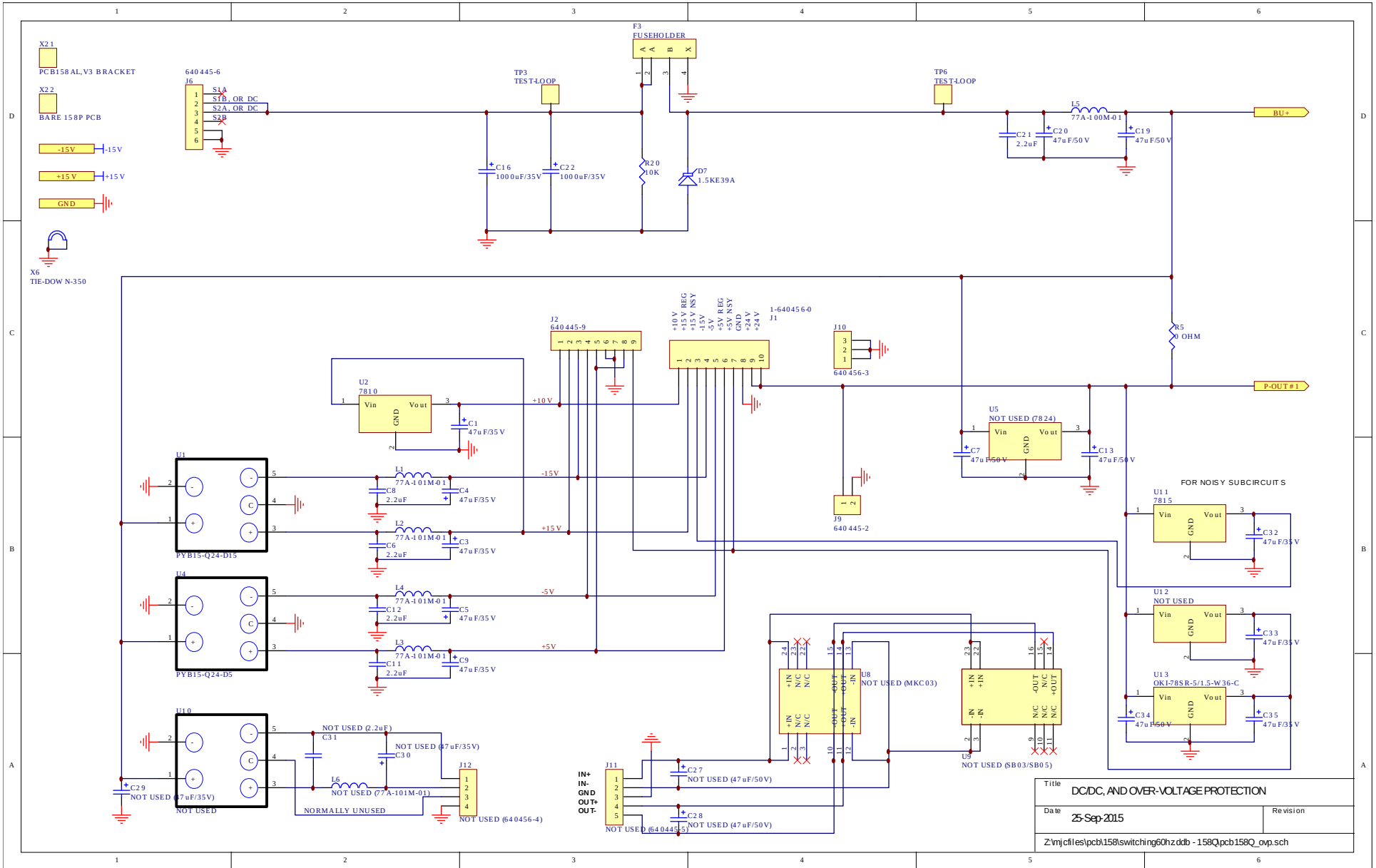

PCB 158Q - LOW VOLTAGE POWER SUPPLY, 3/3

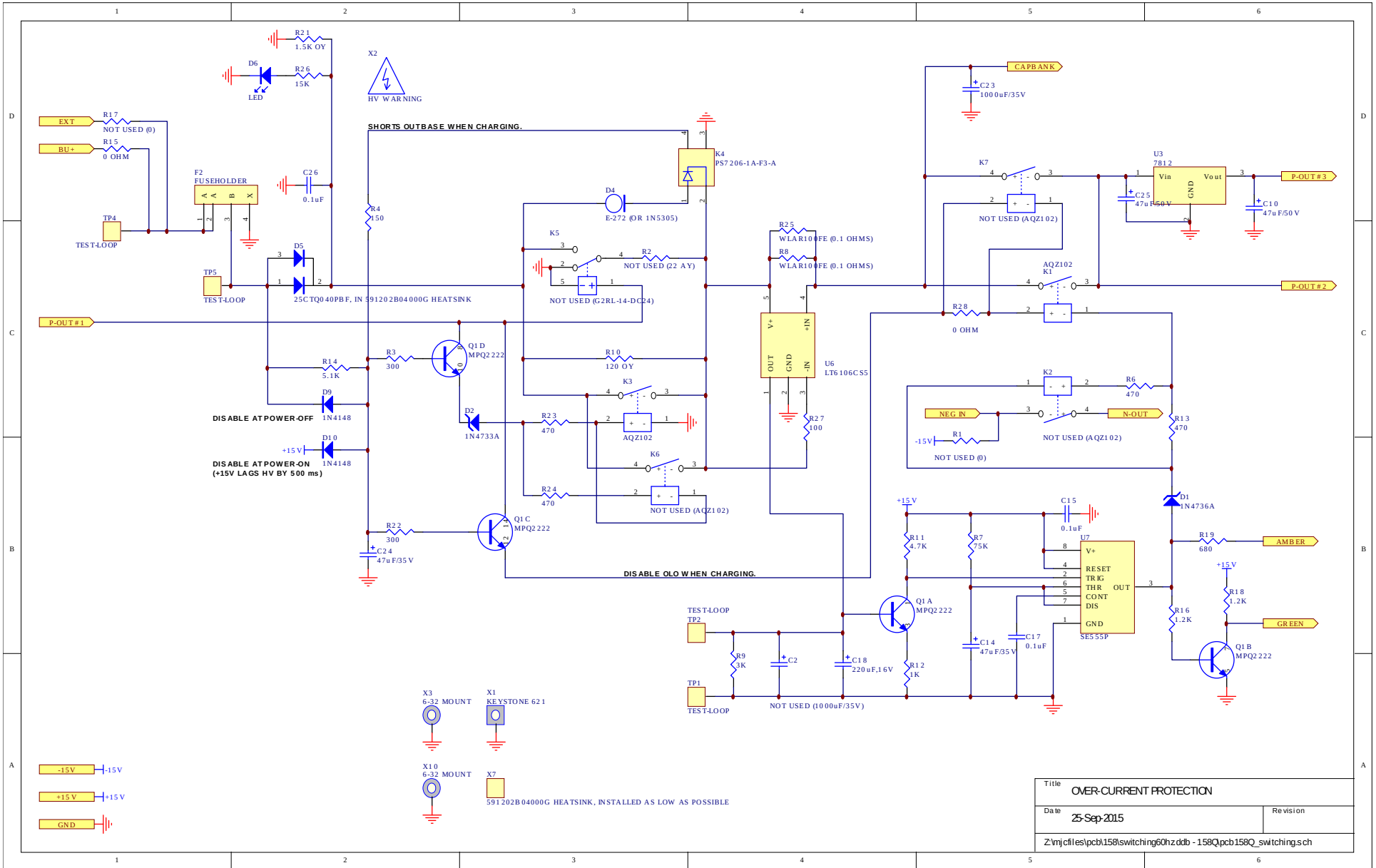

PCB 156D - POLARITY CONTROL PCB (-PN UNITS)

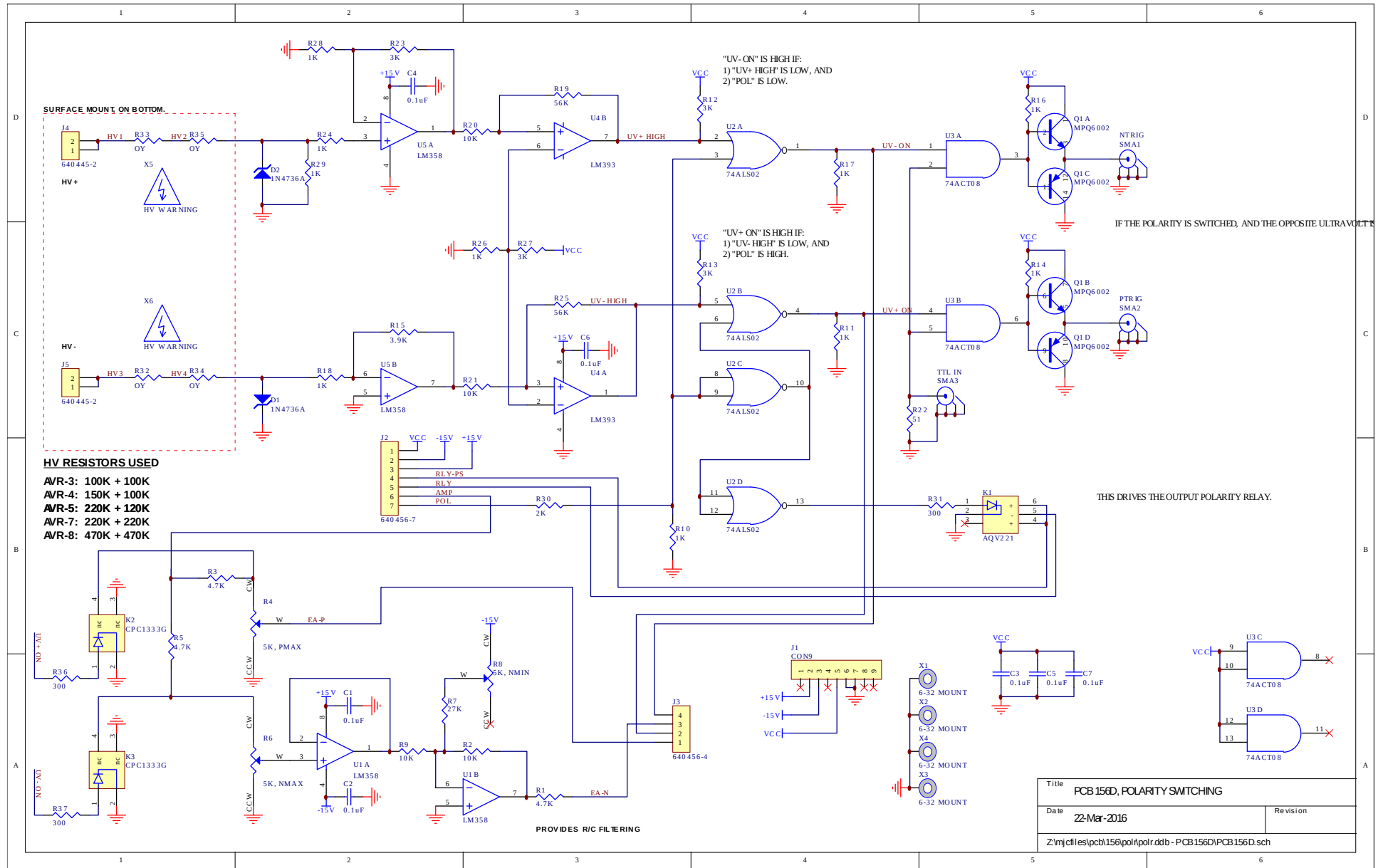

Title		PCB 156D, POLARITY SWITCHING	
Date	22-Mar-2016	Revision	
Z:\nrc\files\pcb\156\pol\pcb.dtb - PCB156D\PCB156D.sch			

PCB 197F - HIGH VOLTAGE DISCHARGE BOARD

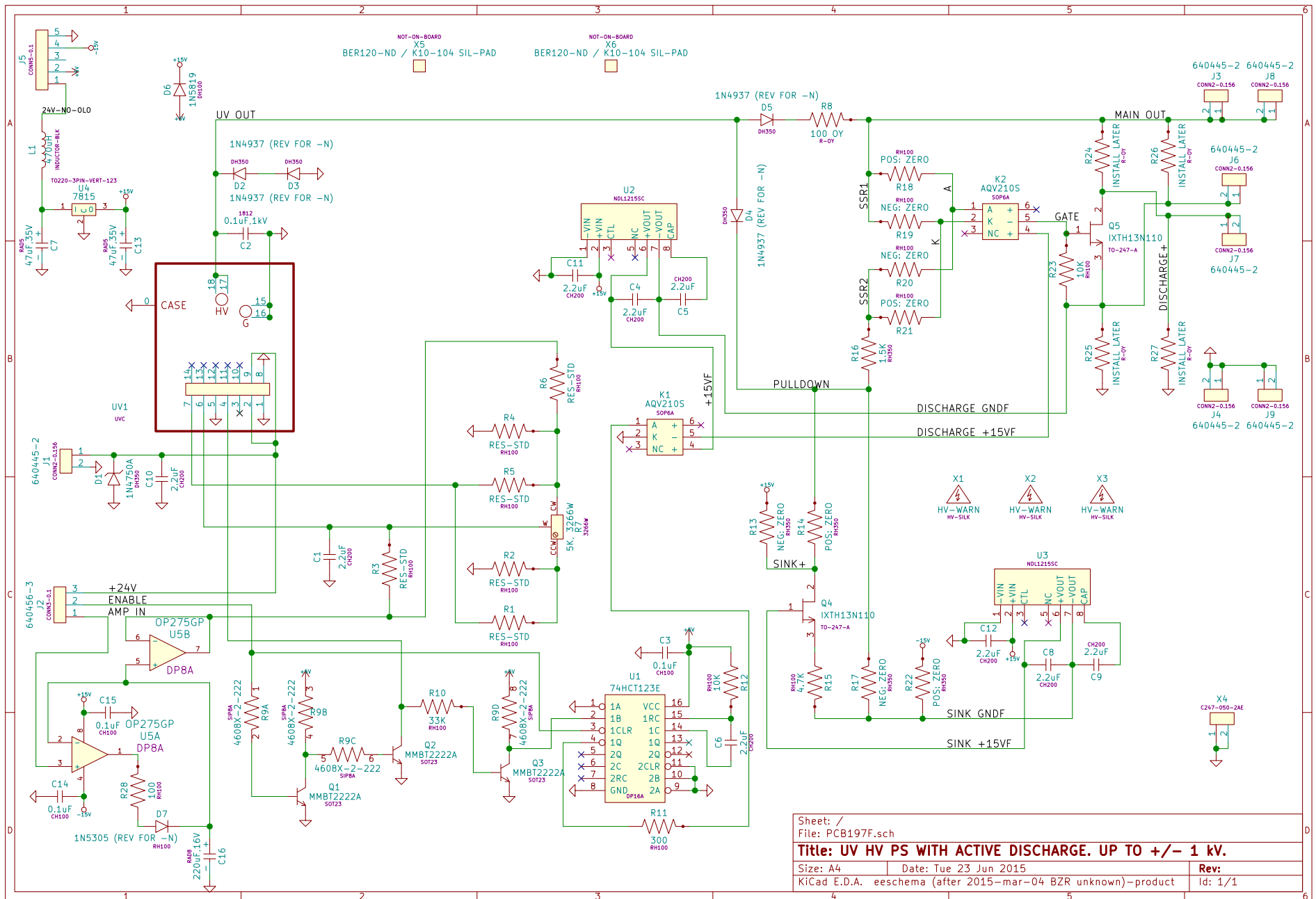

Sheet: /
 File: PCB197F.sch
Title: UV HV PS WITH ACTIVE DISCHARGE. UP TO +/- 1 kV.
 Size: A4 Date: Tue 23 Jun 2015 Rev:
 KiCad E.D.A. eeschema (after 2015-mar-04 BZR unknown)-product Id: 1/1

PCB 183A-S AND 183A-P CAPACITOR BANKS

183A-S (SERIES CAPACITOR BANK)

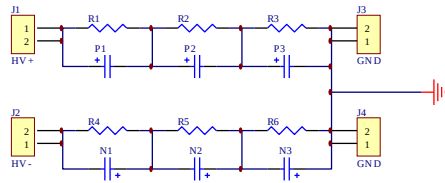

183A-P (PARALLEL CAPACITOR BANK)

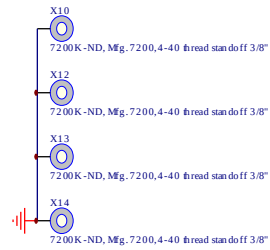
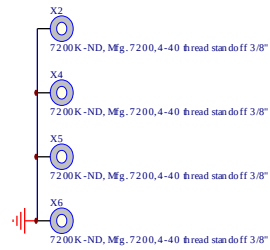
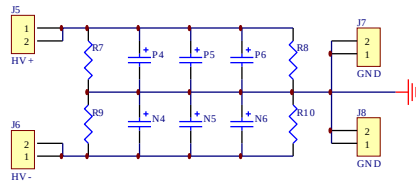

PCB183 CAP BANKS

Printed	19-Aug-2005	Revision	1C
Z:\mjrfiles\pcb183\hv-cap-bank.Ddb - pcb183a.sch			

PCB 94G - ALARM BOARD

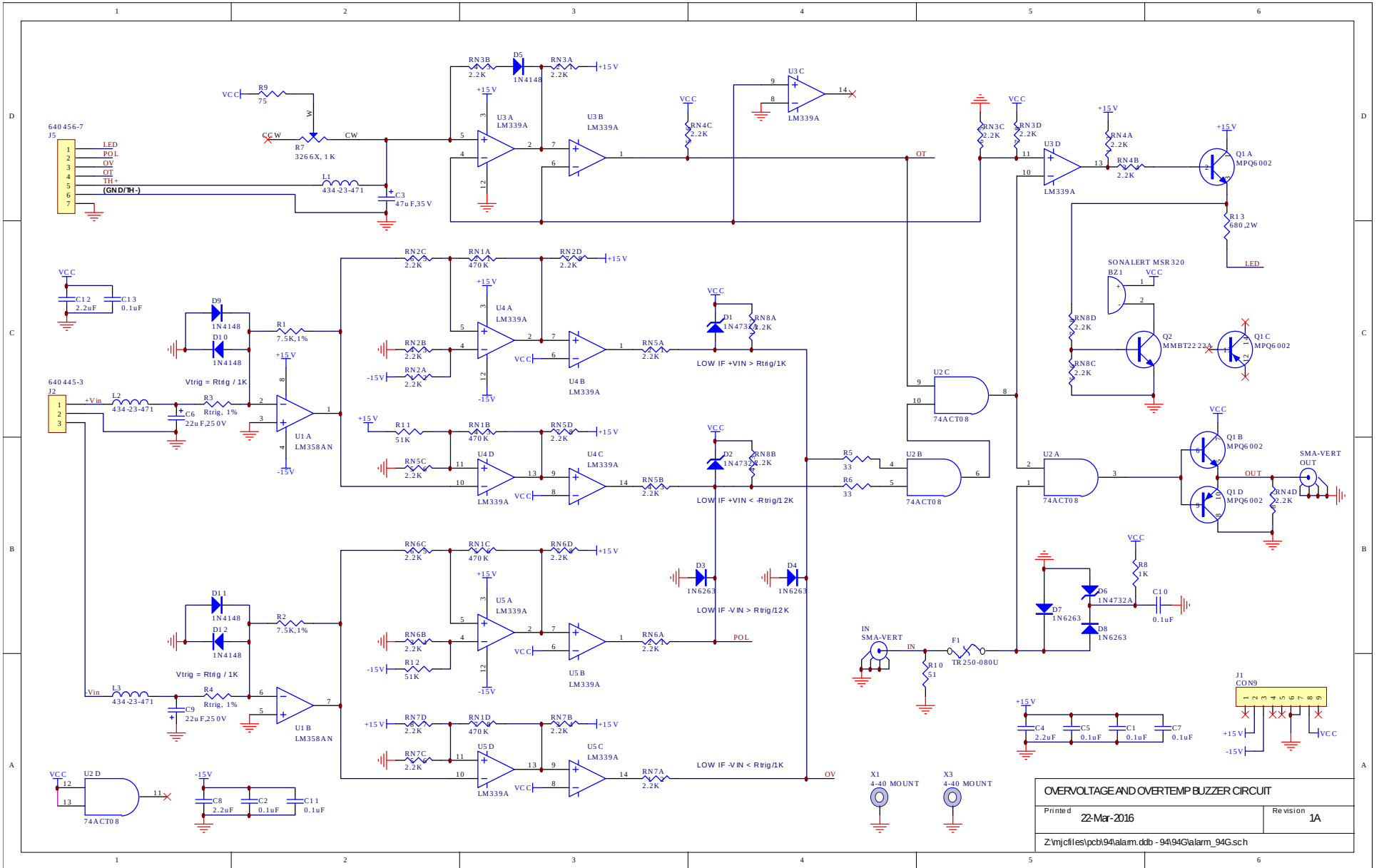

PCB 104F - KEYPAD / DISPLAY BOARD, 1/3

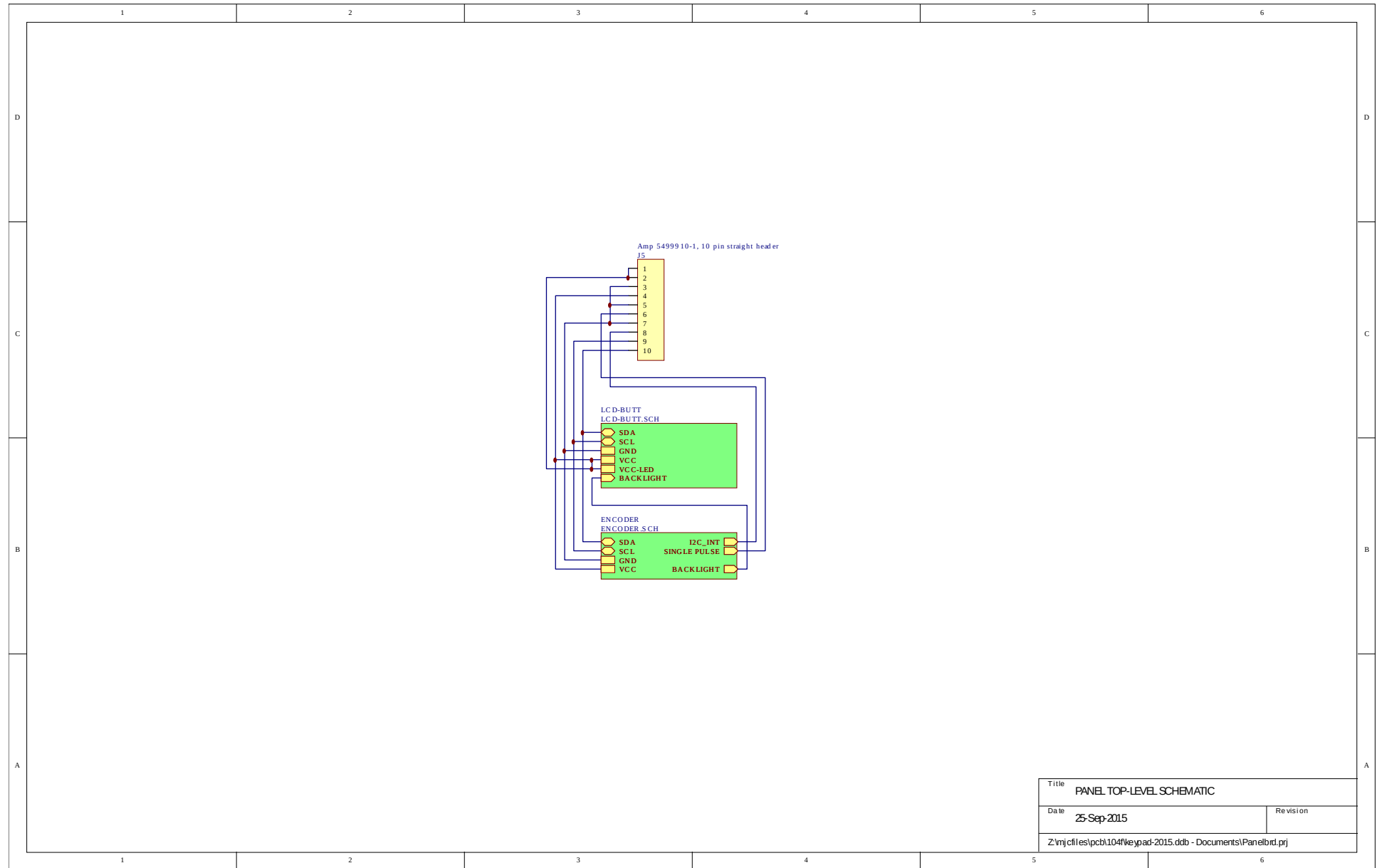

PCB 104F - KEYPAD / DISPLAY BOARD, 2/3

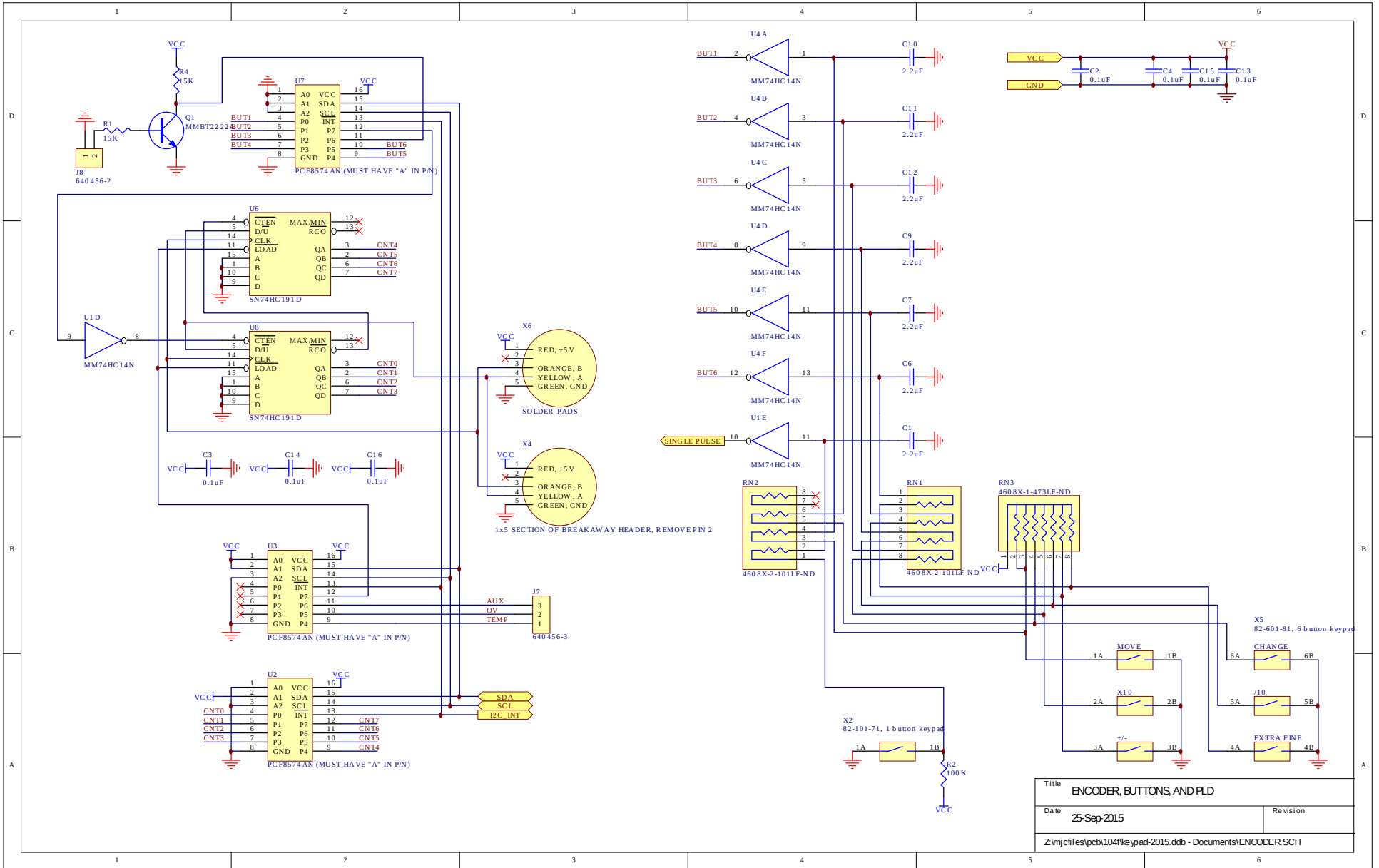

Title		ENCODER, BUTTONS, AND PLD	
Date	25-Sep-2015	Revision	
Z:\njc\files\pcb\104f\keypad-2015.ddb - Documents\ENCODER.SCH			

PCB 104F - KEYPAD / DISPLAY BOARD, 3/3

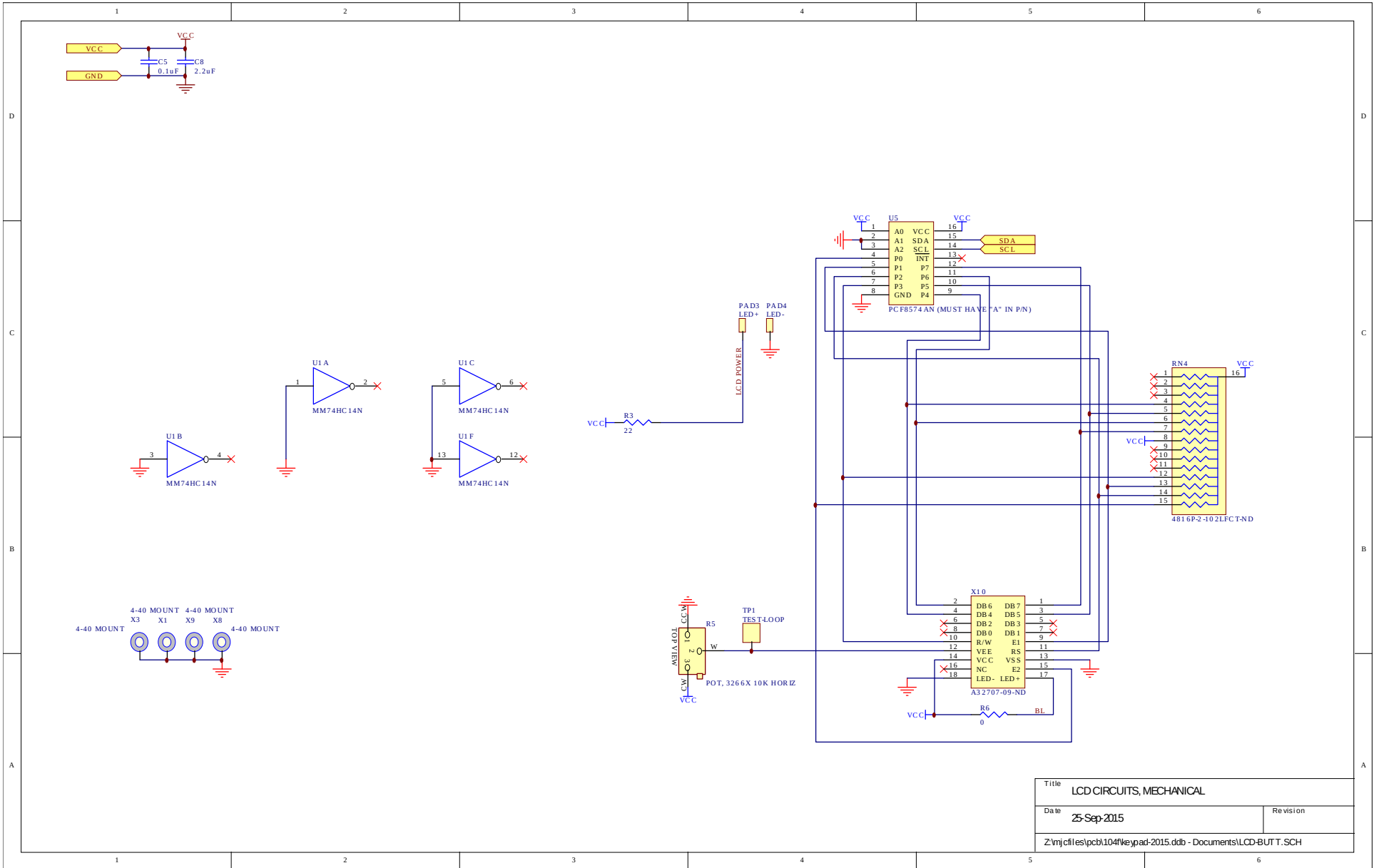

Title		LCD CIRCUITS, MECHANICAL
Date	25-Sep-2015	Revision
Z:\njcf\es\pcb\104f\keypad-2015.ddb - Documents\LCD-BUT.T.SCH		

MAIN WIRING, POSITIVE-POLARITY (-P) UNITS

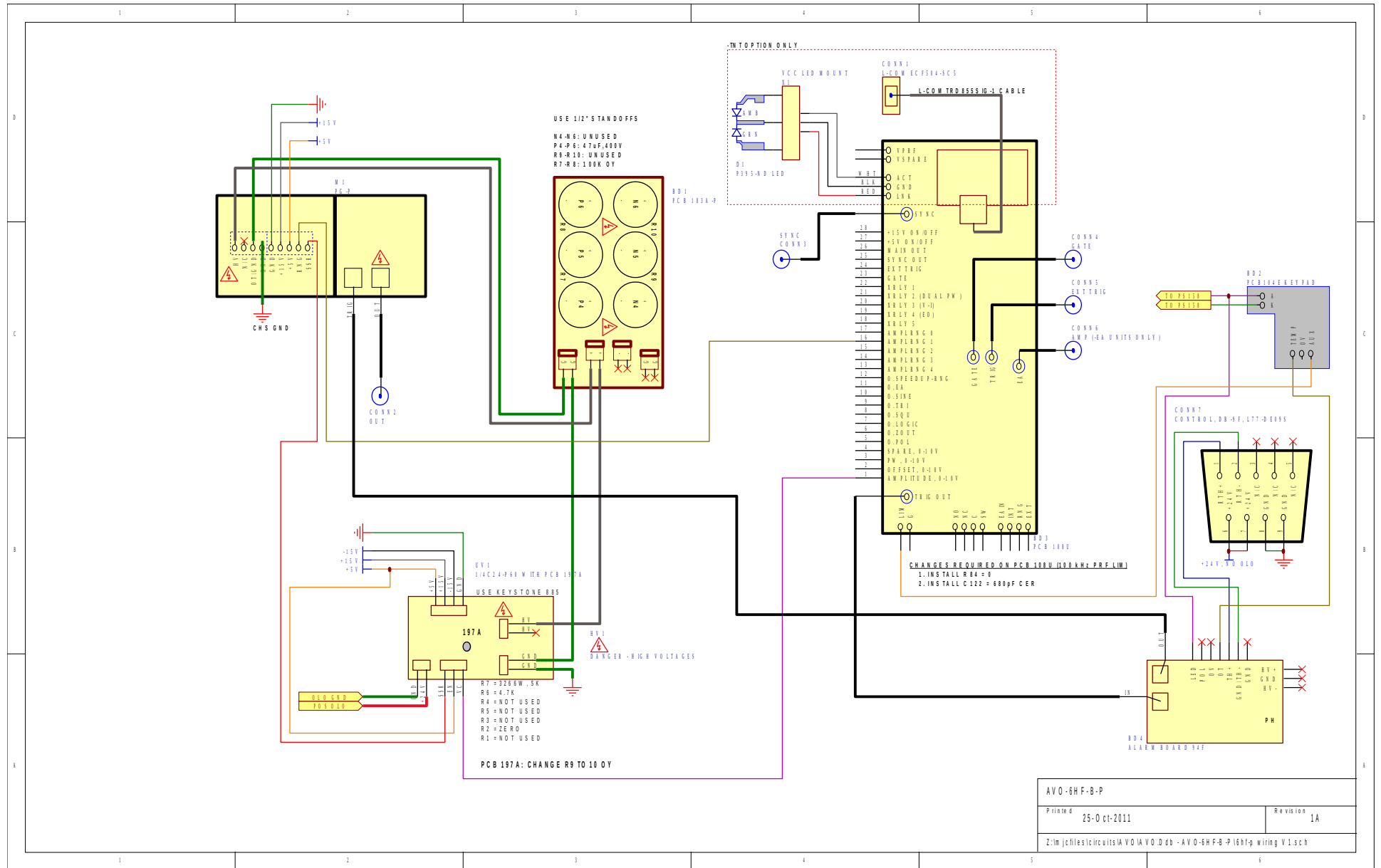

MAIN WIRING, NEGATIVE-POLARITY (-N) UNITS

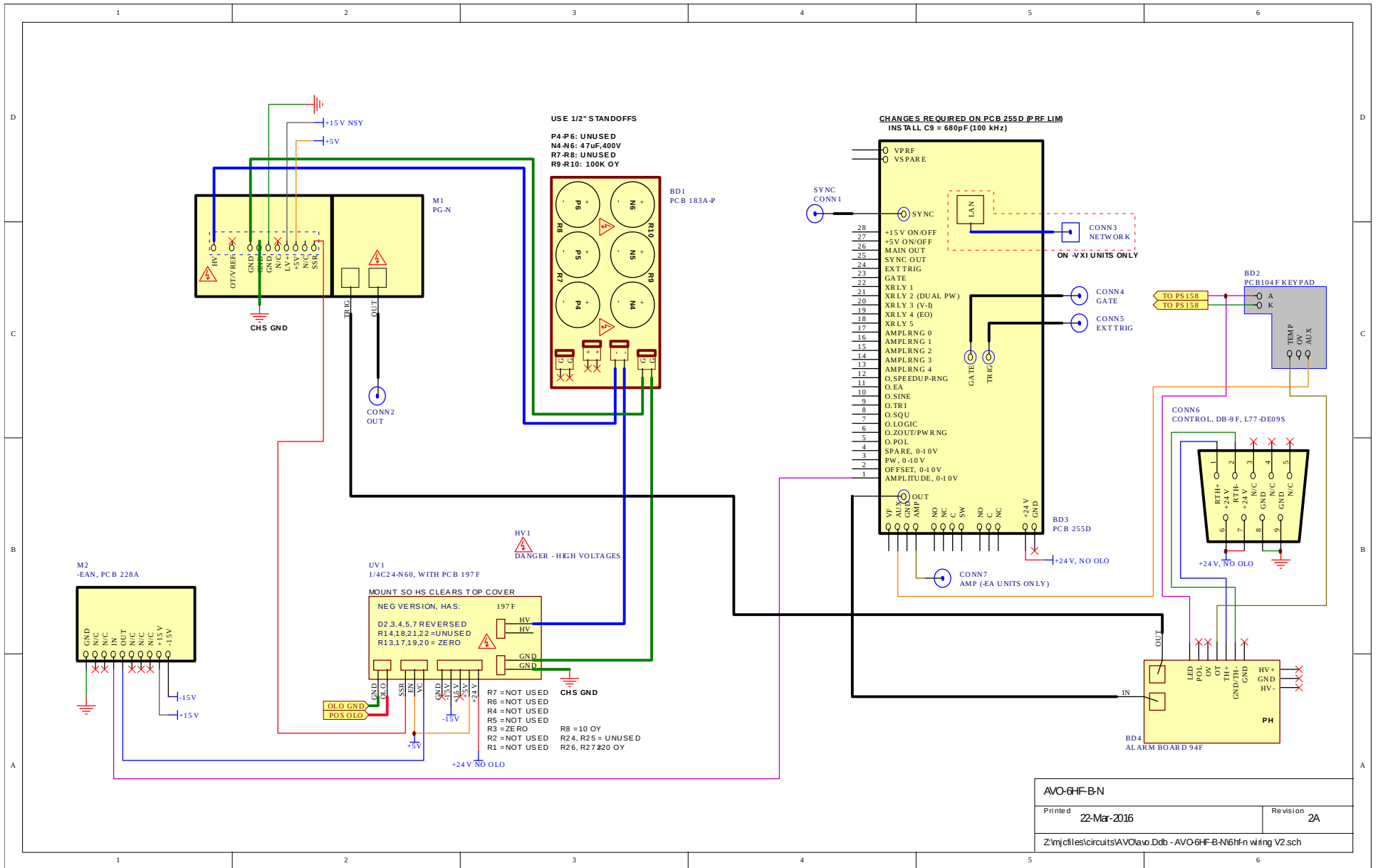

MAIN WIRING, DUAL-POLARITY (-PN) UNITS

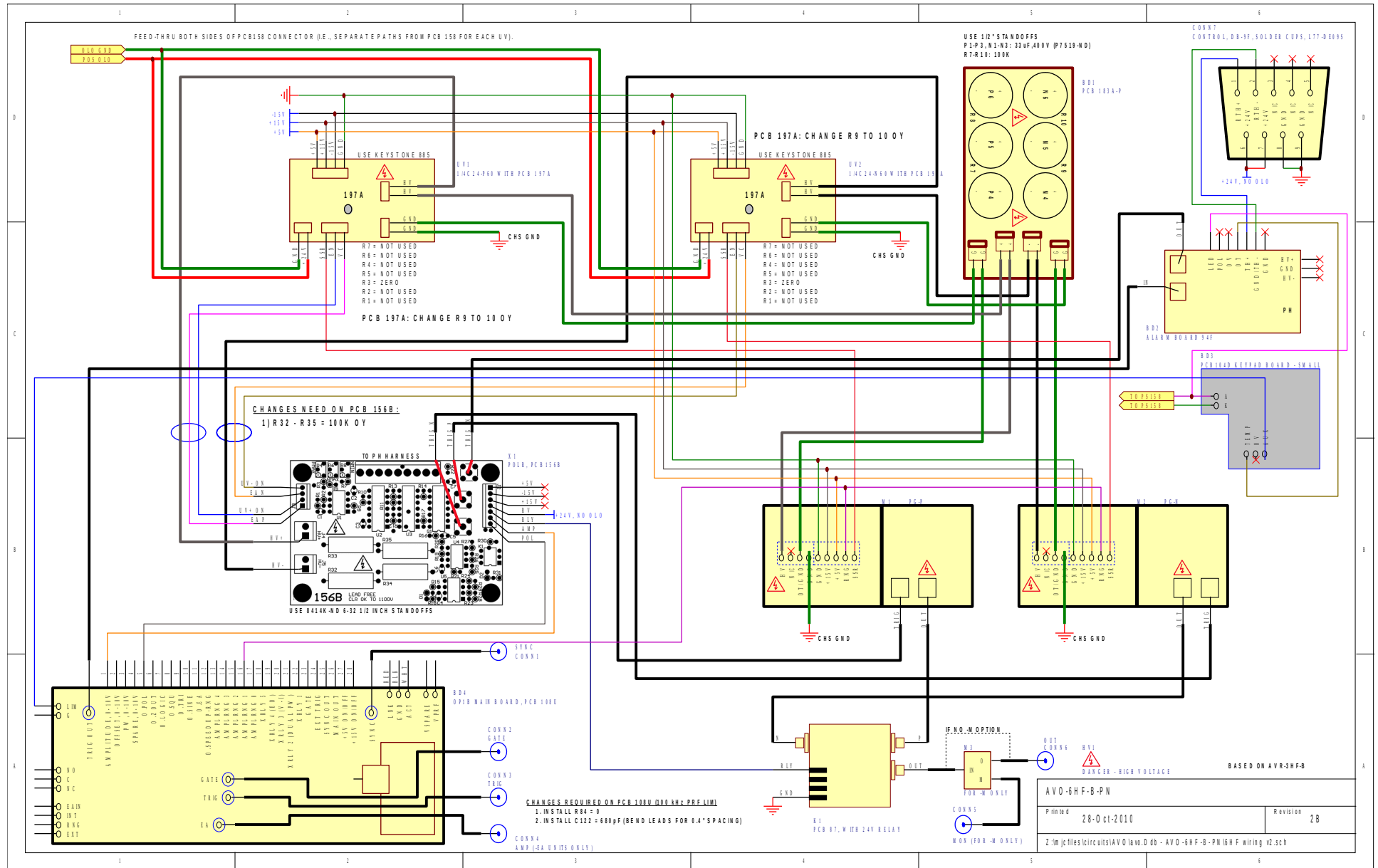

PERFORMANCE CHECK SHEET