

INSTRUCTIONS

MODEL AVO-8C-C-DECB PULSE GENERATOR

S.N.:

WARRANTY

Avtech Electrosystems Ltd. warrants products of its manufacture to be free from defects in material and workmanship under conditions of normal use. If, within one year after delivery to the original owner, and after prepaid return by the original owner, this Avtech product is found to be defective, Avtech shall at its option repair or replace said defective item. This warranty does not apply to units which have been disassembled, modified or subjected to conditions exceeding the applicable specifications or ratings. This warranty is the extent of the obligation assumed by Avtech with respect to this product and no other warranty or guarantee is either expressed or implied.

TECHNICAL SUPPORT

Phone: 613-226-5772 or 1-800-265-6681

Fax: 613-226-2802 or 1-800-561-1970

E-mail: info@avtechpulse.com

World Wide Web: <http://www.avtechpulse.com>

TABLE OF CONTENTS

WARRANTY.....	2
TABLE OF CONTENTS.....	4
FIG. 1: PULSE GENERATOR TEST ARRANGEMENT.....	5
GENERAL OPERATING INSTRUCTIONS.....	6
Fig. 2: FRONT PANEL CONTROLS.....	10
FRONT PANEL CONTROLS.....	11
FIG 3: BACK PANEL CONTROLS.....	12
BACK PANEL CONTROLS.....	13
START-UP CHECK LIST FOR FIRST TIME USE.....	14
POWER SUPPLY AND FUSE REPLACEMENT.....	16
ORIGINAL QUOTATION.....	18
PERFORMANCE CHECK.....	21

FIG. 1: PULSE GENERATOR TEST ARRANGEMENT

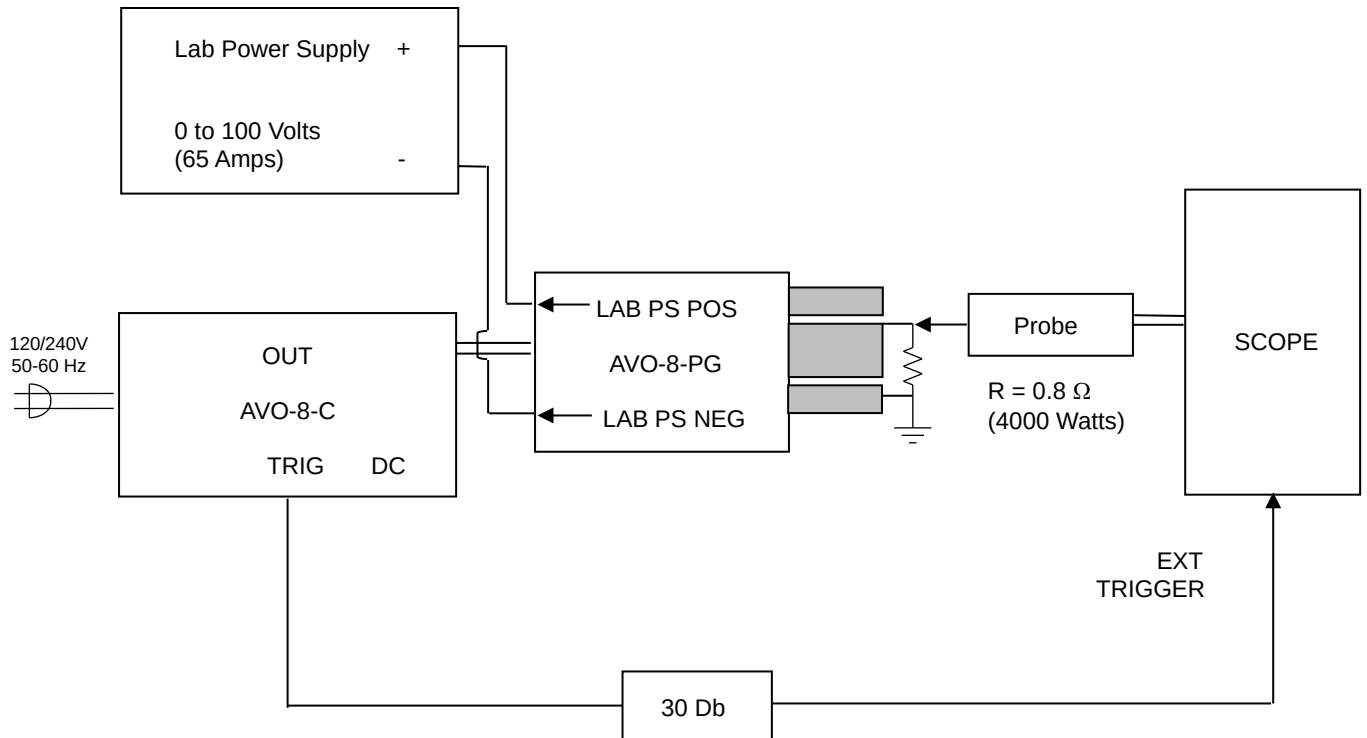

GENERAL OPERATING INSTRUCTIONS

- 1) The equipment should be connected in the general fashion shown above. Since the AVO unit provides an output pulse rise time as low as 0.1 us a fast oscilloscope (at least 50 MHz) should be used to display the waveform.
- 2) The user supplied lab power supply attaches to the -PG output module via the red and black SUPERCON connectors which are supplied. The positive terminal of the power supply is to be connected to the RED SUPERCON connector on the -PG module. The negative terminal on the lab power supply is to be connected to the BLACK SUPERCON connector on the -PG module. For a -P unit, the negative terminal on the lab power supply must be grounded.
- 3) The output module (-PG) must be connected to the mainframe via the RS232 style gray cable (which mates to the OUT connector on the mainframe rear panel).
- 4) WATER COOLING. The output module has provision for water cooling. (Thread size is ¼" NPT). This cooling is necessary when the duty cycle exceeds about 10%. The water requirement is approximately 5 litres/minute. If water cooling is not used, or if the water supply fails, the instrument will heat up until the automatic temperature-protection circuitry trips and disables the output until it has cooled. An audible alarm sounds when the protection circuitry trips.
- 5) The trig output channel provides TTL level signals. To avoid overdriving the TRIG input channel of some scopes, a 30 db attenuator should be placed at the input to the scope trigger channel. The TRIG output precedes the main output when the front panel ADVANCE-DELAY switch is in the ADVANCE position. The TRIG output lags the main output when the switch is in the DELAY position.
- 6) To obtain a stable output display the PW and PRF controls on the front panel should be set mid-range. The front panel INT-EXT-MAN switch should be in the INT position. The DELAY controls and the scope triggering controls are then adjusted to obtain a stable output. The scope may then be used to set the desired PRF by rotating the PRF controls.
- 7) The output terminals of the pulse generator module consists of a short length of microstrip transmission line protruding from the module chassis. The OUT terminal is the center conductor which is bounded on both sides by the ground plane (see below). Note that the "OUT" red banana terminal is in parallel with the microstrip center conductor and so may also be used as the output terminal.

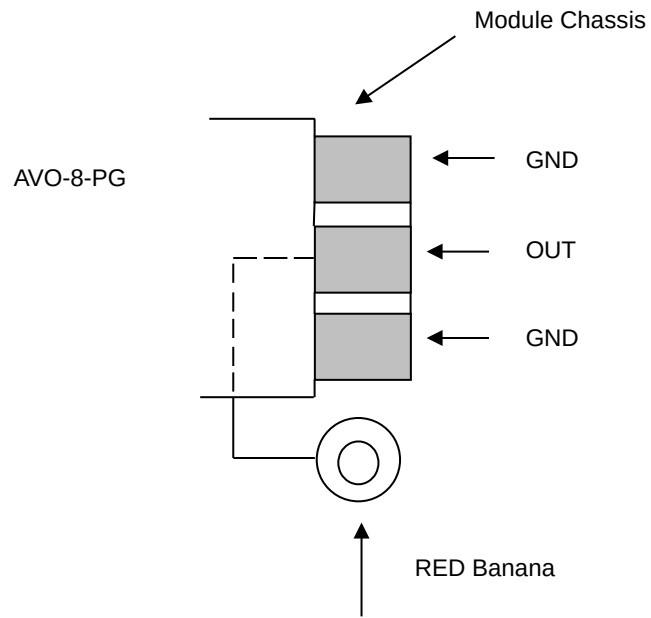

The load should be connected between the OUT and GND terminals using very short leads (≤ 2.0 cm).

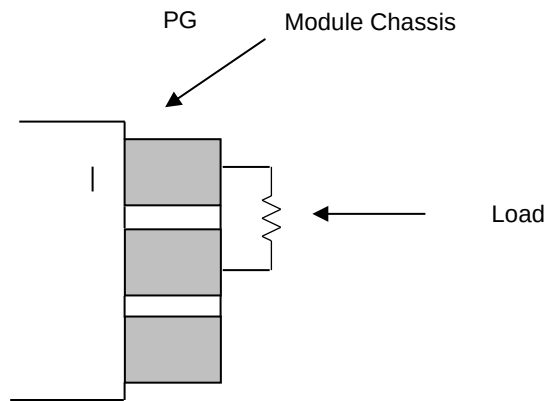

Take care to insure that during soldering the OUT conductor is not shorted to the chassis. Also, use minimal heat when soldering.

- 8) When the PW MODE switch is in the INT position, the output pulse width is controlled by the 2-position range switch and ten-turn fine control.
- 9) The output amplitude is controlled by the amplitude of the DC potential supplied to the SUPERCON connectors on the PG module.
- 10) An external clock may be used to control the output PRF of the unit by setting the front panel INT-EXT-MAN switch in the EXT A position and applying a 50 ns (or wider) TTL level pulse to the TRIG BNC connector input. The external clock may also be used to control the output pulse width by setting the PW mode switch in the EXT B position (in this case, $PW_{OUT} = PW_{IN}$).
- 11) For single pulse operation, set the INT-EXT-MAN switch in the MAN position and push the single pulse button.

- 12) The AVO-8C is designed to supply up to 125 amperes peak to a maximum load voltage of 100 volts. Factory tests are conducted with a 0.5 and 1.0 ohm loads capable of dissipating at least 4000 watts. Higher load resistance values may be used but the input voltage must be limited to 100 volts or less.
- 13) Model AVO-8C will operate with a duty cycle at least as high as 50% when the pulse width is controlled by the front panel Pulse Width and Pulse Width Range controls.
- 14) The unit can be converted from 120 to 240V 50-60 Hz operation by adjusting the voltage selector card in the rear panel fused voltage selector cable connector assembly.
- 15) Model AVO-8C-C includes a high voltage protection circuit which sounds a loud audible alarm if the applied DC voltage exceeds $\approx +105$ VDC. The output stages of the unit will not trigger while the alarm is sounding. The unit also includes a temperature limit circuit which sounds an audible alarm if the temperature of the output stage switching elements exceeds $+35^{\circ}\text{C}$.
- 16) The rear panel monitor output BNC (M) provides an output voltage which is proportional to the current flowing through the banana output terminals.

For a monitor load resistance of 50 Ohms:

$$250\text{mV} \approx 100 \text{ Amps}$$

For a monitor load resistance of $\geq 1\text{K}$:

$$500\text{mV} \approx 100 \text{ Amps}$$

Note that the monitor function is not connected to the microstrip output terminals (option).

- 17) If application assistance is required:

Tel: (613) 226-5772
Fax: (613) 226-2802
Email: info@avtechpulse.com

Fig. 2: FRONT PANEL CONTROLS

FRONT PANEL CONTROLS

(1) ON-OFF Switch. Applies basic prime power to all stages.

(2) PRF Control. Varies PRF from 10 Hz to 1 kHz as follows:

Range 1	0.1 Hz to 1 Hz
Range 2	1 Hz to 10 Hz
Range 3	10 Hz to 0.1 kHz
Range 4	0.1 kHz to 1 kHz

(3) DELAY Control. Controls the relative delay between the reference output pulse provided at the TRIG output (4) and the -PG output. This delay is variable as follows:

Range 1	10 us to 100 us
Range 2	100 us to 1000 us

The TRIG output precedes the main output when the ADVANCE-DELAY switch is in the ADVANCE position and lags when the switch is in the DELAY position.

(4) TRIG Output. This output is used to trigger the scope time base. The output is a TTL level 100 ns (approx.) pulse capable of driving a fifty-ohm load.

(5) PW Control. A ten-turn control and two-position range switch which varies the output pulse width as follows (when the PW MODE switch is in the INT mode):

Range 1	10 us to 100 us
Range 2	100 us to 1 ms

6) EXT-INT-MAN Control. With this toggle switch in the INT position, the PRF of the AVO unit is controlled via an internal clock which in turn is controlled by the PRF control. With the toggle switch in the EXT position, the AVO unit requires a 50 ns (or wider) TTL level pulse applied at the TRIG input in order to trigger the output stages. In addition, in this mode, the scope time base must be triggered by the external trigger source. With the MODE switch in the EXT A position the output pulse width is controlled by the PW controls. With the MODE switch in the EXT B position, the output pulse width equals the input trigger pulse width. For single pulse operation, set the INT-EXT-MAN switch in the MAN position.

7) SINGLE PULSE. For single pulse manual operation, set the front panel INT-EXT-MAN switch in the MAN position and push the SINGLE PULSE button.

FIG 3: BACK PANEL CONTROLS

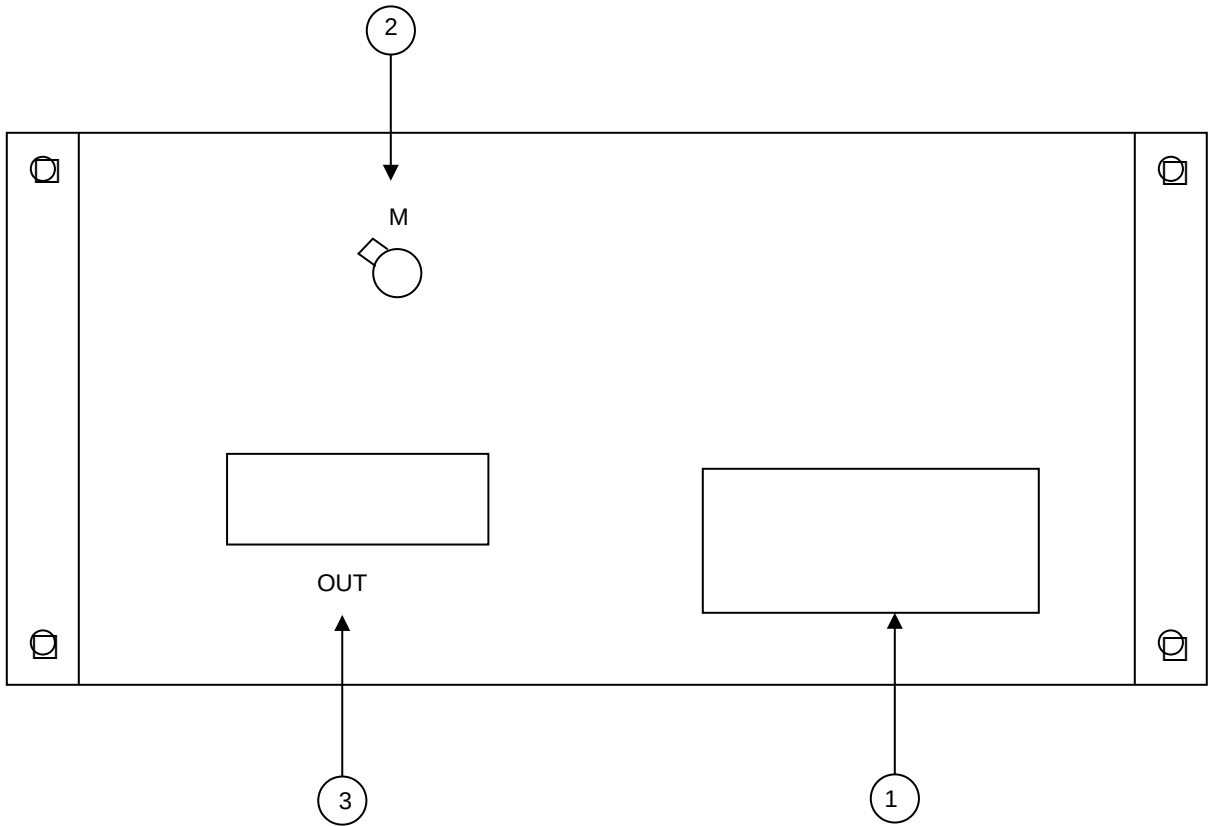

BACK PANEL CONTROLS

- (1) FUSED CONNECTOR, VOLTAGE SELECTOR. The detachable power cord is connected at this point. In addition, the removable cord is adjusted to select the desired input operating voltage. The unit also contains the main power fuse (0.5 A SB).
- (2) The monitor output BNC (M) provides an output voltage which is proportional to the current flowing through the banana output terminals.

For a monitor load resistance of 50 Ohms:

$$250\text{mV} \approx 100 \text{ Amps}$$

For a monitor load resistance of $\geq 1\text{K}$:

$$500\text{mV} \approx 100 \text{ Amps}$$

Note that the monitor function is not connected to the microstrip output terminals (option).

- (3) OUT. The gray RS232 style cable from the output module connects to this connector.

START-UP CHECK LIST FOR FIRST TIME USE

- 1) The instruction manual has been studied thoroughly.
- 2) The -PG module is connected to the mainframe as shown in the "Basic Test Arrangement" section. (The output module should always be connected to the mainframe BEFORE power is applied).
- 3) The load is connected to the banana OUT terminals on the output module. If the load is a diode, the anode of the load is connected to the OUT terminal. Note that with a diode load, a low-inductance current limiting high power resistor must be placed in series with the diode to help limit the peak current. For initial testing, it is recommended that a resistive load be used. Factory tests are conducted using a 1.0 Ohm 4000 Watt resistive load.
- 4) The user-supplied lab power supply is connected with the positive terminal connected to the red SUPERCON on the PG module and the negative terminal connected to the black SUPERCON. The negative terminal is grounded. The power supply potential is set to zero.
- 5) Turn on the prime power to the mainframe.
- 6) Connect the rear panel M output to the scope (1 VOLT/DIV) and connect the TRIG out to the scope time base. The scope time base should be triggering.
- 7) Set the PRF range switch in the 100 Hz position and set the PRF fine control fully clockwise. Set the pulse width range switch in the 100 us position and set the pulse width fine control full clockwise. These PRF and PW settings provide a duty cycle of 1%.
- 8) Connect a scope probe across the resistive test load and apply prime power to the lab power supply (after first insuring that the output amplitude is set to zero).
- 9) Gradually increase the output amplitude on the lab power supply and observe the waveforms on the scope and the DC current level on the DC power supply. A rectangular pulse should appear on the scope (for both the load voltage and monitor channels) and the amplitude should increase as the amplitude control on the mainframe is rotated clockwise. At the same time, the average current supplied by the DC supply will increase. (The rising and falling edges of the monitor waveform may show substantial voltage spikes caused by the inductance of the current sensing element. These spikes are artefacts of the measurement process and are not present in the actual current output waveform). This can be confirmed by using a high speed current transformer such as the Pearson Model 410.

- 10) Observe the pulse width (100 us) and pulse period (10 ms) on the scope and confirm that the peak current does not exceed 100 Amps (i.e. 0.5 Volt out from the monitor output).
- 11) Observe the DC current supplied by the DC supply and ensure that the average current does not exceed 1.0 Amperes.
- 12) Adjust pulse width, pulse period (i.e. PRF) and amplitude to obtain the desired settings. CAUTION: If a duty cycle of 10% is exceeded it will be necessary to use water cooling. Do not exceed 50% duty cycle.
- 13) If additional assistance is required:

Tel: (613) 226-5772

Fax: (613) 226-2802

Email: info@avtechpulse.com

POWER SUPPLY AND FUSE REPLACEMENT

This instrument has three fuses (plus one spare). One, which protects the AC input, is located in the rear-panel power entry module, as described in the “Rear Panel Controls” section of this manual. If the power appears to have failed, check the AC fuse first.

The other two fuses (plus one spare) are located on the internal DC power supply, as shown below:

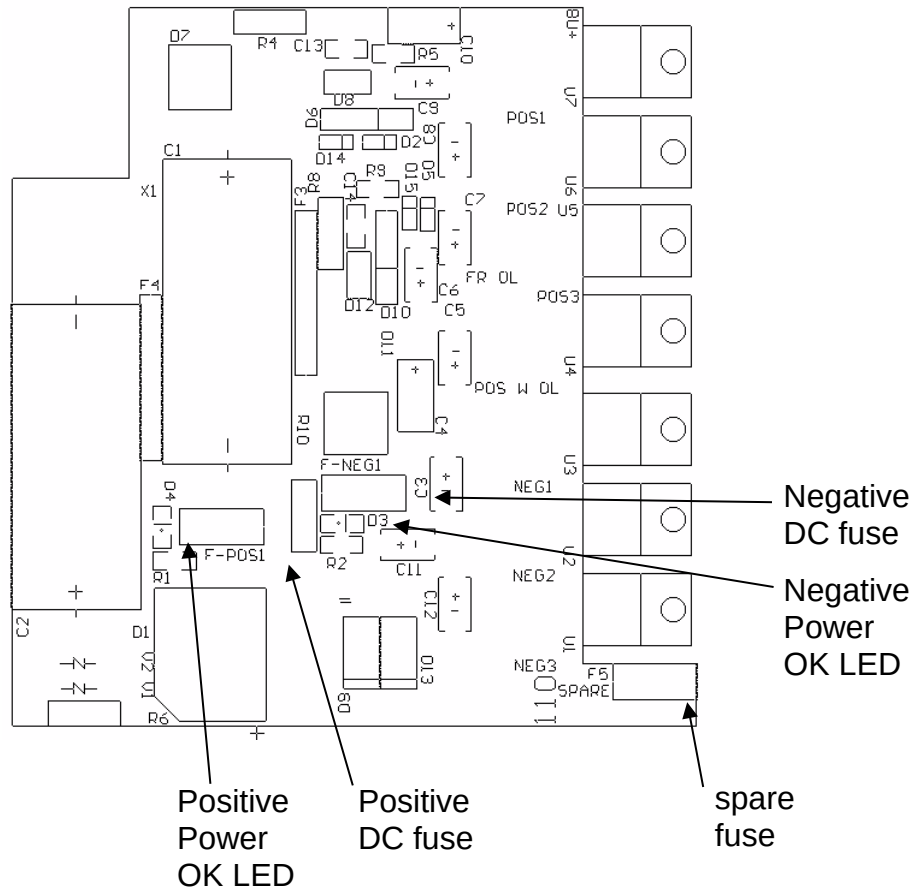

The positive fuse and the spare fuse on this circuit board are 1A slow-blow fuses, Littelfuse part number R452001. (This fuse can be ordered from Digikey, www.digikey.com. The Digikey part number is F1343CT-ND). The negative fuse is a 0.5A slow-blow fuse (Littelfuse R452.500, Digikey part number F1341CT-ND).

If you suspect that the DC fuses are blown, follow this procedure:

1. Remove the top cover, by removing the four Phillips screws on the top cover and then sliding the cover back and off.
2. Locate the two "Power OK" LEDs on the power supply circuit board, as illustrated above.
3. Turn on the instrument.
4. Observe the "Power OK" LEDs. If the fuses are not blown, the two LEDs will be lit (bright red). If one of the LEDs is not lit, the fuse next to it has blown.
5. Turn off the instrument.
6. If a fuse is blown, use needle-nose pliers to remove the blown fuse from its surface-mount holder.
7. Replace the fuse.

ORIGINAL QUOTATION

PERFORMANCE CHECK