

INSTRUCTIONS

MODEL AVO-8D-B-P-NASA1

0 TO 48 V, 250 AMP
LASER DIODE DRIVER
WITH IEEE 488.2 AND RS-232 CONTROL

SERIAL NUMBER: _____

WARRANTY

Avtech Electrosystems Ltd. warrants products of its manufacture to be free from defects in material and workmanship under conditions of normal use. If, within one year after delivery to the original owner, and after prepaid return by the original owner, this Avtech product is found to be defective, Avtech shall at its option repair or replace said defective item. This warranty does not apply to units which have been disassembled, modified or subjected to conditions exceeding the applicable specifications or ratings. This warranty is the extent of the obligation assumed by Avtech with respect to this product and no other warranty or guarantee is either expressed or implied.

TECHNICAL SUPPORT

Phone: 613-226-5772 or 1-800-265-6681

Fax: 613-226-2802 or 1-800-561-1970

E-mail: info@avtechpulse.com

World Wide Web: <http://www.avtechpulse.com>

TABLE OF CONTENTS

WARRANTY	2
TECHNICAL SUPPORT	2
TABLE OF CONTENTS	3
INTRODUCTION	4
SPECIFICATIONS	6
ORIGINAL QUOTATION	7
INSTALLATION	9
VISUAL CHECK	9
PLUGGING IN THE INSTRUMENT	9
FRONT PANEL CONTROLS	10
REAR PANEL CONTROLS	12
GENERAL INFORMATION	13
BASIC TEST ARRANGEMENT	13
BASIC PULSE CONTROL	14
TRIGGER MODES	14
PULSE WIDTH MODES	15
GATING MODES	15
ALARM CONDITIONS AND AUTOMATIC PROTECTION	15
CURRENT MEASUREMENT	16
CURRENT MONITOR FEATURE	16
WATER COOLING	17
TOP AND BOTTOM COVER REMOVAL	17
RACK MOUNTING	17
START-UP CHECK-LIST FOR LOCAL CONTROL	18
PROGRAMMING YOUR PULSE GENERATOR	2
KEY PROGRAMMING COMMANDS	2
ALL PROGRAMMING COMMANDS	2
PERFORMANCE CHECK SHEET	4
APPENDIX A - LOW-VALUE, LOW-INDUCTANCE, HIGH-POWER RESISTORS	5
MEDIUM-POWER RESISTOR SUPPLIERS	5
HIGH-POWER RESISTOR SUPPLIERS	5

INTRODUCTION

The Model AVO-8D-B-P-NASA1 pulse generator is designed for pulsing laser diode and other low impedance loads with rectangular pulses as high as 250 Amperes (or 48 Volts), pulse widths from 5 us to 1.2 ms, at duty cycles as high as 1.25%. Provision for water-cooling is included for operation at high duty cycles (> 0.2%).

The Model AVO-8D-B-P-NASA1 pulse generator is a voltage pulser. The current amplitude is determined by Ohm's Law. That is, the current is the output voltage divided by the series resistance. (The output module contains an internal 0.05Ω resistor. It may be necessary to add additional resistance externally, as shown below, to limit the output current as desired.)

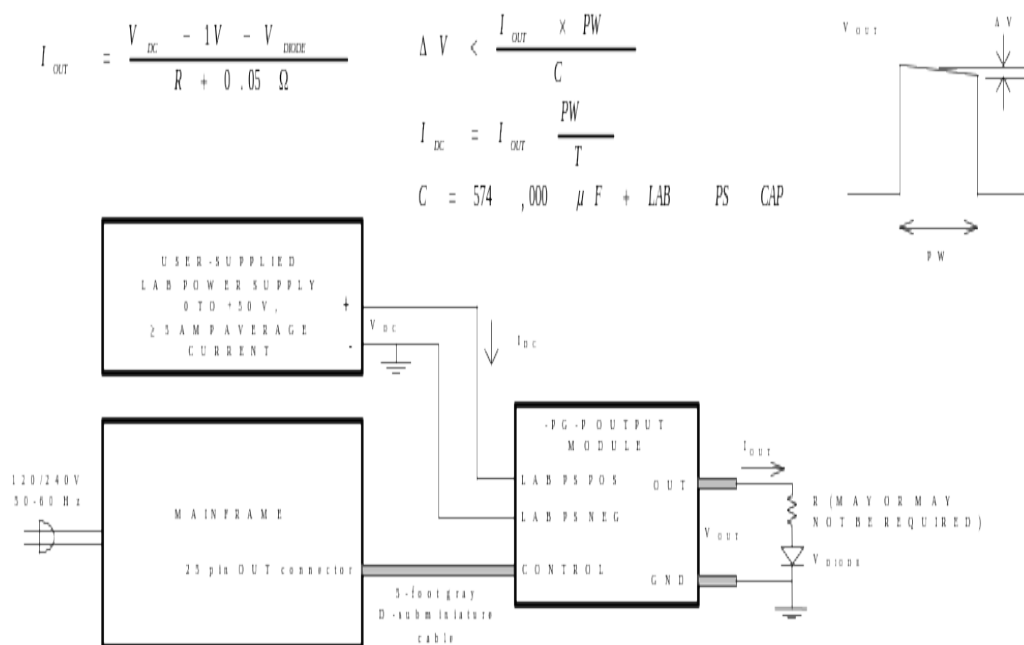

The AVO-8D-B-P-NASA1 system consists of an instrument mainframe, an output module that connects to the mainframe via 5 foot long detachable D-subminiature cables, and a user-supplied high-current DC lab power supply. The load can be connected to the copper bars protruding from the output module. The output terminals of the pulse generator module consist of the 1.5 x 4.0 cm copper bus bars protruding from the end of the -PG modules. The load may be bolted to the output bus bars using 8-32 bolts. Output pulse amplitude control is achieved by means of the user-supplied high current DC lab power supply which provides the prime power to the output module (see diagram below). The output module acts as a high-efficiency, high-speed switch that connects the lab power supply to the load during the output pulse duration. The output pulse voltage amplitude is approximately equal to the lab power supply voltage less about one Volt, less the voltage across the internal resistor ($I_{OUT} \times 0.05\Omega$). The lab power supply must be capable of supplying the average value (i.e. I_{DC}) of the peak current supplied to the load (I_{OUT}). I_{DC} , I_{OUT} , pulse width (PW) and pulse period (T) are related as shown in the diagram. See the "Basic Test Arrangement" section for details.

Protective circuits monitor the lab power supply voltage level and the output module temperature and will automatically disable the triggering of the output stage and sound an audible alarm if either the applied voltage or temperature exceed rated values.

CAUTION

The internal 0.05 Ohm resistor may be damaged if the peak current exceeds 250 Amps, or if the duty cycle exceeds 1.25%. Such failures are not covered by the warranty.

SPECIFICATIONS

Model:	AVO-8D-B-P-NASA1
Amplitude:	0 to +250 Amperes, 0 to +48 Volts
Pulse width:	5 us to 1.2 ms
Rise time:	≤ 2 us
Fall time:	≤ 2 us
PRF:	0 to 10 Hz
Max. duty cycle:	1.25%
Output impedance:	0.05 Ohms
Propagation delay:	≤ 100 ns (Ext trig in to pulse out)
Jitter:	± 500 ps $\pm 0.03\%$ of sync delay (Ext trig in to pulse out)
Trigger required:	Internal Mode: +5 Volt, 50 ns or wider (TTL) External Mode: +5 Volt, $PW_{IN} = PW_{OUT}$ (TTL)
Sync delay:	Sync out to pulse out: Variable 0 to ± 20 ms
Sync output:	+ 3 Volts, 200 ns, will drive 50 Ohm loads
Connectors:	Out: two 0.15 x 2.0 x 4.0 cm copper strips (bolt connection)
Power, DC:	0 to 50 V, 20 Amp maximum average
Power, AC:	120/240 Volts (switchable) 50 - 60 Hz
Dimensions: (H x W x D)	Mainframe: 100 mm x 430 mm x 375 mm (3.9" x 17" x 14.8")
	Output module: 152 mm x 229 mm x 305 mm (6" x 9" x 12")
Chassis material:	anodized aluminum, with blue plastic trim
Mounting:	Any
Temperature range:	+ 10° to + 40° C

ORIGINAL QUOTATION

Quote No:	<u>10135</u>	Sender's Fax:	<u>613-226-2802</u>
File:	<u>/files/officefiles/instructword/avo-8/AVO-8D-B-P-NASA1.ed1.doc</u>	Receiver's Fax:	<u>757-864-8809</u>
To:	<u>NASA Langley Research Center</u>	Receiver's Phone:	<u>757-864-8583</u>
	<u>Hampton, VA</u>	Date:	<u>November 15, 2000</u>
Attn:	<u>Mulugeta Petros</u>	Number of pages:	<u>2, including cover</u>
Subject:	<u>Price and delivery quotation</u>		

I am pleased to offer the following price and delivery quotation:

Quote Number:	10135
Model designation:	AVO-8D-B-P-NASA1
Output Amplitude:	0 to +48 Volts. Output amplitude controlled by a user-supplied 0 to +50 Volts, 20 Amp DC Lab Power Supply.
Output Current:	0 to +250 Amps.
Self-Contained Load Resistor:	0.05 Ohms
Load Connection:	Diode load connects to output module via user-supplied low impedance transmission line. Load current is limited by self-contained 0.05 Ohm load resistor and controlled by varying the DC supply voltage.
Monitor Output:	Included.
Rise, Fall Time:	$\leq 2 \mu\text{s}$
Pulse Width:	5 μs to 1 ms.
PRF:	0 to 10 Hz
Maximum Duty Cycle:	1.25%
Cooling:	Self-contained fan and tap water connection.
GPIB Control:	Yes.
Prime Power a):	120/240 V, 50-60 Hz.
b):	0 to +50 Volts, 20 Amp (or higher) DC lab power supply (with GPIB control).
Other:	See standard AVO-8D-B
Price:	\$9,448.00 US, FOB destination.

Delivery: 60 days, after receipt of order.

Thank you for your interest in our products. Please call or email me if you require any further information.

Regards,

Dr. Walter Chudobiak
Chief Engineer

WC:mf

INSTALLATION

VISUAL CHECK

After unpacking the instrument mainframe and the output module, examine to ensure that they have not been damaged in shipment. Visually inspect all connectors, knobs, liquid crystal displays (LCDs), and the handles. Confirm that a power cord, a GPIB cable, one 25-pin D-subminiature cable, and two instrumentation manuals (this manual and the "OP1B Interface Programming Manual") are with the instrument. If the instrument has been damaged, file a claim immediately with the company that transported the instrument.

PLUGGING IN THE INSTRUMENT

Examine the rear of the instrument. There will be a male power receptacle, a fuse holder and the edge of the power selector card visible. Confirm that the power selector card is in the correct orientation.

For AC line voltages of 110-120V, the power selector card should be installed so that the "120" marking is visible from the rear of the instrument.

For AC line voltages of 220-240V, the power selector card should be installed so that the "240" marking is visible from the rear of the instrument.

If it is not set for the proper voltage, remove the fuse and then grasp the card with a pair of pliers and remove it. Rotate horizontally through 180 degrees. Reinstall the card and the correct fuse.

In the 120V setting, a 1A slow blow fuse is required. In the 240V setting, a 1/2A slow blow fuse is required.

FRONT PANEL CONTROLS

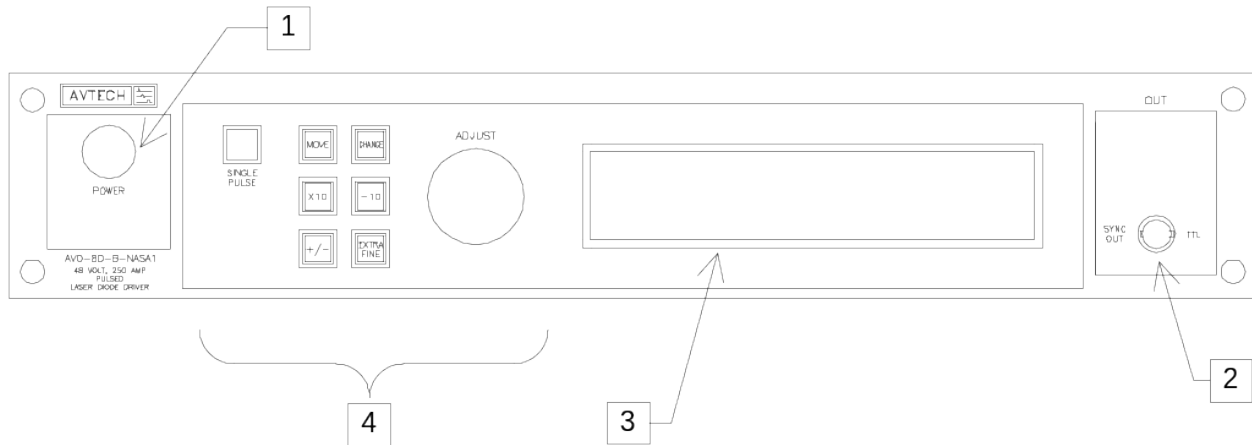

1. POWER Switch. The POWER push button switch applies AC prime power to the primaries of the transformer, turning the instrument on. The push button lamp (#382 type) is connected to the +15V DC supply.
2. SYNC OUT. This connector supplies a SYNC output that can be used to trigger other equipment, particularly oscilloscopes. This signal leads, or lags, the main output by a duration set by the "DELAY" controls and has an approximate amplitude of +3 Volts to $R_L > 1\text{ k}\Omega$ with a pulse width of approximately 200 ns.
3. LIQUID CRYSTAL DISPLAY (LCD). This LCD is used in conjunction with the keypad to change the instrument settings. Normally, the main menu is displayed, which lists the key adjustable parameters and their current values. The "OP1B Interface Programming Manual" describes the menus and submenus in detail.
4. KEYPAD.

Control Name	Function
MOVE	This moves the arrow pointer on the display.
CHANGE	This is used to enter the submenu, or to select the operating mode, pointed to by the arrow pointer.
×10	If one of the adjustable numeric parameters is displayed, this increases the setting by a factor of ten.
+10	If one of the adjustable numeric parameters is displayed, this decreases the setting by a factor of ten.
+/-	If one of the adjustable numeric parameters is displayed, and this parameter can be both positive or negative, this changes the sign of the parameter.
EXTRA FINE	This changes the step size of the ADJUST knob. In the extra-fine mode, the step size is twenty times finer than in the normal mode. This button switches between the two step sizes.
ADJUST	This large knob adjusts the value of any displayed numeric

	<p>adjustable values, such as frequency, pulse width, etc. The adjust step size is set by the "EXTRA FINE" button.</p> <p>When the main menu is displayed, this knob can be used to move the arrow pointer.</p>
--	-----------------------------------------------------------------------------------------------------------------------------------------------------------------------------------------------------------------

REAR PANEL CONTROLS

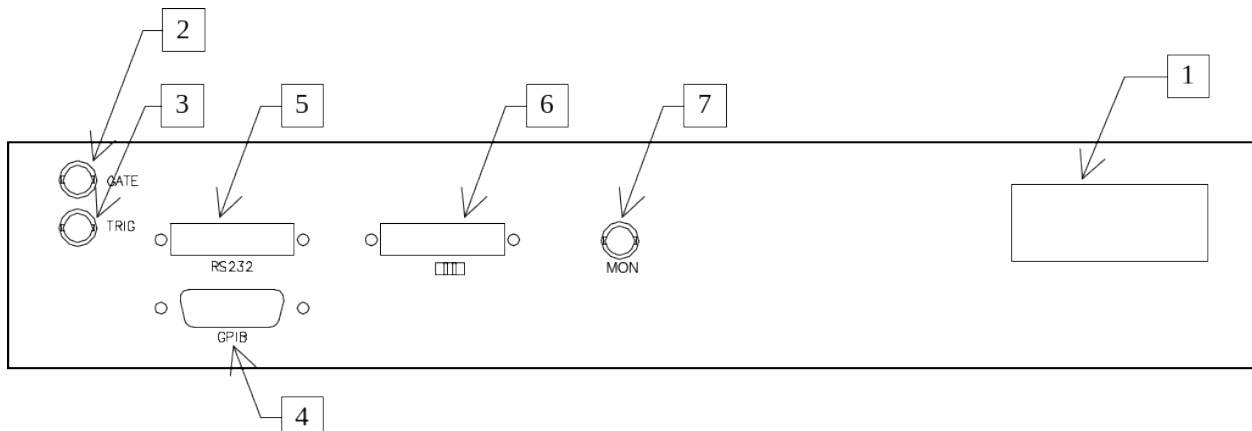

1. **AC POWER INPUT.** A three-pronged recessed male connector is provided on the back panel for AC power connection to the instrument. Also contained in this assembly is a 1A slow blow fuse and a removable card that can be removed and repositioned to switch between 120V AC in and 240V AC in.
2. **GATE.** This TTL-level (0 and +5V) logic input can be used to gate the triggering of the instrument. This input can be either active high or active low, depending on the front panel settings or programming commands. (The instrument triggers normally when this input is unconnected).
3. **TRIG.** This TTL-level (0 and +5V) logic input can be used to trigger the instrument, if the instrument is set to triggering externally. The instrument triggers on the rising edge of this input.
4. **GPIB Connector.** A standard GPIB cable can be attached to this connector to allow the instrument to be computer-controlled. See the “OP1B Interface Programming Manual” for more details on GPIB control.
5. **RS-232 Connector.** A standard serial cable with a 25-pin male connector can be attached to this connector to allow the instrument to be computer-controlled. See the “OP1B Interface Programming Manual” for more details on RS-232 control.
6. **OUT CONNECTOR.** A 5-foot-long, 25-pin D-subminiature cable is used to connect this output connector to the “Control” connector on the output module.
7. **MON CONNECTOR.** This voltage waveform on this current monitor output is proportional to the current waveform on the main output.

GENERAL INFORMATION

BASIC TEST ARRANGEMENT

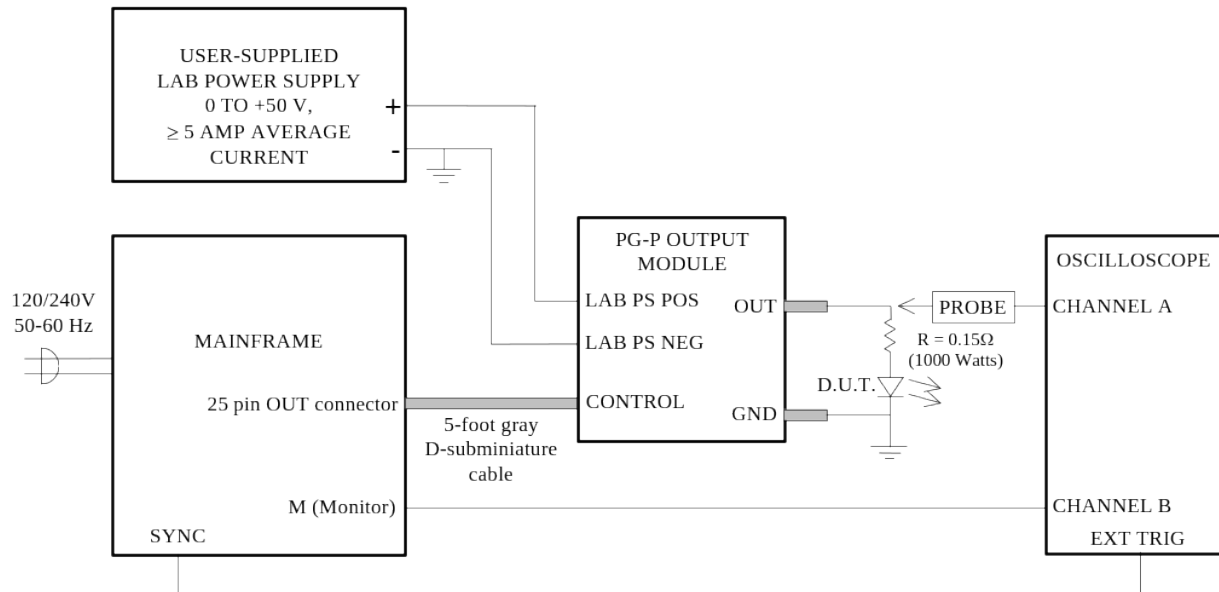

The equipment should be connected in the general fashion shown above. The output modules should always be connected to the mainframe BEFORE power is applied.

The output terminals of the pulse generator module consist of the 1.5 x 4.0 cm copper bus bars protruding from the end of the -PG modules. The load may be bolted to the output bus bars using 8-32 bolts.

This instrument is a voltage pulser, and for this reason a series resistance is required to limit the output current to the desired level. A 0.05 Ohm series resistance is built into the output module. It may be necessary that an additional low-inductance current limiting resistor (see Appendix A for possible suppliers) be placed in series with the laser diode load, particularly if the diode has a low series resistance and "on" voltage (< 25V). This is necessary because the driver is a pulsed voltage source and with a highly nonlinear load such as a laser diode it will be extremely difficult to control and limit the load current without a fixed series resistance. It may be necessary to water-cool the external resistor. The power dissipated in the resistor is given by

$$P = I^2 \times R \times \frac{PW}{T},$$

where "I" is the current, "R" is the resistance, "PW" is the pulse width, and "T" is the pulse period (1/frequency).

CAUTION

The internal 0.05 Ohm resistor may be damaged if the peak current exceeds 250 Amps, or if the duty cycle exceeds 1.25%. Such failures are not covered by the warranty. The peak load current may be monitored by displaying the rear-panel monitor output on an oscilloscope. This output voltage must never exceed 12.5V (which corresponds to 250 Amps of output current).

BASIC PULSE CONTROL

This instrument can be triggered by its own internal clock or by an external TTL trigger signal. In either case, two output channels respond to the trigger: OUT and SYNC. The OUT channel is the signal that is applied to the device under test. Its amplitude and pulse width are variable. The SYNC pulse is a fixed-width TTL-level reference pulse used to trigger oscilloscopes or other measurement systems. When the delay is set to a positive value the SYNC pulse precedes the OUT pulse.

These pulses are illustrated below:

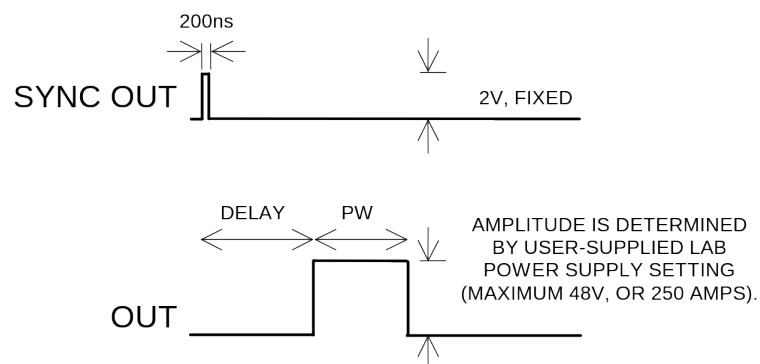

Figure 4 - Basic Output Pulses

The delay, pulse width, and frequency (when in the internal mode), of the OUT pulse can be varied with front panel controls or via the GPIB or RS-232 computer interfaces.

The amplitude of the OUT pulse is controlled by the amplitude of the DC potential supplied to the SUPERCON connectors on the PG module. **CAUTION!! DO NOT EXCEED 50 VDC!**

TRIGGER MODES

This instrument has four trigger modes:

- Internal Trigger: the instrument controls the trigger frequency, and generates the clock internally.

- External Trigger: the instrument is triggered by an external TTL-level clock on the back-panel TRIG connector.
- Manual Trigger: the instrument is triggered by the front-panel “SINGLE PULSE” pushbutton.
- Hold Trigger: the instrument is set to not trigger at all.

These modes can be selected using the front panel trigger menu, or by using the appropriate programming commands. (See the “OP1B Interface Programming Manual” for more details.)

PULSE WIDTH MODES

This instrument has two pulse width modes:

- Normal: the instrument controls the output pulse width.
- $PW_{IN}=PW_{OUT}$: the output pulse width equals the pulse width of the trigger signal on the “TRIG” connector. The instrument must be in the external trigger mode.

These modes can be selected using the front panel pulse width menu, or by using the appropriate programming commands. (See the “OP1B Interface Programming Manual” for more details.)

GATING MODES

Triggering can be suppressed by a TTL-level signal on the rear-panel GATE connector. The instrument can be set to stop triggering when this input high or low, using the front-panel gate menu or the appropriate programming commands. This input can also be set to act synchronously or asynchronously. When set to asynchronous mode, the GATE will disable the output immediately. Output pulses may be truncated. When set to synchronous mode, the output will complete the full pulse width if the output is high, and then stop triggering. No pulses are truncated in this mode.

ALARM CONDITIONS AND AUTOMATIC PROTECTION

To avoid damaging the instrument, observe these rules:

- Never let the lab power supply voltage exceed 50V
- Never let the peak output current exceed 250A

This pulse generator incorporates several features to protect against improper use. A protective circuit controls an internal buzzer. The buzzer will sound if:

- The instrument becomes excessively hot
- The applied DC voltage exceeds 55V
- The applied DC voltage is the incorrect polarity.

In these situations, triggering will be disabled.

CURRENT MEASUREMENT

Measuring current is more difficult than measuring voltage. There are several basic approaches to measuring pulsed current:

1. Use the current monitor. This feature provides a rear-panel BNC output connector, whose voltage waveform is proportional to the current waveform on the main output.
2. If the load is purely resistive, the current may be determined by observing the load voltage with an oscilloscope, and using Ohm's Law:

$$I_{\text{LOAD}} = V_{\text{LOAD}} \div R_{\text{LOAD}}$$

3. If the load is not purely resistive (for instance, a diode load), use a low-resistance, low-inductance, current-sensing resistor connected in series with the load. To minimize inductance, it is usually wise to connect several resistors in parallel. Beware that wirewound resistors usually have far too much inductance to be useful as current-sensing resistors. The current through the load can be determined by measuring the voltage across the sensing resistor, using an oscilloscope.
4. Use a high-performance current transformer, such as the Pearson 101 (see the Pearson web site at www.pearsonelectronics.com). The voltage output of the current transformer (when terminated into a 50 Ohm load) is proportional to the load current.

CURRENT MONITOR FEATURE

As noted in the previous section, a current monitor output is available. The voltage waveform of the monitor output is proportional to the current waveform on the main output:

$$V_{\text{MON}} = I_{\text{LOAD}} \times 0.05 \text{ Volts/Amp}$$

The current monitor circuit also measures the amplitude of the most recent pulse, in amperes, and displays it on the front panel LCD. The value can also be read via the computer interface.

The rising and falling edges of the monitor waveform may show substantial voltages spikes caused by the inductance of the current sensing element. These spikes are artefacts of the measurement process and are not present in the actual current output waveform.

Ensure that the voltage monitor output never exceeds 12.5 Volts, as this corresponds to the maximum peak output current of 250 Amps.

The output module should always be connected to the mainframe BEFORE power is applied. The current monitor will not work properly otherwise.

WATER COOLING

The output module has provision for water-cooling. This cooling is necessary at high duty cycles (i.e. > 0.2%). The water requirement is approximately 5 litres/minute. If water cooling is not used, or if the water supply fails, the instrument will heat up until the automatic temperature-protection circuitry trips and disables the output until it has cooled. The thread size is ¼" NPT.

TOP AND BOTTOM COVER REMOVAL

The top cover of the instrument may be removed by removing the four Phillips screws on the top panel. With these four screws removed, the top panel may be slid off by pulling it towards the rear. The bottom panel may be similarly removed.

RACK MOUNTING

A rack mounting kit is available. The -R5 rack mount kit may be installed after first removing the one Phillips screw on the side panel adjacent to the front handle.

START-UP CHECK-LIST FOR LOCAL CONTROL

- 1) The instruction manual has been studied thoroughly.
- 2) The “Local Control” section of the “OP1B Interface Programming Manual” has been studied thoroughly.
- 3) The -PG module is connected to the mainframe as shown in the “Basic Test Arrangement” section. The 25-pin D-subminiature cable must be connected between the “OUT” connector on the rear-panel of the mainframe and the “Control” connector on the -PG module. (The output module should always be connected to the mainframe BEFORE power is applied.)
- 4) The load is connected to the output module. The output terminals of the pulse generator module consist of the 1.5 x 4.0 cm copper bus bars protruding from the end of the -PG modules. The load may be bolted to the output bus bars using 8-32 bolts. Note that with a diode load, it may be necessary to add a low-inductance current limiting high power resistor in series with the diode to help limit the peak current (a 0.05 Ohm resistance is included in the output module). For initial testing, it is recommended that a resistive load be used. Factory tests are conducted using a 0.15 Ohm 1000 Watt resistive load, which generates a load voltage of 37.5V at 250 Amps.
- 5) The user-supplied lab power supply (which must be capable of generating 0 to +50V, and ≥ 5 Amps of average current) is connected with the SUPERCON connectors (see page 5). The power supply potential is set to zero.
- 6) Connect a water supply hose and a return hose to the two water-cooling connectors. Apply a moderate water flow (approximately 5 litres/minute). The thread size is $\frac{1}{4}$ ” NPT.
- 7) Turn on the prime power to the mainframe. The main menu will appear.
- 8) The arrow pointer should be pointing at the frequency menu item. If it is not, press the MOVE button until it is.
- 9) Press the CHANGE button. The frequency submenu will appear. Rotate the ADJUST knob until the frequency is set at 5 Hz. The arrow pointer should be pointing at the “Internal” choice. If it is not, press MOVE until it is.
- 10) Press CHANGE to return to the main menu.
- 11) Press the MOVE button to move the arrow pointer to the pulse width menu item. Press CHANGE to bring up the pulse width submenu, and rotate the ADJUST knob until the pulse width is set at 500 us. The arrow pointer should be pointing at the “Normal” choice. If it is not, press MOVE until it is. Press CHANGE to return to the main menu.

- 12) Press the MOVE button to move the arrow pointer to the pulse width menu item. Press CHANGE to bring up the pulse width submenu, and rotate the ADJUST knob until the pulse width is set at the desired setting. The arrow pointer should be pointing at the "Normal" choice. If it is not, press MOVE until it is. Press CHANGE to return to the main menu.
- 13) Press the MOVE button to move the arrow pointer is pointing at the output item. Press CHANGE to bring up the output submenu. The arrow pointer should be initially be pointing at the "Output Off" choice. Press MOVE so that the arrow pointer is pointing at the "Output On" choice. (The mainframe is now supplying a trigger to the output module.) Press CHANGE to return to the main menu.
- 14) Connect a scope probe across the resistive test load and apply prime power to the lab power supply (after first ensuring that the output amplitude is set to zero). Connect a second scope probe to the rear-panel monitor output.
- 15) Gradually increase the output amplitude on the lab power supply and observe the load and monitor waveforms on the scope and the DC current level on the DC power supply. A rectangular pulse should appear on the scope (for both the load voltage and monitor channels) and the amplitude should increase as the amplitude control on the mainframe is rotated clockwise. At the same time, the average current supplied by the DC supply will increase.
- 16) Observe the pulse width and pulse period on the scope and confirm that the peak current does not exceed 250 Amps.
- 17) Observe the DC current supplied by the DC supply and ensure that the average current does not exceed 3.2 Amperes.
- 18) Adjust pulse width, pulse period (i.e. PRF) and amplitude to obtain the desired settings.
- 19) If additional assistance is required:

Tel: (613) 226-5772, Fax: (613) 226-2802
Email: info@avtechpulse.com

PROGRAMMING YOUR PULSE GENERATOR

KEY PROGRAMMING COMMANDS

The “OP1B Interface Programming Manual” describes in detail how to connect the pulse generator to your computer, and the programming commands themselves. A large number of commands are available; however, normally you will only need a few of these. Here is a basic sample sequence of commands that might be sent to the instrument after power-up:

```
*rst                (resets the instrument)
trigger:source internal (selects internal triggering)
source:function pulse  (enables pulse mode, rather than DC mode)
frequency 10 Hz       (sets the frequency to 10 Hz)
pulse:width 100 us    (sets the pulse width to 100 us)
pulse:delay 30 us     (sets the delay to 30 us)
output on             (turns on the output)
```

These commands will satisfy 90% of your programming needs.

ALL PROGRAMMING COMMANDS

For more advanced programmers, a complete list of the available commands is given below. These commands are described in detail in the “OP1B Interface Programming Manual”. (Note: this manual also includes some commands that are not implemented in this instrument. They can be ignored.)

<u>Keyword</u>	<u>Parameter</u>	<u>Notes</u>
LOCAL		
OUTPut:		
:[STATe]	<boolean value>	
:PROTection		
:TRIPped?		[query only]
REMOTE		
[SOURce]:		
:FREQuency		
[:CW FIXed]	<numeric value>	
[SOURce]:		
:PULSe		
:PERiod	<numeric value>	
:WIDTh	<numeric value> IN	
:DCYClE	<numeric value>	
:HOLD	WIDTh DCYClE	
:DELay	<numeric value>	
:GATE		
:TYPE	ASYNc SYNc	
:LEVel	HIgh LOw	

STATUS:		
:OPERation		
:[EVENT]?		[query only, always returns "0"]
:CONDition?		[query only, always returns "0"]
:ENABLE	<numeric value>	[implemented but not useful]
:QUESTionable		
:[EVENT]?		[query only, always returns "0"]
:CONDition?		[query only, always returns "0"]
:ENABLE	<numeric value>	[implemented but not useful]
SYSTEM:		
:COMMunicate		
:GPIB		
:ADDRESS	<numeric value>	
:SERial		
:CONTRol		
:RTS	ON IBFull RFR	
:[RECeive]		
:BAUD	1200 2400 4800 9600	
:BITS	7 8	
:ECHO	<boolean value>	
:PARity		
:[TYPE]	EVEN ODD NONE	
:SBITS	1 2	
:ERRor		
:[NEXT]?		[query only]
:COUNT?		[query only]
:VERSion?		[query only]
TRIGger:		
:SOURce	INTernal EXTernal MANual HOLD IMMEDIATE	
*CLS		[no query form]
*ESE	<numeric value>	
*ESR?		[query only]
*IDN?		[query only]
*OPC		
*SAV	0 1 2 3	[no query form]
*RCL	0 1 2 3	[no query form]
*RST		[no query form]
*SRE	<numeric value>	
*STB?		[query only]
*TST?		[query only]
*WAI		[no query form]

PERFORMANCE CHECK SHEET

APPENDIX A - LOW-VALUE, LOW-INDUCTANCE, HIGH-POWER RESISTORS

In general, better results are obtained if a number of medium-power resistors are connected in parallel, instead of using a single high-power resistor.

MEDIUM-POWER RESISTOR SUPPLIERS

- RCD Components
520 East Industrial Park., Manchester, NH USA 03109-5316
Tel: (603) 669-0054 Fax: (603) 669-5455
Internet: <http://www.rcd-comp.com/>
Suggested series: RSF2B
- Ohmite Mfg. Co.
3601 Howard Street
Skokie, IL 60076
Tel: (847) 675-2600
Fax: (847) 675-1505
Internet: <http://www.ohmite.com/>
Suggested series: OY

HIGH-POWER RESISTOR SUPPLIERS

- Isotek Corp.
435 Wilbur Ave., Swansea, MA 02777 USA
Phone: 508-673-2900
Fax: 508-676-0885
Internet: <http://www.isotekcorp.com>
- Vishay Electronic Components (Various subsidiaries)
<http://www.vishay.com/>