



AVTECH ELECTROSYSTEMS LTD.

NANOSECOND WAVEFORM ELECTRONICS  
SINCE 1975

□ P.O. BOX 265  
OGDENSBURG, NY  
U.S.A. 13669-0265  
TEL: (315) 472-5270  
FAX: (613) 226-2802

TEL: 1-800-265-6681  
FAX: 1-800-561-1970

e-mail: [info@avtechpulse.com](mailto:info@avtechpulse.com)  
<http://www.avtechpulse.com/>

☒ BOX 5120, LCD MERIVALE  
OTTAWA, ONTARIO  
CANADA K2C 3H4  
TEL: (613) 226-5772  
FAX: (613) 226-2802

## INSTRUCTIONS

MODEL AVO-9A-B-P2-P

0 TO 200 mA, 200 ps RISE TIME

HIGH PERFORMANCE LASER DIODE DRIVER

WITH PLUG-IN SOCKET OUTPUT MODULE

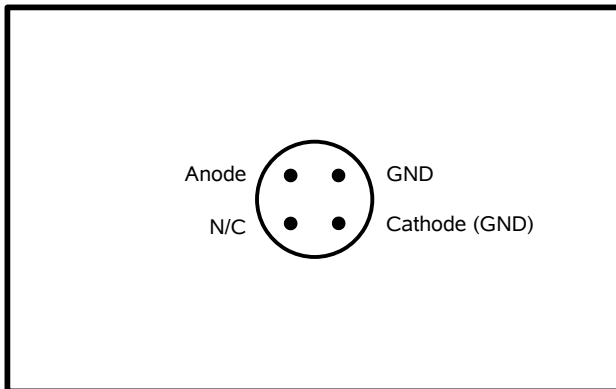

AVX-S1 OUTPUT MODULE, SOCKET VIEW

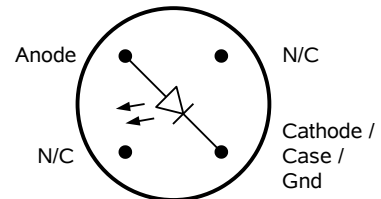

**MATCHING USER-SUPPLIED  
DIODE PACKAGE  
(TOP VIEW).  
TO-46 PACKAGE.**

SERIAL NUMBER: \_\_\_\_\_

### WARRANTY

Avtech Electrosystems Ltd. warrants products of its manufacture to be free from defects in material and workmanship under conditions of normal use. If, within one year after delivery to the original owner, and after prepaid return by the original owner, this Avtech product is found to be defective, Avtech shall at its option repair or replace said defective item. This warranty does not apply to units which have been disassembled, modified or subjected to conditions exceeding the applicable specifications or ratings. This warranty is the extent of the obligation assumed by Avtech with respect to this product and no other warranty or guarantee is either expressed or implied.

### TECHNICAL SUPPORT

Phone: 613-226-5772 or 1-800-265-6681

Fax: 613-226-2802 or 1-800-561-1970

E-mail: [info@avtechpulse.com](mailto:info@avtechpulse.com)

World Wide Web: <http://www.avtechpulse.com>

## TABLE OF CONTENTS

<b>WARRANTY.....</b>	<b>2</b>
<b>TECHNICAL SUPPORT.....</b>	<b>2</b>
<b>TABLE OF CONTENTS.....</b>	<b>3</b>
<b>INTRODUCTION.....</b>	<b>5</b>
<b>SPECIFICATIONS.....</b>	<b>6</b>
<b>ORIGINAL QUOTATION.....</b>	<b>7</b>
<b>EUROPEAN REGULATORY NOTES.....</b>	<b>10</b>
EC DECLARATION OF CONFORMITY.....	10
DIRECTIVE 2002/95/EC (RoHS).....	10
<b>INSTALLATION.....</b>	<b>11</b>
VISUAL CHECK.....	11
POWER RATINGS.....	11
CONNECTION TO THE POWER SUPPLY.....	11
PROTECTION FROM ELECTRIC SHOCK.....	12
ENVIRONMENTAL CONDITIONS.....	12
LABVIEW DRIVERS.....	13
<b>FUSES.....</b>	<b>14</b>
AC FUSE REPLACEMENT.....	14
DC FUSE REPLACEMENT.....	15
FUSE RATINGS.....	15
<b>FRONT PANEL CONTROLS.....</b>	<b>16</b>
<b>REAR PANEL CONTROLS.....</b>	<b>18</b>
<b>GENERAL INFORMATION.....</b>	<b>20</b>
MINIMAL TEST ARRANGEMENT - WITHOUT OUTPUT MODULE.....	20
NORMAL TEST ARRANGEMENT.....	21
AMPLITUDE CONTROL.....	22
BASIC PULSE CONTROL.....	23
TRIGGER MODES.....	24
GATING MODES.....	25
PULSE WIDTH / AMPLITUDE INTERACTION.....	25
<b>PROTECTING YOUR INSTRUMENT.....</b>	<b>26</b>
DO NOT EXCEED 1 MHz.....	26
USE A 50Ω LOAD.....	26

<b>OPERATIONAL CHECK</b> .....	<b>27</b>
<b>PROGRAMMING YOUR PULSE GENERATOR</b> .....	<b>31</b>
KEY PROGRAMMING COMMANDS.....	31
ALL PROGRAMMING COMMANDS.....	32
<b>MECHANICAL INFORMATION</b> .....	<b>34</b>
TOP COVER REMOVAL.....	34
RACK MOUNTING.....	34
ELECTROMAGNETIC INTERFERENCE.....	34
<b>MAINTENANCE</b> .....	<b>35</b>
REGULAR MAINTENANCE.....	35
CLEANING.....	35
<b>WIRING DIAGRAMS</b> .....	<b>0</b>
WIRING OF AC POWER 1/2.....	0
WIRING OF AC POWER 2/2.....	1
PCB 158J - LOW VOLTAGE POWER SUPPLY, 1/3.....	2
PCB 158J - LOW VOLTAGE POWER SUPPLY, 2/3.....	3
PCB 158J - LOW VOLTAGE POWER SUPPLY, 3/3.....	4
PCB 168B - HIGH VOLTAGE DC POWER SUPPLY.....	5
PCB 104D - KEYPAD / DISPLAY BOARD, 1/3.....	6
PCB 104D - KEYPAD / DISPLAY BOARD, 2/3.....	7
PCB 104D - KEYPAD / DISPLAY BOARD, 3/3.....	8
MAIN WIRING - POSITIVE UNITS.....	9
<b>PERFORMANCE CHECKSHEET</b> .....	<b>0</b>

Manual Reference: /fileserver1/officefiles/instructword/avo-9/AVO-9A-B-P2-P,edition1.sxw.

Last modified February 29, 2024.

Copyright © 2024 Avtech Electrosystems Ltd, All Rights Reserved.

## INTRODUCTION

The AVO-9A-B-P2-P is a high performance, GPIB and RS232-equipped instrument capable of generating up to 200 mA of current into diode loads, at repetition rates up to 20 kHz.

The AVO-9A-B-P2-P consists of a mainframe unit and an AVX-S1 series output module, which provides a socket into which the user's laser diode may be inserted. The mainframe generates voltage pulses of between 0 and +13V. The output module connects to the instrument mainframe via a detachable 2 foot long coaxial cable. The output module contains the necessary elements to match the laser diode to the pulse generator mainframe. A DC bias current of 0 to +100 mA may be applied to the laser diode by applying the desired DC current to a solder terminal on the output module. The output modules include an SMA output connector that provides an attenuated coincident replica of the diode current.

The AVO-9A-B-P2-P is a highly flexible instrument. Aside from the internal trigger source, it can also be triggered or gated by external TTL-level signals. A front-panel pushbutton or a computer command can also be used to trigger the instrument.

The AVO-9A-B-P2-P features front panel keyboard and adjust knob control of the output pulse parameters along with a four line by 40-character backlit LCD display of the output amplitude, pulse width, pulse repetition frequency, and delay. The instrument includes memory to store up to four complete instrument setups. The operator may use the front panel or the computer interface to store a complete "snapshot" of all key instrument settings, and recall this setup at a later time.

This instrument is intended for use in research, development, test and calibration laboratories by qualified personnel.

## SPECIFICATIONS

Model:	AVO-9A-B-P2-P <sup>2</sup>
Amplitude <sup>3,4</sup> :	0 to 200 mA
Maximum voltage output of mainframe (V <sub>MAINFRAME</sub> ):	13V
Allowed load voltage range:	0 to 3V. (Contact Avtech if your diode has a higher forward voltage drop)
Pulse width (FWHM):	0.4 to 4 ns
PRF:	1 Hz to 1 MHz
Rise and fall times (20%-80%):	≤ 200 ps
Related 50Ω series:	AVP-AV-1
Polarity <sup>8</sup> :	Positive
GPB and RS-232 control <sup>2</sup> :	Standard on -B units.
LabView drivers:	-B units only: check <a href="http://www.avtechpulse.com/labview">http://www.avtechpulse.com/labview</a> for availability and downloads
Telnet / Ethernet control <sup>9</sup> :	Optional for -B units. See <a href="http://www.avtechpulse.com/options/tnt">http://www.avtechpulse.com/options/tnt</a> for details
Propagation delay: (Ext trig in to pulse out)	≤ 150 ns
Jitter: (Ext trig in to pulse out)	± 35 ps ± 0.015% of sync delay
DC offset or bias insertion:	Apply required DC bias current in the range of ± 100 mA to solder terminal on output module.
Sync delay:	Variable 0 to ± 1 s (sync out to pulse out)
Sync output (to 50Ω):	+ 3 Volts, 100 ns
Gate input:	Synchronous or asynchronous, active high or low, switchable. Suppresses triggering when active.
Trigger required: (ext trig mode)	+ 5 V (TTL), ≥ 50 ns
Connectors: Out: Other:	User-specified socket. Trig, Sync, Gate: BNC, Monitor: SMA
Power requirements:	100 - 240 Volts, 50 - 60 Hz
Dimensions: (H x W x D) Mainframe: Output module:	100 x 430 x 375 mm (3.9" x 17" x 14.8"), anodized aluminum, with blue plastic trim 41 x 66 x 76 mm (1.6" x 2.6" x 3.0"), cast aluminum, blue enamel
Temperature range:	+5°C to +40°C

- 1) -C suffix indicates stand-alone lab instrument with internal clock and line powering. (See <http://www.avtechpulse.com/formats/> for details of the instrument formats).
- 2) -B suffix indicates IEEE-488.2 GPIB and RS-232 control of amplitude and frequency. See <http://www.avtechpulse.com/gpib/> for details.
- 3) For operation at amplitudes of less than 20% of full-scale, best results will be obtained by setting the amplitude near full-scale and using external attenuators on the output, between the mainframe and the output module.
- 4) For analog electronic control (0 to +10V) of amplitude suffix model number with -EA. Electronic control units also include standard front-panel controls.
- 5) Add the suffix -HC to the model number to specify the current-doubling option.
- 6) For rise times variable from 300 ps to 2.0 ns via a five-position switch add suffix -TR (option). TR switch also affects fall time. Without -TR, the rise and fall times are fixed at 300 ps.
- 7) Standard unit has rise and fall times fixed at 3.0 ns. For rise, fall times separately switchable from 3.0 ns to 0.3 ns (two 2-position switches) add suffix -TRF (option). Not available on -B units.
- 8) Indicate desired polarity by suffixing model number with -P or -N (i.e. positive or negative).
- 9) Add the suffix -TNT to the model number to specify the Telnet / Ethernet control option.

## ORIGINAL QUOTATION

Date: Wed, 29 Jun 2005 10:12:08 -0400  
From: "Dr. Michael J. Chudobiak"  
Subject: Avtech pulse generator quotes

XXXXX,

We spoke earlier today about your interest in the AVO-9A and AVO-9C series of pulsed laser diode drivers.

Each AVO-9A and AVO-9C model is provided with an output module that contains a high-speed socket. The socket is customized to meet the pinout requirements of the user's diode. This makes the AVO-9 easy to use with packaged diodes, and the user does not require familiarity with high-speed circuit construction techniques to obtain good results. However, as we discussed, it is a little difficult to directly measure the diode current because two measurements must be taken (from the "MV" and "MI" outputs to calculate the current.

Also, if you are planning to drive unpackaged diodes, or a variety of different diodes, the output module might not be useful to you. You might prefer to use a high-speed 50 Ohm pulse generator such as the AVP-AV-1-B or AVPP-1-B to drive your diode in series with a 50 Ohm resistance. The 50 Ohm series resistor is required to limit the current and to terminate the coaxial cabling. If the diode is placed between the pulser and the resistor, and one end of the resistor is connected to ground, the voltage across the resistor will be proportional to the diode current. This provides a simple way of measuring the diode current. However, to obtain good results, you must be familiar with high-speed construction techniques (microstrip, etc) and minimize and parasitic inductance and capacitance.

The AVO-9A and AVO-9C models can be used without their output modules, to drive 50 Ohm + diode loads directly.

For all of the above pulsers, attenuators can added on the instrument mainframe output to limit the maximum possible current to lower levels.

I am pleased to quote on four possible models that may be of interest:

Quote number: 12653.01

Model number: AVO-9A-B-P2-P

Description: Laser Diode Driver (Pulsed Voltage) with IEEE-488.2 GPIB and RS-232 Computer Control Ports and an Output Module for 5.6 mm packaged diodes. 200 mA maximum, 0.4 to 4 ns pulse width, 1 MHz.

Polarity: positive

Pricing, manuals, datasheets: <http://www.avtechpulse.com/laser/avo-9a>

PDF datasheet:

[http://www.avtechpulse.com/laser/avo-9a/page064\\_cat11\\_avo-9\\_rev4.pdf](http://www.avtechpulse.com/laser/avo-9a/page064_cat11_avo-9_rev4.pdf)

Price: \$XXXXX\* US each, CIF Ireland. Includes the cost of freight and insurance, but excludes customs duties, taxes, and other fees.

\* PRICING CAN NOT BE CONFIRMED until a drawing showing the diode package size and electrical pinout is provided by the end-user. The output module socket must be designed specifically to mate with the user's diode package.

Optional: An Internet control (Telnet and Web) option is available for an additional \$598. Add the suffix "-TNT" to the model number to specify

this option. Additional details about this option are available at <http://www.avtechpulse.com/options/tnt>.

Quote valid for: 60 days

Estimated delivery: 45-60 days after receipt of order (excluding export permit\*\* delays).

Quote number: 12653.02

Model number: AV0-9C-C-P2-P

Description: Laser Diode Driver (Pulsed Voltage) including an Output Module for 5.6 mm packaged diodes. No GPIB. 100 mA maximum, 0.5 to 10 ns pulse width, 25 MHz.

Polarity: positive

Pricing, manuals, datasheets: <http://www.avtechpulse.com/laser/avo-9c>

PDF datasheet:

[http://www.avtechpulse.com/laser/avo-9c/page064\\_cat11\\_avo-9\\_rev4.pdf](http://www.avtechpulse.com/laser/avo-9c/page064_cat11_avo-9_rev4.pdf)

Price: \$XXXXX\* US each, CIF Ireland. Includes the cost of freight and insurance, but excludes customs duties, taxes, and other fees.

\* PRICING CAN NOT BE CONFIRMED until a drawing showing the diode package size and electrical pinout is provided by the end-user. The output module socket must be designed specifically to mate with the user's diode package.

Quote valid for: 60 days

Estimated delivery: 45-60 days after receipt of order (excluding export permit\*\* delays).

Quote number: 12653.03

Model number: AVP-AV-1-B-P

Description: Ultra High Speed Pulse Generator with IEEE-488.2 GPIB and RS-232 Computer Control Ports. No output module. 10V into 50 Ohms (200 mA maximum), 0.4 to 4 ns pulse width, 1 MHz.

Polarity: positive

Pricing, manuals, datasheets: <http://www.avtechpulse.com/speed/avp-av-1>

PDF datasheet:

[http://www.avtechpulse.com/speed/avp-av-1/page024\\_cat11\\_avp\\_rev11.pdf](http://www.avtechpulse.com/speed/avp-av-1/page024_cat11_avp_rev11.pdf)

Price: \$XXXXX US each, CIF Ireland. Includes the cost of freight and insurance, but excludes customs duties, taxes, and other fees.

Optional: An Internet control (Telnet and Web) option is available for an additional \$598. Add the suffix "-TNT" to the model number to specify this option. Additional details about this option are available at <http://www.avtechpulse.com/options/tnt>.

Quote valid for: 60 days

Estimated delivery: 45-60 days after receipt of order (excluding export permit\* delays).

Quote number: 12653.04



Model number: AVPP-1-B-P

Description: Ultra High Speed Pulse Generator with IEEE-488.2 GPIB and RS-232 Computer Control Ports. No output module. 10V into 50 Ohms (200 mA maximum), 0.4 to 100 ns pulse width, 1 MHz.

Polarity: positive

Pricing, manuals, datasheets: <http://www.avtechpulse.com/speed/avpp-1>

PDF datasheet:

[http://www.avtechpulse.com/speed/avpp-1/page026\\_cat11\\_avpp\\_revision4.pdf](http://www.avtechpulse.com/speed/avpp-1/page026_cat11_avpp_revision4.pdf)

Price: \$XXXXX US each, CIF Ireland. Includes the cost of freight and insurance, but excludes customs duties, taxes, and other fees.

Optional: An Internet control (Telnet and Web) option is available for an additional \$598. Add the suffix "-TNT" to the model number to specify this option. Additional details about this option are available at <http://www.avtechpulse.com/options/tnt>.

Quote valid for: 60 days

Estimated delivery: 45-60 days after receipt of order (excluding export permit\* delays).

\*Export Permit: These instruments are very high performance pulse generators, which are considered to be "Nuclear-Related Dual-Use Goods" under government regulations. As such, an "End Use Statement" must be completed when ordering. The necessary form is attached (in PDF format). We will use the information in the completed form to apply for an export license from the Canadian government, which will take 1 to 6 weeks to obtain. We cannot ship your order without the license. Please return the completed form to us by fax.

50 Ohm pulsers with wider pulse width ranges are also available. Let me know if you need other model suggestions.

Please call or email me if I can be of further assistance.

Thank you for your interest in our products!

Regards,

Dr. Michael J. Chudobiak  
Chief Engineer

--- Avtech Electrosystems Ltd. ----- since 1975 ---

PO Box 265	ph: 1-800-265-6681 or 613-226-5772	Box 5120
Ogdensburg	fax: 1-800-561-1970 or 613-226-2802	LCD Merivale
New York	email: <a href="mailto:info@avtechpulse.com">info@avtechpulse.com</a>	Ottawa, Ontario
USA 13669-0265	<a href="http://www.avtechpulse.com/">http://www.avtechpulse.com/</a>	Canada K2C 3H4

Pulse Generators - Laser Diode Drivers - HV Amplifiers  
Monocycle Generators - Impulse Generators - Pulse Amplifiers  
Current Pulsers - Function Generators - Frequency Dividers - and more!

Free catalog & newsletter ~ <http://www.avtechpulse.com/request/>

Attachment: EndUse Statement generic3.pdf

## EUROPEAN REGULATORY NOTES

### EC DECLARATION OF CONFORMITY

We

Avtech Electrosystems Ltd.  
P.O. Box 5120, LCD Merivale  
Ottawa, Ontario  
Canada K2C 3H4

declare that this pulse generator meets the intent of Directive 89/336/EEC for Electromagnetic Compatibility. Compliance pertains to the following specifications as listed in the official Journal of the European Communities:

EN 50081-1 Emission

EN 50082-1 Immunity

and that this pulse generator meets the intent of the Low Voltage Directive 72/23/EEC as amended by 93/68/EEC. Compliance pertains to the following specifications as listed in the official Journal of the European Communities:

EN 61010-1:2001 Safety requirements for electrical equipment for measurement, control, and laboratory use



### DIRECTIVE 2002/95/EC (RoHS)

This instrument is exempt from Directive 2002/95/EC of the European Parliament and of the Council of 27 January 2003 on the Restriction of the use of certain Hazardous Substances (RoHS) in electrical and electronic equipment. Specifically, Avtech instruments are considered "Monitoring and control instruments" (Category 9) as defined in Annex 1A of Directive 2002/96/EC. The Directive 2002/95/EC only applies to Directive 2002/96/EC categories 1-7 and 10, as stated in the "Article 2 - Scope" section of Directive 2002/95/EC.

## INSTALLATION

### VISUAL CHECK

After unpacking the instrument, examine to ensure that it has not been damaged in shipment. Visually inspect all connectors, knobs, liquid crystal displays (LCDs), and the handles. Confirm that a power cord, a GPIB cable, two instrumentation manuals (this manual and the “Programming Manual for -B Instruments”), and the output module are with the instrument. If the instrument has been damaged, file a claim immediately with the company that transported the instrument.

### POWER RATINGS

This instrument is intended to operate from 100 - 240 V, 50 - 60 Hz.

The maximum power consumption is 57 Watts. Please see the “FUSES” section for information about the appropriate AC and DC fuses.

This instrument is an “Installation Category II” instrument, intended for operation from a normal single-phase supply.

### CONNECTION TO THE POWER SUPPLY

An IEC-320 three-pronged recessed male socket is provided on the back panel for AC power connection to the instrument. One end of the detachable power cord that is supplied with the instrument plugs into this socket. The other end of the detachable power cord plugs into the local mains supply. Use only the cable supplied with the instrument. The mains supply must be earthed, and the cord used to connect the instrument to the mains supply must provide an earth connection. (The supplied cord does this.)

 Warning: Failure to use a grounded outlet may result in injury or death due to electric shock. This product uses a power cord with a ground connection. It must be connected to a properly grounded outlet. The instrument chassis is connected to the ground wire in the power cord.

The table below describes the power cord that is normally supplied with this instrument, depending on the destination region:

Destination Region	Description	Manufacturer	Part Number
Continental Europe	European CEE 7/7 "Schuko" 230V, 50Hz	Volex ( <a href="http://www.volex.com">http://www.volex.com</a> )	17850-C3-326
		Qualtek ( <a href="http://www.qualtekusa.com">http://www.qualtekusa.com</a> )	319004-T01
United Kingdom	BS 1363, 230V, 50Hz	Qualtek ( <a href="http://www.qualtekusa.com">http://www.qualtekusa.com</a> )	370001-E01
Switzerland	SEV 1011, 2 30V, 50Hz	Volex ( <a href="http://www.volex.com">http://www.volex.com</a> )	2102H-C3-10
Israel	SI 32, 220V, 50Hz	Volex ( <a href="http://www.volex.com">http://www.volex.com</a> )	2115H-C3-10
North America, and all other areas	NEMA 5-15, 120V, 60 Hz	Qualtek ( <a href="http://www.qualtekusa.com">http://www.qualtekusa.com</a> )	312007-01

### PROTECTION FROM ELECTRIC SHOCK

 Operators of this instrument must be protected from electric shock at all times. The owner must ensure that operators are prevented access and/or are insulated from every connection point. In some cases, connections must be exposed to potential human contact. Operators must be trained to protect themselves from the risk of electric shock. This instrument is intended for use by qualified personnel who recognize shock hazards and are familiar with safety precautions required to avoid possibly injury. In particular, operators should:

1. Keep exposed high-voltage wiring to an absolute minimum.
2. Wherever possible, use shielded connectors and cabling.
3. Connect and disconnect loads and cables only when the instrument is turned off.
4. Keep in mind that all cables, connectors, oscilloscope probes, and loads must have an appropriate voltage rating.
5. Do not attempt any repairs on the instrument, beyond the fuse replacement procedures described in this manual. Contact Avtech technical support (see page 2 for contact information) if the instrument requires servicing. Service is to be performed solely by qualified service personnel.

### ENVIRONMENTAL CONDITIONS

This instrument is intended for use under the following conditions:

1. indoor use;
2. altitude up to 2 000 m;
3. temperature 5 °C to 40 °C;

4. maximum relative humidity 80 % for temperatures up to 31 °C decreasing linearly to 50 % relative humidity at 40 °C;
5. Mains supply voltage fluctuations up to  $\pm 10$  % of the nominal voltage;
6. no pollution or only dry, non-conductive pollution.

#### LABVIEW DRIVERS

A LabVIEW driver for this instrument is available for download on the Avtech web site, at <http://www.avtechpulse.com/labview>. A copy is also available in National Instruments' Instrument Driver Library at <http://www.natinst.com/>.

## FUSES

This instrument contains four fuses. All are accessible from the rear-panel. Two protect the AC prime power input, and two protect the internal DC power supplies. The locations of the fuses on the rear panel are shown in the figure below:

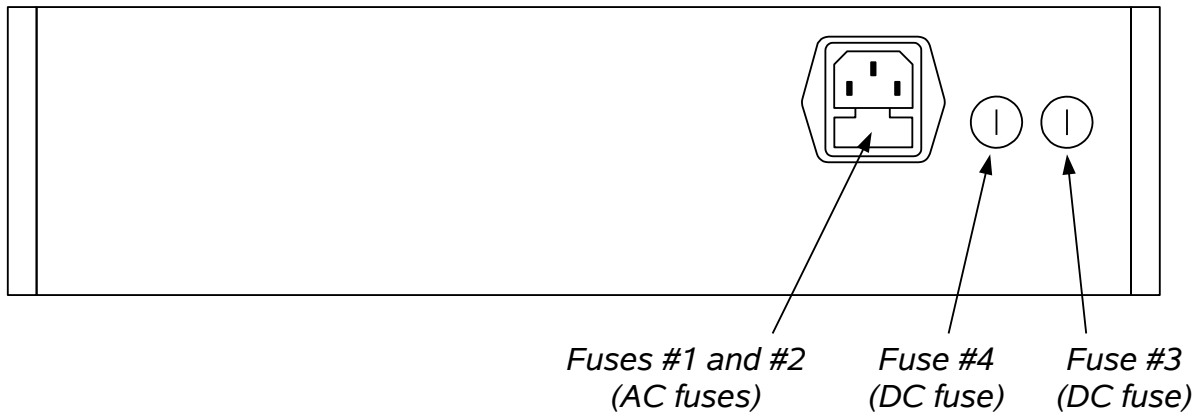

### AC FUSE REPLACEMENT

To physically access the AC fuses, the power cord must be detached from the rear panel of the instrument. The fuse drawer may then be extracted using a small flat-head screwdriver, as shown below:

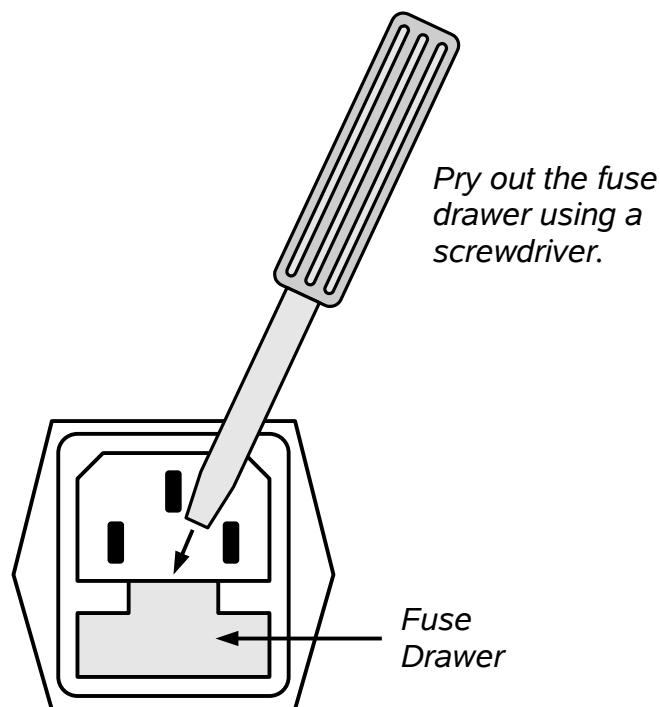

## DC FUSE REPLACEMENT

The DC fuses may be replaced by inserting the tip of a flat-head screwdriver into the fuse holder slot, and rotating the slot counter-clockwise. The fuse and its carrier will then pop out.

## FUSE RATINGS

The following table lists the required fuses:

Fuses	Nominal Mains Voltage	Rating	Case Size	Manufacturer's Part Number (Wickmann)	Distributor's Part Number (Digi-Key)
#1, #2 (AC)	100-240V	0.5A, 250V, Time-Delay	5×20 mm	1950500000	WK5041-ND
#3 (DC)	N/A	1.0A, 250V, Time-Delay	5×20 mm	1951100000	WK5048-ND
#4 (DC)	N/A	0.25A, 250V, Time-Delay	5×20 mm	1950250000	WK5035-ND

The fuse manufacturer is Wickmann (<http://www.wickmann.com/>).

Replacement fuses may be easily obtained from Digi-Key (<http://www.digikey.com/>) and other distributors.

## FRONT PANEL CONTROLS

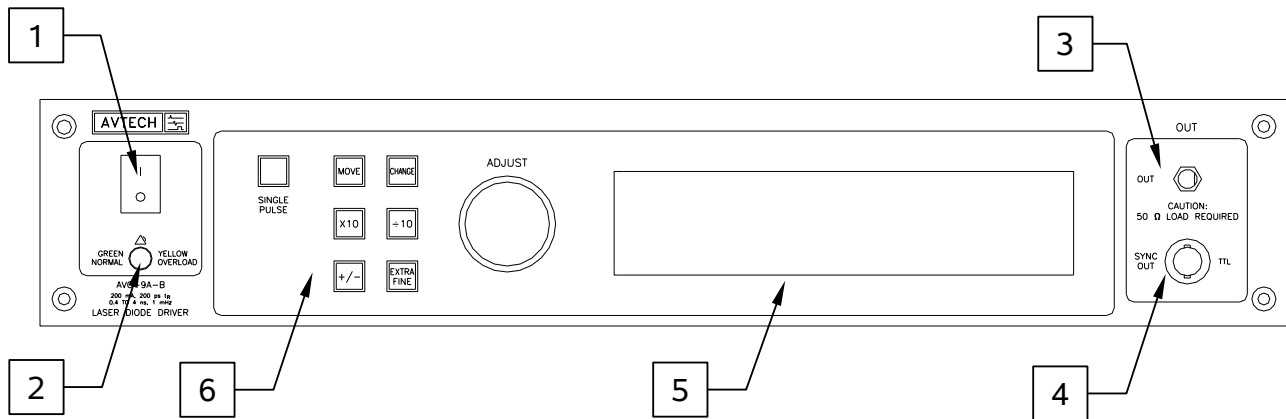

1. POWER Switch. This is the main power switch. When turning the instrument on, there may be a delay of several seconds before the instrument appears to respond.
2. OVERLOAD Indicator. When the instrument is powered, this indicator is normally green, indicating normal operation. If this indicator is yellow, an internal automatic overload protection circuit has been tripped. If the unit is overloaded (by operating at an exceedingly high duty cycle or by operating into a very low impedance), the protective circuit will disable the output of the instrument and turn the indicator light yellow. The light will stay yellow (i.e. output disabled) for about 5 seconds after which the instrument will attempt to re-enable the output (i.e. light green) for about 1 second. If the overload condition persists, the output will be disabled again (i.e. light yellow) for another 5 seconds. If the overload condition has been removed, the instrument will resume normal operation.

This overload indicator may flash yellow briefly at start-up. This is not a cause for concern.

3. OUT CONNECTOR. This SMA connector is connected to the output module, when the output module is used to drive a diode load. If the output module is not used, this output will generate up to 13V into a load impedances of 50Ω. (NOTE: when the output module is not used, this output *requires* a 50Ω load to function properly).
4. SYNC OUT. This connector supplies a SYNC output that can be used to trigger other equipment, particularly oscilloscopes. This signal leads (or lags) the main output by a duration set by the "DELAY" controls and has an approximate amplitude of +3 Volts to  $R_L > 1k\Omega$  with a pulse width of approximately 100 ns.
5. LIQUID CRYSTAL DISPLAY (LCD). This LCD is used in conjunction with the keypad to change the instrument settings. Normally, the main menu is displayed, which lists the key adjustable parameters and their current values. The "Programming Manual for -B Instruments" describes the menus and submenus in detail.



6. KEYPAD.

Control Name	Function
MOVE	This moves the arrow pointer on the display.
CHANGE	This is used to enter the submenu, or to select the operating mode, pointed to by the arrow pointer.
×10	If one of the adjustable numeric parameters is displayed, this increases the setting by a factor of ten.
÷10	If one of the adjustable numeric parameters is displayed, this decreases the setting by a factor of ten.
+/-	If one of the adjustable numeric parameters is displayed, and this parameter can be both positive or negative, this changes the sign of the parameter.
EXTRA FINE	This changes the step size of the ADJUST knob. In the extra-fine mode, the step size is twenty times finer than in the normal mode. This button switches between the two step sizes.
ADJUST	This large knob adjusts the value of any displayed numeric adjustable values, such as frequency, pulse width, etc. The adjust step size is set by the "EXTRA FINE" button.  When the main menu is displayed, this knob can be used to move the arrow pointer.

## REAR PANEL CONTROLS

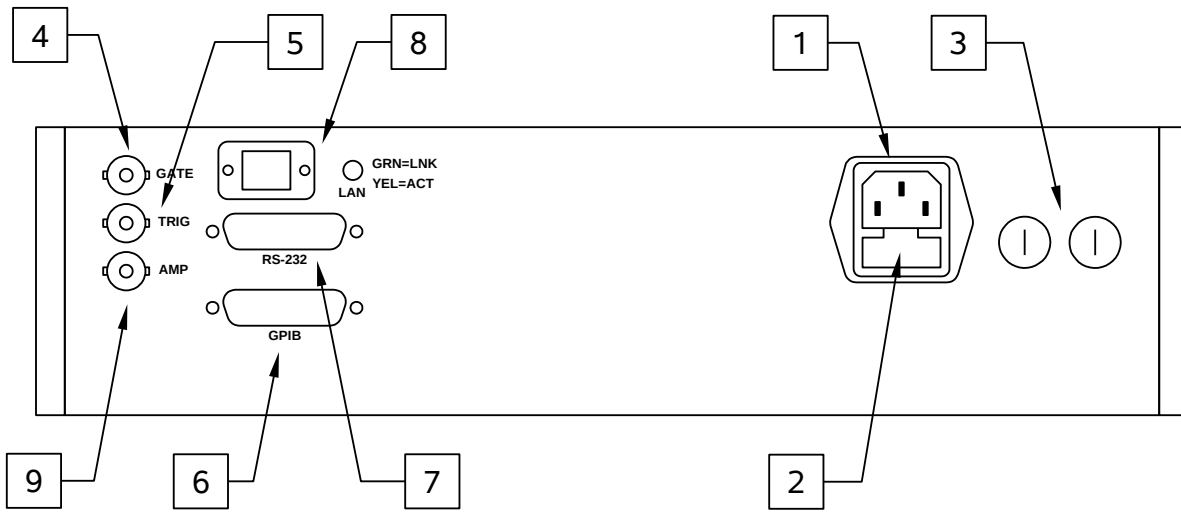

1. AC POWER INPUT. An IEC-320 C14 three-pronged recessed male socket is provided on the back panel for AC power connection to the instrument. One end of the detachable power cord that is supplied with the instrument plugs into this socket.
2. AC FUSE DRAWER. The two fuses that protect the AC input are located in this drawer. Please see the “FUSES” section of this manual for more information.
3. DC FUSES. These two fuses protect the internal DC power supplies. Please see the “FUSES” sections of this manual for more information.
4. GATE. This TTL-level (0 and +5V) logic input can be used to gate the triggering of the instrument. This input can be either active high or active low, depending on the front panel settings or programming commands. (The instrument triggers normally when this input is unconnected). When set to active high mode, this input is pulled-down to ground by a 1 k $\Omega$  resistor. When set to active low mode, this input is pulled-up to +5V by a 1 k $\Omega$  resistor.
5. TRIG. This TTL-level (0 and +5V) logic input can be used to trigger the instrument, if the instrument is set to triggering externally. The instrument triggers on the rising edge of this input. The input impedance of this input is 1 k $\Omega$ . (Depending on the length of cable attached to this input, and the source driving it, it may be desirable to add a coaxial 50 Ohm terminator to this input to provide a proper transmission line termination. The Pasternack ([www.pasternack.com](http://www.pasternack.com)) PE6008-50 BNC feed-thru 50 Ohm terminator is suggested for this purpose.)

When triggering externally, the instrument can be set such that the output pulse width tracks the pulse width on this input, or the output pulse width can be set independently.

6. GPIB Connector. A standard GPIB cable can be attached to this connector to allow the instrument to be computer-controlled. See the "Programming Manual for -B Instruments" for more details on GPIB control.
7. RS-232 Connector. A standard serial cable with a 25-pin male connector can be attached to this connector to allow the instrument to be computer-controlled. See the "Programming Manual for -B Instruments" for more details on RS-232 control.
8. LAN Connector and Indicator. (Optional feature. Present on -TNT units only.) The -TNT option "Internet-enables" Avtech pulse generators by adding this standard Ethernet port to the rear panel, in addition to the IEEE-488.2 GPIB and RS-232 ports normally found on "-B" units. Commands are sent using the standard Telnet protocol. The SCPI-compliant command set is the same as that used for GPIB and RS-232 control. The -TNT option uses the Dynamic Host Configuration Protocol (DHCP) to obtain its network address. A DHCP server must be present on the local network for the -TNT option to operate properly.
9. AMP Connector. (Optional feature. Present on -EA units only.) The output amplitude can be set to track the voltage on this input. Zero Volts in corresponds to zero amplitude output, and +10V in corresponds to maximum amplitude out. This mode is activated by selecting "Ext Control" on the front-panel amplitude menu, or with the "source:voltage external" command.

## GENERAL INFORMATION

### MINIMAL TEST ARRANGEMENT - WITHOUT OUTPUT MODULE

The AVO-9A-B-P2-P can be tested initially without the supplied output module. If the output module is not used, the mainframe output generates 0 to +13 Volts (for -P units), or 0 to -13 V (for -N units), into a 50 Ohm load, as illustrated below:

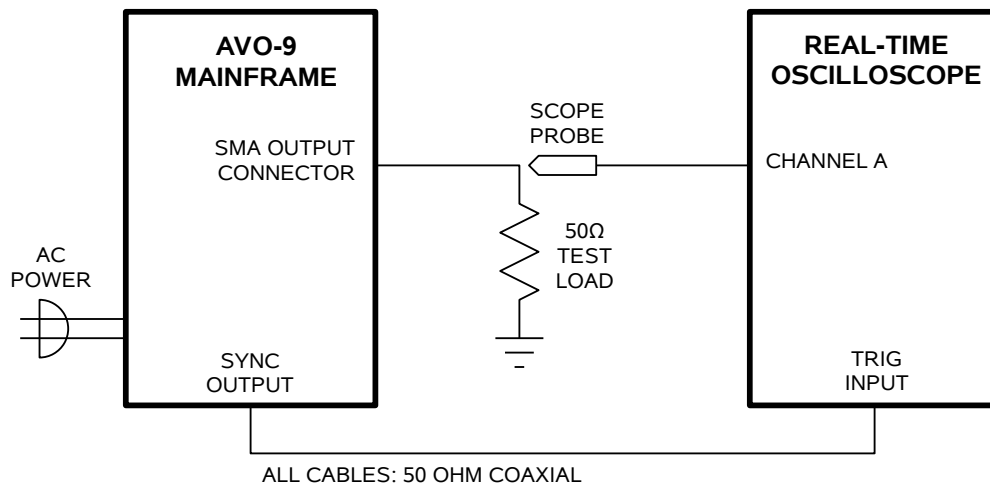

Since the AVO-9A-B-P2-P can generate pulses with rise times as low as 200 ps, it may be necessary to use a sampling oscilloscope, rather than a real-time oscilloscope. In this case, the test arrangement should be altered as shown below:

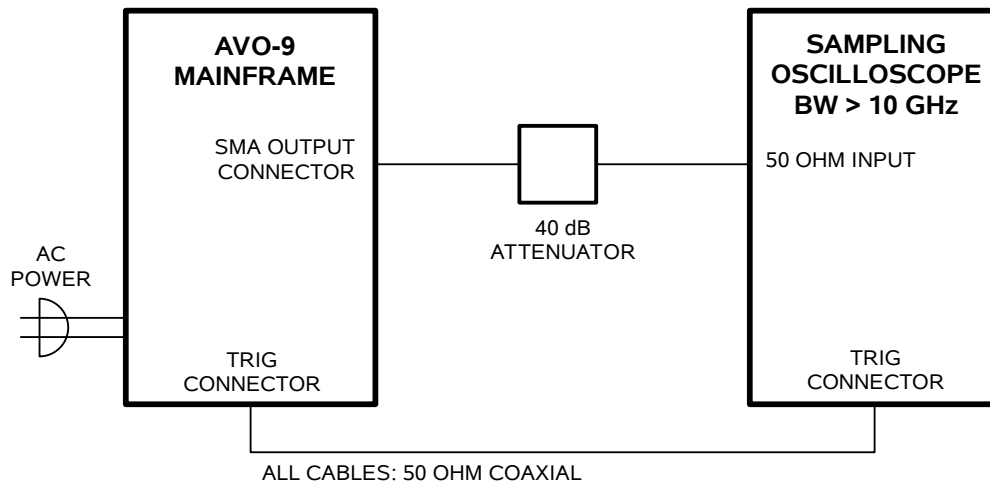

Since most sampling oscilloscopes have limited input amplitude ranges, attenuators are required. Select appropriate attenuators for your oscilloscope.

When the output module is not used, a 50 Ohm load impedance is *required* for proper test operation.

## NORMAL TEST ARRANGEMENT

To fully test the instrument, and for normal operation, the output module must be connected as shown below:

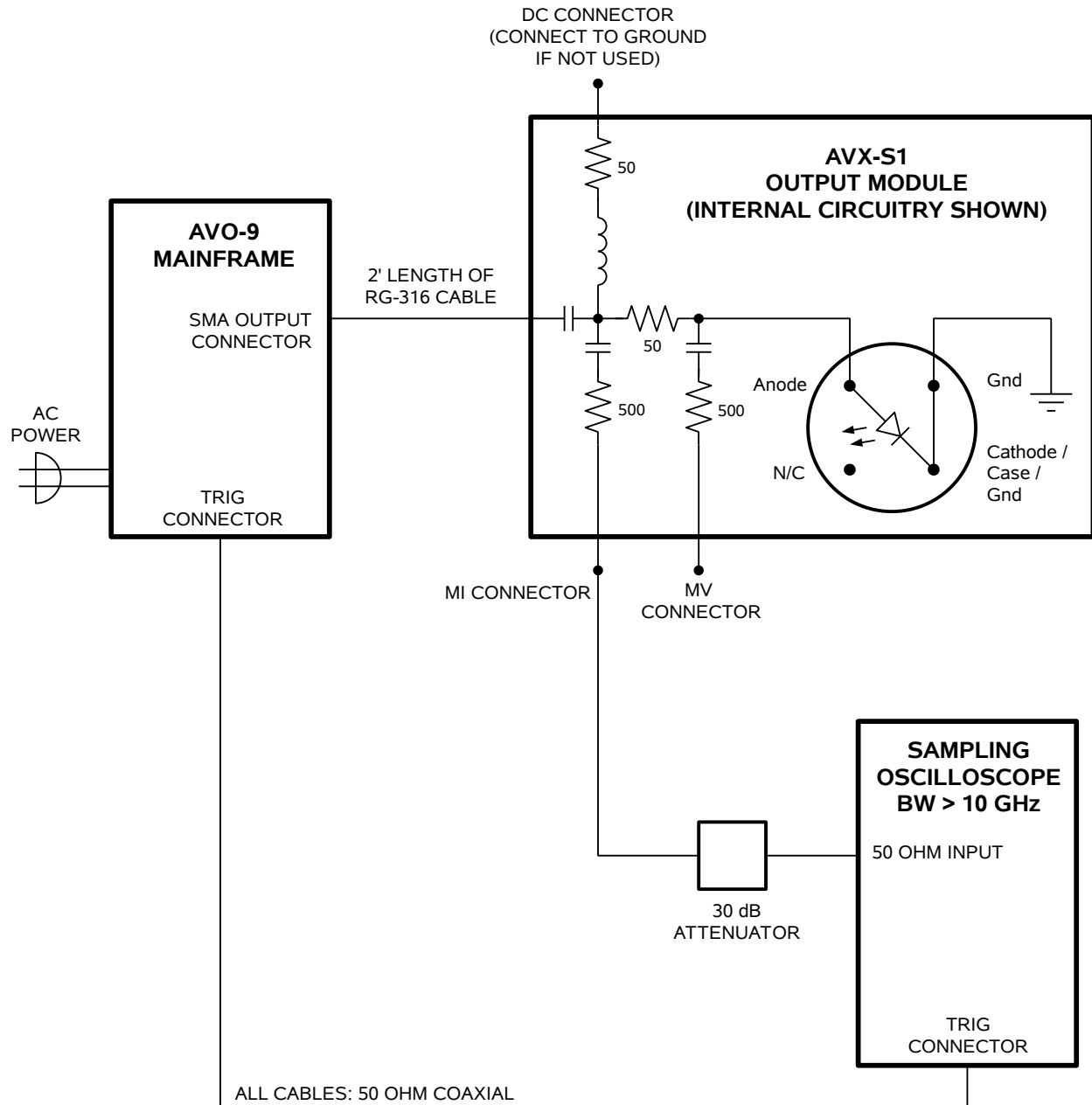

The diode load is inserted into the socket on the output module. The physical layout of the socket is shown below:

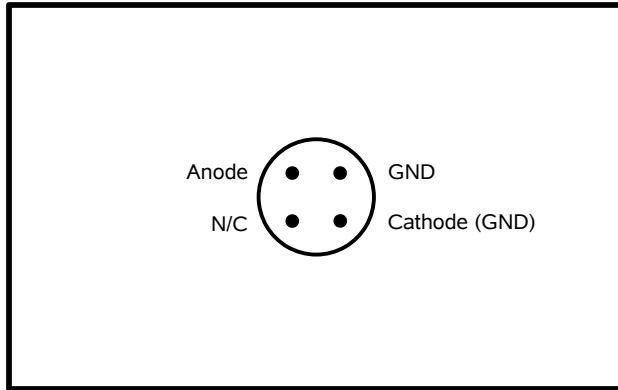

**AVX-S1 OUTPUT MODULE, SOCKET VIEW**

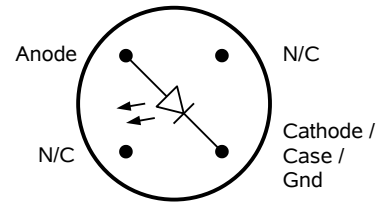

**MATCHING USER-SUPPLIED  
DIODE PACKAGE  
(TOP VIEW).  
TO-46 PACKAGE.**

An oscilloscope may be used to monitor the MI and MV outputs. A forward DC bias may be applied to the laser diode by connecting a DC potential of 0 to +10 Volts to the DC solder terminal. The application of a small forward bias often yields a more ideal diode current waveform (as observed on the MI port). Note that the DC port must be shorted to ground if a bias is not applied.

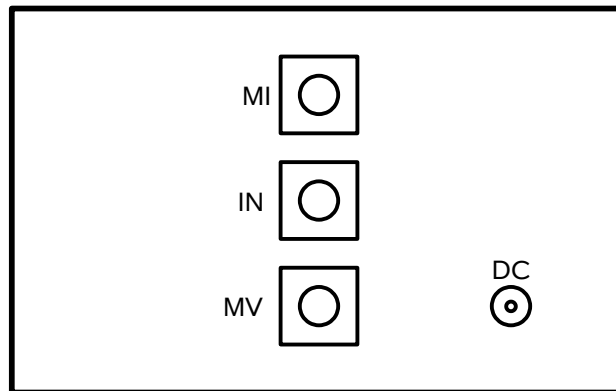

**AVX-S1 OUTPUT MODULE, CONNECTOR VIEW**

### AMPLITUDE CONTROL

When using the output module, the pulse current through the diode load is given by:

$$I_{\text{DIODE}} = (V_{\text{SET}} - V_{\text{DIODE}}) / 50\Omega$$

where  $V_{\text{SET}}$  is the amplitude setting on the mainframe (between 0 and 13V), and  $V_{\text{DIODE}}$  is the forward voltage drop across the diode (typically 2 or 3V).

## BASIC PULSE CONTROL

This instrument can be triggered by its own internal clock or by an external TTL trigger signal. In either case, two mainframe output channels respond to the trigger: OUT and SYNC.

- OUT. This is the main output. The maximum output voltage is 13V.
- SYNC. The SYNC pulse is a fixed-width TTL-level reference pulse used to trigger oscilloscopes or other measurement systems. When the delay is set to a positive value the SYNC pulse precedes the OUT pulse. When the delay is set to a negative value the SYNC pulse follows the OUT pulse.

These pulses are illustrated below, assuming internal triggering and a positive delay:

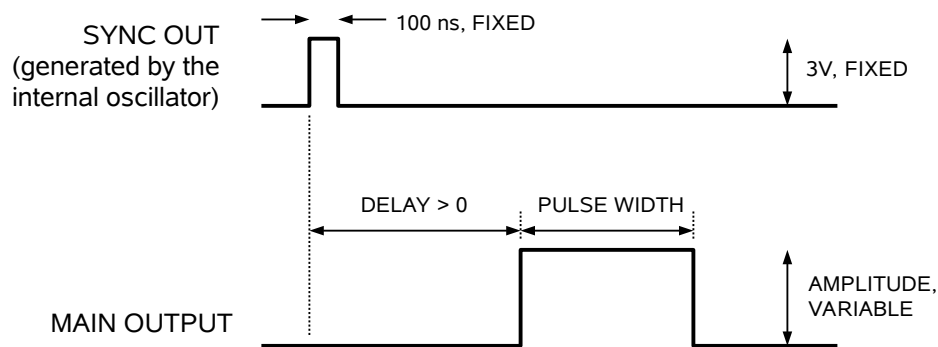

*Figure A*

If the delay is negative, the order of the SYNC and OUT pulses is reversed:

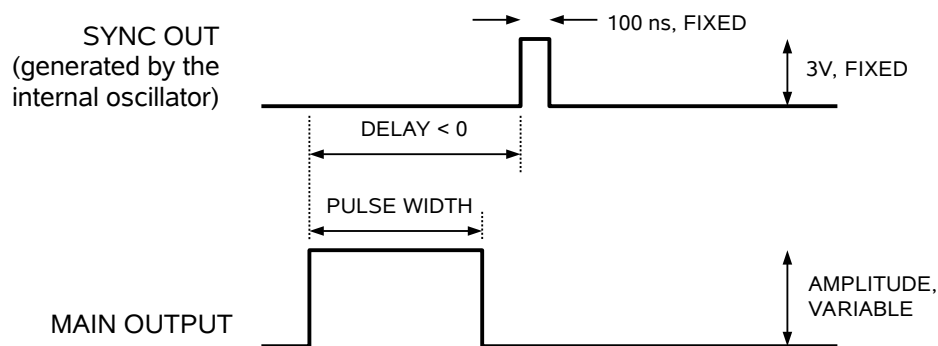

*Figure B*

The next figure illustrates the relationship between the signal when an external TTL-level trigger is used:

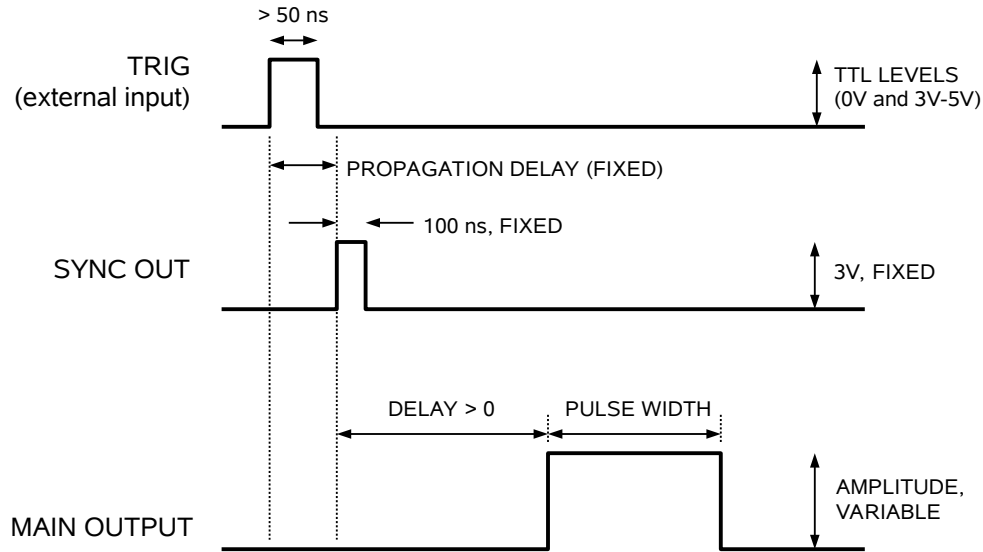

Figure C

As before, if the delay is negative, the order of the SYNC and OUT pulses is reversed.

In general, the delay, pulse width, and frequency (when in the internal mode), of the OUT pulse can be varied with front panel controls or via the GPIB or RS-232 computer interfaces.

### TRIGGER MODES

This instrument has four trigger modes:

- Internal Trigger: the instrument controls the trigger frequency, and generates the clock internally.
- External Trigger: the instrument is triggered by an external TTL-level clock on the back-panel TRIG connector.
- Manual Trigger: the instrument is triggered by the front-panel "SINGLE PULSE" pushbutton.
- Hold Trigger: the instrument is set to not trigger at all.

These modes can be selected using the front panel trigger menu, or by using the appropriate programming commands. (See the "Programming Manual for -B Instruments" for more details.)

**WARNING:** The output stage may be damaged if triggered by an external signal at a pulse repetition frequency greater than 1 MHz.



## GATING MODES

Triggering can be suppressed by a TTL-level signal on the rear-panel GATE connector. The instrument can be set to stop triggering when this input high or low, using the front-panel gate menu or the appropriate programming commands. When gated, the output will complete the full pulse width if the output is high, and then stop triggering. Pulses are not truncated.

## PULSE WIDTH / AMPLITUDE INTERACTION

The pulse width and delay of the output pulse may vary slightly with the amplitude setting, particularly at lower amplitudes. For some demanding applications, it may be desirable to use external attenuators in conjunction with the AVO-9A-B-P2-P, instead of generating a low-amplitude pulse directly.

## PROTECTING YOUR INSTRUMENT

### DO NOT EXCEED 1 MHz

The output stage may be damaged if triggered by an external signal at a pulse repetition frequency greater than 1 MHz.

### USE A 50Ω LOAD

The mainframe output stage may be damaged if the output is not terminated into the output module or a 50Ω dummy load.

## OPERATIONAL CHECK

This section describes a sequence to confirm the basic operation of the instrument. It should be performed after receiving the instrument. It is a useful learning exercise as well.

Before proceeding with this procedure, finish reading this instruction manual thoroughly. Then read the “Local Control” section of the “Programming Manual for -B Instruments” thoroughly. The “Local Control” section describes the front panel controls used in this operational check - in particular, the MOVE, CHANGE, and ADJUST controls.

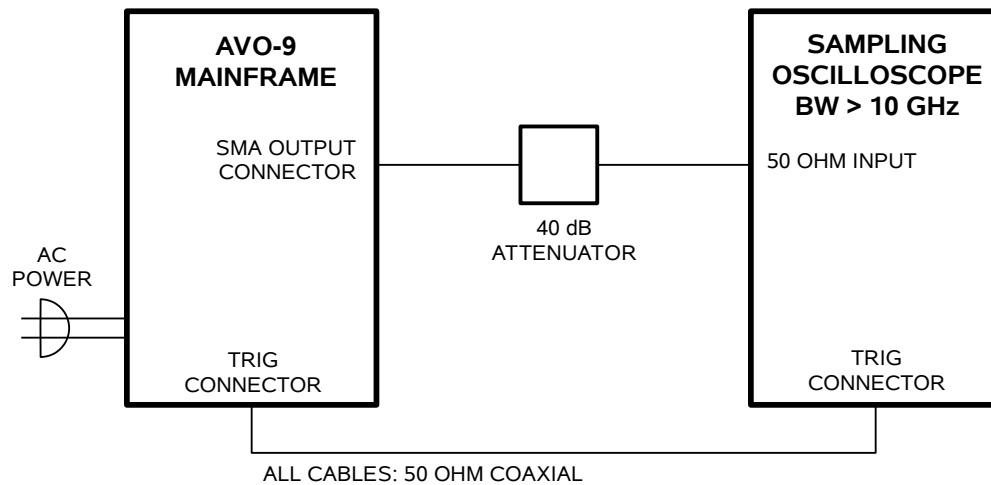

1. Connect the pulse generator to a sampling oscilloscope as shown above. Note that:
  - a) The use of 50 dB attenuator at the sampling scope vertical input channel will ensure a peak input signal to the sampling scope of less than 1 Volt.
  - b) The TRIG output channel provides TTL level signals (approximately 0 and +3V). To avoid overdriving the TRIG input channel of some scopes, a 20 dB attenuator may be needed at the input to the scope trigger channel.
  - c) The bandwidth capability of components and instruments used to display the pulse generator output signal (attenuators, cables, connectors, etc.) should exceed 10 GHz.
  - d) Set the oscilloscope to trigger externally with the vertical setting at 50 mV/div and the horizontal setting at 10 ns/div.
2. Turn on the AVO-9A-B-P2-P. The main menu will appear on the LCD.

3. To set the AVO-9A-B-P2-P to trigger from the internal clock at a PRF of 20 kHz:
  - a) The arrow pointer should be pointing at the frequency menu item. If it is not, press the MOVE button until it is.
  - b) Press the CHANGE button. The frequency submenu will appear. Rotate the ADJUST knob until the frequency is set at 20 kHz.
  - c) The arrow pointer should be pointing at the “Internal” choice. If it is not, press MOVE until it is.
  - d) Press CHANGE to return to the main menu.
4. To set the delay to 100 ns:
  - a) Press the MOVE button until the arrow pointer is pointing at the delay menu item.
  - b) Press the CHANGE button. The delay submenu will appear. Rotate the ADJUST knob until the delay is set at 100 ns.
  - c) The arrow pointer should be pointing at the “Normal” choice. If it is not, press MOVE until it is.
  - d) Press CHANGE to return to the main menu.
5. To set the pulse width to 4 ns:
  - a) Press the MOVE button until the arrow pointer is pointing at the pulse width menu item.
  - b) Press the CHANGE button. The pulse width submenu will appear. Rotate the ADJUST knob until the pulse width is set at 4 ns.
  - c) The arrow pointer should be pointing at the “Normal” choice. If it is not, press MOVE until it is.
  - d) Press CHANGE to return to the main menu.
6. At this point, nothing should appear on the oscilloscope.
7. To enable the output:
  - a) Press the MOVE button until the arrow pointer is pointing at the output menu item.
  - b) Press the CHANGE button. The output submenu will appear.

- c) Press MOVE until the arrow pointer is pointing at the “ON” choice.
  - d) Press CHANGE to return to the main menu.
8. To change the output amplitude:
- a) Press the MOVE button until the arrow pointer is pointing at the amplitude menu item.
  - b) Press the CHANGE button. The amplitude submenu will appear. Rotate the ADJUST knob until the amplitude is set at 10V.
  - c) Observe the oscilloscope. You should see 4 ns wide, 10V pulses. If you do not, you may need to adjust the delay setting to a value more compatible with your sampling oscilloscope. Repeat step 4 if required. You may also need to adjust the sampling scope controls.
  - d) Rotate the ADJUST knob. The amplitude as seen on the oscilloscope should vary. Return it to 10V.
  - e) Press CHANGE to return to the main menu.
9. Try varying the pulse width, by repeating step (5). As you rotate the ADJUST knob, the pulse width on the oscilloscope will change. It should agree with the displayed value.
10. Turn off the instrument, and connect the output module as shown in the following diagram. Insert an appropriate diode load into the output module socket. Repeat steps 2 to 9, and view the “MI” output on the sampling oscilloscope.

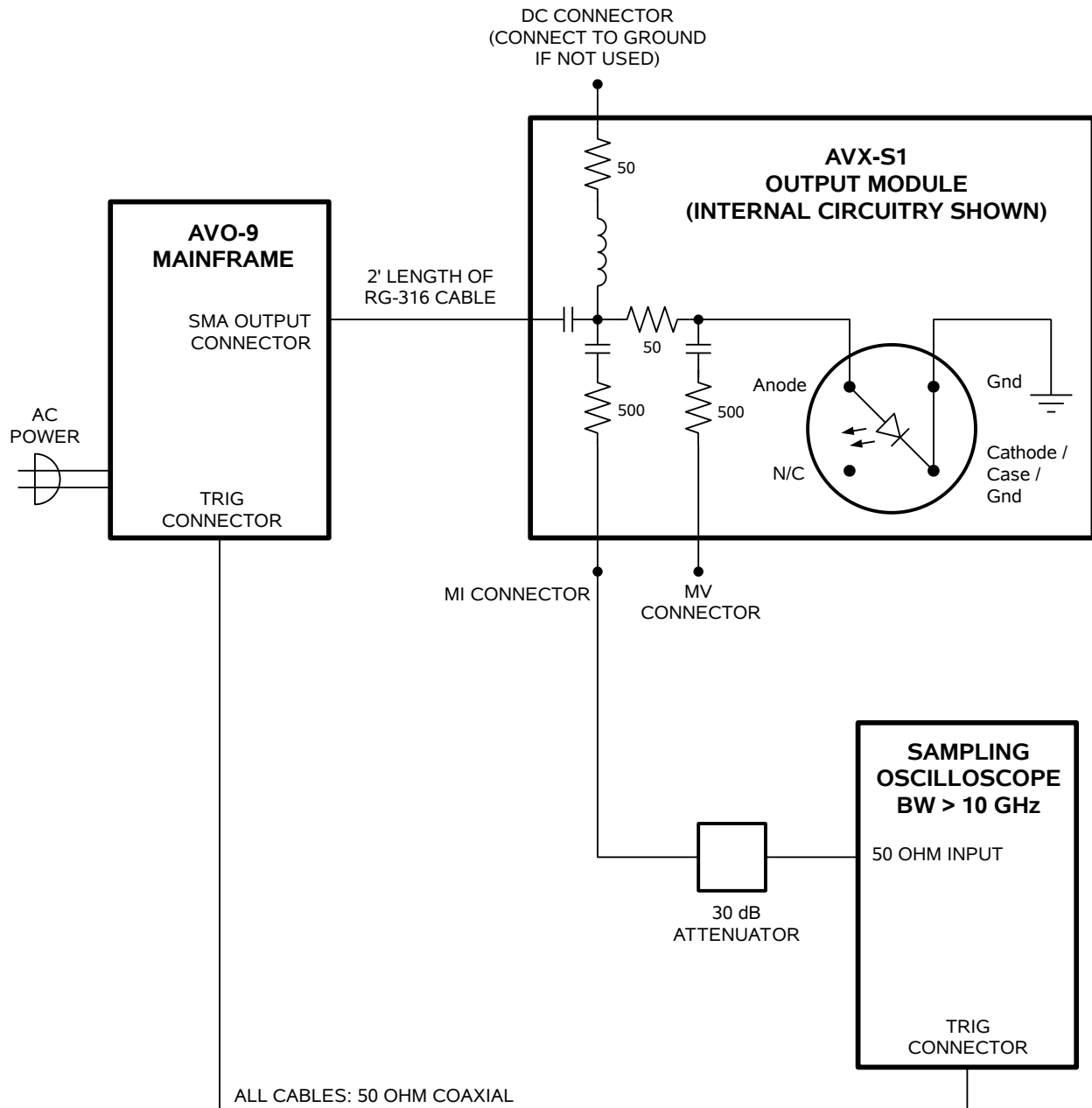

This completes the operational check.

## PROGRAMMING YOUR PULSE GENERATOR

### KEY PROGRAMMING COMMANDS

The “Programming Manual for -B Instruments” describes in detail how to connect the pulse generator to your computer, and the programming commands themselves. A large number of commands are available; however, normally you will only need a few of these. Here is a basic sample sequence of commands that might be sent to the instrument after power-up:

*rst	(resets the instrument)
trigger:source internal	(selects internal triggering)
frequency 1000 Hz	(sets the frequency to 1000 Hz)
pulse:width 4 ns	(sets the pulse width to 4 ns)
pulse:delay 20 ns	(sets the delay to 20 ns)
volt:ampl 10	(sets the amplitude to 10 V)
output on	(turns on the output)

For triggering a single event, this sequence would be more appropriate:

*rst	(resets the instrument)
trigger:source hold	(turns off all triggering)
pulse:width 4 ns	(sets the pulse width to 4 ns)
output on	(turns on the output)
volt:ampl 10	(sets the amplitude to 10 V)
trigger:source immediate	(generates a single non-repetitive trigger event)
trigger:source hold	(turns off all triggering)
output off	(turns off the output)

To set the instrument to trigger from an external TTL signal applied to the rear-panel TRIG connector, use:

*rst	(resets the instrument)
trigger:source external	(selects external triggering)
pulse:width 4 ns	(sets the pulse width to 4 ns)
pulse:delay 100 ns	(sets the delay to 100 ns)
volt:ampl 10	(sets the amplitude to 10 V)
output on	(turns on the output)

These commands will satisfy 90% of your programming needs.

## ALL PROGRAMMING COMMANDS

For more advanced programmers, a complete list of the available commands is given below. These commands are described in detail in the “Programming Manual for -B Instruments”. (Note: this manual also includes some commands that are not implemented in this instrument. They can be ignored.)

<u>Keyword</u>	<u>Parameter</u>	<u>Notes</u>
LOCAL		
OUTPut:		
:[STATe]	<boolean value>	
:PROTection		
:TRIPped?		[query only]
REMOTE		
[SOURce]:		
:FREQuency		
[:CW   FIXed]	<numeric value>	
[SOURce]:		
:PULSe		
:PERiod	<numeric value>	
:WIDTh	<numeric value>	
:DCYClE	<numeric value>	
:HOLD	WIDTh   DCYClE	
:DELay	<numeric value>	
:GATE		
:TYPE	ASYNc   SYNc	
:LEVel	HIgh   LOw	
[SOURce]:		
:VOLTage		
[:LEVel]		
[:IMMediate]		
[:AMPLitude]	<numeric value>	
:PROTection		
:TRIPped?		[query only]
STATUS:		
:OPERation		
:[EVENT]?		[query only, always returns "0"]
:CONDition?		[query only, always returns "0"]
:ENABle	<numeric value>	[implemented but not useful]
:QUEStionable		
:[EVENT]?		[query only, always returns "0"]
:CONDition?		[query only, always returns "0"]
:ENABle	<numeric value>	[implemented but not useful]
SYSTEM:		
:COMMunicate		
:GPIB		
:ADDReSS	<numeric value>	
:SERial		
:CONTRol		
:RTS	ON   IBFull   RFR	
:[RECeive]		
:BAUD	1200   2400   4800   9600	
:BITS	7   8	
:ECHO	<boolean value>	
:PARity		



	: [TYPE]	EVEN   ODD   NONE	
	: SBITS	1   2	
:ERRor			
:[NEXT]?			[query only]
:COUNT?			[query only]
:VERSion?			[query only]
TRIGger:			
:SOURce		INTernal   EXTernal   MANual   HOLD   IMMEDIATE	
*CLS			[no query form]
*ESE		<numeric value>	
*ESR?			[query only]
*IDN?			[query only]
*OPC			
*SAV		0   1   2   3	[no query form]
*RCL		0   1   2   3	[no query form]
*RST			[no query form]
*SRE		<numeric value>	
*STB?			[query only]
*TST?			[query only]
*WAI			[no query form]

## MECHANICAL INFORMATION

### TOP COVER REMOVAL

If necessary, the interior of the instrument may be accessed by removing the four Phillips screws on the top panel. With the four screws removed, the top cover may be slid back (and off).

 Always disconnect the power cord and allow the instrument to sit unpowered for 10 minutes before opening the instrument. This will allow any internal stored charge to discharge.

There are no user-adjustable internal circuits. For repairs other than fuse replacement, please contact Avtech (info@avtechpulse.com) to arrange for the instrument to be returned to the factory for repair. Service is to be performed solely by qualified service personnel.

 Caution: High voltages are present inside the instrument during normal operation. Do not operate the instrument with the cover removed.

### RACK MOUNTING

A rack mounting kit is available. The -R5 rack mount kit may be installed after first removing the one Phillips screw on the side panel adjacent to the front handle.

### ELECTROMAGNETIC INTERFERENCE

To prevent electromagnetic interference with other equipment, all used outputs should be connected to shielded loads using shielded coaxial cables. Unused outputs should be terminated with shielded coaxial terminators or with shielded coaxial dust caps, to prevent unintentional electromagnetic radiation. All cords and cables should be less than 3m in length.

## MAINTENANCE

### REGULAR MAINTENANCE

This instrument does not require any regular maintenance.

On occasion, one or more of the four rear-panel fuses may require replacement. All fuses can be accessed from the rear panel. See the “FUSES” section for details.

### CLEANING

If desired, the interior of the instrument may be cleaned using compressed air to dislodge any accumulated dust. (See the “TOP COVER REMOVAL” section for instructions on accessing the interior.) No other cleaning is recommended.

# WIRING DIAGRAMS

## WIRING OF AC POWER 1/2

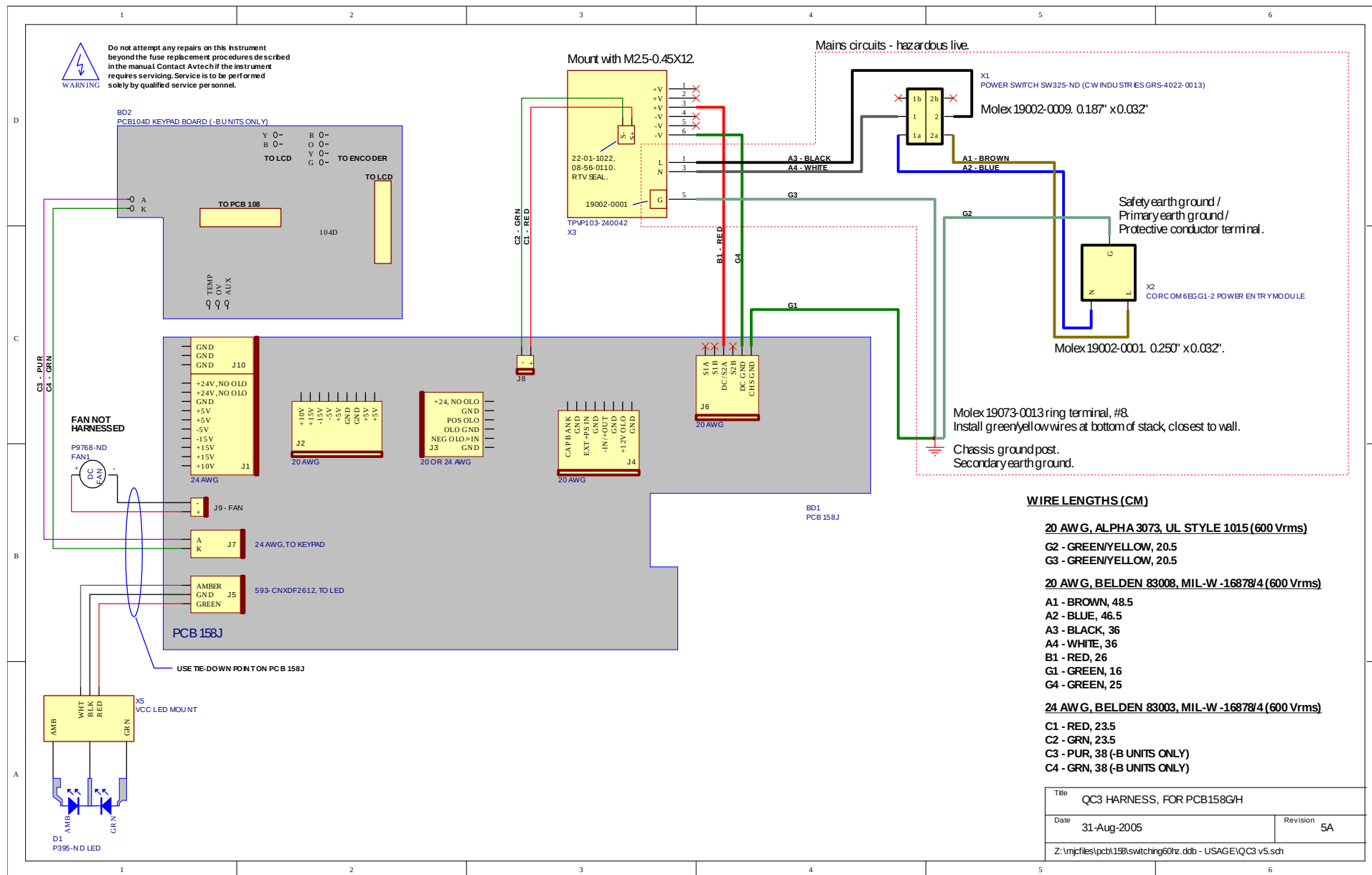

# WIRING OF AC POWER 2/2

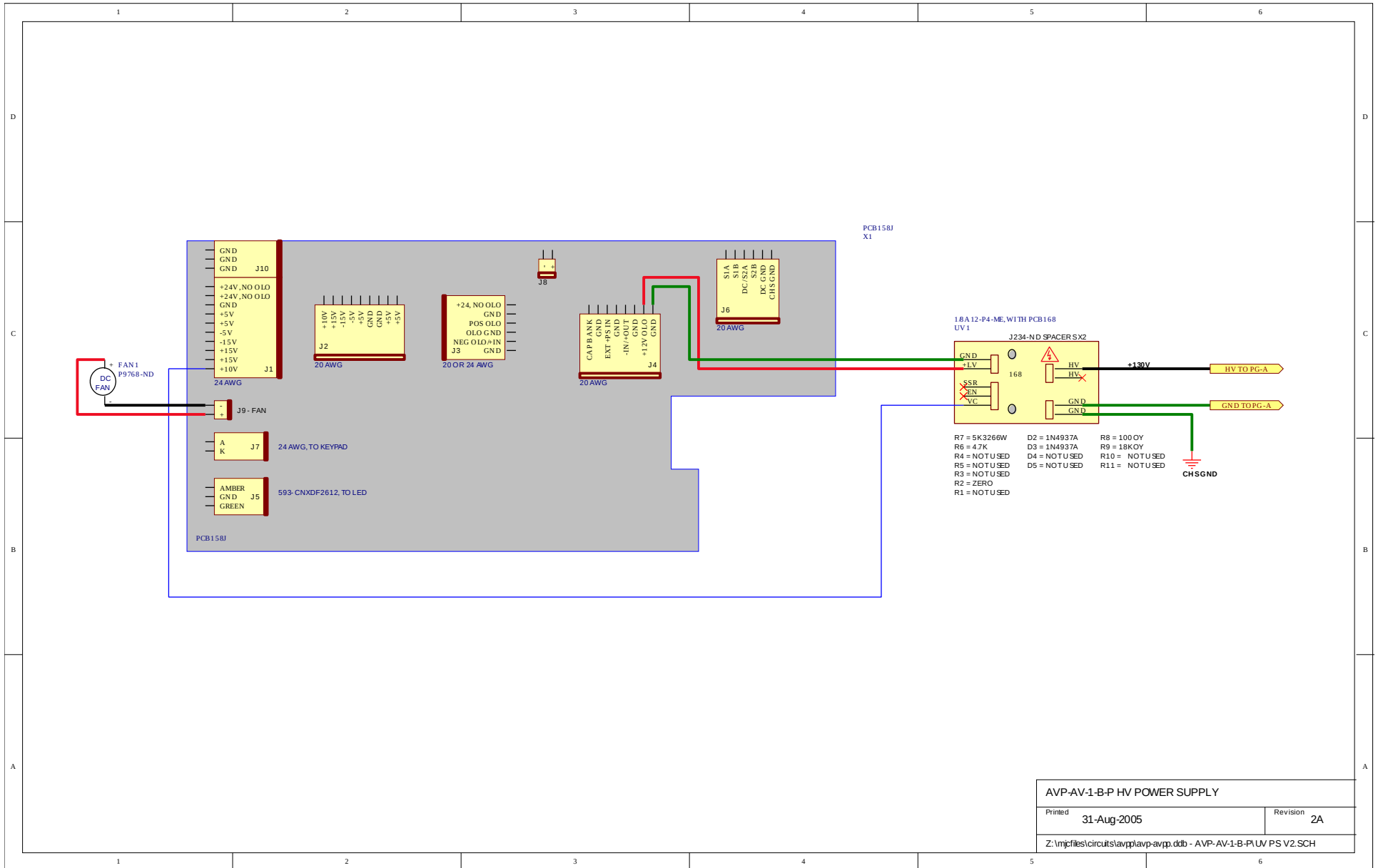

AVP-AV-1-B-P HV POWER SUPPLY		
Printed	31-Aug-2005	Revision 2A
Z:\mptfiles\circuits\avpp\avp-avpp.ddb - AVP-AV-1-B-PLUV PS V2.SCH		

# PCB 158J - LOW VOLTAGE POWER SUPPLY, 1/3

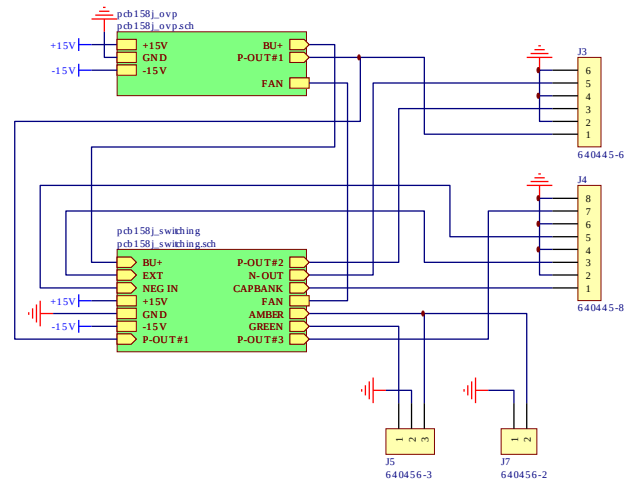

Title		LOW VOLTAGE DC/DC POWER SUPPLY
Date	31-Aug-2005	Revision
Z:\mjcfiles\pcb158\switching01rz.ddb - 158J.pcb158j.sch		







# PCB 168B - HIGH VOLTAGE DC POWER SUPPLY

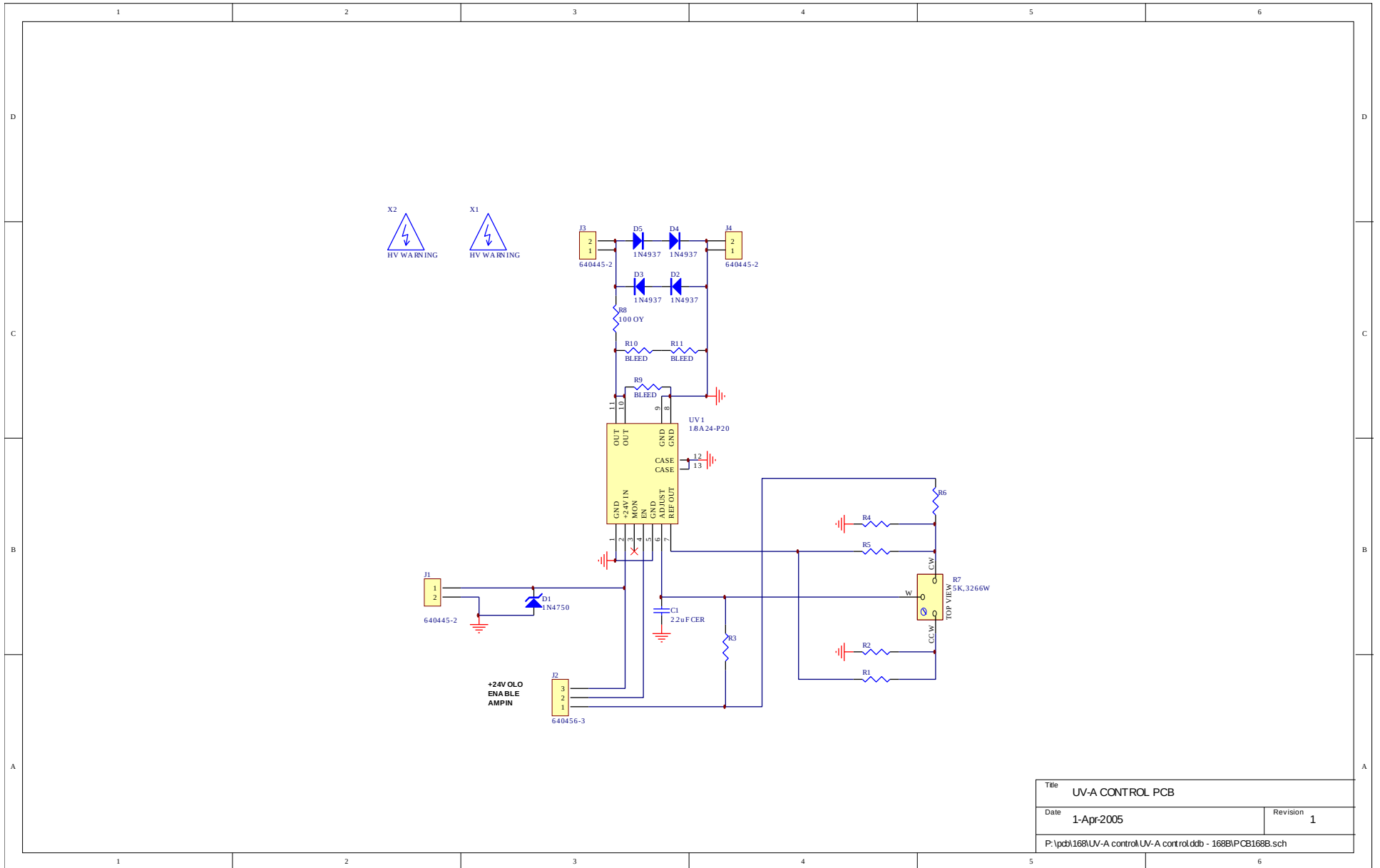

Title UV-A CONTROL PCB	
Date 1-Apr-2005	Revision 1
P:\pcb\168\UV-A control\UV-A control.dtb - 168B\PCB168B.sch	

# PCB 104D - KEYPAD / DISPLAY BOARD, 1/3

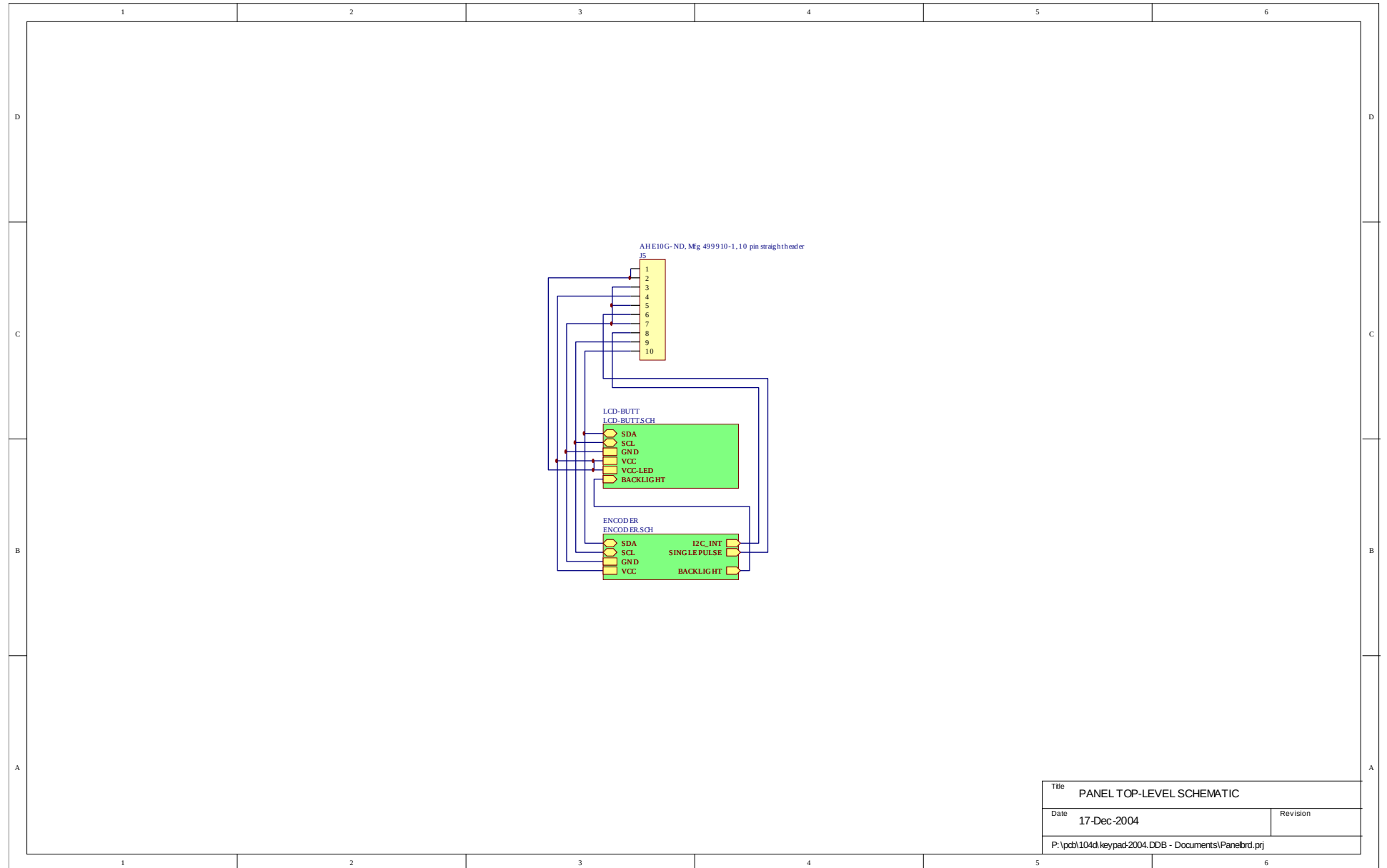

Title		PANEL TOP-LEVEL SCHEMATIC	
Date	17-Dec-2004	Revision	
P:\pcb\104d\keypad\2004.DDB - Documents\Panelbrd.prj			

# PCB 104D - KEYPAD / DISPLAY BOARD, 2/3

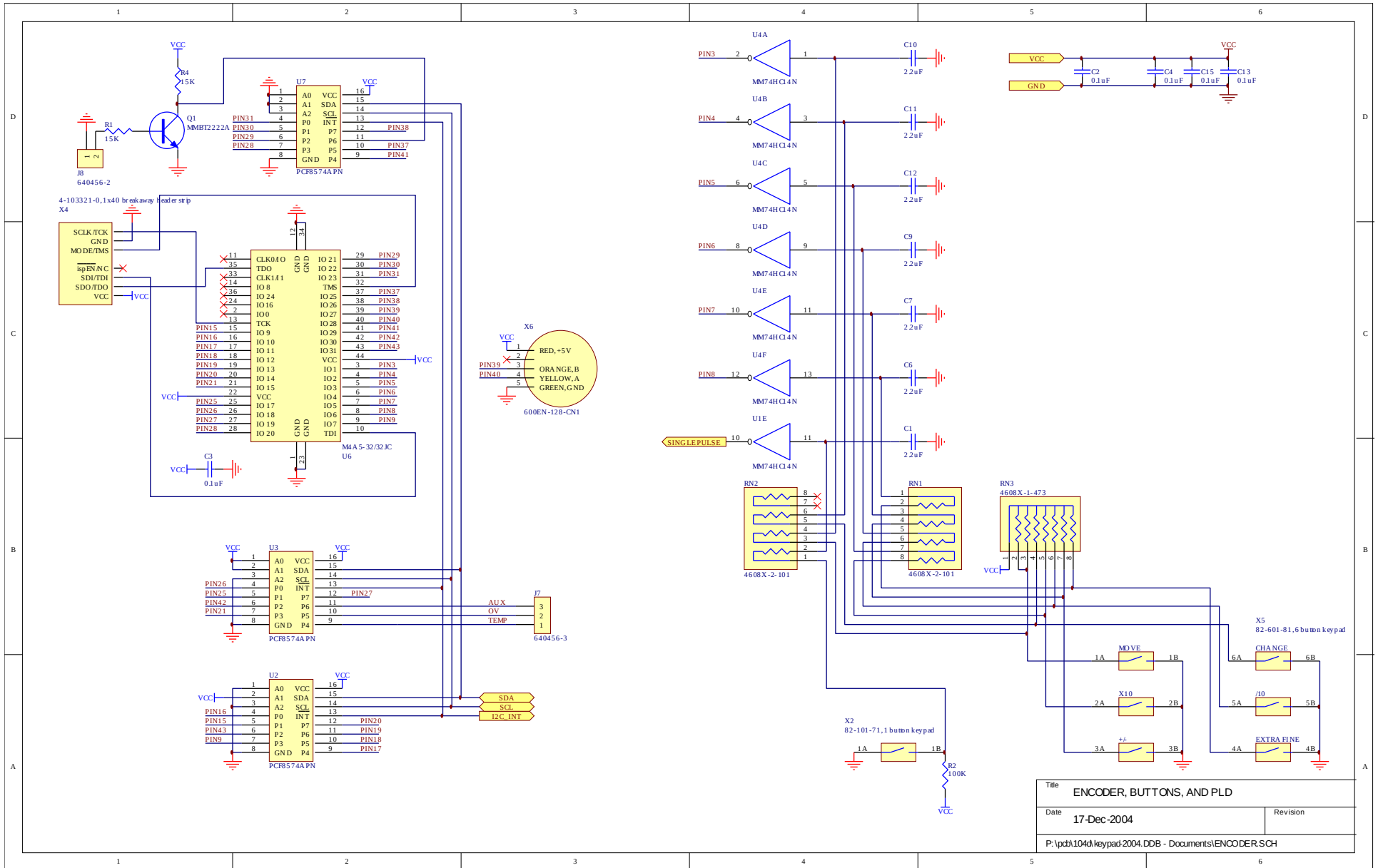

# PCB 104D - KEYPAD / DISPLAY BOARD, 3/3

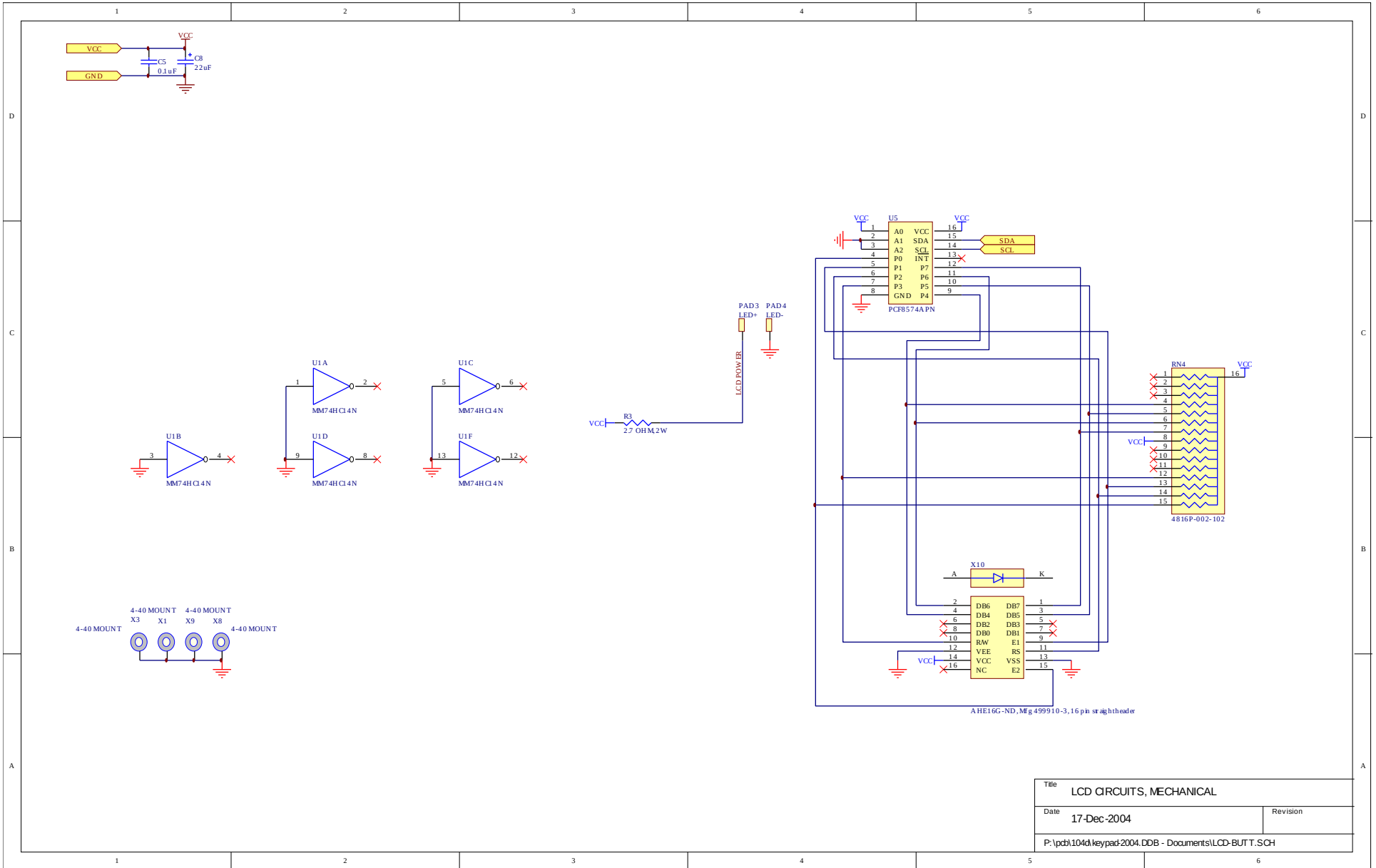

Title		LCD CIRCUITS, MECHANICAL	
Date	17-Dec-2004	Revision	
P:\pcb\104d\keypad\2004.DDB - Documents\LCD-BUTT.SCH			

# MAIN WIRING - POSITIVE UNITS

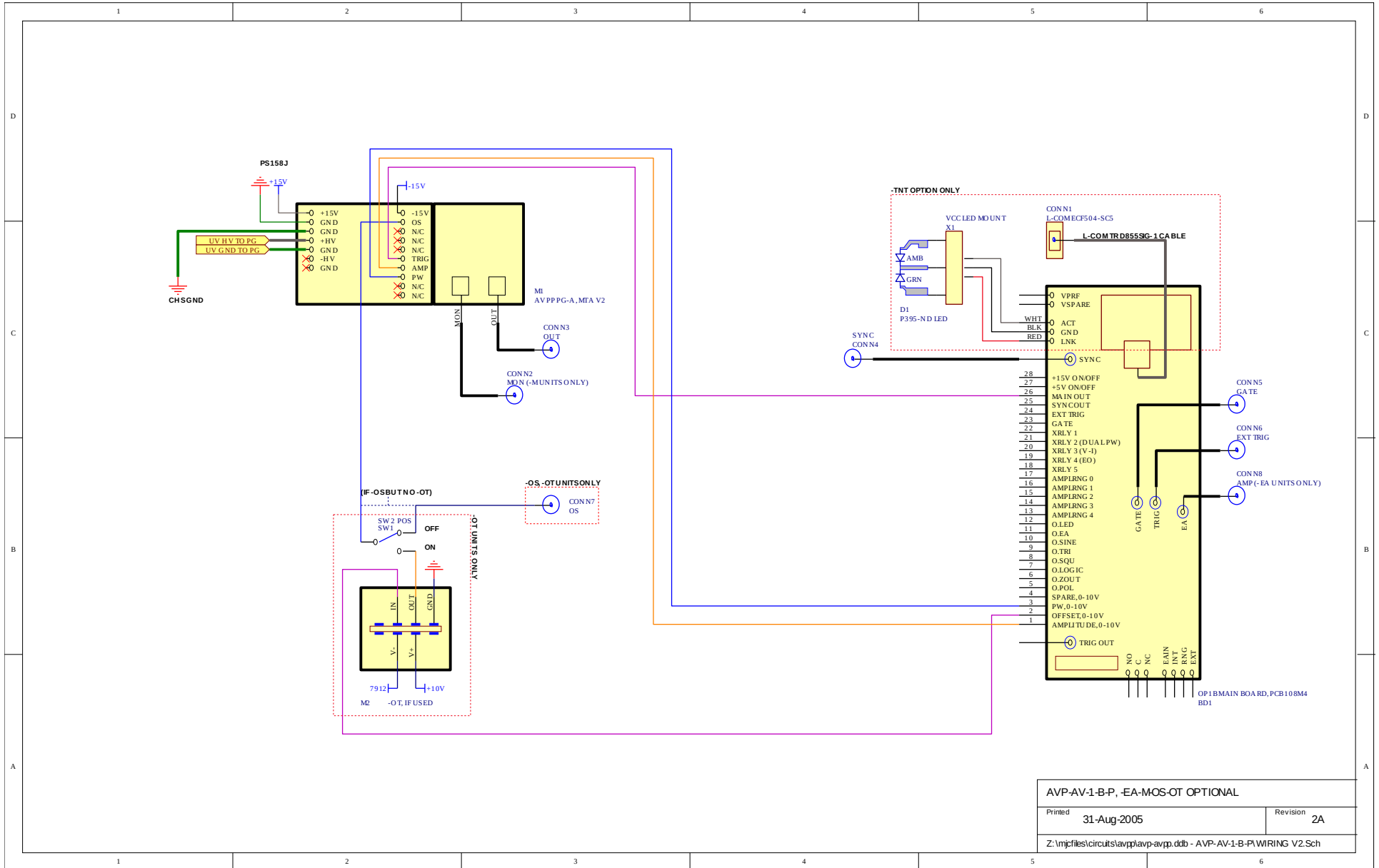

AVP-AV-1-B-P, -EA-MOS-OT OPTIONAL	
Printed	31-Aug-2005
Revision	2A
Z:\mptfiles\circuits\avpp\avp-avpp.ddb - AVP-AV-1-B-P WIRING V2.Sch	

PERFORMANCE CHECKSHEET