



AVTECH ELECTROSYSTEMS LTD.

NANOSECOND WAVEFORM ELECTRONICS
SINCE 1975

P.O. BOX 265
OGDENSBURG, NY
U.S.A. 13669-0265

TEL: 888-670-8729 (USA & Canada) or +1-613-226-5772 (Intl)
FAX: 800-561-1970 (USA & Canada) or +1-613-226-2802 (Intl)

info@avtechpulse.com - http://www.avtechpulse.com/

BOX 5120, LCD MERIVALE
OTTAWA, ONTARIO
CANADA K2C 3H4

INSTRUCTIONS

MODEL AVO-9C-C-P2-ADA-AK1-MD

0 TO 100 mA, 300 ps RISE TIME

HIGH PERFORMANCE LASER DIODE DRIVER

WITH PLUG-IN SOCKET OUTPUT MODULE

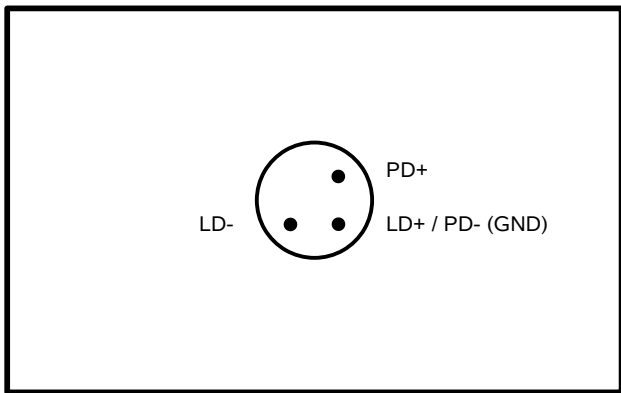

AVX-S1 OUTPUT MODULE, SOCKET VIEW

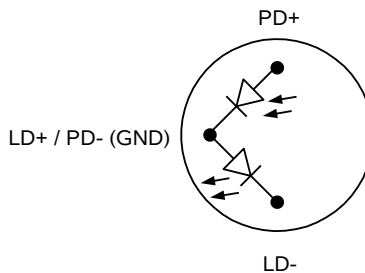

MATCHING USER-SUPPLIED
DIODE PACKAGE
(BOTTOM VIEW).
5.6 mm PACKAGE.

SERIAL NUMBER: _____

WARRANTY

Avtech Electrosystems Ltd. warrants products of its manufacture to be free from defects in material and workmanship under conditions of normal use. If, within one year after delivery to the original owner, and after prepaid return by the original owner, this Avtech product is found to be defective, Avtech shall at its option repair or replace said defective item. This warranty does not apply to units which have been disassembled, modified or subjected to conditions exceeding the applicable specifications or ratings. This warranty is the extent of the obligation assumed by Avtech with respect to this product and no other warranty or guarantee is either expressed or implied.

TECHNICAL SUPPORT

Phone: 888-670-8729 (USA & Canada) or +1-613-226-5772 (Intl)

Fax: 800-561-1970 (USA & Canada) or +1-613-226-2802 (Intl)

E-mail: info@avtechpulse.com

World Wide Web: <http://www.avtechpulse.com>

TABLE OF CONTENTS

WARRANTY.....	2
TECHNICAL SUPPORT.....	2
TABLE OF CONTENTS.....	3
INTRODUCTION.....	5
SPECIFICATIONS.....	6
EUROPEAN REGULATORY NOTES.....	7
EC DECLARATION OF CONFORMITY.....	7
DIRECTIVE 2002/95/EC (RoHS).....	7
DIRECTIVE 2002/96/EC (WEEE).....	7
INSTALLATION.....	9
VISUAL CHECK.....	9
POWER RATINGS.....	9
CONNECTION TO THE POWER SUPPLY.....	9
PROTECTION FROM ELECTRIC SHOCK.....	10
ENVIRONMENTAL CONDITIONS.....	10
FUSES.....	12
AC FUSE REPLACEMENT.....	12
DC FUSE REPLACEMENT.....	13
FUSE RATINGS.....	13
FRONT PANEL CONTROLS.....	14
REAR PANEL CONTROLS.....	16
GENERAL INFORMATION.....	17
MINIMAL TEST ARRANGEMENT - WITHOUT OUTPUT MODULE.....	17
NORMAL TEST ARRANGEMENT.....	18
AMPLITUDE CONTROL.....	20
BASIC PULSE CONTROL.....	20
PULSE WIDTH / AMPLITUDE INTERACTION.....	21
PROTECTING YOUR INSTRUMENT.....	22
DO NOT EXCEED 25 MHz.....	22
USE A 50Ω LOAD.....	22
INSTALL THE DIODE CORRECTLY.....	22
MECHANICAL INFORMATION.....	23
TOP COVER REMOVAL.....	23

RACK MOUNTING.....	23
ELECTROMAGNETIC INTERFERENCE.....	23
MAINTENANCE.....	24
REGULAR MAINTENANCE.....	24
CLEANING.....	24
WIRING DIAGRAMS.....	25
WIRING OF AC POWER.....	25
PCB 158K - LOW VOLTAGE POWER SUPPLY, 1/3.....	26
PCB 158K - LOW VOLTAGE POWER SUPPLY, 2/3.....	27
PCB 158K - LOW VOLTAGE POWER SUPPLY, 3/3.....	28
PCB 168B - HIGH VOLTAGE DC POWER SUPPLY.....	29
MAIN WIRING.....	30
PERFORMANCE CHECKSHEET.....	31

Manual Reference: /files/server1/officefiles/instructword/avo-9/AVO-9C-C-P2-ADA-AK1-MD,ed1.odt.
Last modified February 29, 2024.
Copyright © 2024 Avtech Electrosystems Ltd, All Rights Reserved.

INTRODUCTION

The AVO-9C-C-P2-ADA-AK1-MD is a high performance instrument capable of generating up to 100 mA of current into a laser diode load, at repetition rates up to 25 MHz. The pulse width is variable from 0.5 to 10 ns, and the rise and fall times are 300 ps or less.

The AVO-9C-C-P2-ADA-AK1-MD consists of a mainframe unit and an AVX-S1 series output module, which provides a socket into which the user's laser diode may be inserted. The mainframe generates voltage pulses of between 0 and -8V. The output module connects to the instrument mainframe via a detachable 2 foot long coaxial cable. The output module contains the necessary elements to match the laser diode to the pulse generator mainframe. A DC bias current of 0 to 100 mA may be applied to the laser diode by applying the desired DC current to a solder terminal on the output module. The output modules include an SMA output connector that provides an attenuated coincident replica of the diode current.

The AVX-S1 output module supplied with the AVO-9C-C-P2-ADA-AK1-MD is specifically designed to accommodate 3-pin 5.6mm diodes with the pinout illustrated below:

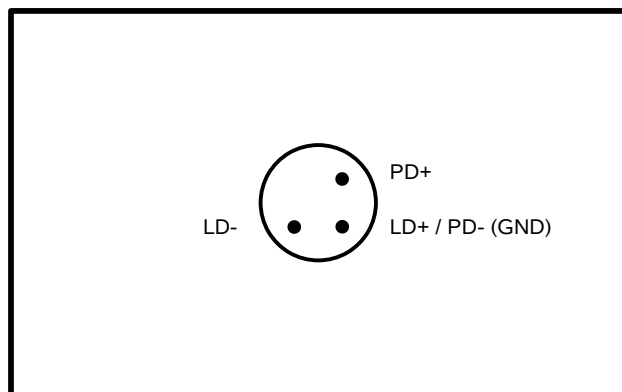

AVX-S1 OUTPUT MODULE, SOCKET VIEW

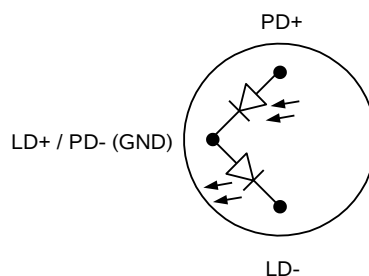

**MATCHING USER-SUPPLIED
DIODE PACKAGE
(BOTTOM VIEW).
5.6 mm PACKAGE.**

This instrument is intended for use in research, development, test and calibration laboratories by qualified personnel.

SPECIFICATIONS

Model:	AVO-9C-C ¹
Amplitude ^{3,8} :	0 - 100 mA
Max. output of mainframe into 50Ω (V _{MAINFRAME}):	8V
R _S + R _{DIODE} :	50Ω
Transformer ratio, N:	1
Allowed load voltage range:	0 to 3V
Pulse width (FWHM) ⁹ :	0.5 - 10 ns
Duty cycle limits:	N/A
Minimum PRF:	10 kHz
Maximum PRF:	25 MHz
Rise / fall times (20%-80%):	≤ 300 ps
Related 50Ω series:	AVMM-2
Included output module:	AVX-S1
Polarity ⁵ :	Negative
Propagation delay:	≤ 100 ns
Jitter:	± 15 ps
DC offset or bias insertion:	Apply required DC bias current in the range of ± 100 mA to solder terminal on output module.
Sync delay:	Variable 0 to 200 ns (Sync out to pulse out)
Sync output (to 50Ω):	+0.5V, 20 ns
Trigger required: (ext trig mode)	+ 5 V (TTL) ≥ 10 ns
Monitor output option ⁷ :	Provides connection to output of photo diode detector.
Connectors: Out:	User-specified socket.
Other:	Trig, Sync: BNC, Monitor: SMA
Recommended accessory kit:	Add the suffix "-AK1" to the model number to include the recommended accessory kit. Consists of three SMA, 18 GHz, 2 Watt attenuators (10, 20 & 30 dB) for use on the output, and two 50 Ohm, 1 GHz, 1 Watt feed-through terminators (one SMA, one BNC) for use on external trigger inputs.
Power requirements:	100 - 240 Volts, 50 - 60 Hz
Dimensions, Mainframe: (H×W×D)	100 x 215 x 375 mm (3.9" x 8.5" x 14.8").
Dimensions, Output Module:	41 x 66 x 76 mm (1.6" x 2.6" x 3.0"), cast aluminum, blue enamel
Temperature range:	+5°C to +40°C

- 1) -C suffix indicates stand-alone lab instrument with internal clock and line powering. (See <http://www.avtechpulse.com/formats/> for details of the instrument formats).
- 2) -B suffix indicates IEEE-488.2 GPIB and RS-232 control of amplitude and frequency. See <http://www.avtechpulse.com/gpib/> for details.
- 3) For operation at amplitudes of less than 20% of full-scale, best results will be obtained by setting the amplitude near full-scale and using external attenuators on the output, between the mainframe and the output module. Attenuators are available in the -AK1 accessory kit option.
- 4) Add suffix -HC to the model number to specify current-doubling option.
- 5) Indicate desired polarity by suffixing model number with -P or -N.
- 6) Add the suffix -TNT to the model number to specify the Telnet / Web Ethernet control option.
- 7) For photo diode output monitor option add suffix -MD.
- 8) Standard AVO-9A-C, AVO-9B-C, and AVO-9E-C units have a one-turn amplitude dial. To specify a ten-turn amplitude dial, suffix the model number with -AT. Not applicable for -B units.
- 9) Standard AVO-9A-C, AVO-9B-C, and AVO-9E-C units have a one-turn pulse width dial. To specify a ten-turn pulse width dial, suffix the model number with -PWT. Not applicable for -B units.

EUROPEAN REGULATORY NOTES

EC DECLARATION OF CONFORMITY

We Avtech Electrosystems Ltd.
P.O. Box 5120, LCD Merivale
Ottawa, Ontario
Canada K2C 3H4

declare that this pulse generator meets the intent of Directive 89/336/EEC for Electromagnetic Compatibility. Compliance pertains to the following specifications as listed in the official Journal of the European Communities:

EN 50081-1 Emission

EN 50082-1 Immunity

and that this pulse generator meets the intent of the Low Voltage Directive 72/23/EEC as amended by 93/68/EEC. Compliance pertains to the following specifications as listed in the official Journal of the European Communities:

EN 61010-1:2001 Safety requirements for electrical equipment for measurement, control, and laboratory use



DIRECTIVE 2002/95/EC (RoHS)

This instrument is exempt from Directive 2002/95/EC of the European Parliament and of the Council of 27 January 2003 on the Restriction of the use of certain Hazardous Substances (RoHS) in electrical and electronic equipment. Specifically, Avtech instruments are considered "Monitoring and control instruments" (Category 9) as defined in Annex 1A of Directive 2002/96/EC. The Directive 2002/95/EC only applies to Directive 2002/96/EC categories 1-7 and 10, as stated in the "Article 2 - Scope" section of Directive 2002/95/EC.

DIRECTIVE 2002/96/EC (WEEE)

European customers who have purchased this equipment directly from Avtech will have completed a "WEEE Responsibility Agreement" form, accepting responsibility for WEEE

compliance (as mandated in Directive 2002/96/EC of the European Union and local laws) on behalf of the customer, as provided for under Article 9 of Directive 2002/96/EC.

Customers who have purchased Avtech equipment through local representatives should consult with the representative to determine who has responsibility for WEEE compliance. Normally, such responsibilities will lie with the representative, unless other arrangements (under Article 9) have been made.

Requirements for WEEE compliance may include registration of products with local governments, reporting of recycling activities to local governments, and financing of recycling activities.



INSTALLATION

VISUAL CHECK

After unpacking the instrument mainframe and the transformer module, examine to ensure that they have not been damaged in shipment. Visually inspect all connectors, knobs, and handles. Confirm that a power cord and an instrumentation manual (this manual), are with the instrument. If the instrument has been damaged, file a claim immediately with the company that transported the instrument.

POWER RATINGS

This instrument is intended to operate from 100 - 240 V, 50 - 60 Hz.

The maximum power consumption is 57 Watts. Please see the “FUSES” section for information about the appropriate AC and DC fuses.

This instrument is an “Installation Category II” instrument, intended for operation from a normal single-phase supply.

CONNECTION TO THE POWER SUPPLY

An IEC-320 three-pronged recessed male socket is provided on the back panel for AC power connection to the instrument. One end of the detachable power cord that is supplied with the instrument plugs into this socket. The other end of the detachable power cord plugs into the local mains supply. Use only the cable supplied with the instrument. The mains supply must be earthed, and the cord used to connect the instrument to the mains supply must provide an earth connection. (The supplied cord does this.)

 Warning: Failure to use a grounded outlet may result in injury or death due to electric shock. This product uses a power cord with a ground connection. It must be connected to a properly grounded outlet. The instrument chassis is connected to the ground wire in the power cord.

The table below describes the power cord that is normally supplied with this instrument, depending on the destination region:

Destination Region	Description	Manufacturer	Part Number
Continental Europe	European CEE 7/7 "Schuko" 230V, 50Hz	Volex (http://www.volex.com)	17850-C3-326
		Qualtek (http://www.qualtekusa.com)	319004-T01
United Kingdom	BS 1363, 230V, 50Hz	Qualtek (http://www.qualtekusa.com)	370001-E01
Switzerland	SEV 1011, 2 30V, 50Hz	Volex (http://www.volex.com)	2102H-C3-10
Israel	SI 32, 220V, 50Hz	Volex (http://www.volex.com)	2115H-C3-10
North America, and all other areas	NEMA 5-15, 120V, 60 Hz	Qualtek (http://www.qualtekusa.com)	312007-01

PROTECTION FROM ELECTRIC SHOCK

 Operators of this instrument must be protected from electric shock at all times. The owner must ensure that operators are prevented access and/or are insulated from every connection point. In some cases, connections must be exposed to potential human contact. Operators must be trained to protect themselves from the risk of electric shock. This instrument is intended for use by qualified personnel who recognize shock hazards and are familiar with safety precautions required to avoid possibly injury. In particular, operators should:

1. Keep exposed high-voltage wiring to an absolute minimum.
2. Wherever possible, use shielded connectors and cabling.
3. Connect and disconnect loads and cables only when the instrument is turned off.
4. Keep in mind that all cables, connectors, oscilloscope probes, and loads must have an appropriate voltage rating.
5. Do not attempt any repairs on the instrument, beyond the fuse replacement procedures described in this manual. Contact Avtech technical support (see page 2 for contact information) if the instrument requires servicing. Service is to be performed solely by qualified service personnel.

ENVIRONMENTAL CONDITIONS

This instrument is intended for use under the following conditions:

1. indoor use;
2. altitude up to 2 000 m;
3. temperature 5 °C to 40 °C;

4. maximum relative humidity 80 % for temperatures up to 31 °C decreasing linearly to 50 % relative humidity at 40 °C;
5. Mains supply voltage fluctuations up to ± 10 % of the nominal voltage;
6. no pollution or only dry, non-conductive pollution.

FUSES

This instrument contains four fuses. All are accessible from the rear-panel. Two protect the AC prime power input, and two protect the internal DC power supplies. The locations of the fuses on the rear panel are shown in the figure below:

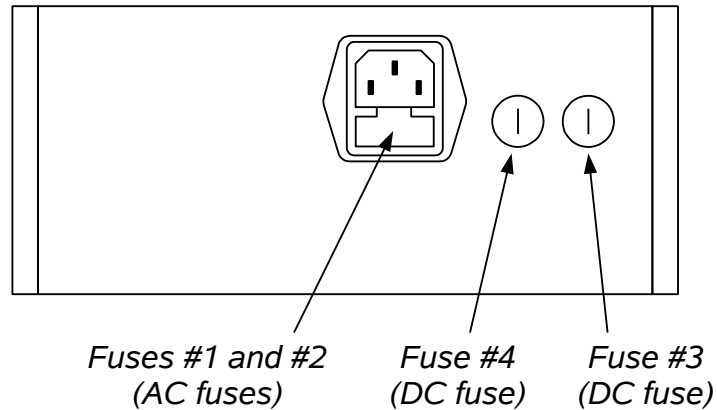

AC FUSE REPLACEMENT

To physically access the AC fuses, the power cord must be detached from the rear panel of the instrument. The fuse drawer may then be extracted using a small flat-head screwdriver, as shown below:

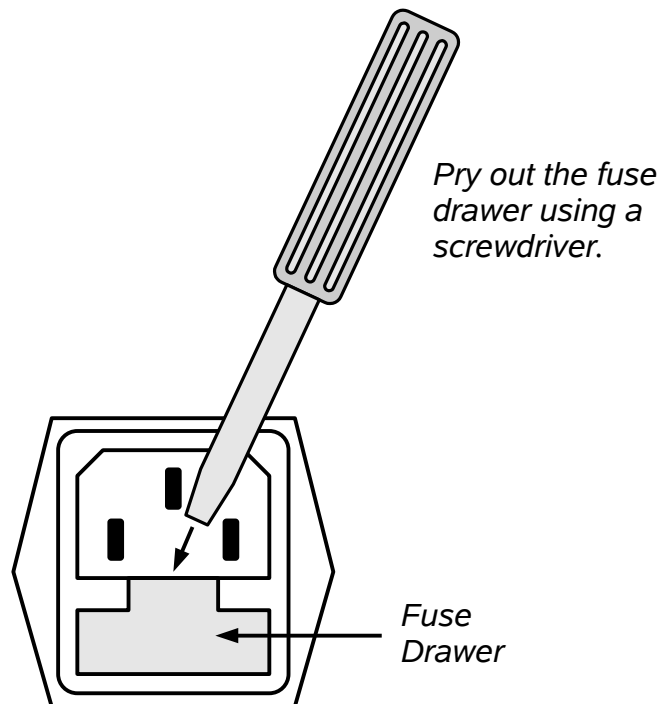

DC FUSE REPLACEMENT

The DC fuses may be replaced by inserting the tip of a flat-head screwdriver into the fuse holder slot, and rotating the slot counter-clockwise. The fuse and its carrier will then pop out.

FUSE RATINGS

The following table lists the required fuses:

Fuses	Nominal Mains Voltage	Rating	Case Size	Recommended Replacement Part	
				Littelfuse Part Number	Digi-Key Stock Number
#1, #2 (AC)	100-240V	0.5A, 250V, Time-Delay	5×20 mm	0218.500HXP	F2416-ND
#3 (DC)	N/A	0.8A, 250V, Time-Delay	5×20 mm	0218.800HXP	F2418-ND
#4 (DC)	N/A	0.5A, 250V, Time-Delay	5×20 mm	0218.500HXP	F2416-ND

The recommended fuse manufacturer is Littelfuse (<http://www.littelfuse.com>).

Replacement fuses may be easily obtained from Digi-Key (<http://www.digikey.com>) and other distributors.

FRONT PANEL CONTROLS

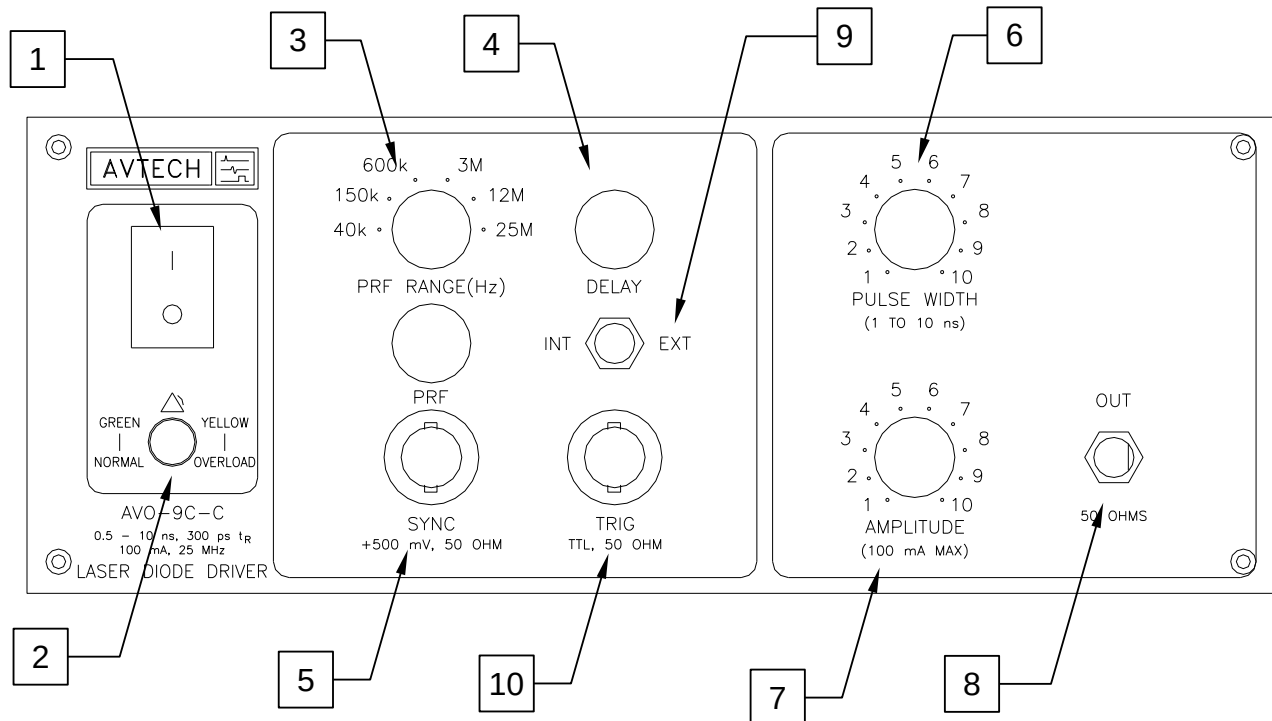

1. **POWER Switch.** This is the main power switch. When turning the instrument on, there may be a delay of several seconds before the instrument appears to respond.
2. **OVERLOAD Indicator.** When the instrument is powered, this indicator is normally green, indicating normal operation. If this indicator is yellow, an internal automatic overload protection circuit has been tripped. If the unit is overloaded (by operating at an exceedingly high duty cycle or by operating into a very low impedance), the protective circuit will disable the output of the instrument and turn the indicator light yellow. The light will stay yellow (i.e. output disabled) for about 5 seconds after which the instrument will attempt to re-enable the output (i.e. light green) for about 1 second. If the overload condition persists, the output will be disabled again (i.e. light yellow) for another 5 seconds. If the overload condition has been removed, the instrument will resume normal operation.

This overload indicator may flash yellow briefly at start-up. This is not a cause for concern.

3. **PRF Range Switch and Vernier.** This switch sets the pulse repetition frequency (PRF) range of the internal oscillator. The internal oscillator triggers the instrument when the INT/EXT switch is in the "INT" position. The marked value of each position is the upper limit range, approximately. The vernier dial directly below the switch varies the PRF within the set range.

4. DELAY Control. Controls the relative delay between the reference output pulse provided at the SYNC output (5) and the main output (8). This delay is variable over the range of 0 to 200 ns, approximately.
5. SYNC Output. This output precedes the main output (8) and is used to trigger the sampling scope time base. The output is a 500 mV, 20 ns (approx) pulse capable of driving a 50 Ohm load.
6. Pulse Width Control. This dial controls the pulse width.
7. Amplitude Control. This dial controls the pulse amplitude.
8. OUT Connector. This SMA connector is connected to the output module, when the output module is used to drive a diode load. If the output module is not used, this output will generate up to -8V into a load impedances of 50Ω , or 50Ω in series with a diode.
9. EXT-INT Control. With this toggle switch in the INT position, the PRF of the unit is controlled via an internal clock, which in turn is controlled by the PRF controls. With the toggle switch in the EXT position, the AVM unit requires a 15 ns (or wider) TTL level pulse applied at the TRIG input in order to trigger the output stages. In addition, in this mode, the scope time base must be triggered by the external trigger source.
10. TRIG Input. The external trigger signal is applied at this input when the EXT-INT toggle switch is in the EXT position.

REAR PANEL CONTROLS

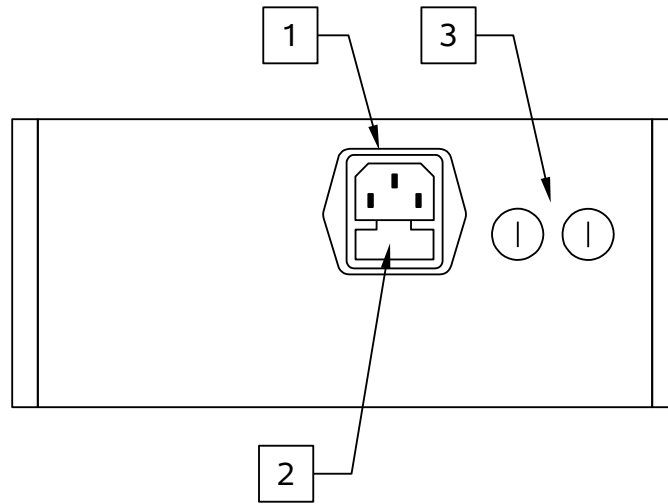

1. AC POWER INPUT. An IEC-320 C14 three-pronged recessed male socket is provided on the back panel for AC power connection to the instrument. One end of the detachable power cord that is supplied with the instrument plugs into this socket.
2. AC FUSE DRAWER. The two fuses that protect the AC input are located in this drawer. Please see the “FUSES” section of this manual for more information.
3. DC FUSES. These two fuses protect the internal DC power supplies. Please see the “FUSES” sections of this manual for more information.

GENERAL INFORMATION

MINIMAL TEST ARRANGEMENT - WITHOUT OUTPUT MODULE

The AVO-9C-C-P2-ADA-AK1-MD can be tested initially without the supplied output module. If the output module is not used, the mainframe output generates 0 to -8V into a 50 Ohm load, as illustrated below:

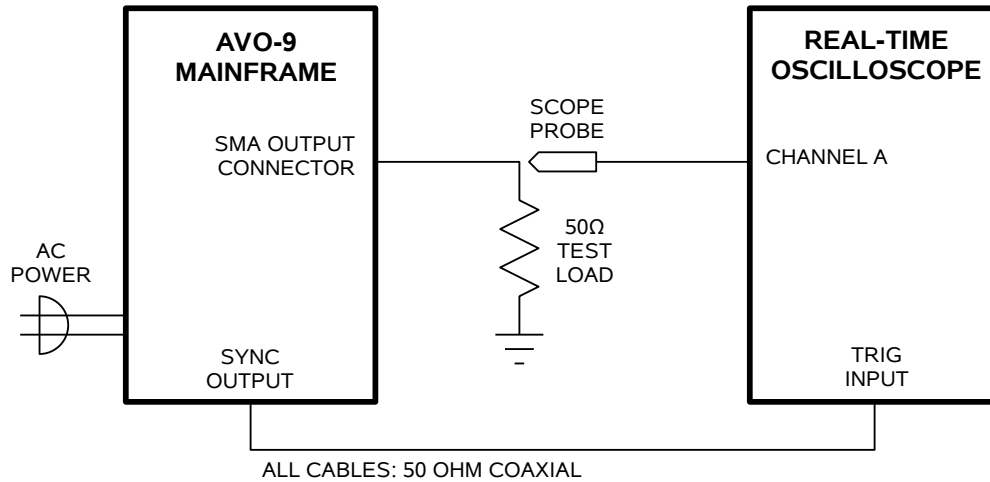

Since the AVO-9C-C-P2-ADA-AK1-MD can generate pulses with rise times as low as 300 ps, it may be necessary to use a sampling oscilloscope, rather than a real-time oscilloscope. In this case, the test arrangement should be altered as shown below:

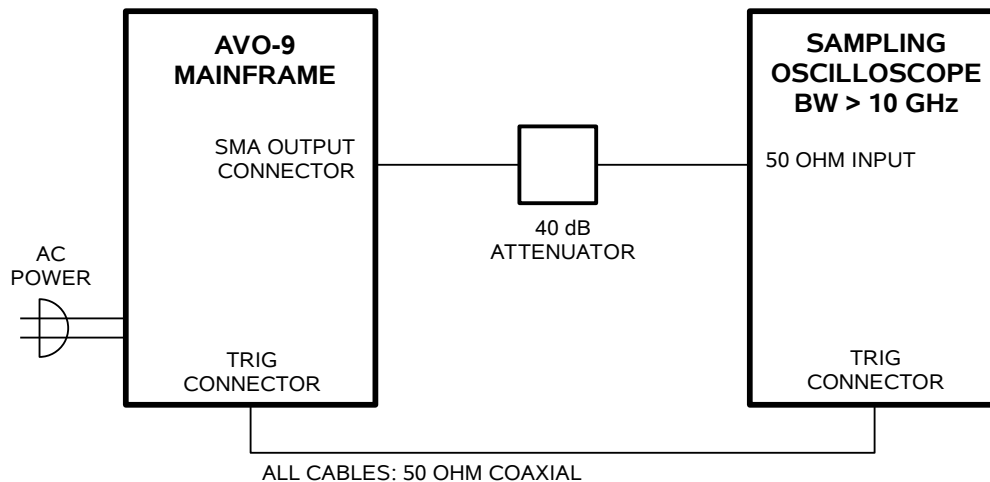

Since most sampling oscilloscopes have limited input amplitude ranges, attenuators are required. Suitable terminators are included in the optional -AK1 accessory kit.

When the output module is not used, a 50 Ohm load impedance is *required* for proper test operation.

NORMAL TEST ARRANGEMENT

To fully test the instrument, and for normal operation, the output module must be connected as shown below:

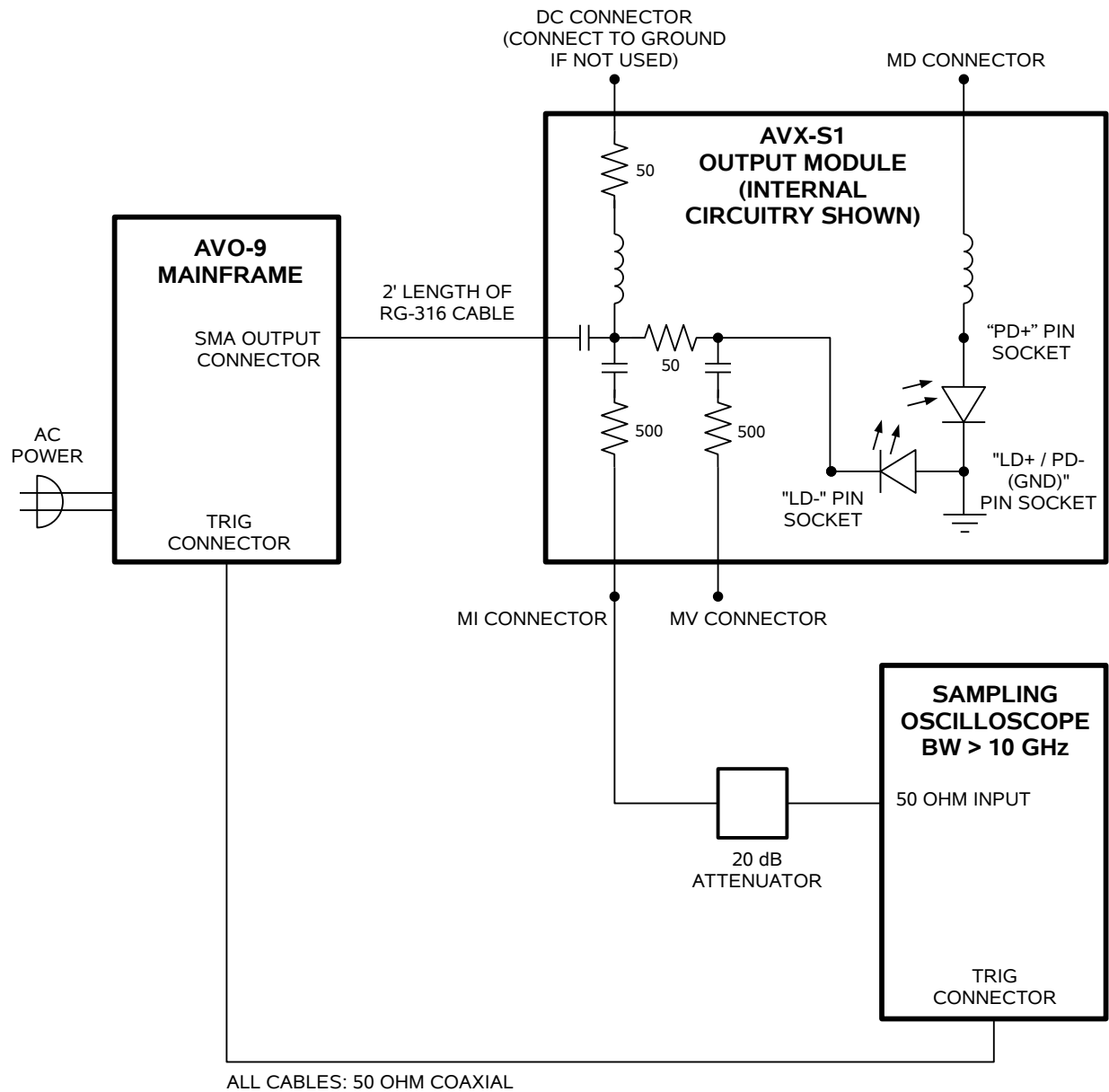

The diode load is inserted into the socket on the output module. The AVX-S1 output module supplied with the AVO-9C-C-P2-ADA-AK1-MD is specifically designed to accommodate 3-pin 5.6mm diodes with the pinout illustrated below:

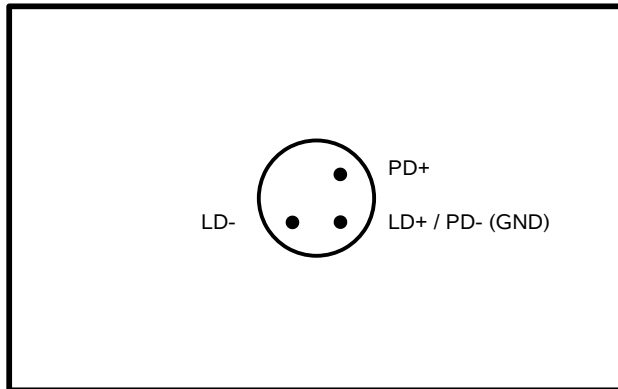

AVX-S1 OUTPUT MODULE, SOCKET VIEW

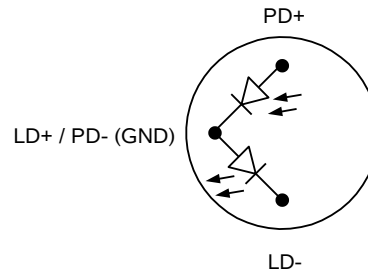

MATCHING USER-SUPPLIED
DIODE PACKAGE
(BOTTOM VIEW).
5.6 mm PACKAGE.

NOTE: Trim the diode leads to **no longer than 1.0 cm in length**. If the leads are longer than that, they may cause an internal short circuit in the output module, which may cause damage to the diode and the output module.

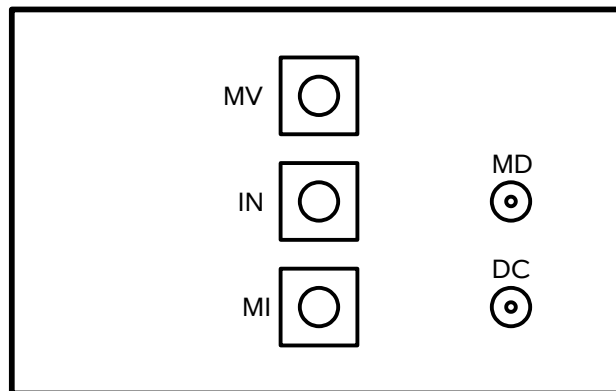

AVX-S1 OUTPUT MODULE, CONNECTOR VIEW

An oscilloscope may be used to monitor the MI and MD outputs, the locations of which are shown in the figure above. A forward DC bias may be applied to the laser diode by connecting a DC potential of 0 to -10 Volts to the DC solder terminal. The application of a small forward bias often yields a more ideal diode current waveform (as observed on the MI port). **Note that the DC port must be shorted to ground if a bias is not applied.**

The MD output is filtered, and is only useful for observing DC conditions.

AMPLITUDE CONTROL

When using the output module, the pulse current through the diode load is given by:

$$I_{\text{DIODE}} = (V_{\text{SET}} - V_{\text{DIODE}}) / (50\Omega + R_{\text{DIODE}})$$

where V_{SET} is the amplitude setting on the mainframe (between 0 and -8V), V_{DIODE} is the forward voltage drop across the diode (typically -2 to -3V), and R_{DIODE} is the resistor internal to the laser diode (normally approximately 0Ω). The 50Ω resistance is built into the AVX-S1 output module.

The AVO-9C-C-P2-ADA-AK1-MD can deliver up to 8V into a total resistance (diode resistance + output module resistance) of 50 Ohms. This means that if your diode voltage is 3V, then you can obtain up to $(8V - 3V) / 50 \text{ Ohms} = 100 \text{ mA}$ of current, approximately.

BASIC PULSE CONTROL

This instrument can be triggered by its own internal clock or by an external TTL trigger signal. When triggered internally, two mainframe output channels respond to the trigger: OUT and SYNC.

- OUT. This is the main output. The maximum output voltage is 8V.
- TRIG. The TRIG pulse is a fixed-width TTL-level reference pulse used to trigger oscilloscopes or other measurement systems.

These pulses are illustrated below:

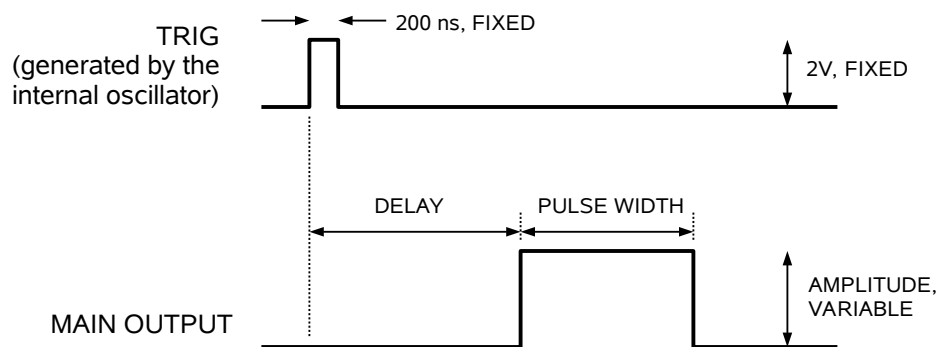

Figure A

When triggered externally, the TRIG connector acts as an input. The delay controls do not function in this mode.

PULSE WIDTH / AMPLITUDE INTERACTION

The pulse width and delay of the output pulse may vary slightly with the amplitude setting, particularly at lower amplitudes. For some demanding applications, it may be desirable to use external attenuators in conjunction with the AVO-9C-C-P2-ADA-AK1-MD, instead of generating a low-amplitude pulse directly.

A selection of suitable terminators are included in the optional -AK1 accessory kit.

PROTECTING YOUR INSTRUMENT

DO NOT EXCEED 25 MHz

The output stage may be damaged if triggered by an external signal at a pulse repetition frequency greater than 25 MHz.

USE A 50Ω LOAD

The mainframe output stage may be damaged if the output is not terminated into the output module or a 50Ω dummy load.

INSTALL THE DIODE CORRECTLY

NOTE: Trim the diode leads to **no longer than 1.0 cm in length**. If the leads are longer than that, they may cause an internal short circuit in the output module, which may cause damage to the diode and the output module.

MECHANICAL INFORMATION

TOP COVER REMOVAL

If necessary, the interior of the instrument may be accessed by removing the four Phillips screws on the top panel. With the four screws removed, the top cover may be slid back (and off).

 Always disconnect the power cord and allow the instrument to sit unpowered for 10 minutes before opening the instrument. This will allow any internal stored charge to discharge.

There are no user-adjustable internal circuits. For repairs other than fuse replacement, please contact Avtech (info@avtechpulse.com) to arrange for the instrument to be returned to the factory for repair. Service is to be performed solely by qualified service personnel.

 Caution: High voltages are present inside the instrument during normal operation. Do not operate the instrument with the cover removed.

RACK MOUNTING

A rack mounting kit is available. The -R5 rack mount kit may be installed after first removing the one Phillips screw on the side panel adjacent to the front handle.

ELECTROMAGNETIC INTERFERENCE

To prevent electromagnetic interference with other equipment, all used outputs should be connected to shielded loads using shielded coaxial cables. Unused outputs should be terminated with shielded coaxial terminators or with shielded coaxial dust caps, to prevent unintentional electromagnetic radiation. All cords and cables should be less than 3m in length.

MAINTENANCE

REGULAR MAINTENANCE

This instrument does not require any regular maintenance.

On occasion, one or more of the four rear-panel fuses may require replacement. All fuses can be accessed from the rear panel. See the “FUSES” section for details.

CLEANING

If desired, the interior of the instrument may be cleaned using compressed air to dislodge any accumulated dust. (See the “TOP COVER REMOVAL” section for instructions on accessing the interior.) No other cleaning is recommended.

WIRING DIAGRAMS

WIRING OF AC POWER

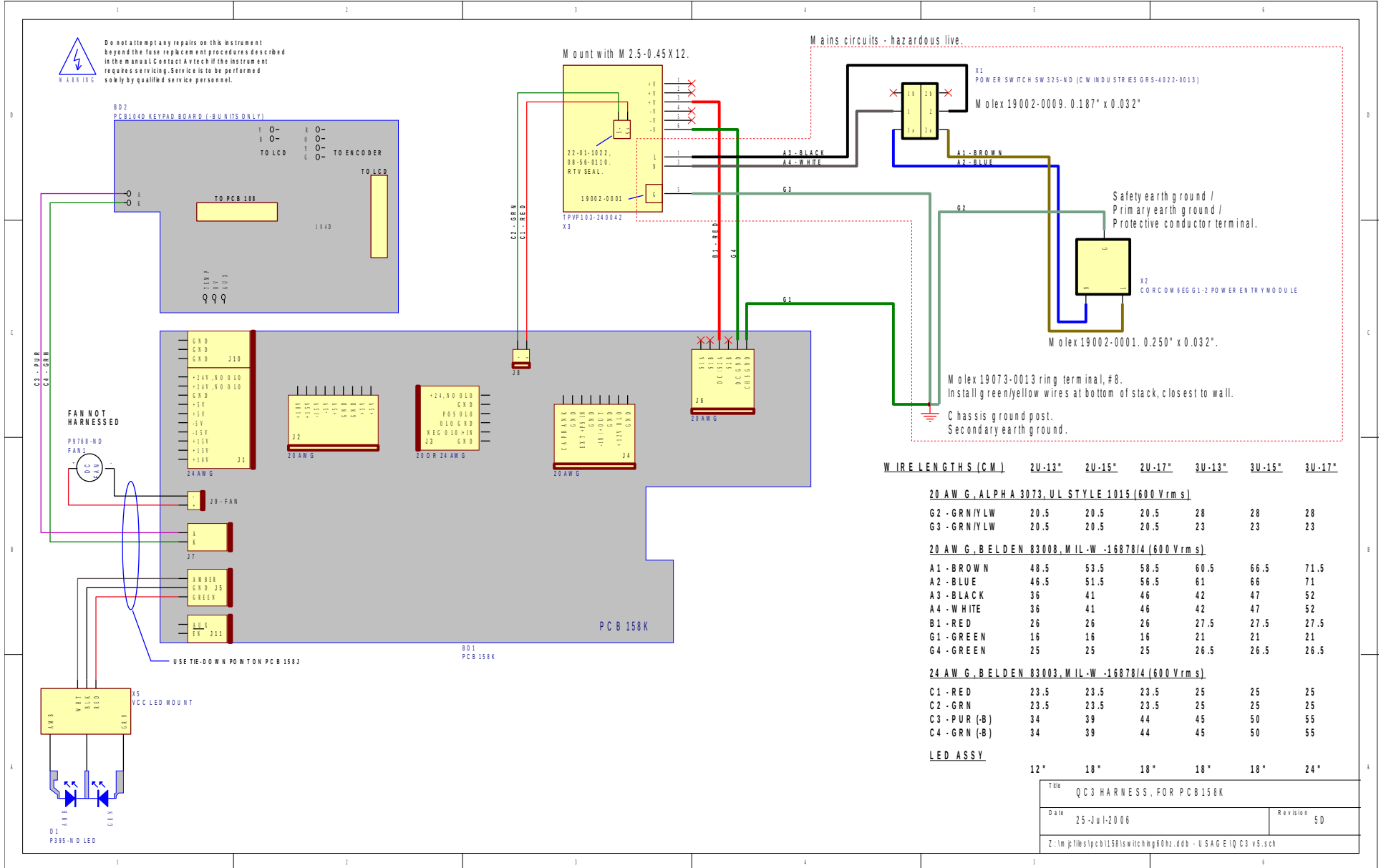

PCB 158K - LOW VOLTAGE POWER SUPPLY, 1/3

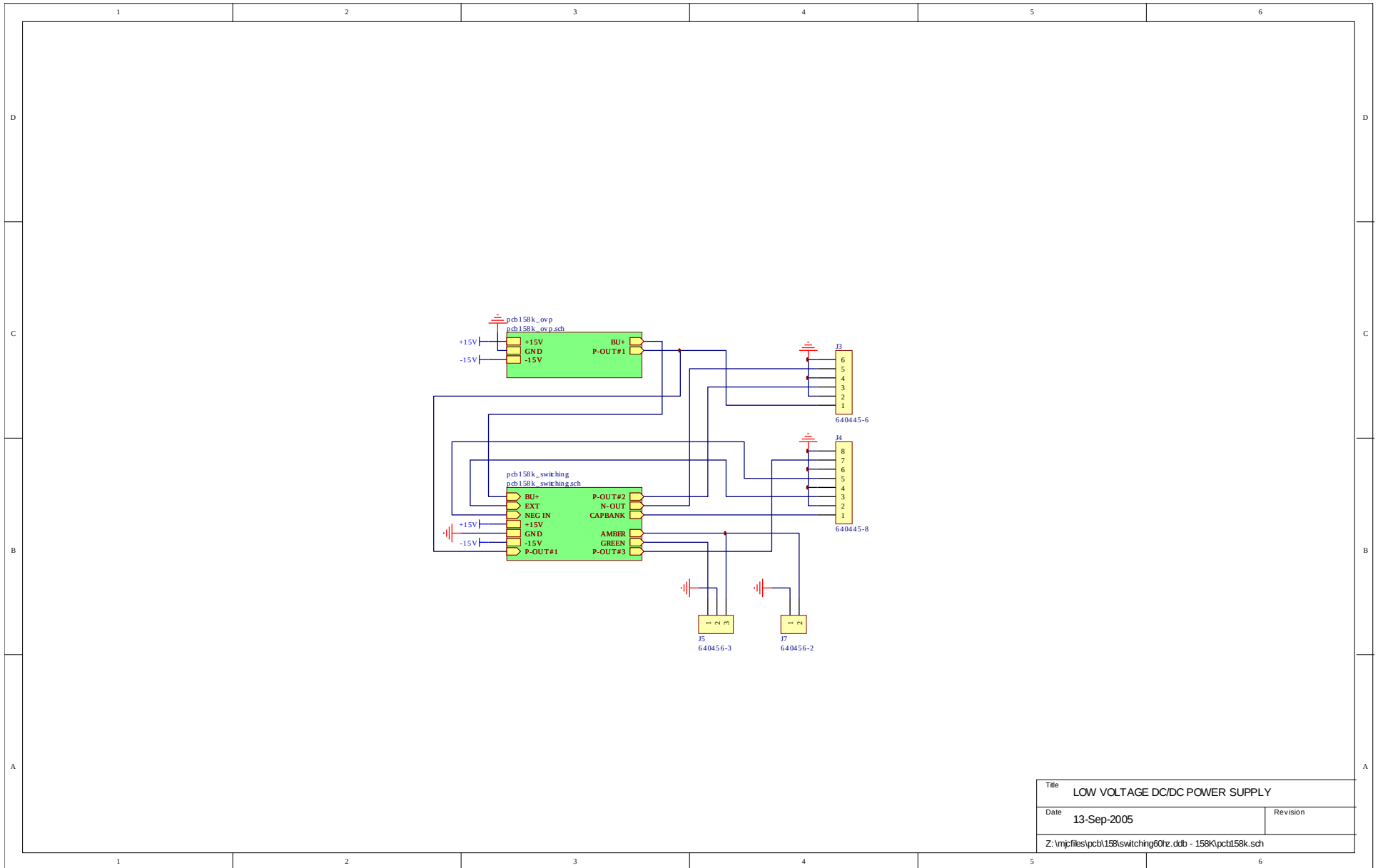

Title		LOW VOLTAGE DC/DC POWER SUPPLY
Date	13-Sep-2005	Revision
Z:\mpjfiles\pcb158\switching01rz.ddb - 158K\pcb158k.sch		

PCB 158K - LOW VOLTAGE POWER SUPPLY, 2/3

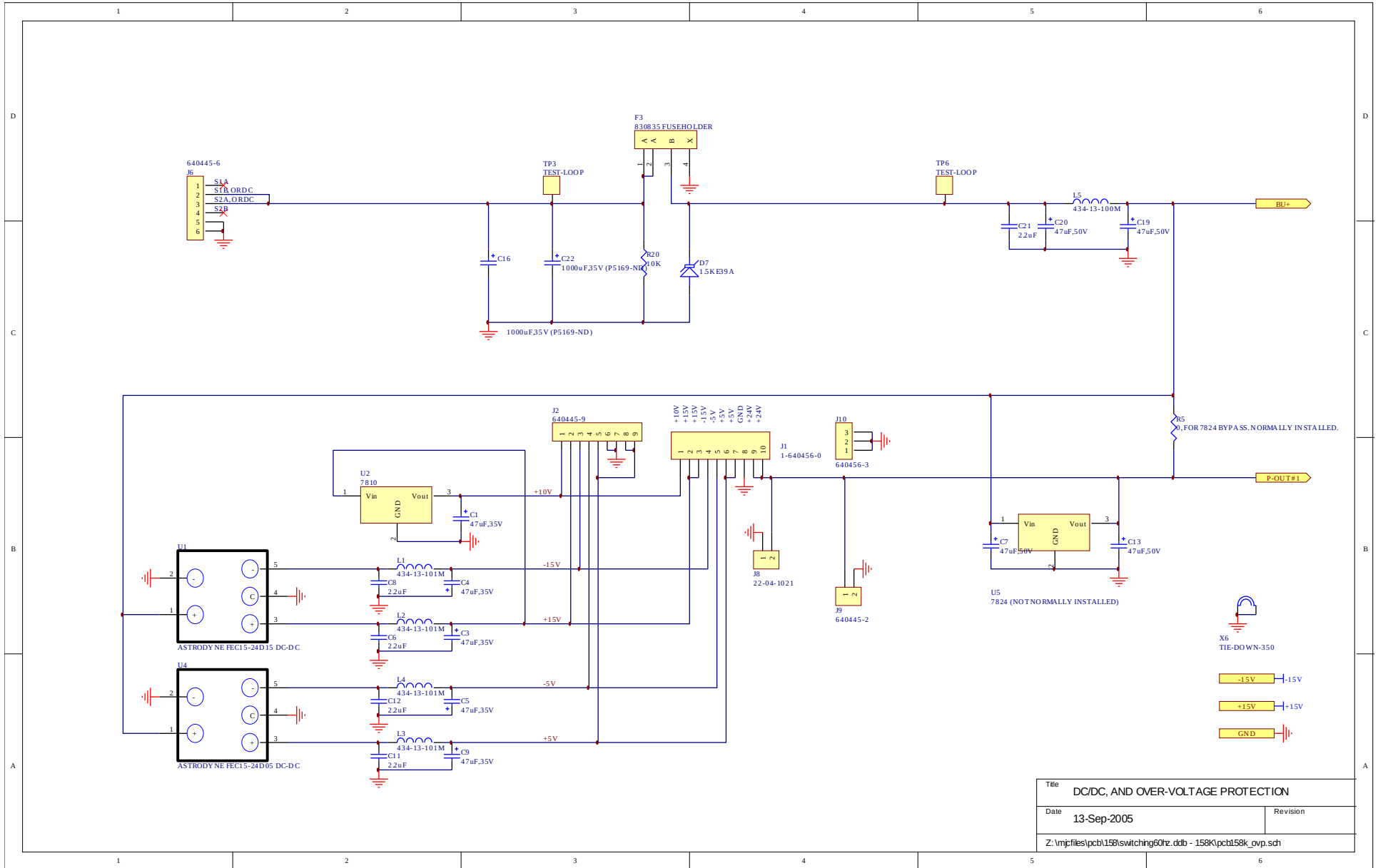

PCB 158K - LOW VOLTAGE POWER SUPPLY, 3/3

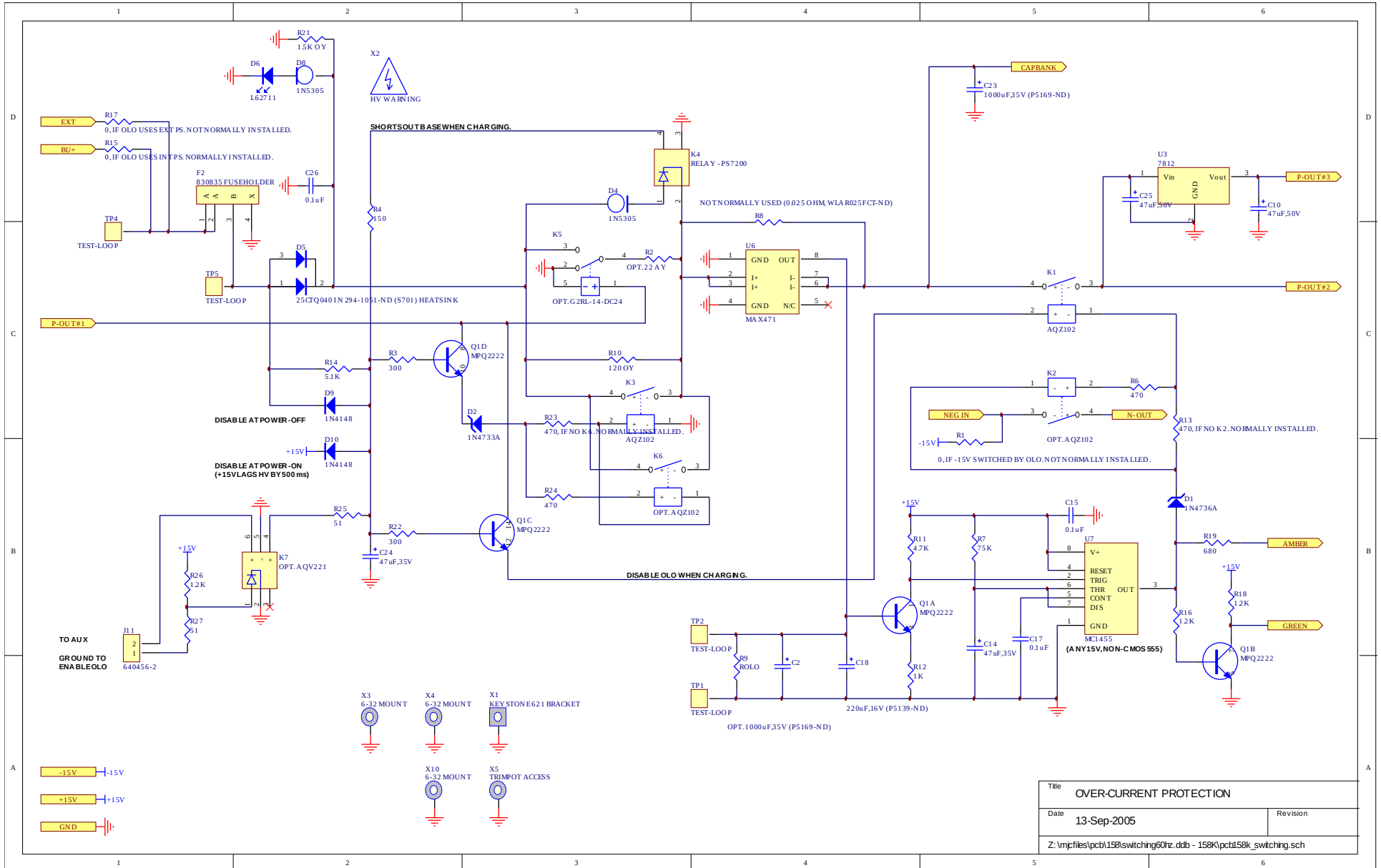

PCB 168B - HIGH VOLTAGE DC POWER SUPPLY

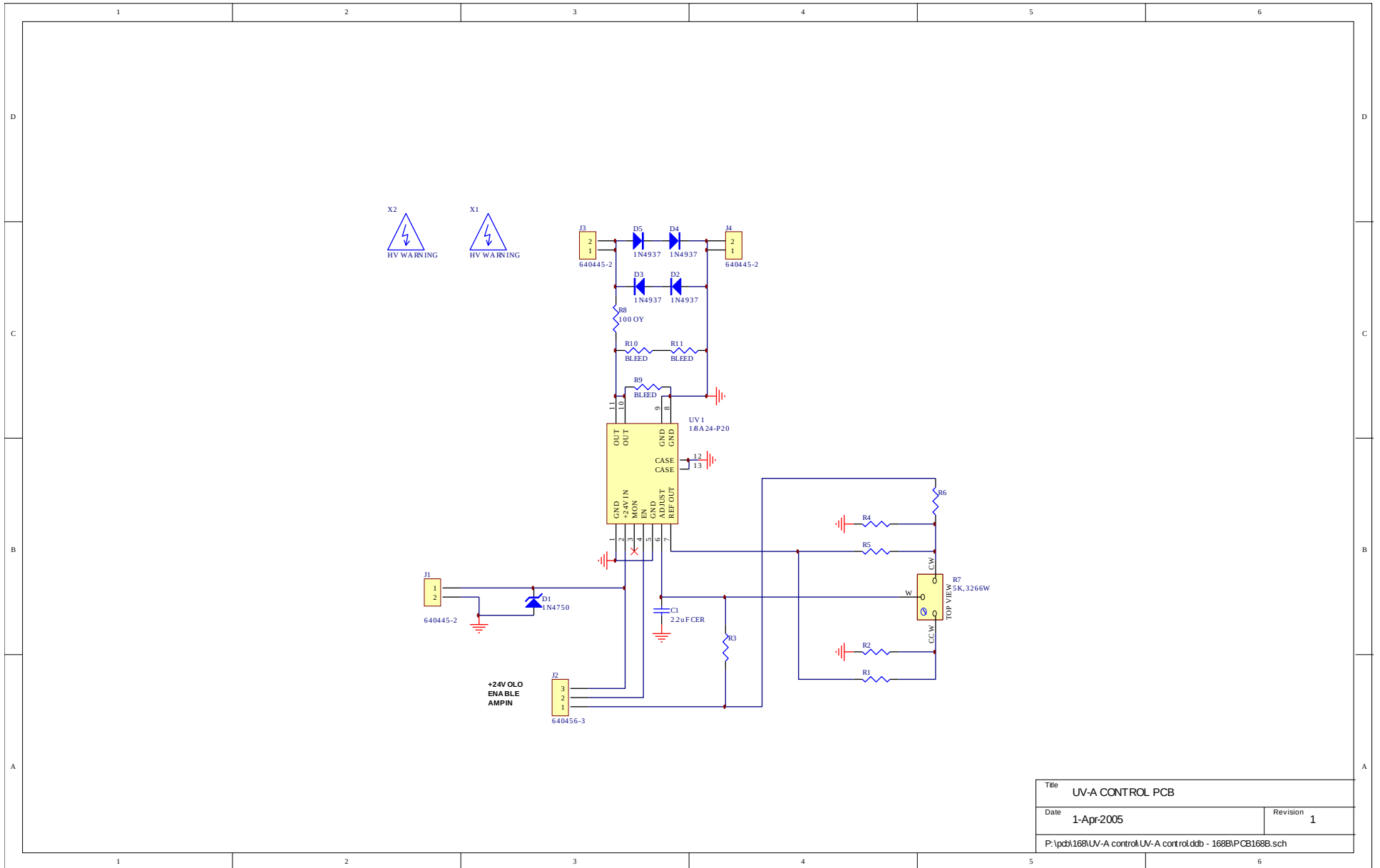

Title UV-A CONTROL PCB	
Date 1-Apr-2005	Revision 1
P:\pcb\168\UV-A control\UV-A control.dtb - 168B\PCB168B.sch	

MAIN WIRING

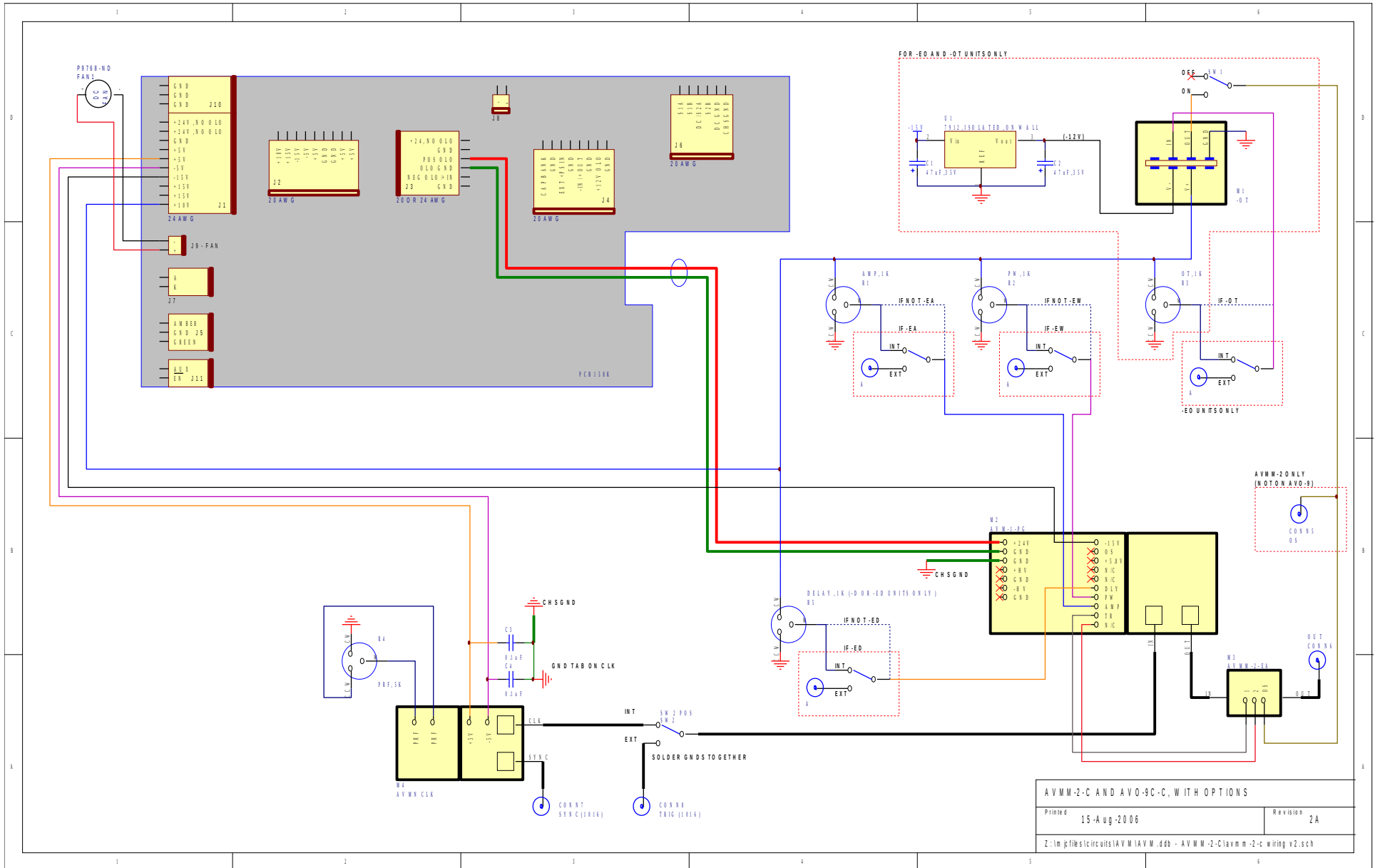

PERFORMANCE CHECKSHEET